

CPV615NR

Produktkategorie	Schublade
Produkthöhe	15 cm
Produkttyp	Vakuumierschublade Sous-Vide
Vitality System	Ja







Design

Farbe	Schwarz	Glasart	Eclipse-Schwarzglas
Oberfläche	Schwarz Hochglanz	Verblendung der Schubladenfront	1 horizontales Profil
Design	Dolce Stil Novo	Markenlogo	Siebdruck
Verzierung der Komponenten	Kupfer	Position des Markenlogos	Intern
Material	Glas		

Bedienelemente

Bedienungsart	Touch Control
---------------	---------------

Programme / Funktionen

Vakuumierung	
Vakuumierung im Behälter	
Chefkoch-Zyklus für	
Welding	

Technische Eigenschaften

					
Schubladenöffnung		Push-Pull (grifflos)			

Schublade auf Teleskop-Vollauszug	Edelstahl	Sicherheitsventil und Öl-Rücksaugschutz für max. Hygiene	Ja
Material der Verschlussabdeckung	Sicherheitsglas mit Rahmen	Trocknung der Vakuumpumpe	Automatisch
Max. Öffnungswinkel der Verschlussabdeckung	65° +/- 3°	Länge der Schweißleiste	260 mm
Schubladen-Stabilisator	Ja	Herausnehmbare Schweißleiste	Ja
Max. Ausladung der Schublade	453 mm +/- 2 mm	Art der Verschweißung	Doppelt
Max. Tragkraft der Schublade	15 kg	Max. Vakuumpierdauer	1'-1'20"
Max. Tragkraft des Gehäuses	48 kg	Max. Vakuumpierleistung	2-10 mbar (99,9%)
Nutzbares Schubladenvolumen	6,5 l	Vakuumpier-Sensor	Ja, Genauigkeit 10 mbar
Pumpenleistung	4 m ³ /h	Serienzubehör	Vakuumpierbeutel für Konservierung, Vakuumpierbeutel für Sous-Vide-Cooking

Elektrischer Anschluss

Netzstecker	(F;E) Schuko	Spannung	220-240 V
Elektrischer Gesamtanschlusswert	240 W	Frequenz	50-60 Hz
Absicherung	1 A		

Logistik-Informationen

Produktbreite	597 mm	Produktlänge	595 mm
Produkttiefe	570 mm	Produktbreite	560 mm
		Produktlänge	135 mm

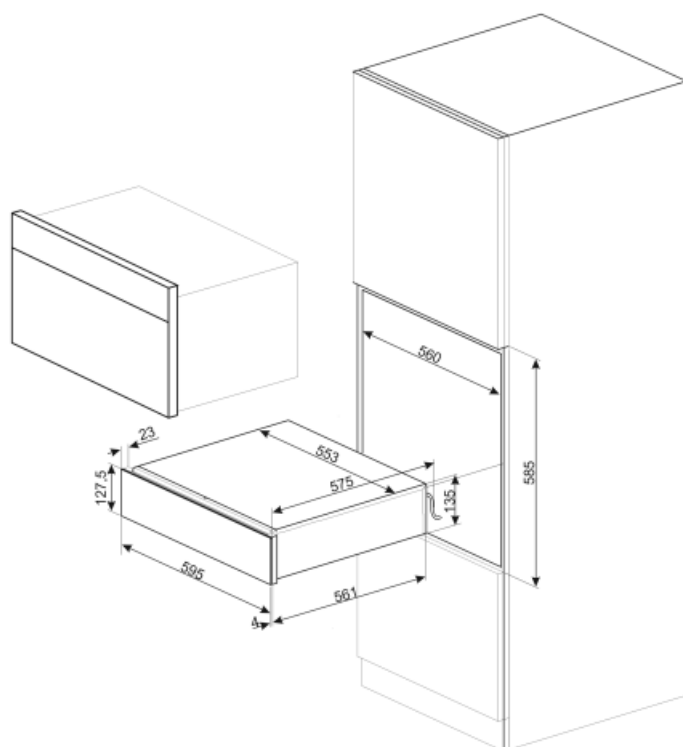

Not included accessories

VBAG1



Vakuumierbeutel 20 x 30 cm für Sous-Vide-Garen, Konservierung und Einlagerung, Verpackungseinheit 50 St., kompatibel für: EinbauVakuumierschubladen. Lagerung für Speisekammer, Kühlschrank, Gefrierschrank und Sous-Vide-Garen im Dampfbackofen. Temperaturbeständig von -40°C bis +120°C.

VBAG2

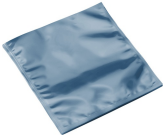











Vakuumierbeutel 25 x 35 cm für Sous-Vide-Garen, Konservierung und Einlagerung, Verpackungseinheit 50 St., kompatibel für: EinbauVakuumierschubladen. Lagerung für Speisekammer, Kühlschrank, Gefrierschrank und Sous-Vide-Garen im Dampfbackofen. Temperaturbeständig von -40°C bis +120°C.

LIFEBOX



3 Vakuumierbehälter H: 125, 170, 185 mm, Ø 140 mm für Konservierung u. Einlagerung von druckempfindlichen Lebensmitteln, kompatibel für Einbau-Vakuumierschubladen. Lagerung für Speisekammer oder Kühlschrank. Nicht spülmaschinenfest.

Symbols glossary (TT)

- | | | | |
|---|---|--|--|
|  | The Chef function alternates compression and decompression cycles and speeds up some operations, such as marinade or infusion, that otherwise would require a lot of time. |  | Preservation vacuum bags. These bags endure temperatures from -25°C to 70°C (for 2 hours) or 100°C (for 15 minutes). Suitable for pantry, refrigerator and freezer storage, they cannot be used for vacuum cooking. |
|  | The vacuum in bag function guarantees to create vacuum into bags choosing among three levels. It is also possible to set the 0 level to seal the bag without creating the vacuum. |  | The stabilization device maintains the drawer open when used, avoiding closing it accidentally. |
|  | Sous-vide cooking bags. These bags endure a maximum temperature of 85°C (for 75 hours), 100°C (for 4 hours) or 121°C (for 30 minutes). Suitable for pantry and refrigerator storage, they cannot be storage in the freezer. |  | The vacuum in container function guarantees to create vacuum into glass or plastic containers choosing among three different levels. Use only certificate containers suitable for vacuum and able to resist to a 99,9% vacuum. |
|  | Setting the highest vacuum in bag/container level, it is reached a 99,9% vacuum. |  | VAKUUM-SENSOR |
|  | The machine can be set at three different sealing levels. Setting the maximum level is possible to seal more bags at the same time with a unique cycle. |  | The machine carries out a double phase welding which guarantees to seal dirty and oily bags as well. |