

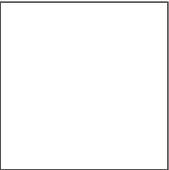

D U N E



Booklet available in English on
Heft in deutscher Sprache erhältlich auf
Livret disponible en français sur
Libretto disponibile in italiano su
Folleto en español disponible en
如需中文版手册, 请访问





LEGO.com/sustainable-packaging



FR
**DONNEZ
OU
RECYCLEZ**



ASSOCIATION

OU



MAGASIN

OU



DÉCHÈTERIE

Adresses sur quefairedemesdechets.fr



BUILDER



Apple and the Apple logo are trademarks of Apple Inc., registered in the U.S. and other countries and regions. App Store is a service mark of Apple Inc. Google Play and the Google Play logo are trademarks of Google LLC. Tencent and the Tencent logo are trademarks of Tencent Inc.

LEGO.com/devicecheck



LEGO® Builder

CULTIVATING DESERT POWER

🏠 *Dune* and *Dune: Part Two* have captivated long-term and new fans of the immersive universe created by Frank Herbert in his 1965 novel. Set in the year 10191, on the brink of an interstellar conflict, the story chronicles young Paul Atreides' rise to the calling of his noble heritage. By order of the omnipotent Emperor, Paul is thrust into unfamiliar territory on planet Arrakis, also known as Dune, which is inhabited by powerful desert warriors, the Fremen, and the only known planet to produce the precious spice. As the treacherous Baron Harkonnen turns against the Atreides family, Paul uncovers the deepest secrets of the planet, its people and his own destiny.

Riddled with gargantuan sandworms known to the Fremen as Shai-Hulud, the inhospitable desert world is perilous to travel by land. Flying vehicles are vital to survival. The ornithopter is built to withstand Arrakis' scorching heat, sandstorms and winds of more than 800 km/h (497 mph). It plays a pivotal role in several key sequences, starting with the Atreides family's arrival at the capital city of Arrakeen and Duke Leto's inspection of a spice-harvesting operation, where Paul first experiences the open desert. Reminiscent of a dragonfly, with no computer systems, the ornithopter's eight wings can fold up against its body while grounded or during quick dives, and flap rapidly when extended. The vehicle's landing legs retract to optimise its aerodynamic properties.



MEET THE MINIFIGURE CHARACTERS



PAUL ATREIDES

The son of a Duke, born into a destiny greater than his royal title, young Paul is thrust into an epic adventure of discovery that will take him across the galaxy to a barren and inhospitable world with danger around every corner. Paul must rise to conquer his fears as the fate of the galaxy rests on his young and untested shoulders.



DR. LIET-KYNES

Imperial Planetologist and Judge of the Change, assigned by the Emperor to oversee the smooth transition of power on Arrakis. An expert on the planet and the ways of its people, her connection to Dune goes beyond mere duty – she has forged a bond with the land and its inhabitants that has made her more Fremen than Imperial.



DUKE LETO ATREIDES

Duke Leto is a man guided by two watchwords: honour and duty. The noble and beloved head of House Atreides, he must lead his people in an exodus to a new world and protect his son, Paul, as malevolent forces gather, threatening to permanently erase the Atreides name from the pages of history.



LADY JESSICA

A mother and leader bonded unbreakably with her son – a royal heir with a far-greater destiny. In motherhood, what began as an act of duty became an act of love. Skilled at influencing others by wielding the mysterious powers of her Bene Gesserit voice and mind, she must prepare Paul to one day lead an army as the last light of hope to save a universe from falling into darkness.



GURNEY HALLECK

Trusted advisor of Duke Leto and Warmaster of House Atreides, Gurney Halleck is an irreverent and quick-witted artist with a sword, and is equally skilled at wielding a song with his chosen instrument, the baliset. Gurney will do whatever it takes to protect the Duke and his family — people as dear to him as the family he lost to the Harkonnens.



CHANI

A powerful Fremen warrior, Chani is a mysterious vision with haunting blue eyes who visits Paul's dreams, calling him to an unknown destiny beyond the far reaches of the galaxy. When she is revealed to be more than just a dream, Paul is haunted by a new mystery: how can two people who have never met know each other so intimately?



DUNCAN IDAHO

Known as the 'killer extraordinary', Duncan is a tactical combat expert and confidant loyal to House Atreides. The most gifted Swordmaster in the Known Universe, he is always watching the horizon in a world of unknown dangers. Forging a bond with young Paul and Duke Leto, Duncan is the first Atreides soldier sent by the Duke to scout out the forbidding planet of Dune.



BARON VLADIMIR HARKONNEN

A Machiavellian force of malevolence, determined to feed his addiction to brutality. A gravity-defying monster of a man, gliding through the air like a phantom of cruelty, the figurehead of House Harkonnen rules through fear, determined to take back the throne and reclaim the spice-rich sands of Dune from House Atreides. While this black-blooded tyrant breathes, no one is safe.

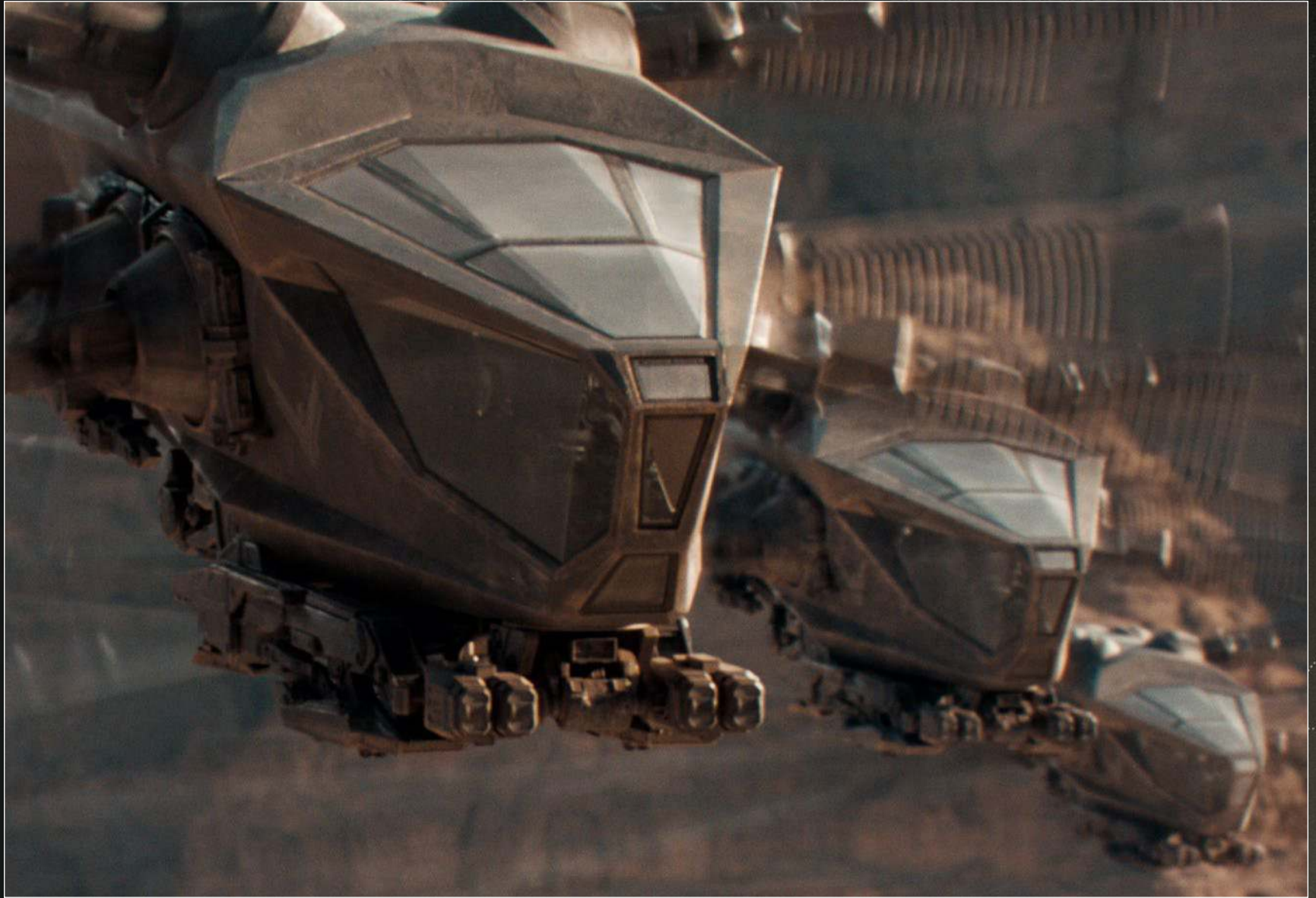

FROM THE LEGO® DESIGN TEAM

📍 "This LEGO® model is a minifigure-scale recreation of the House Atreides Royal Ornithopter from *Dune*. That design stayed very true to the description in Frank Herbert's novel and we thought it would be exciting to recreate it in a LEGO version. We received a cornucopia of reference material from Legendary and the film's award-winning production designer, Patrice Vermette, that showed details of how all the functions worked and how the model should look. The film version was built on set by Patrice and his team, including full-scale models with wings. It was our job to make them 'real'. And, of course, we had to include the wings' flapping and folding mechanisms. Those were some of the trickiest functions, in part because of how they needed to fit and unfold in so many ways around the model. For the landing legs' extend/retract function, we used specialised LEGO Technic elements to get them working exactly how we wanted. They are all linked and need to fit inside the tight spaces in the body of the vehicle. We hope you enjoy building (and flying) your own ornithopter!"

*Mike Psiaki,
LEGO® Icons Design Master*

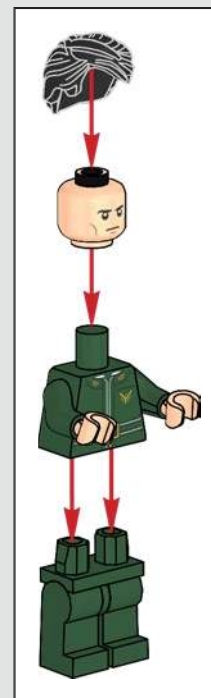
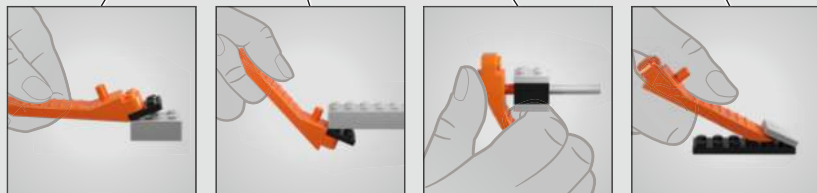
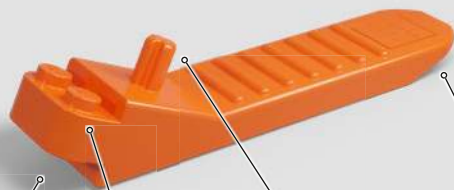

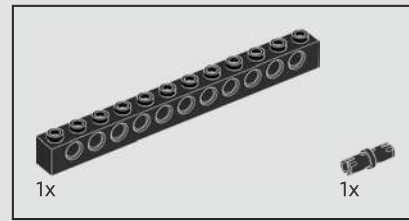
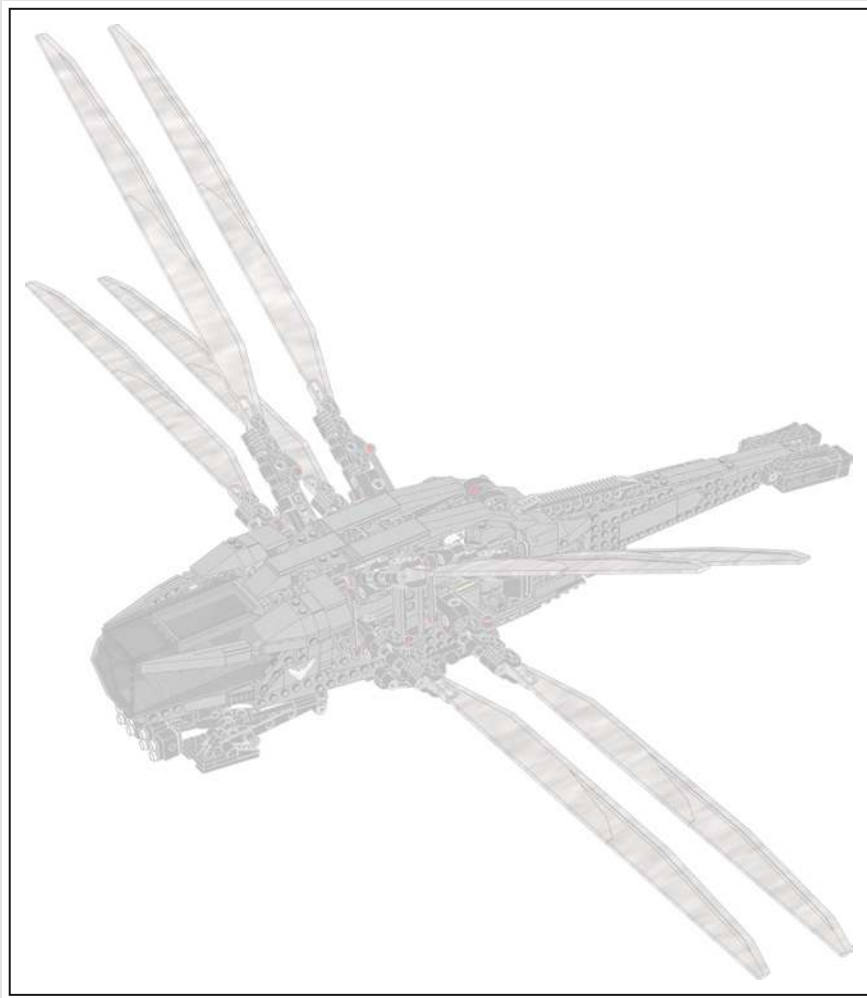

1

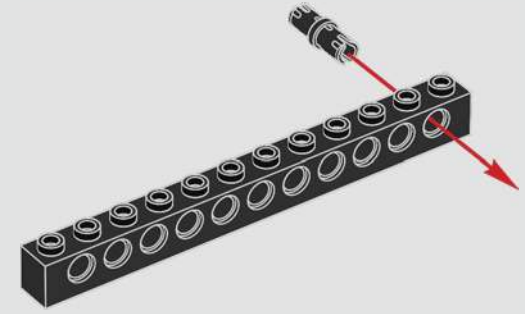

2

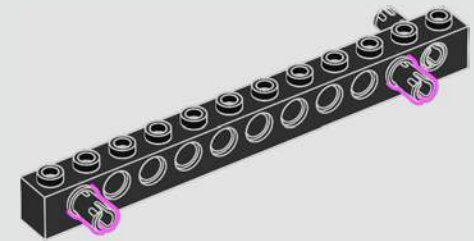

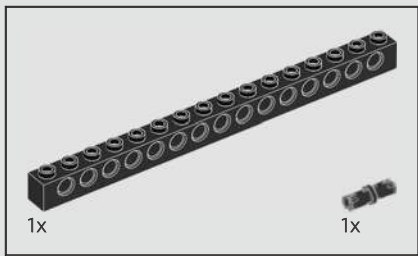

3

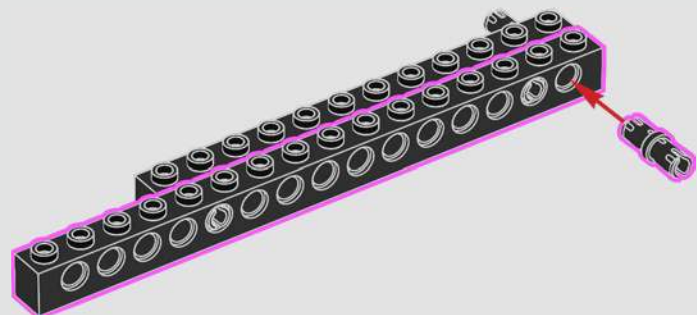

4

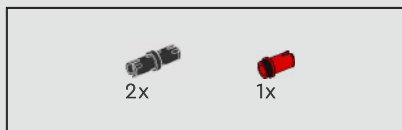
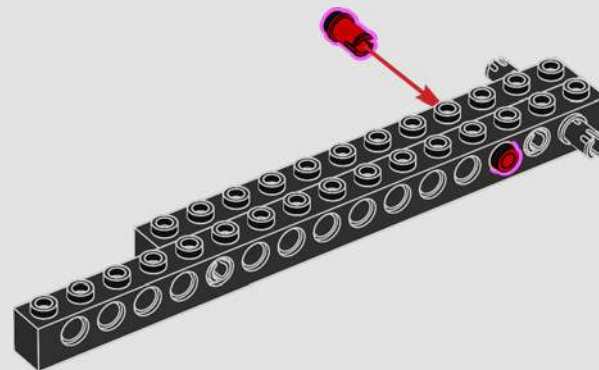

5

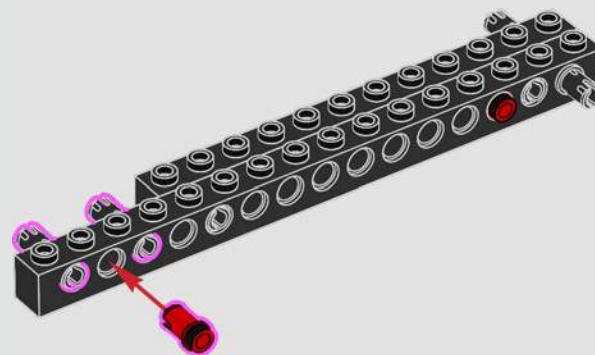

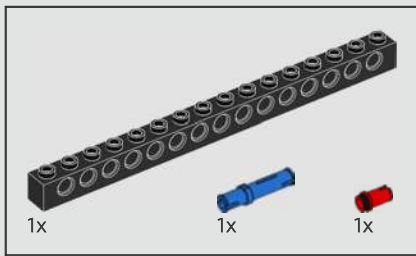

6

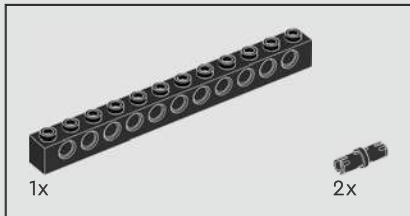
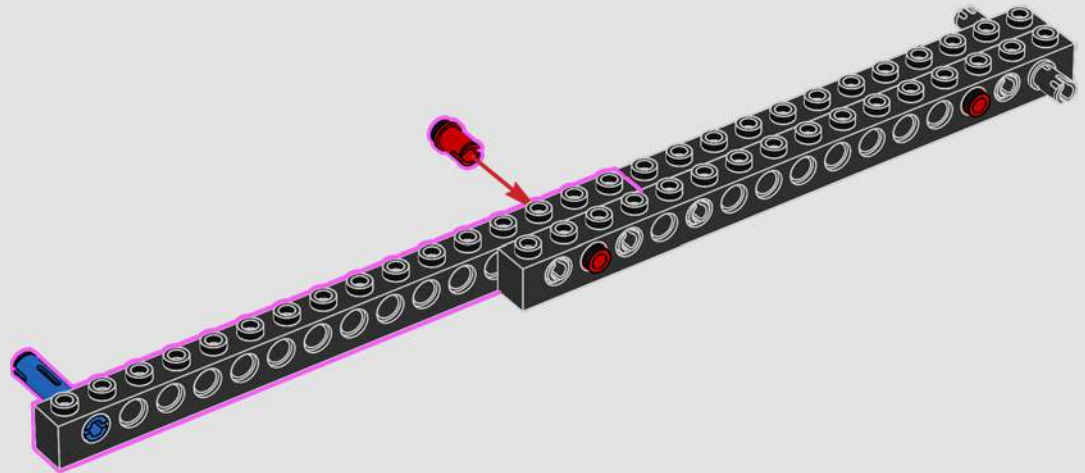

7

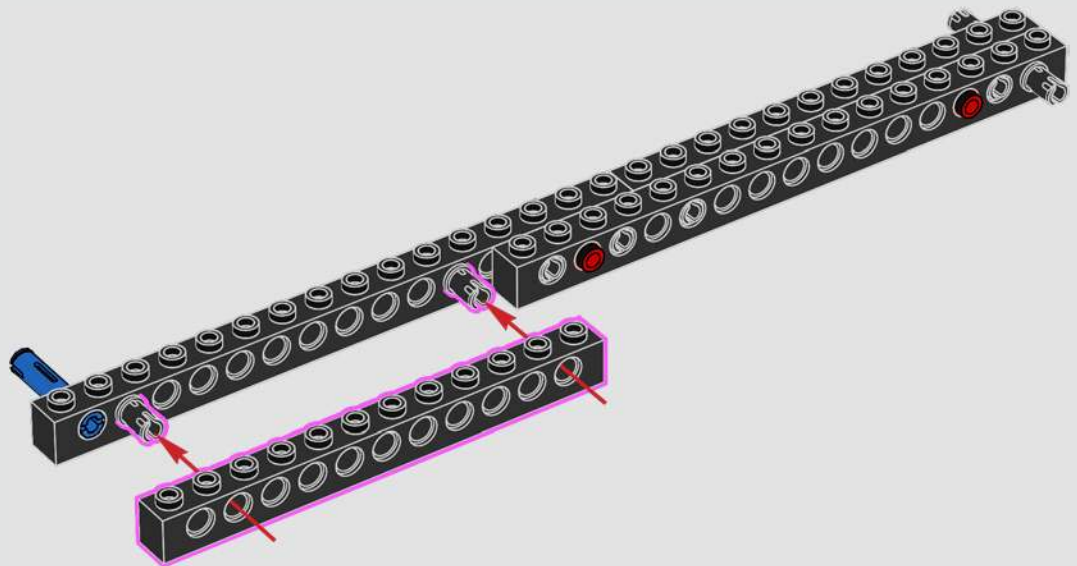

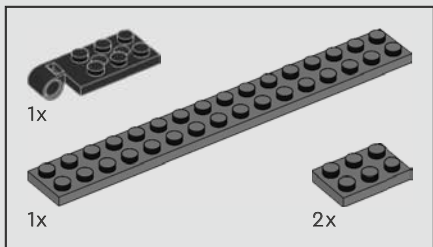

8

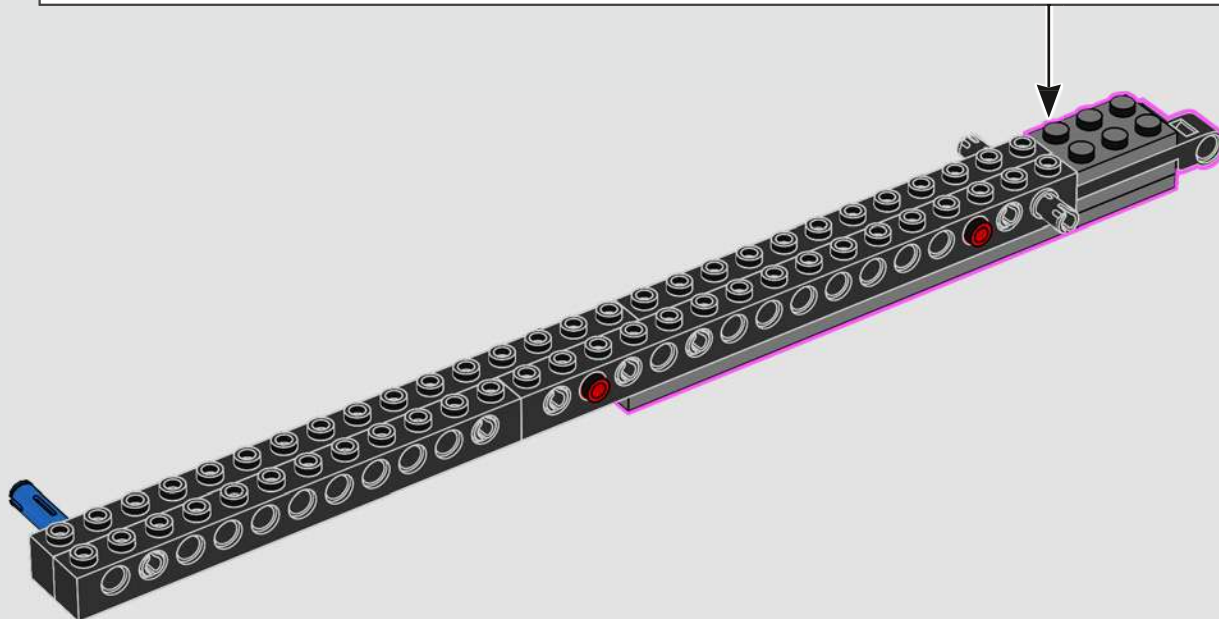
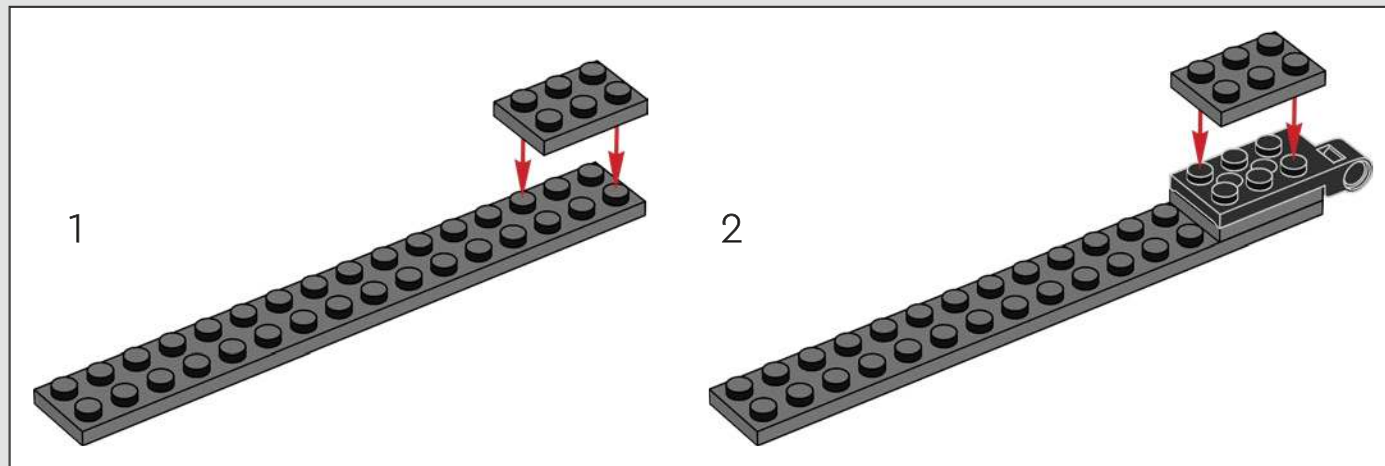

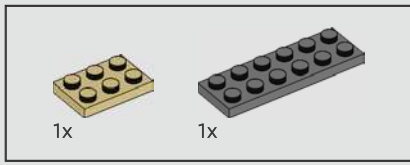

9

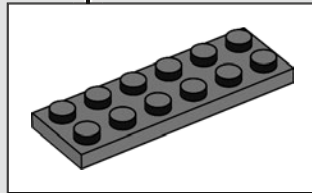
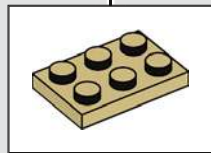
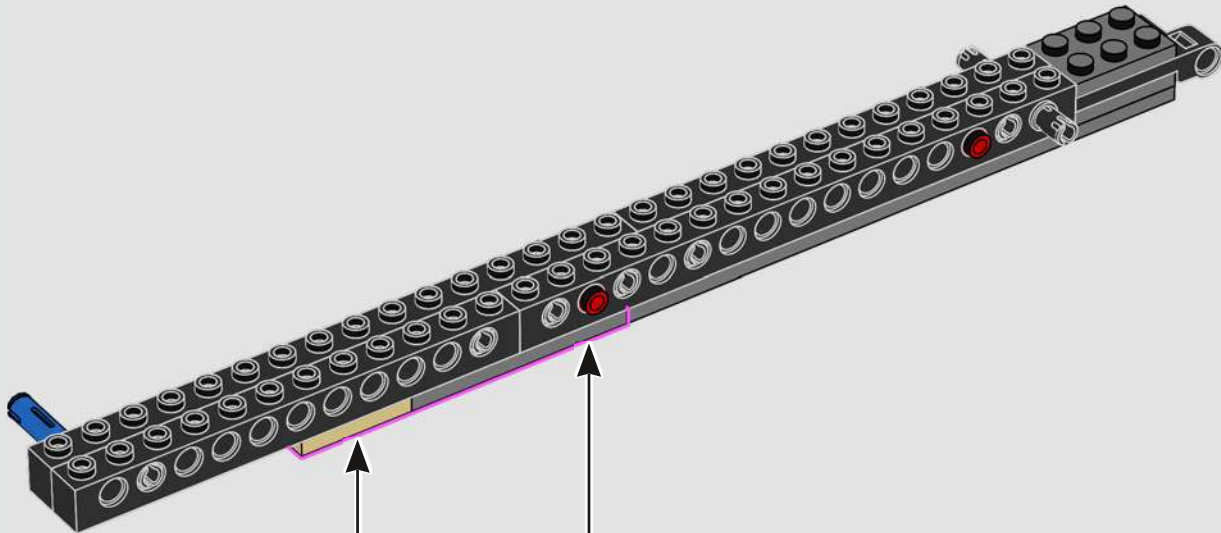

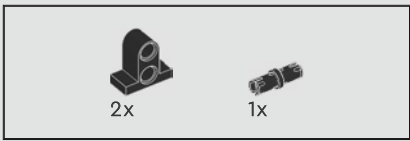

10

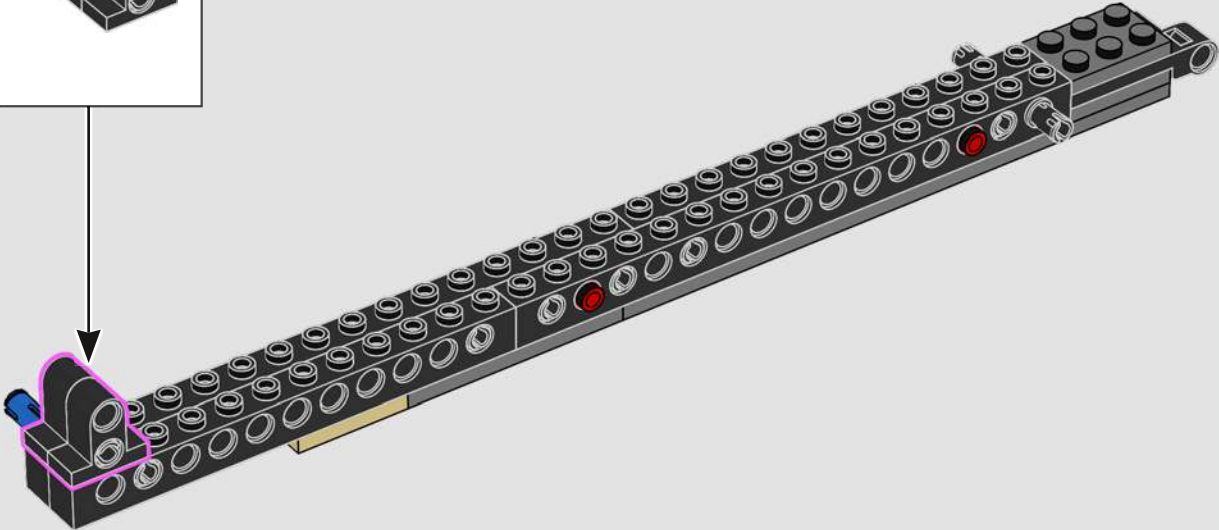
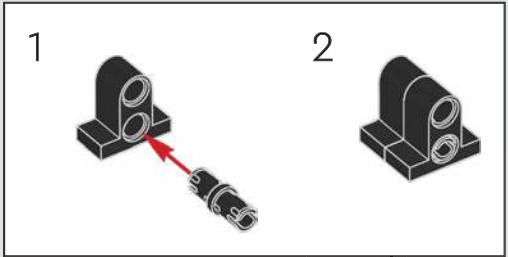

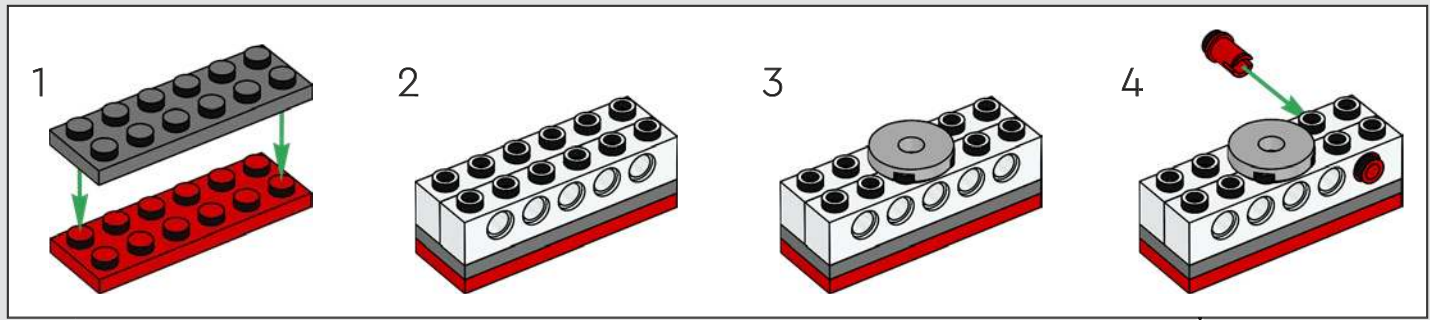
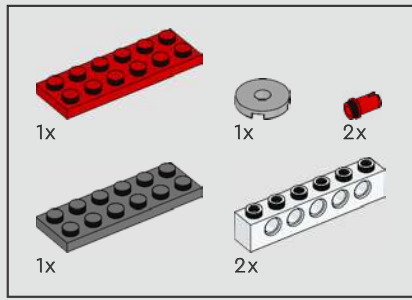

11

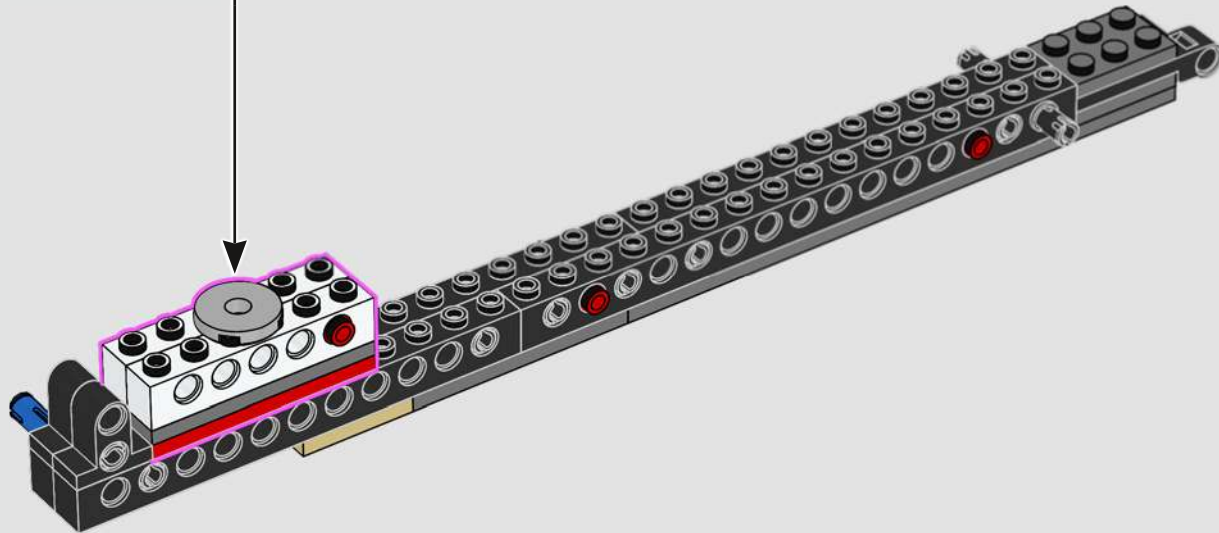

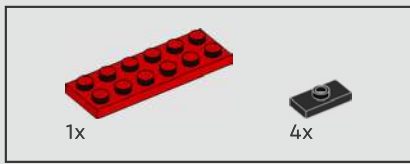

12

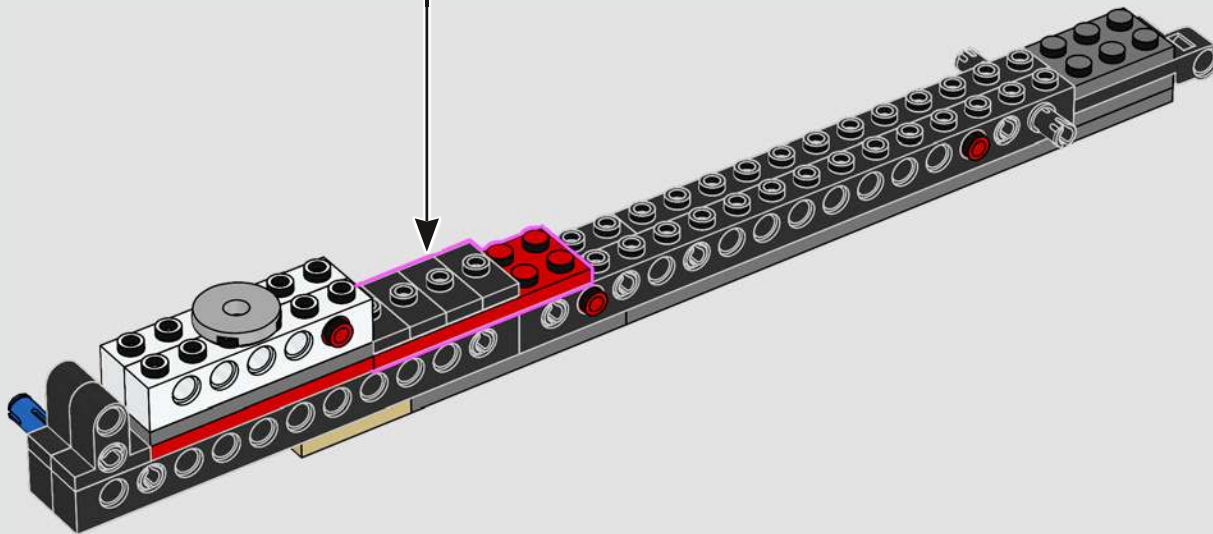
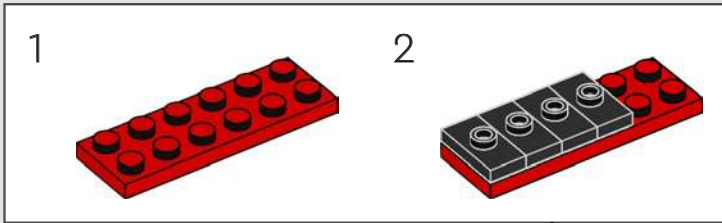

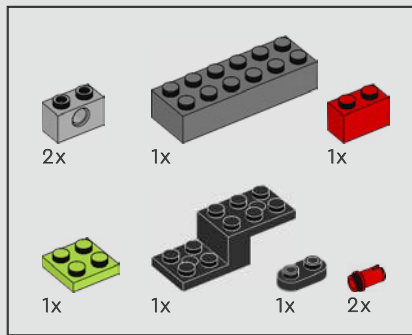

13

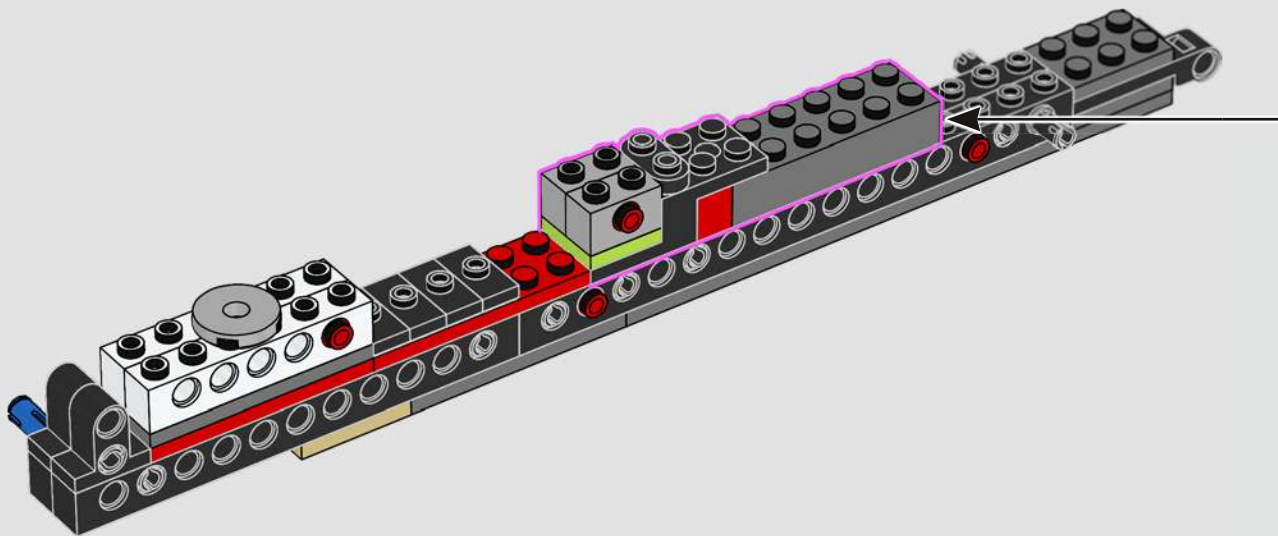
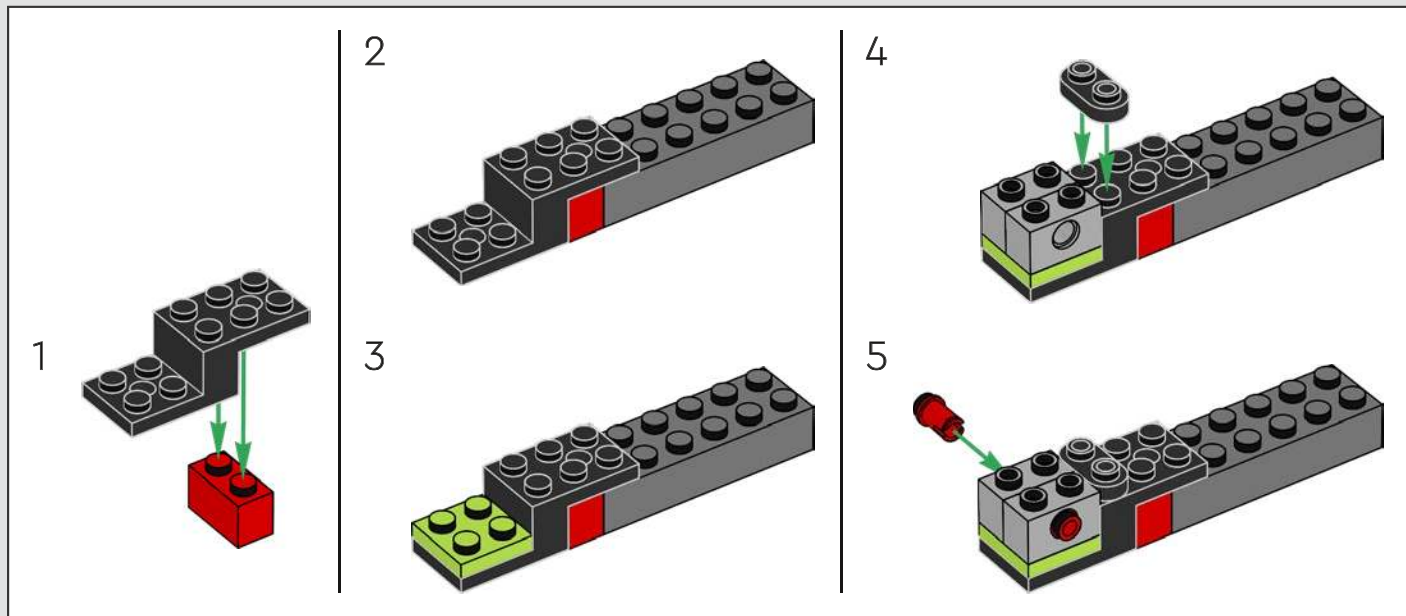

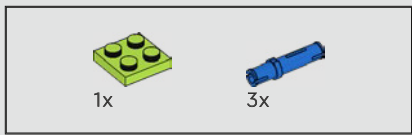

14

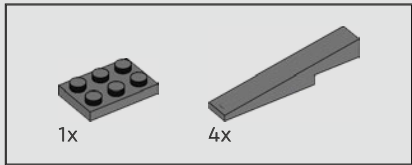
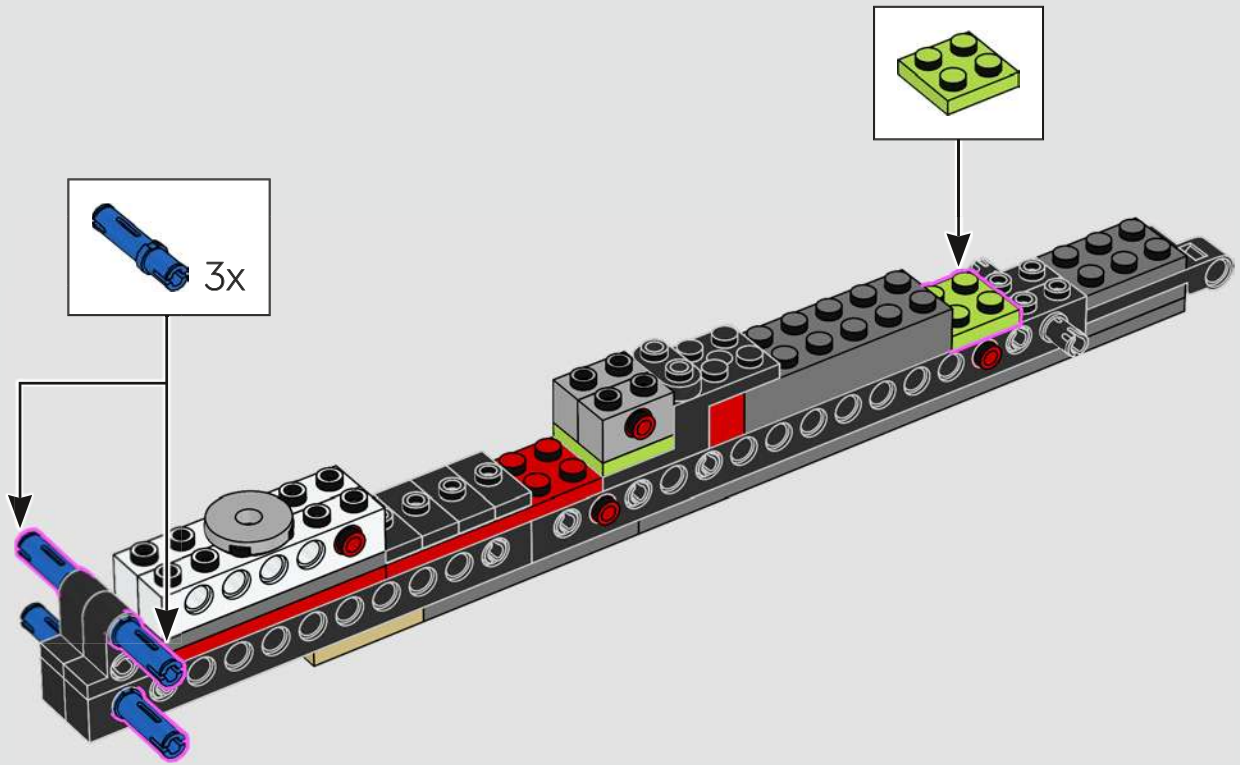

15

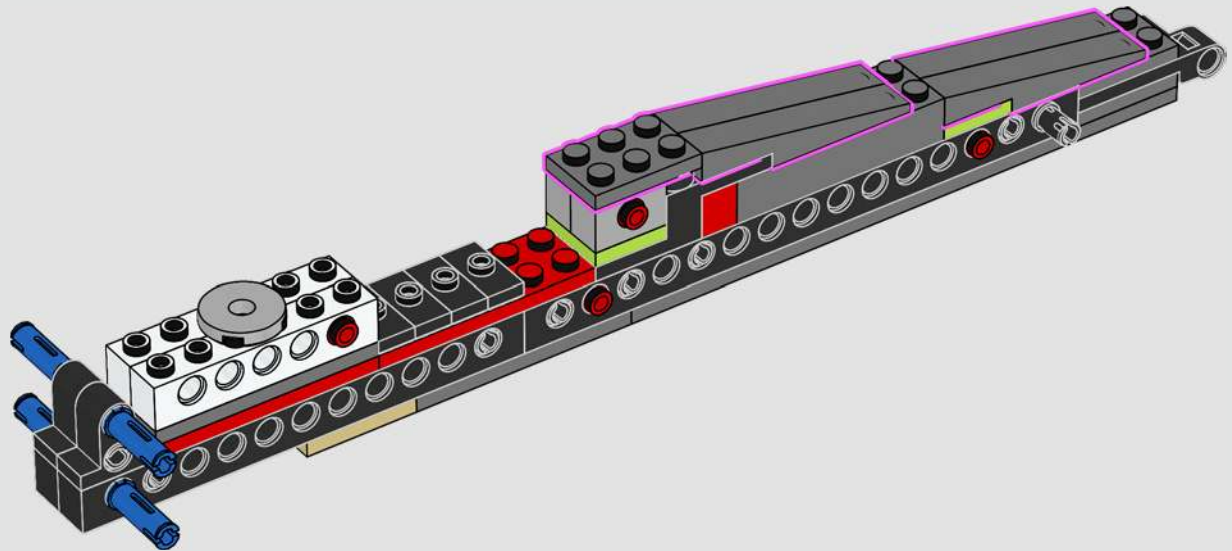

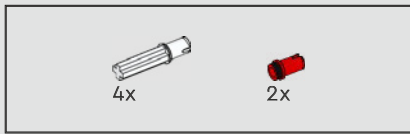

16

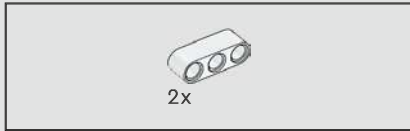
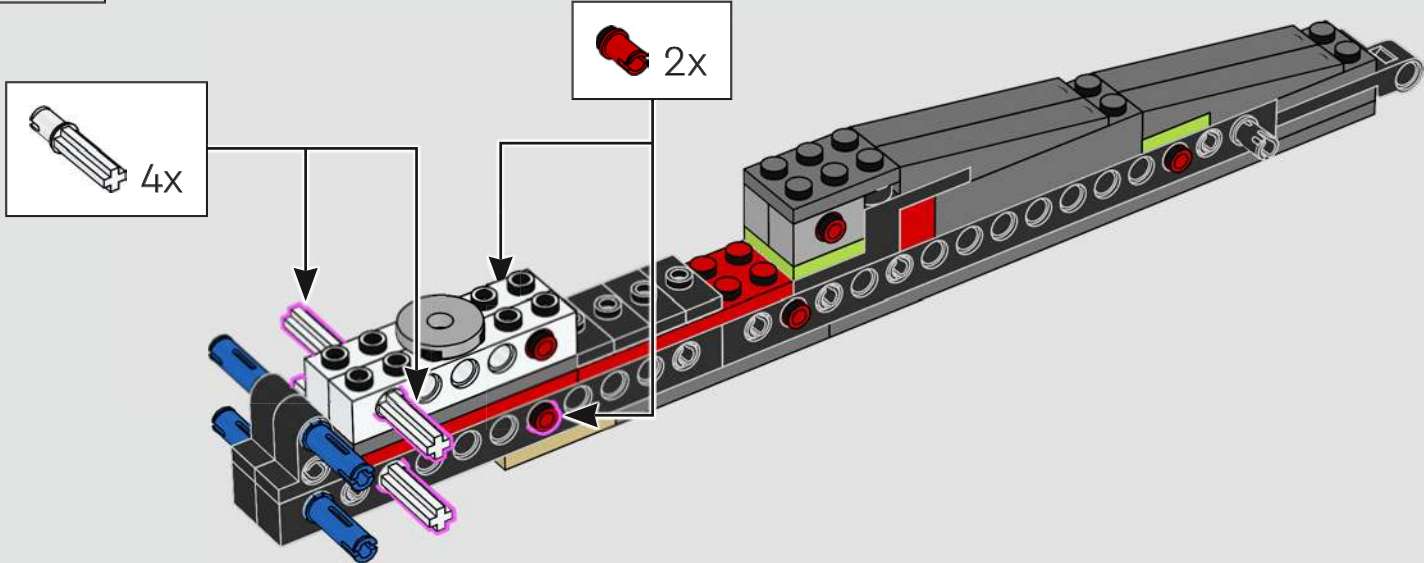

17

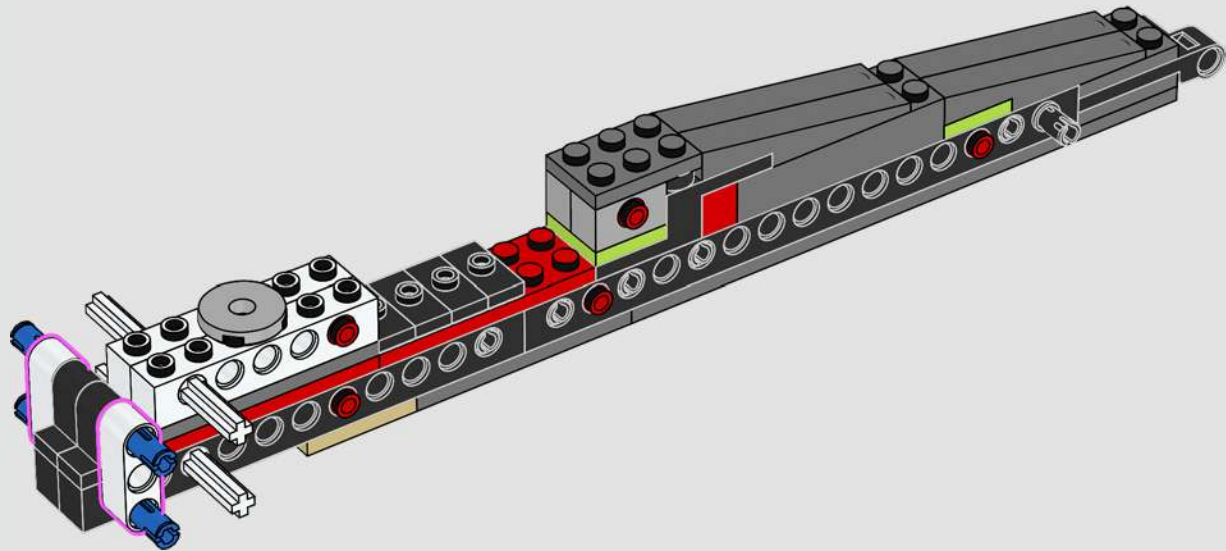

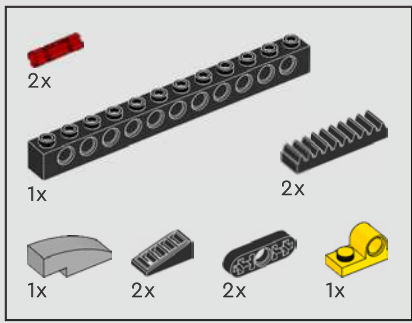

18

1

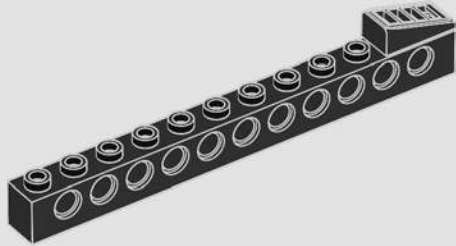

2

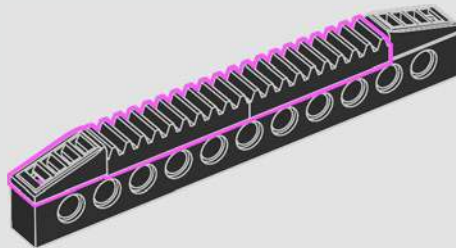

3

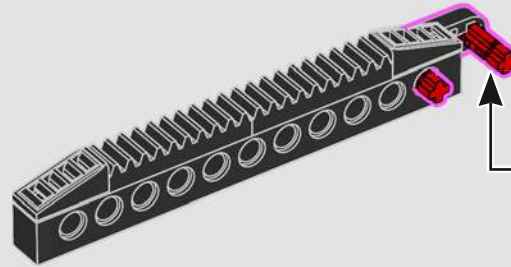

1



2



4

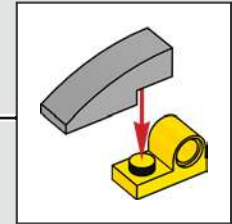
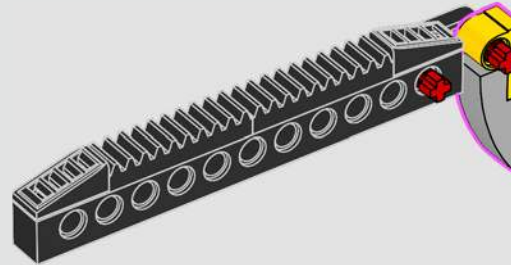

5

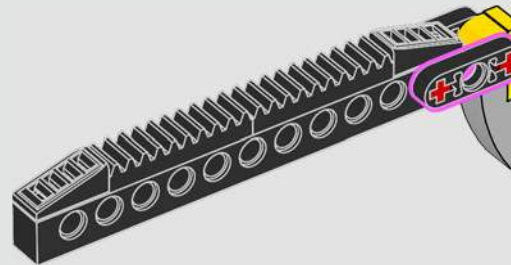

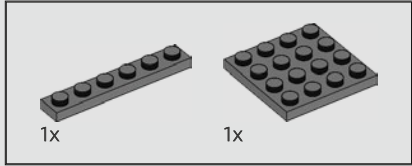
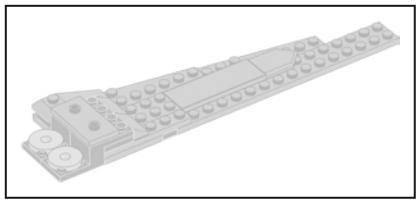

19

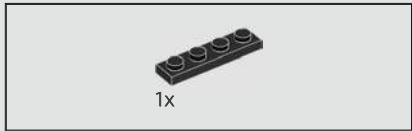
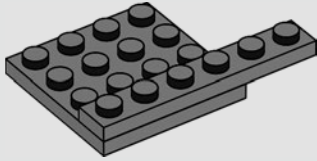

20

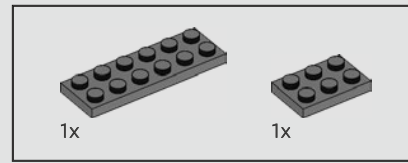
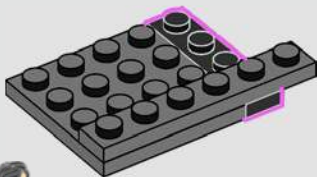

21

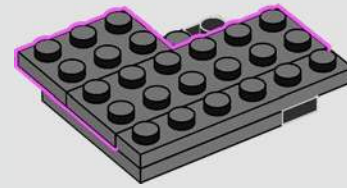

22

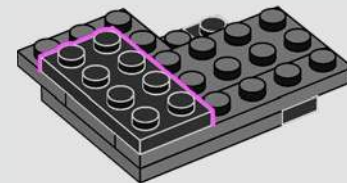

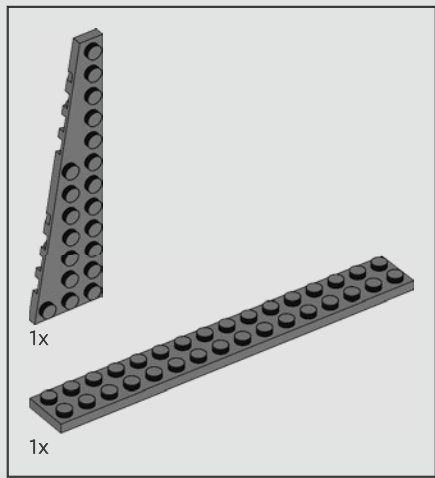

23

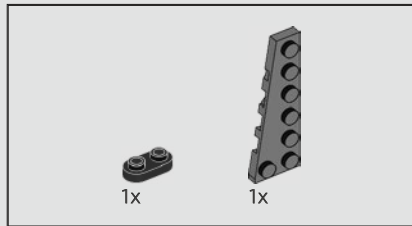
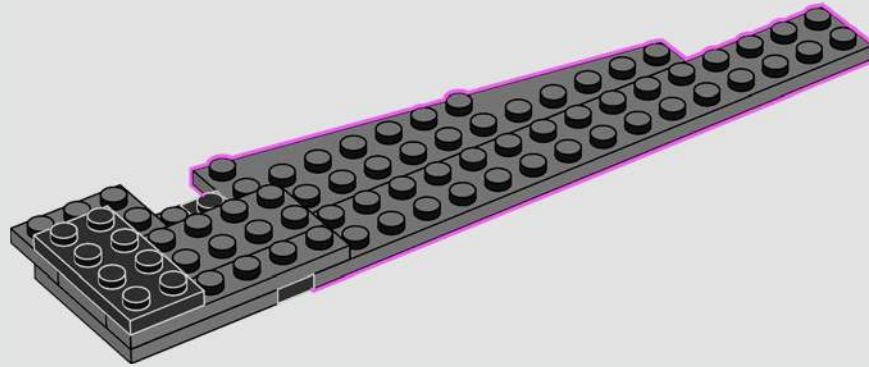

24

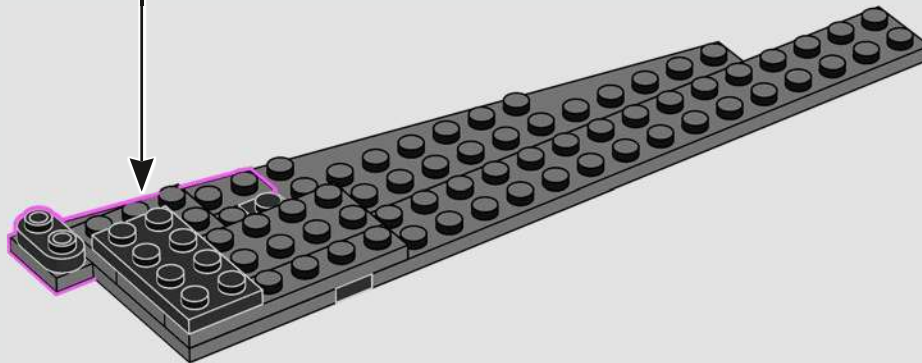
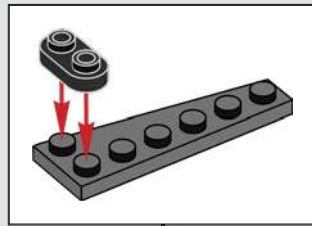

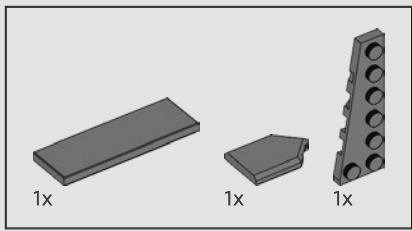

25

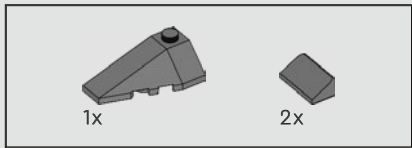
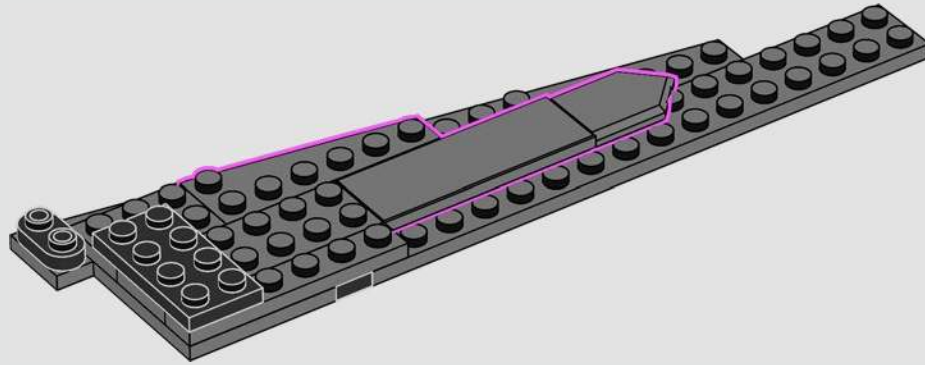

26

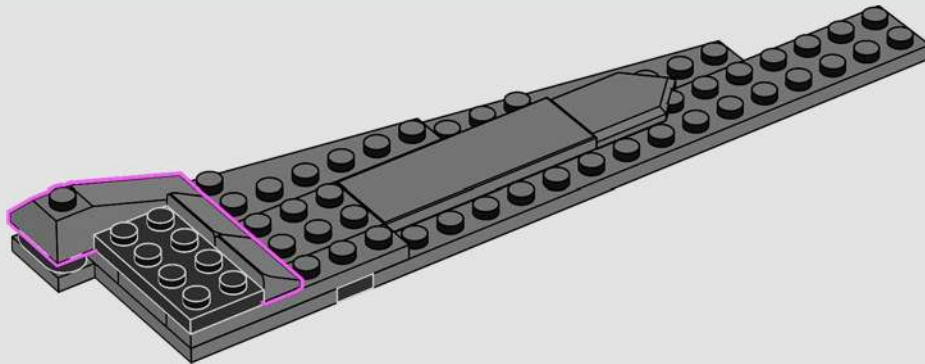

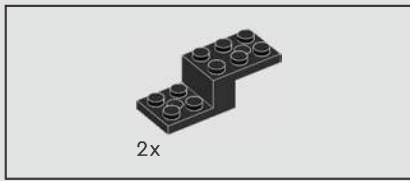

27

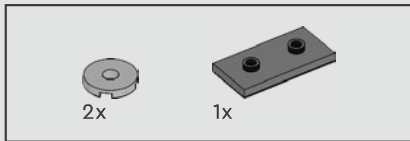
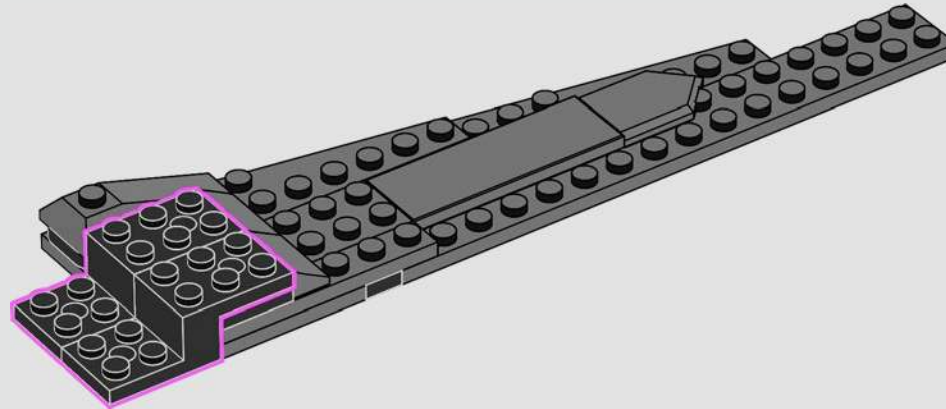

28

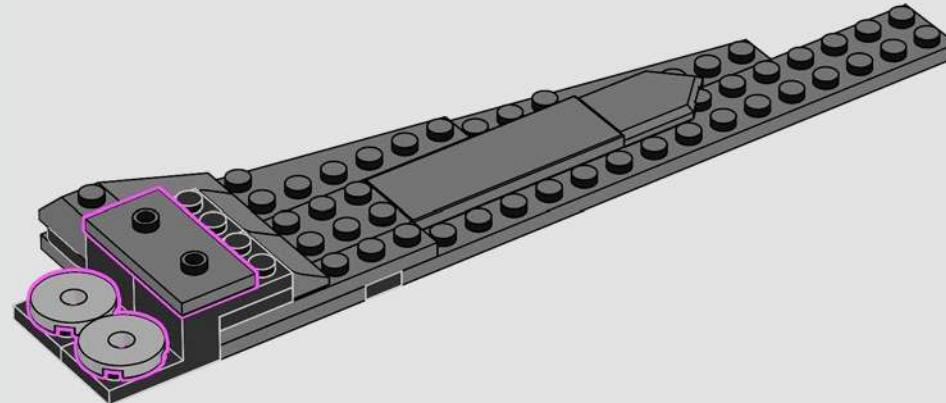

29

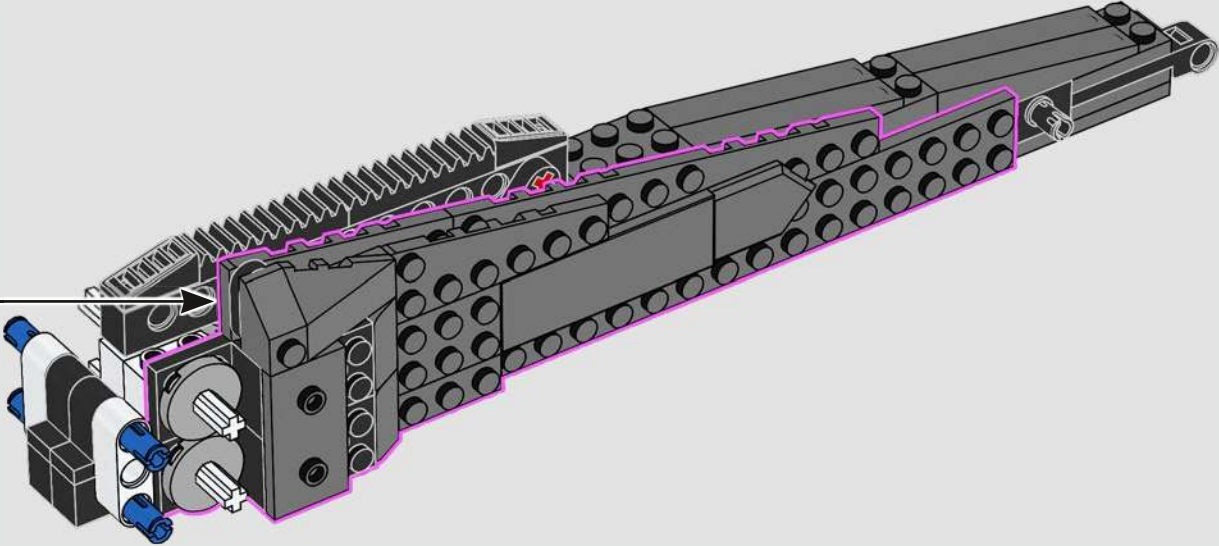

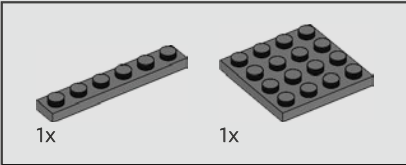
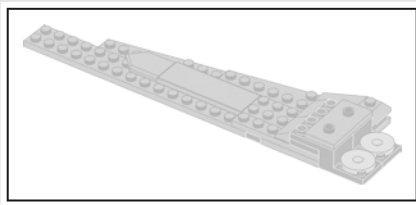

30

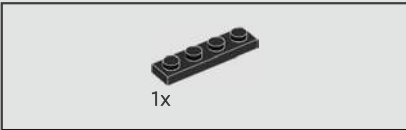
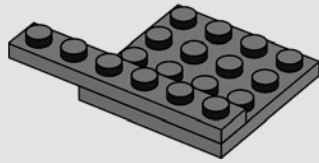

31

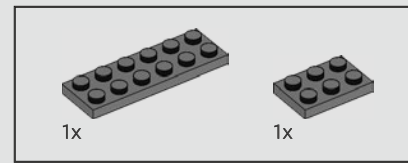
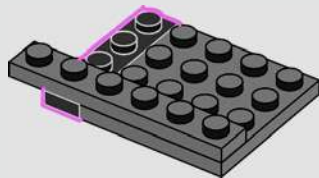

32

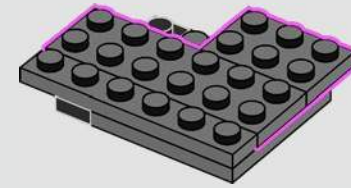

33

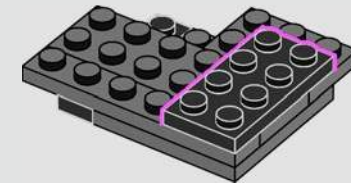

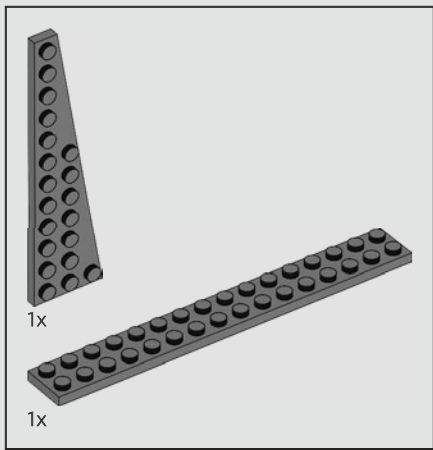

34

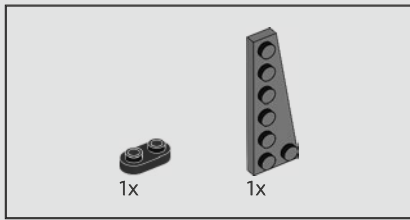
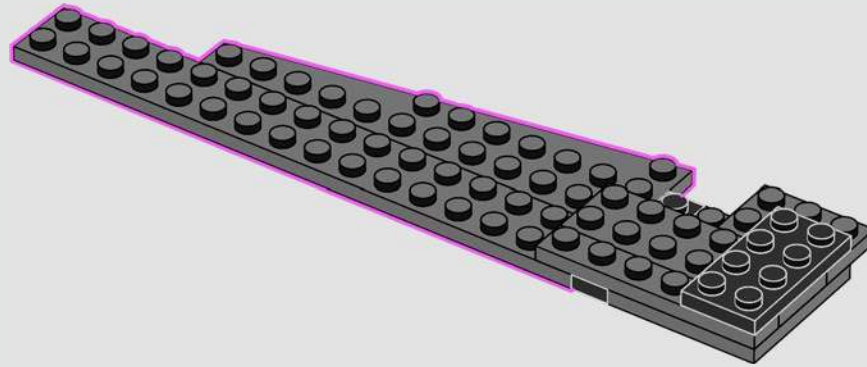

35

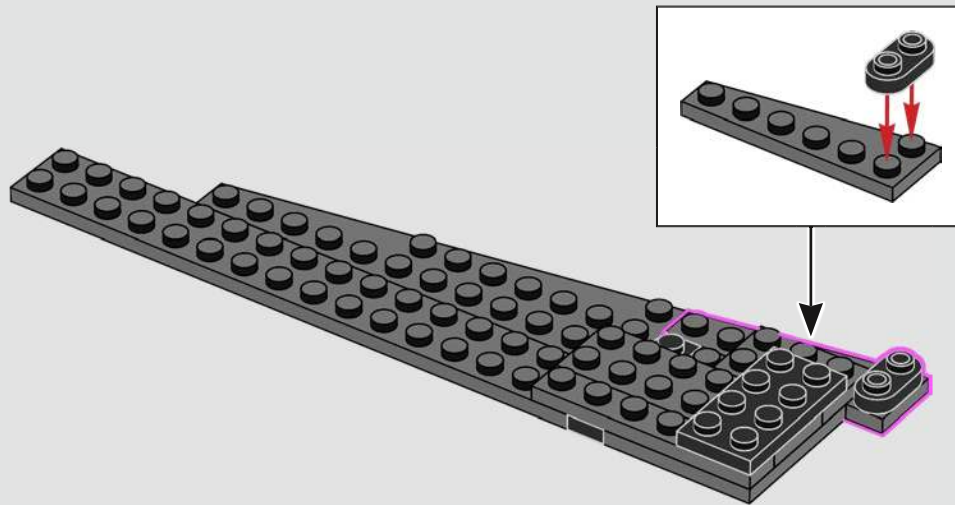

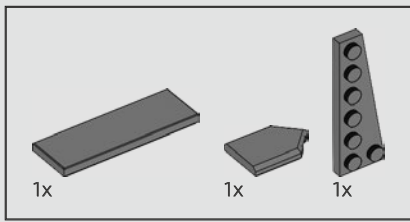

36

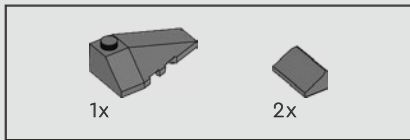
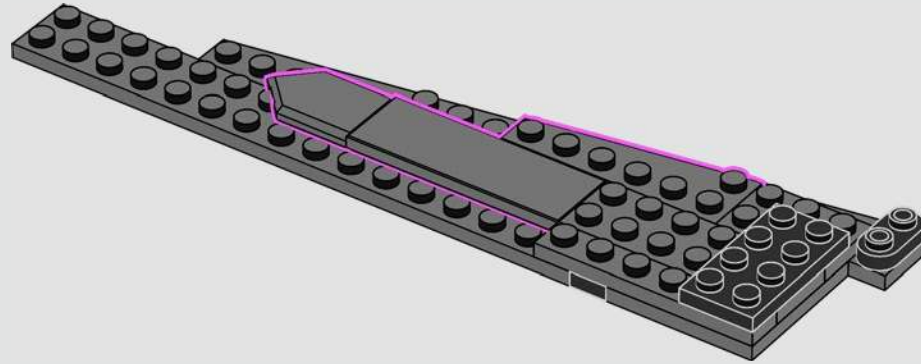

37

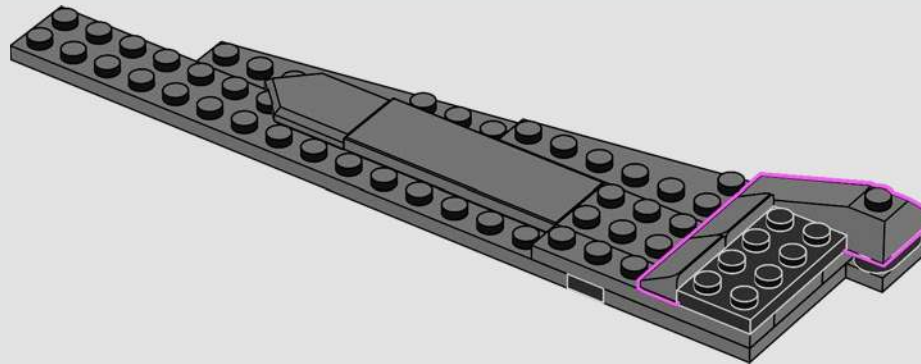

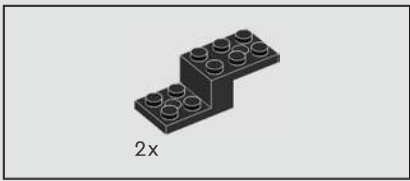

38

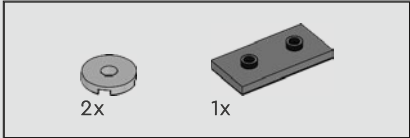
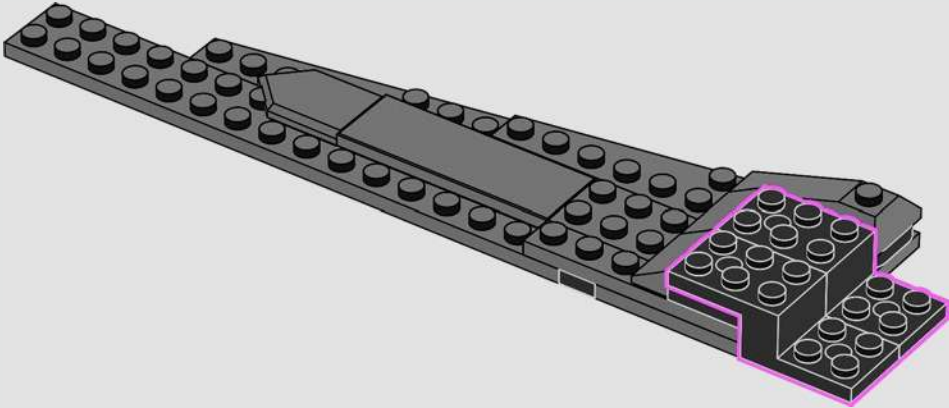

39

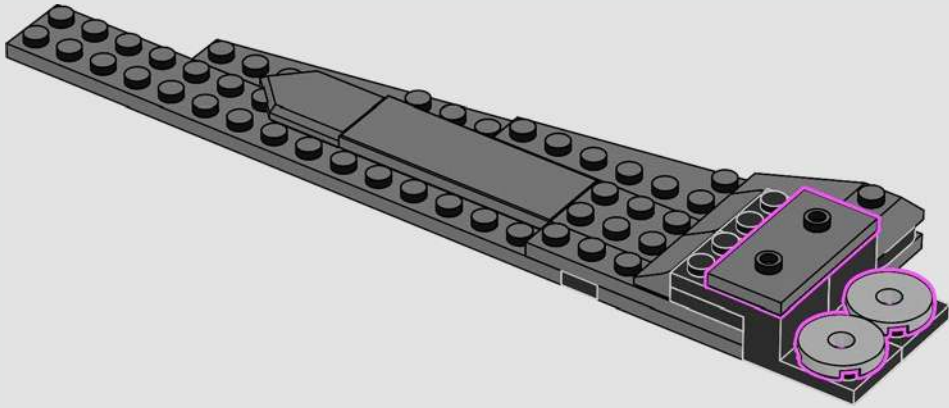



The tail will form the handle to hold the vehicle,
so it's important that it's super strong!

40

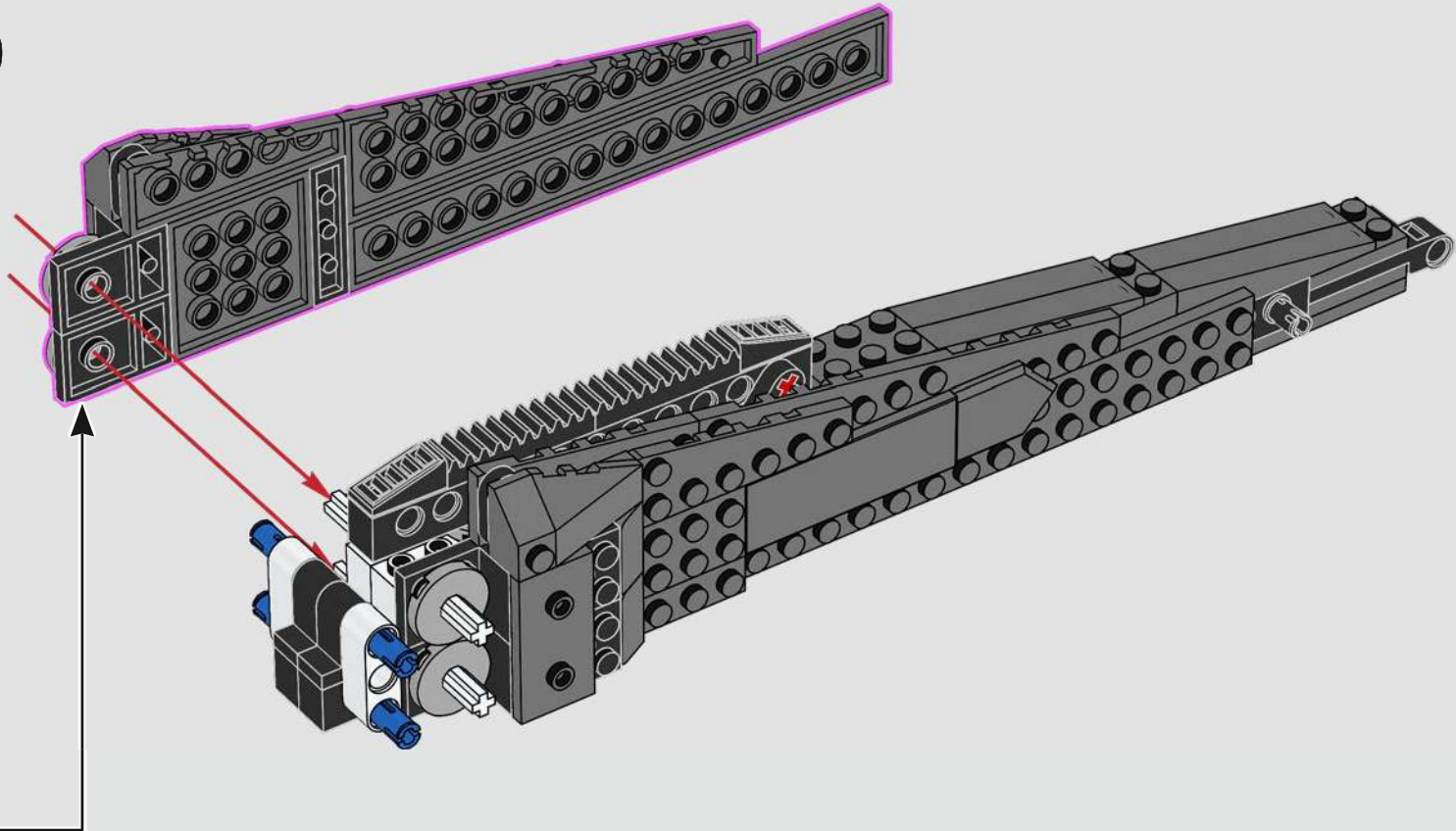



41

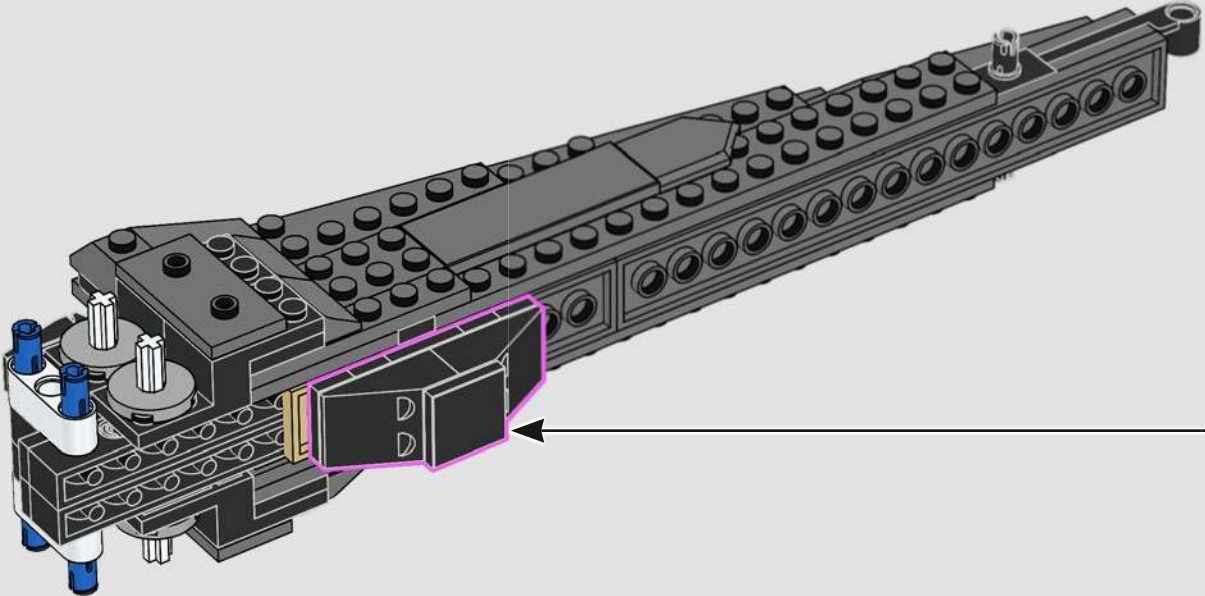
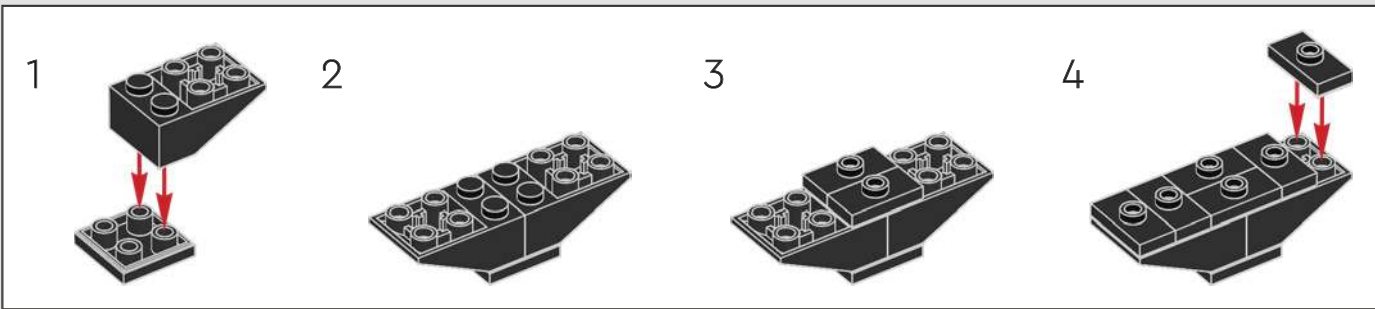

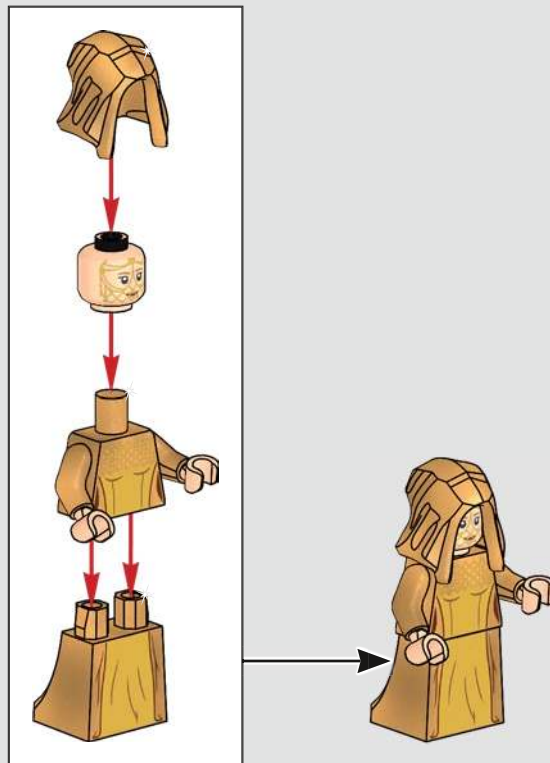
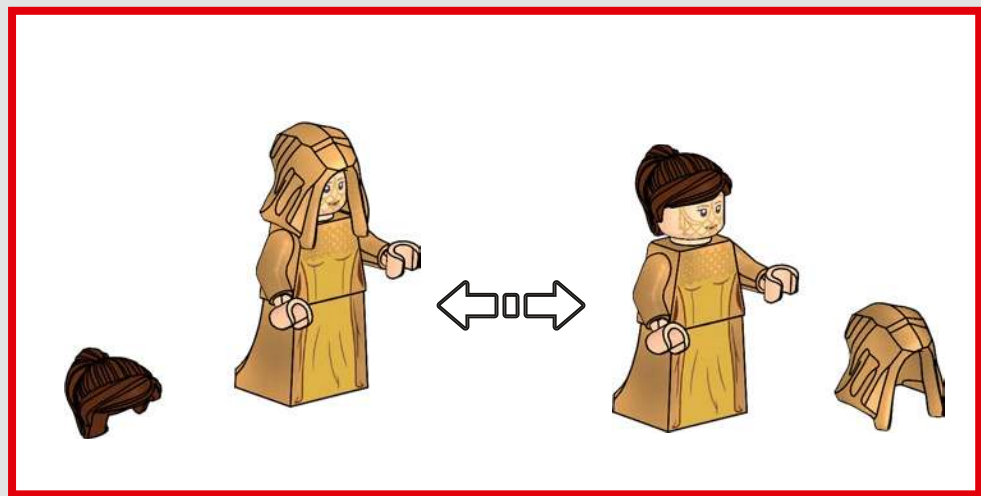

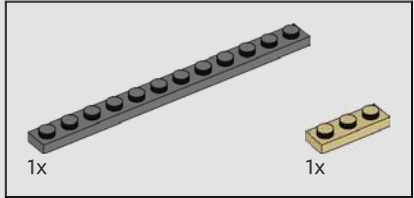
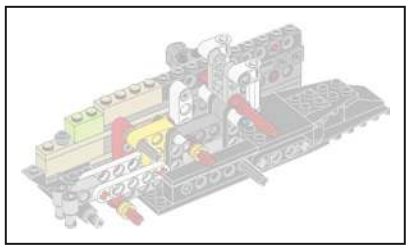

42

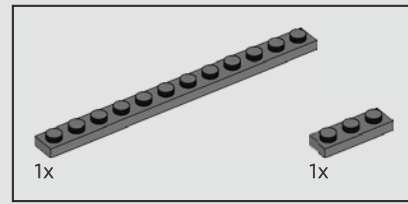
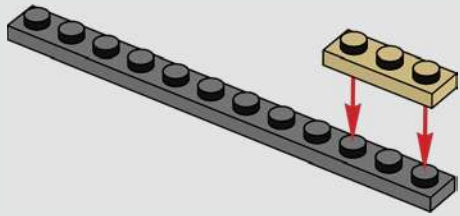

43

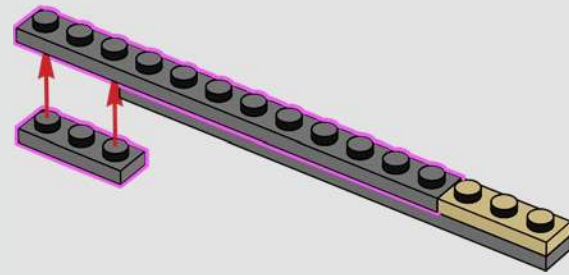

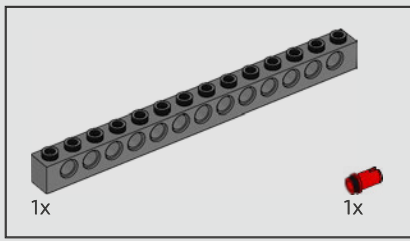

44

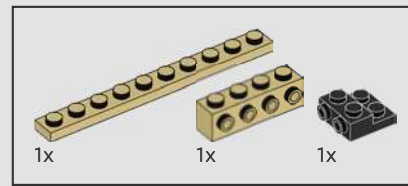
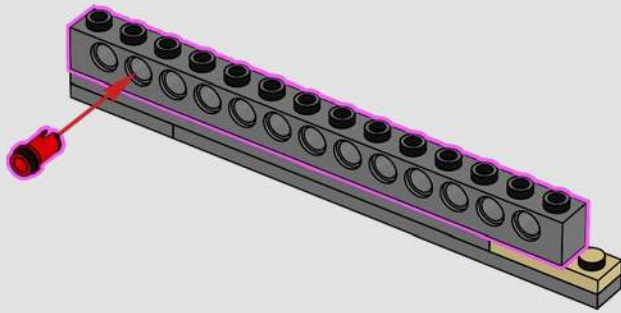

45

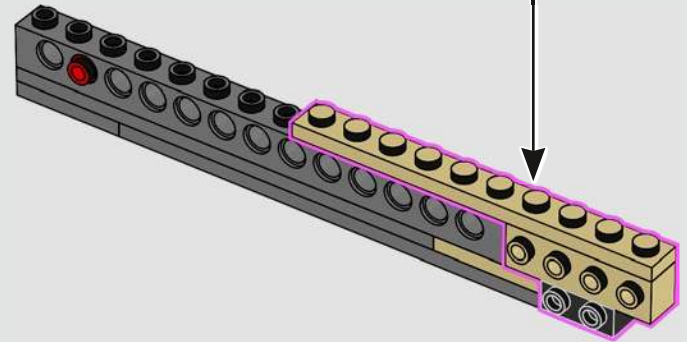
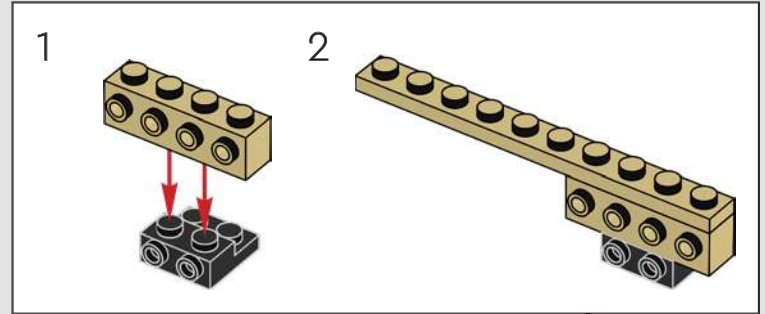

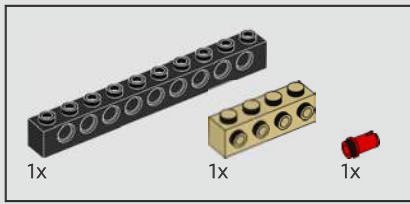

48

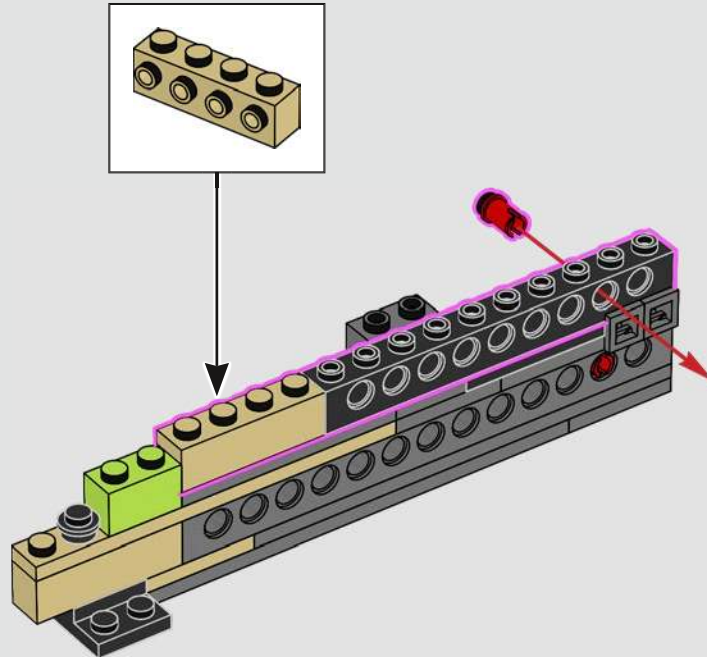

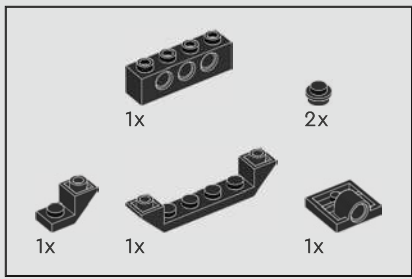

49

1

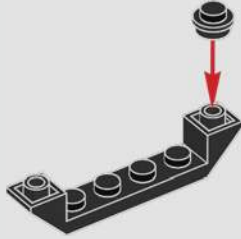

2

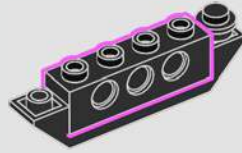

3

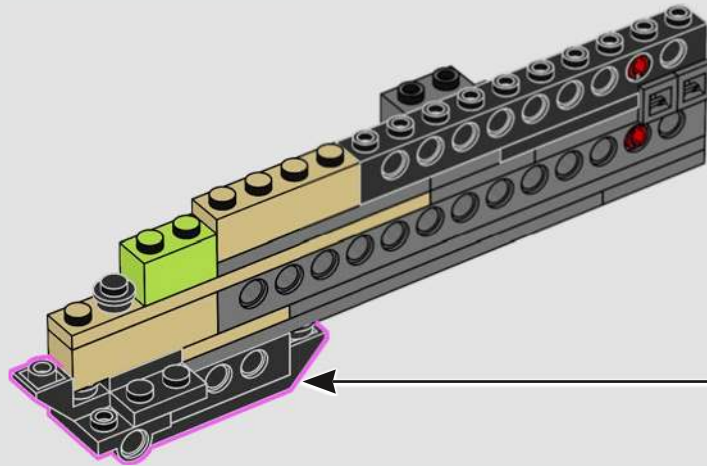
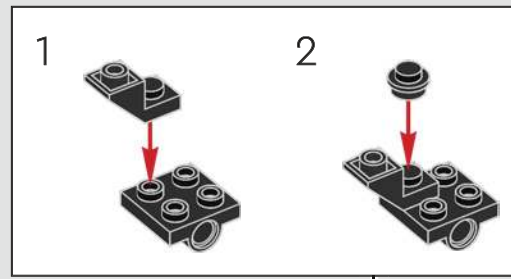
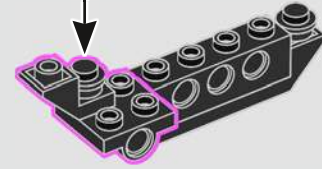

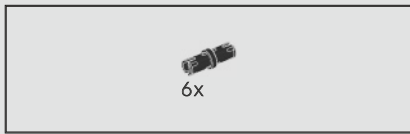

50

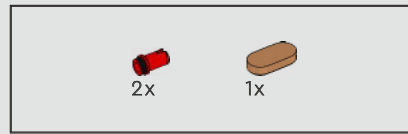
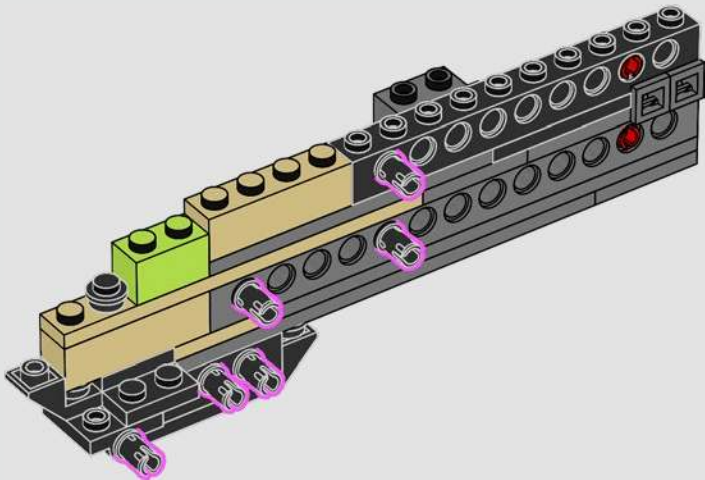

51

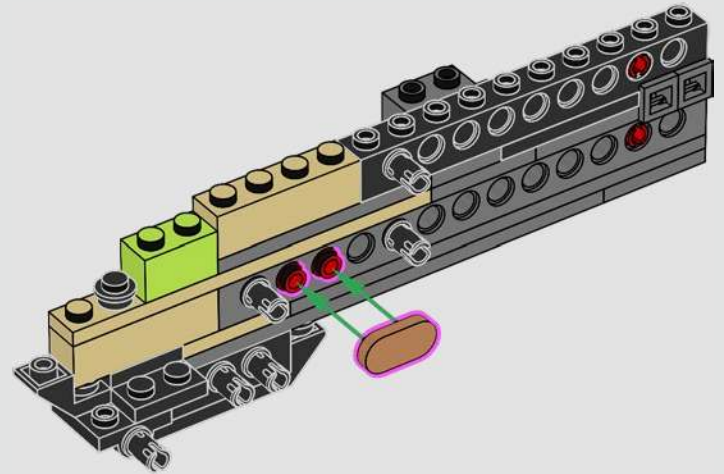

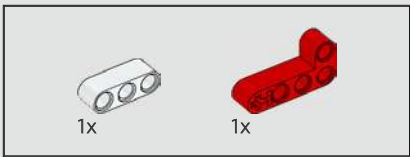

52

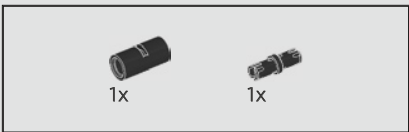
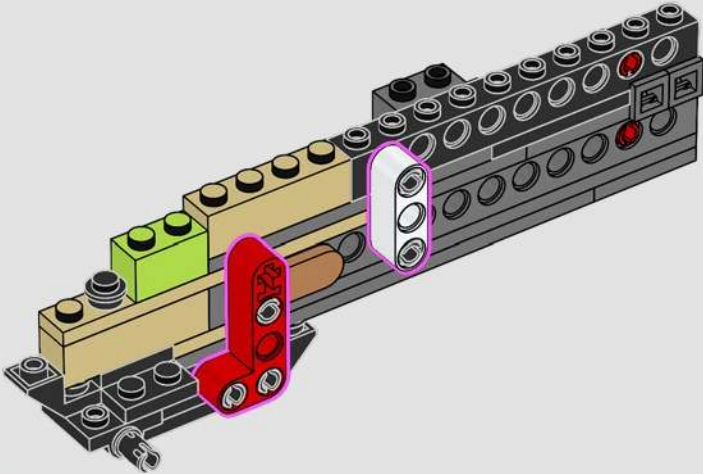

53

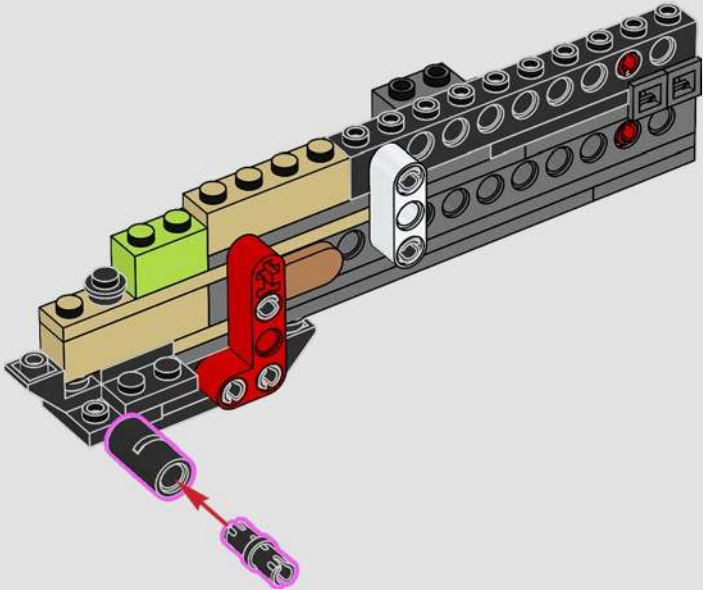

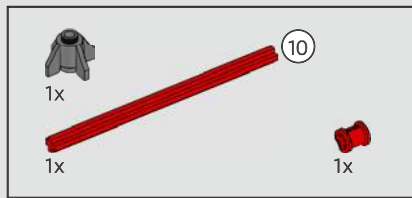

54

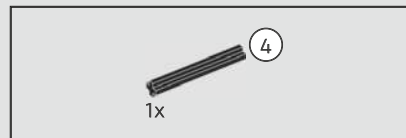
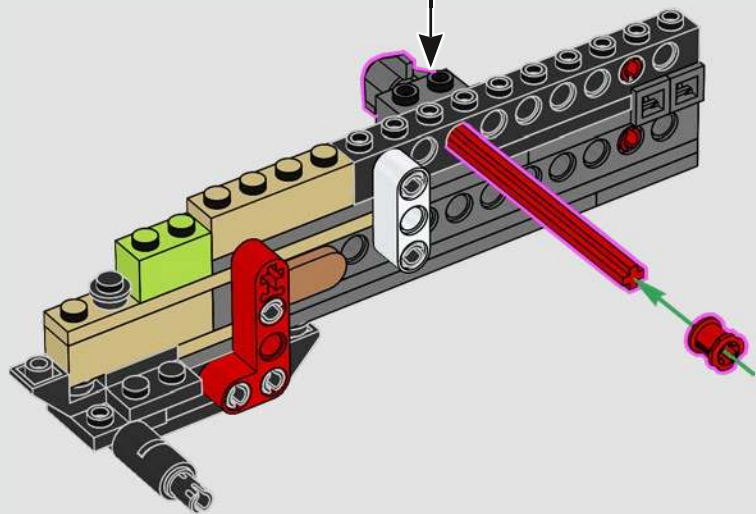
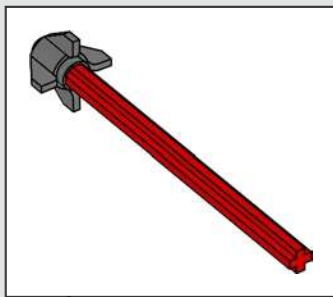

55

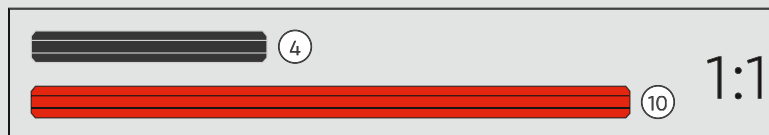
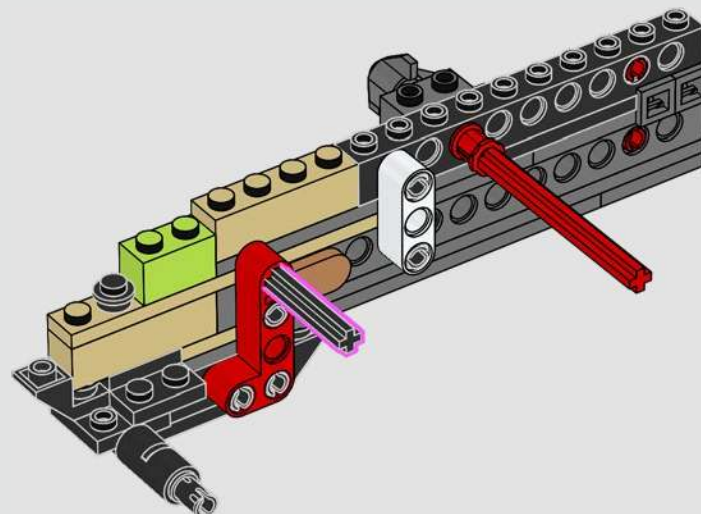

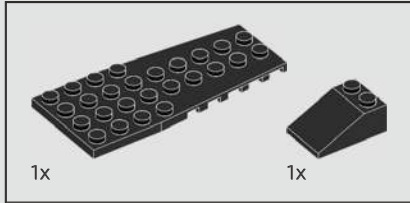
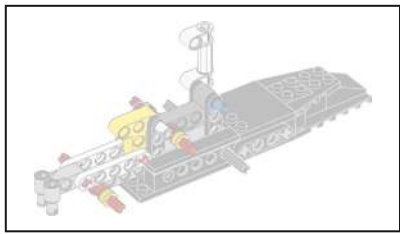

56

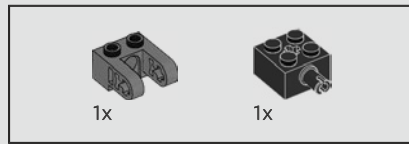
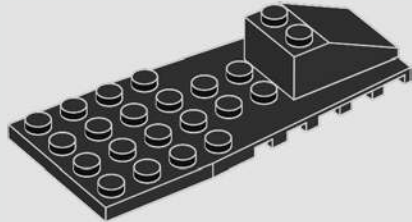

57

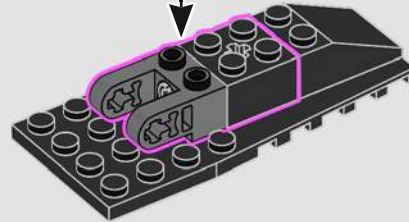
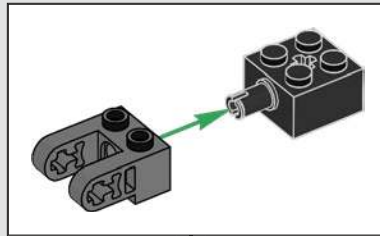

58

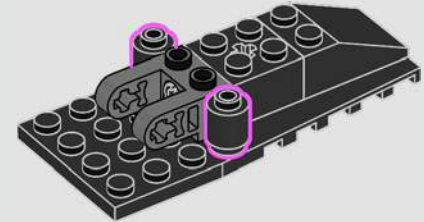

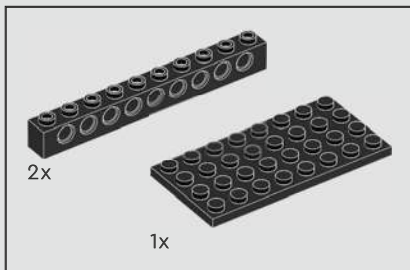

59

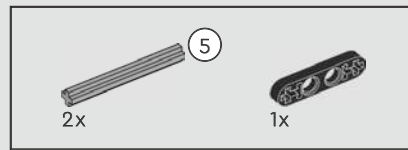
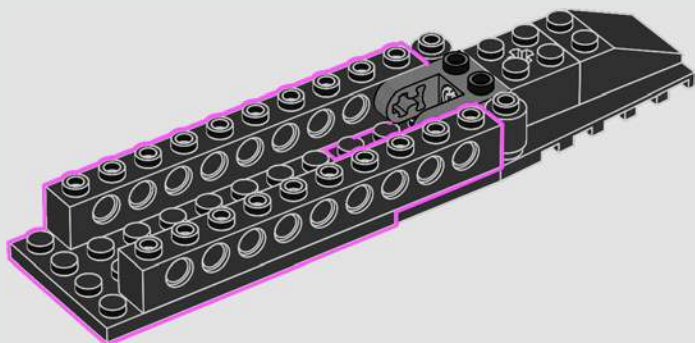

60

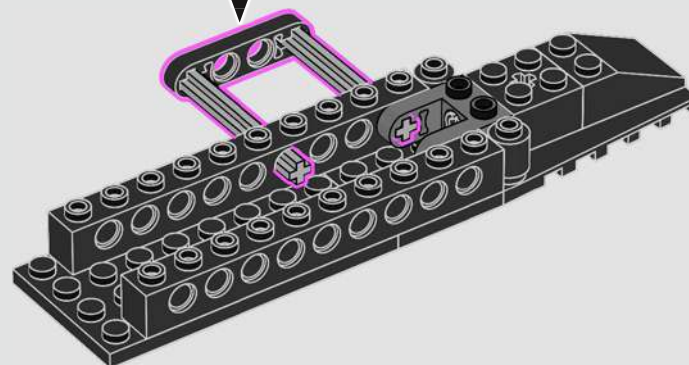

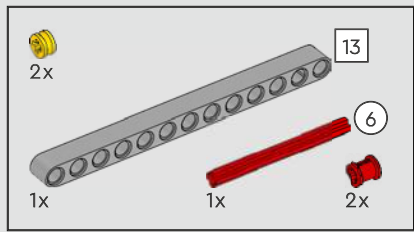

61

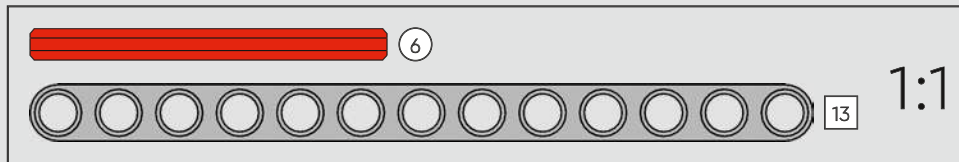
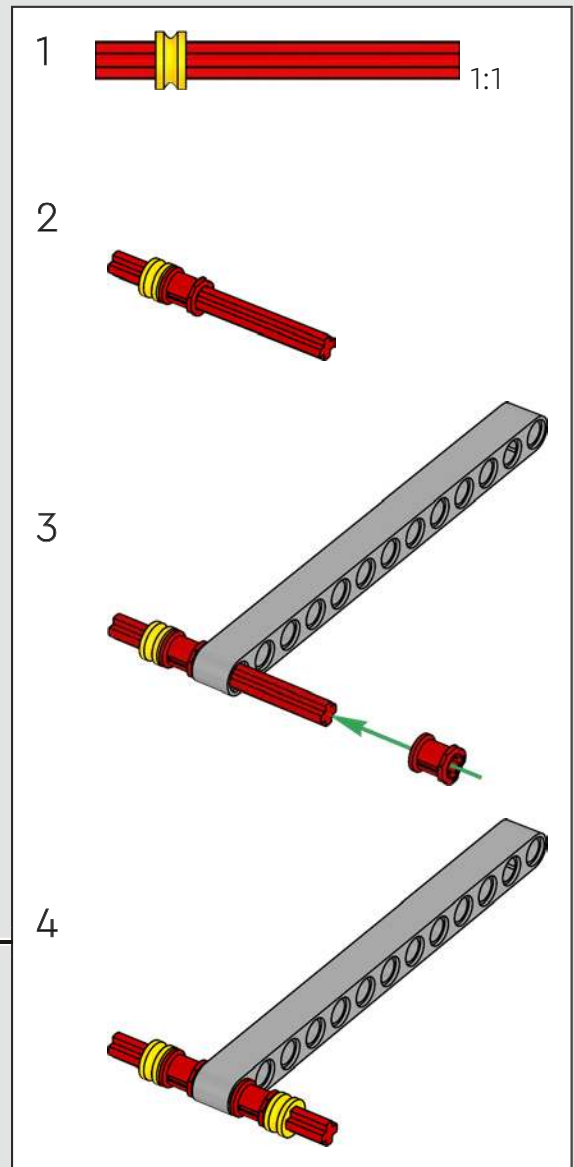
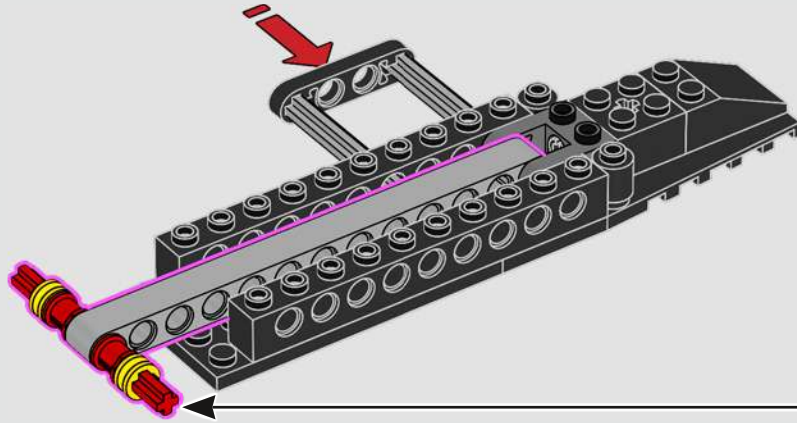

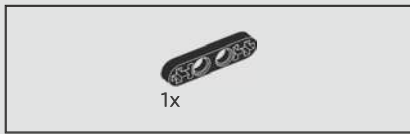

62

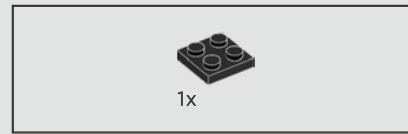
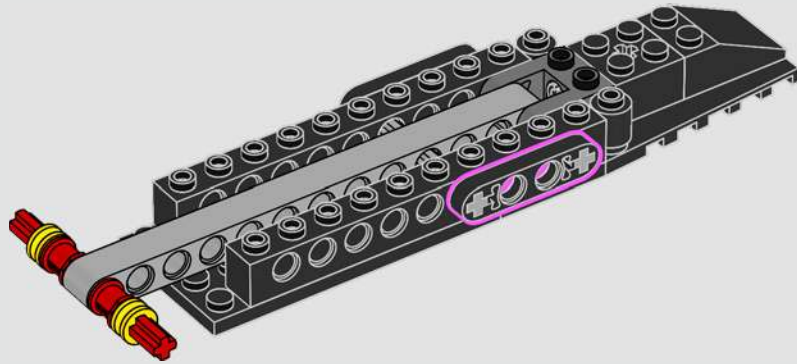

63

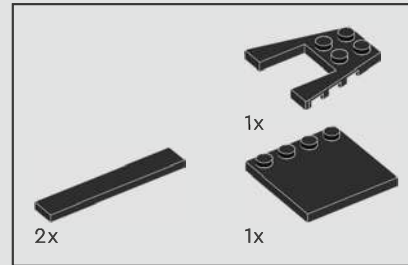
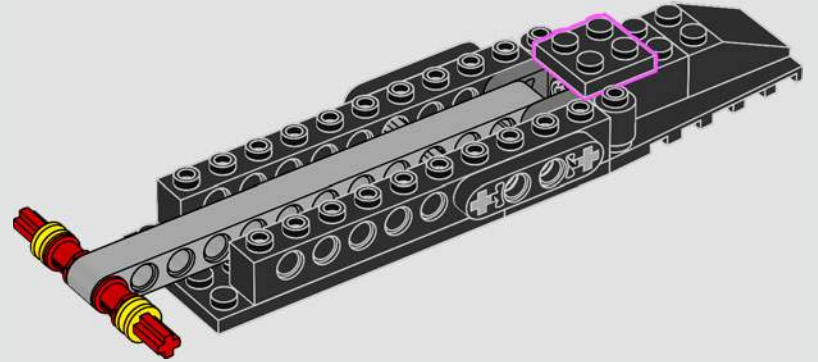

64

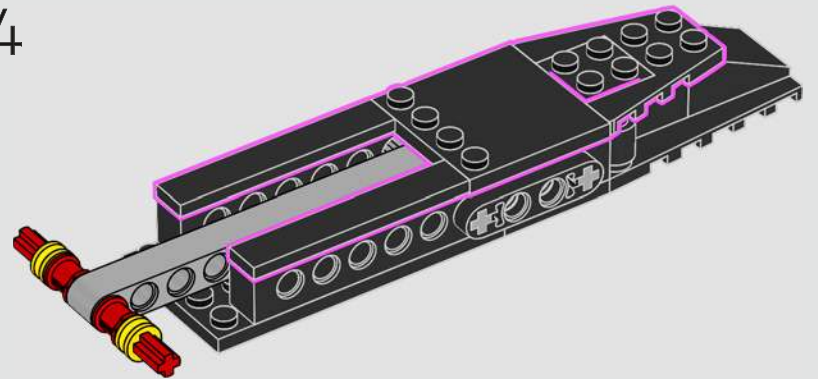

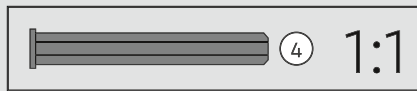
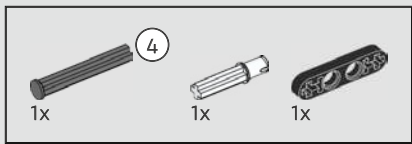

65

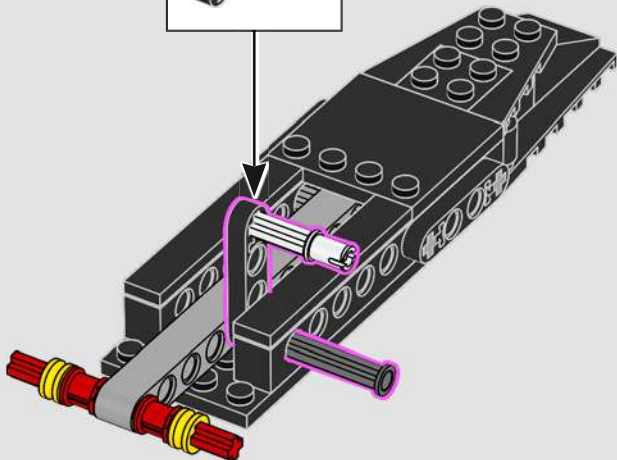

66

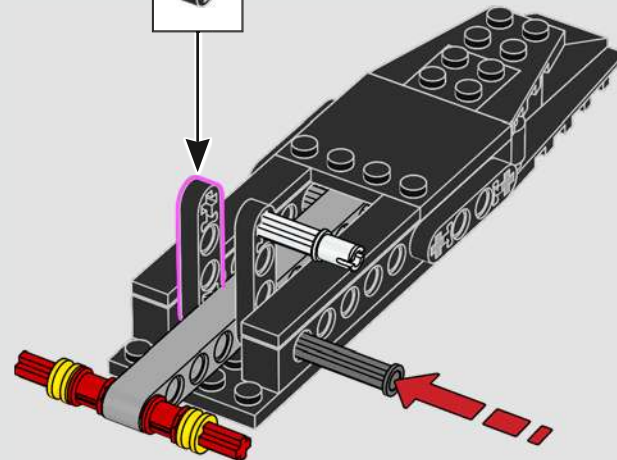

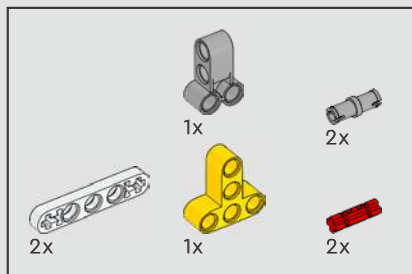

67

1

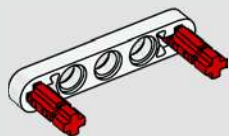

2

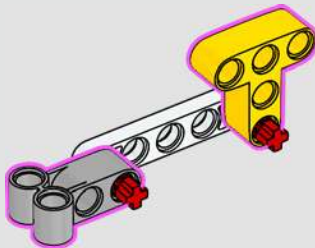

3

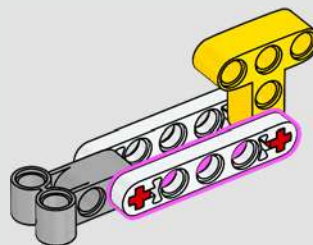

4

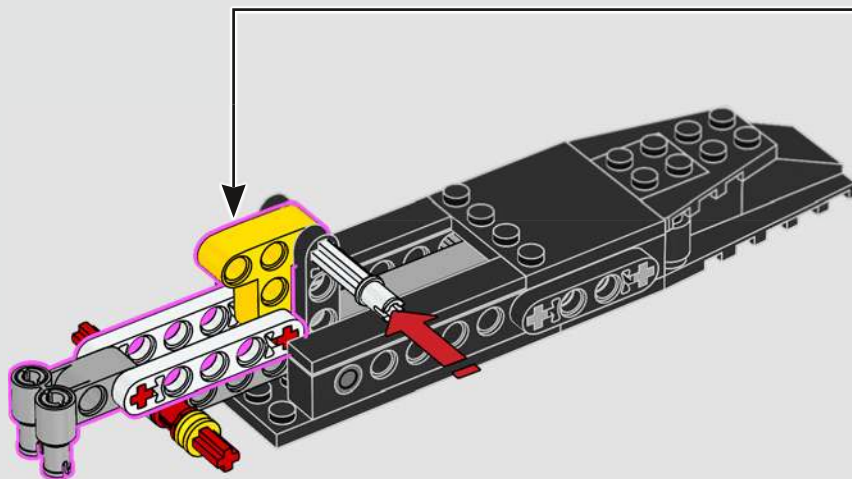
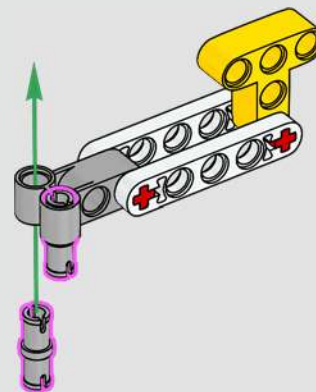

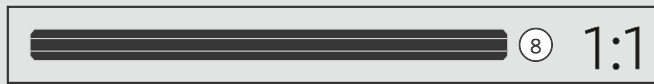
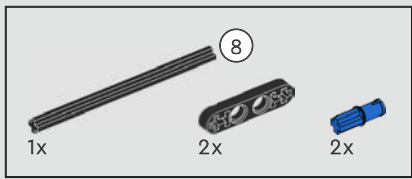

68

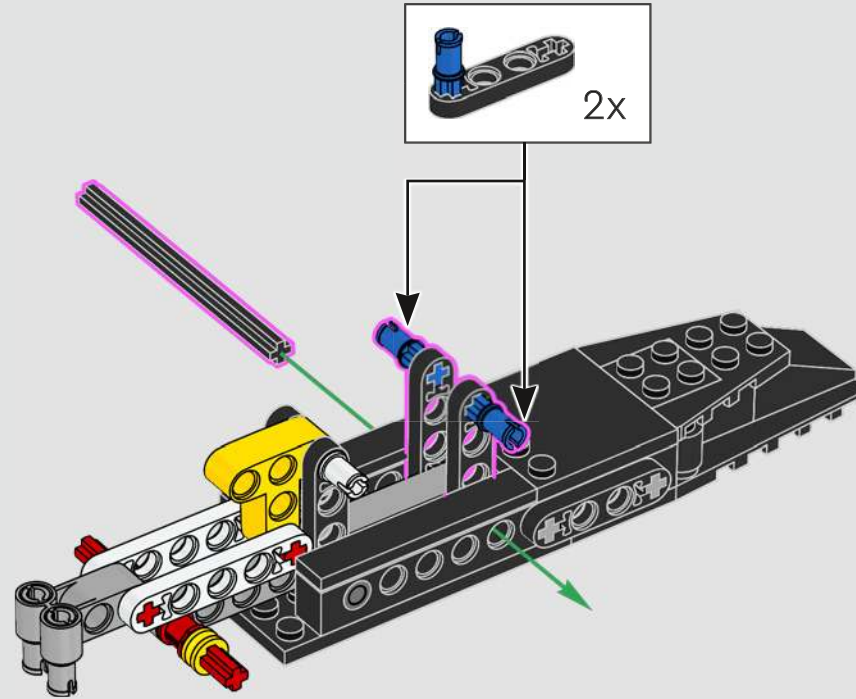

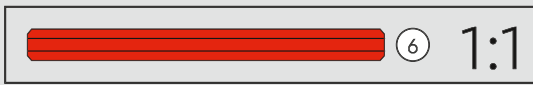
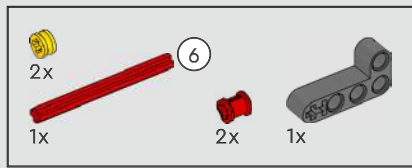

69

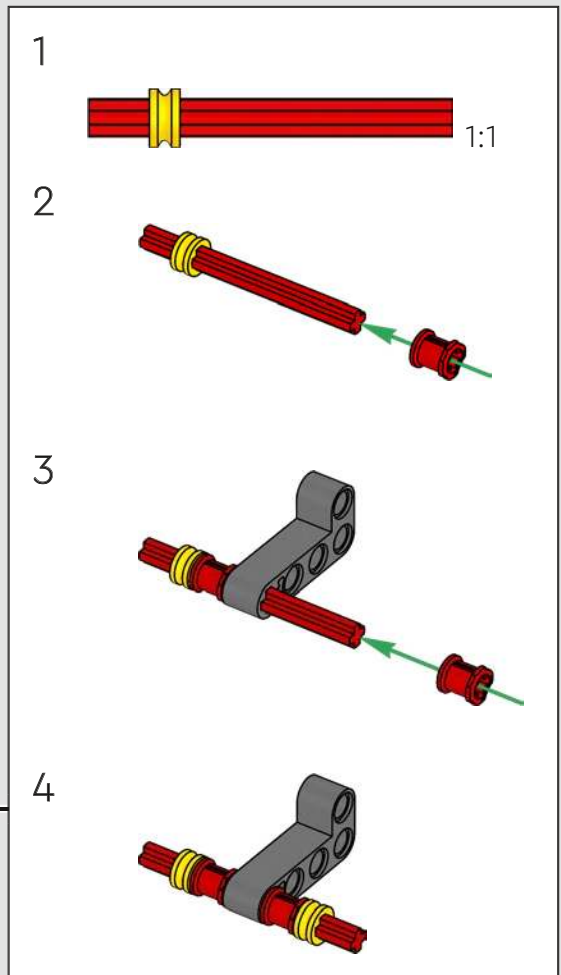
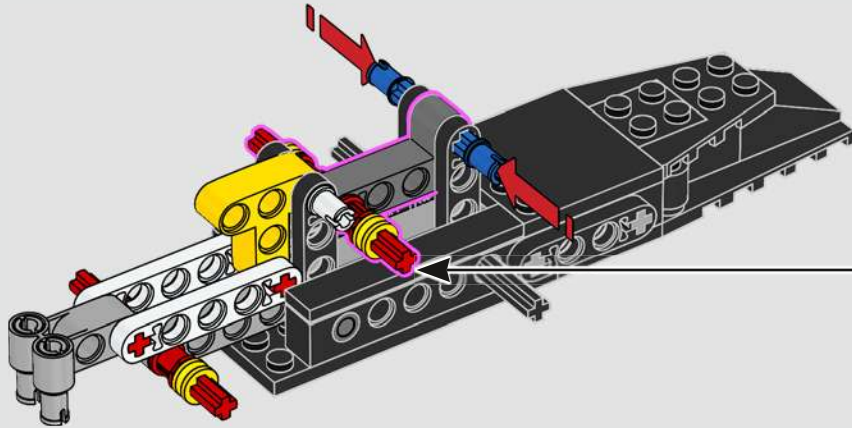

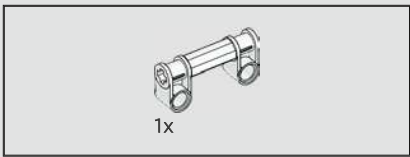

70

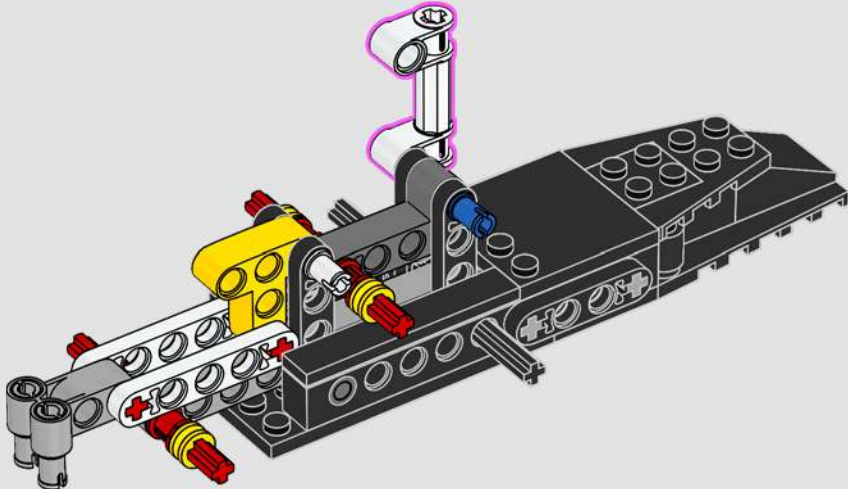

71

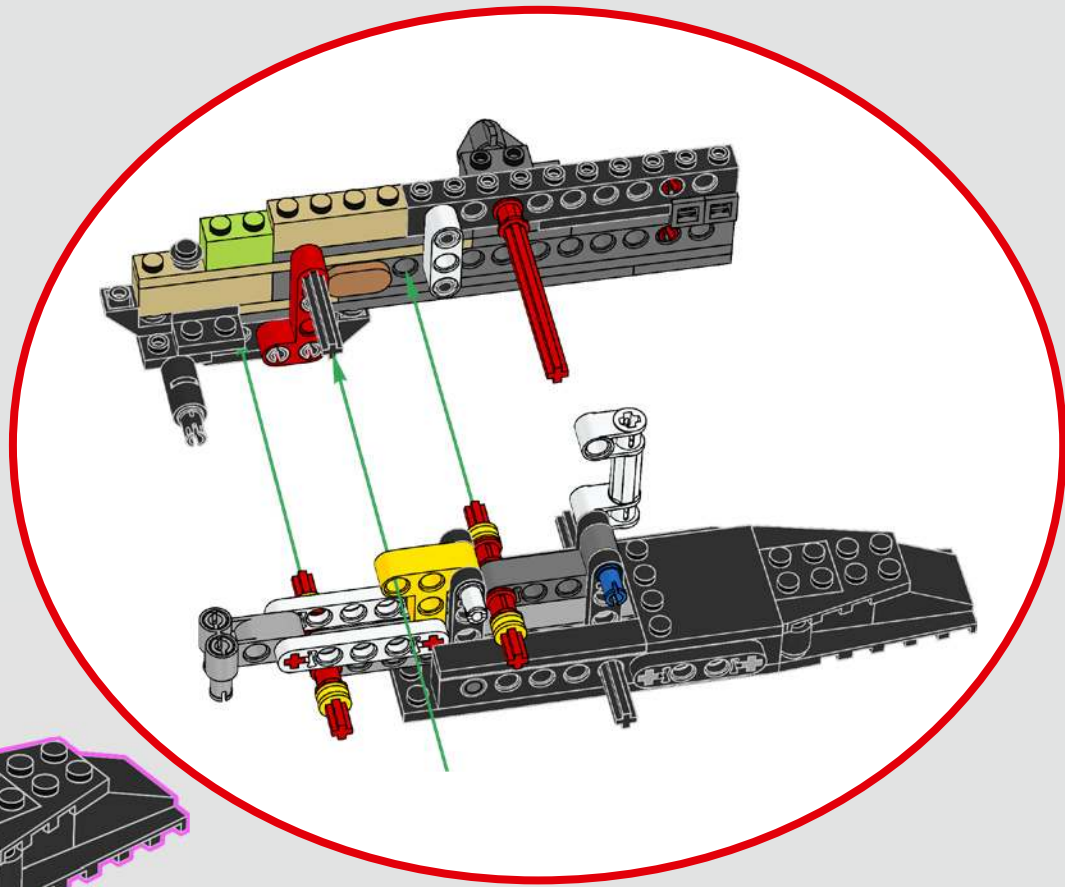
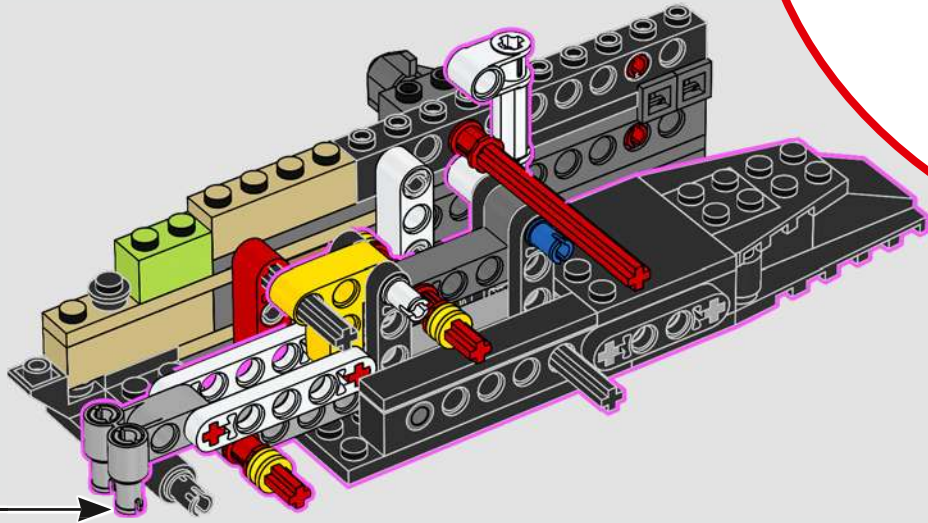

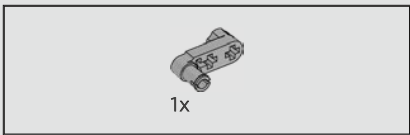

72

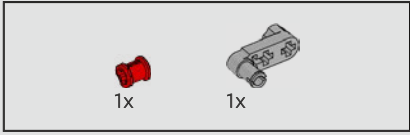
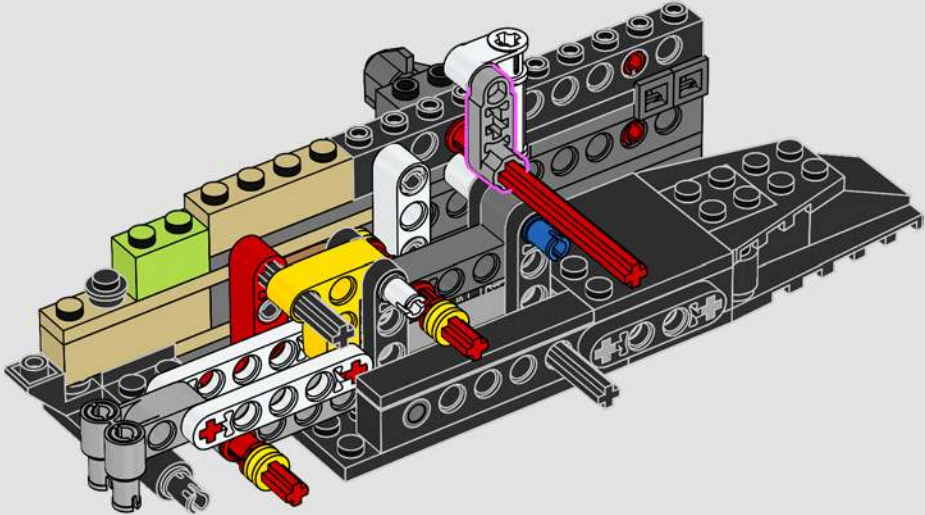

73

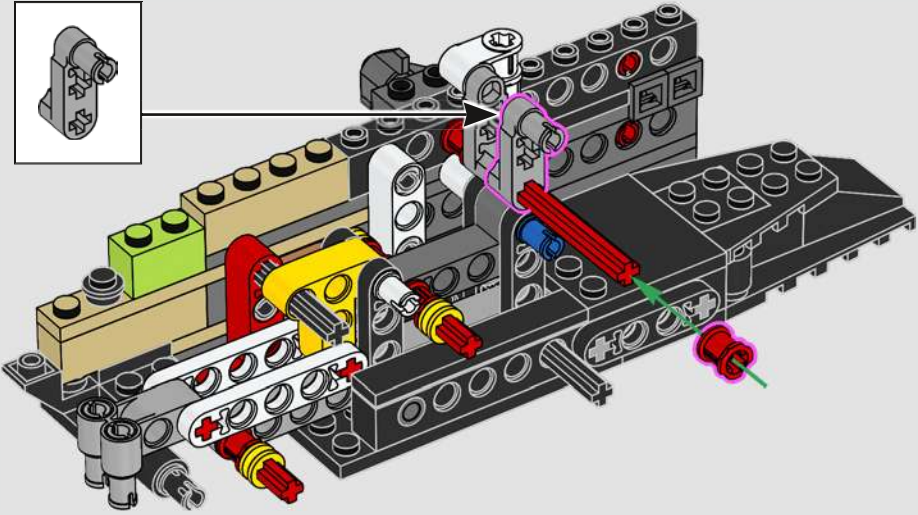
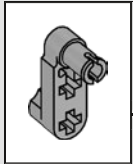

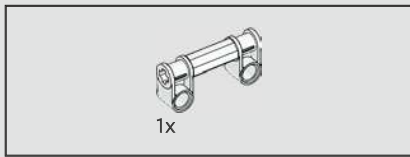

74

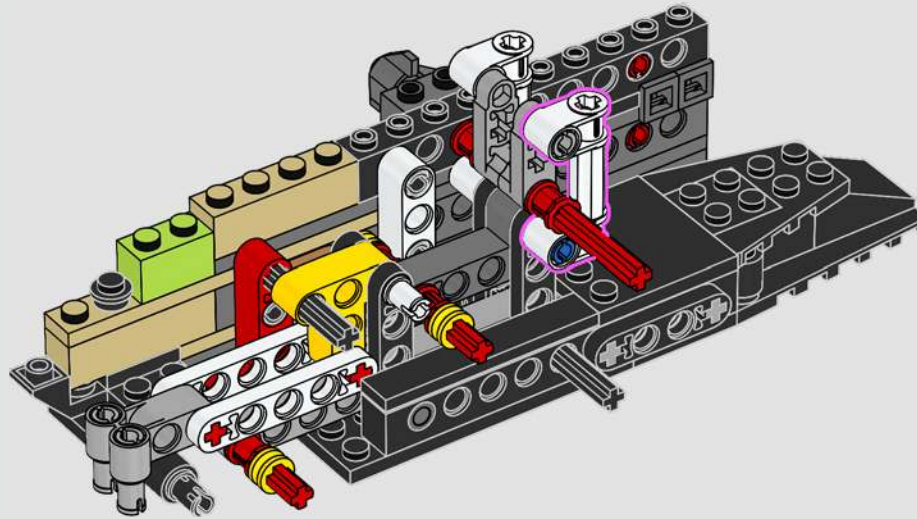

75

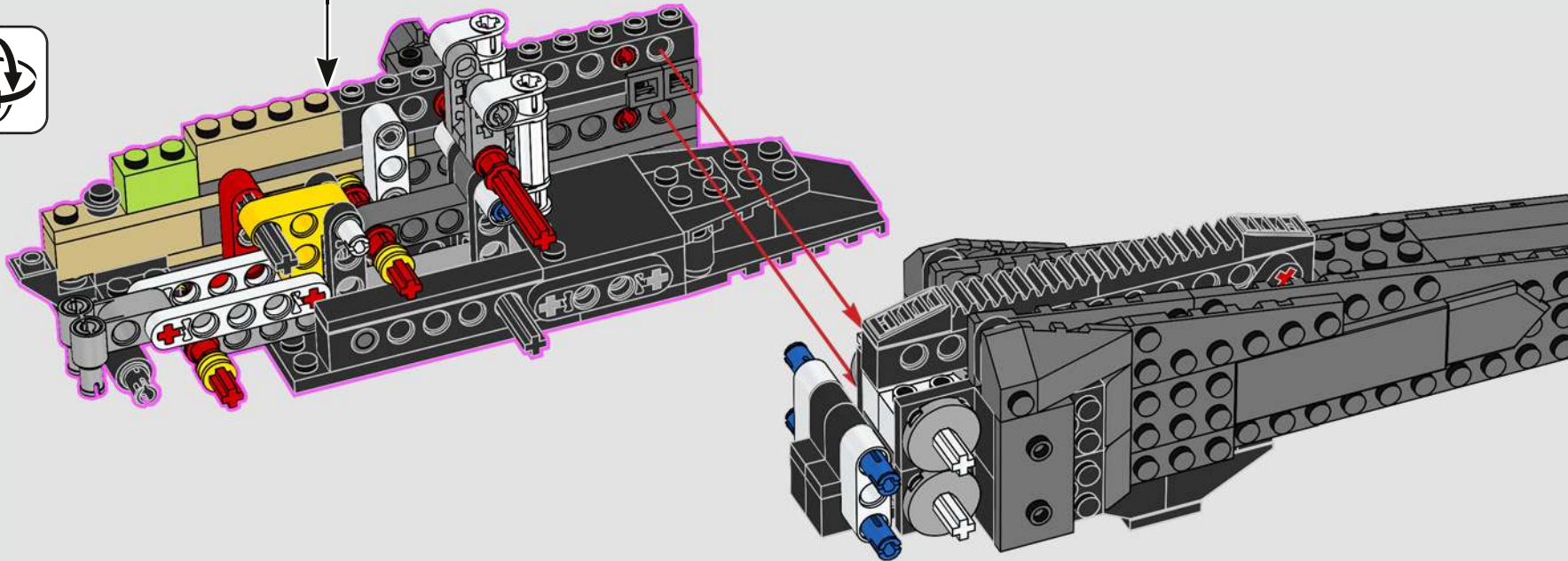

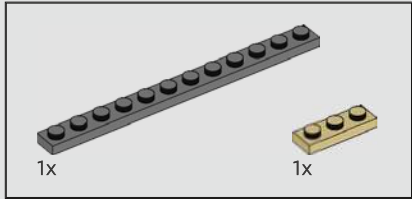
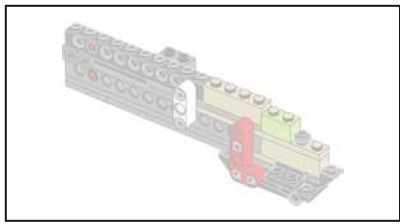

76

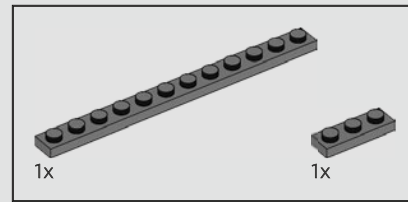
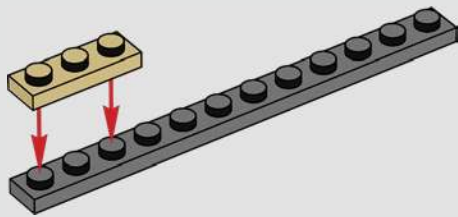

77

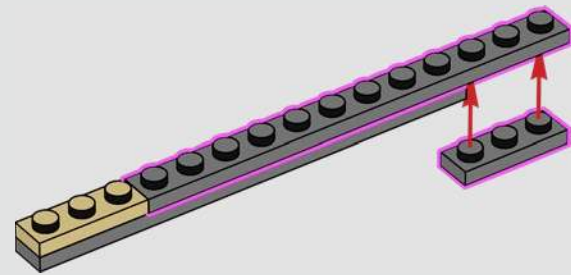

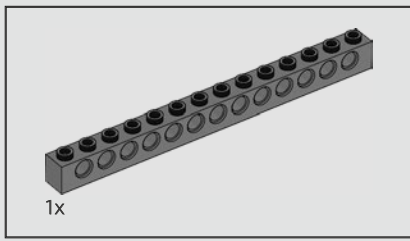

78

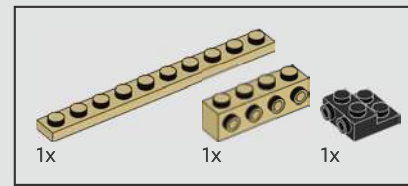
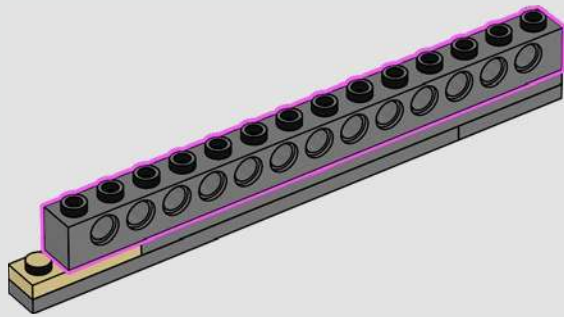

79

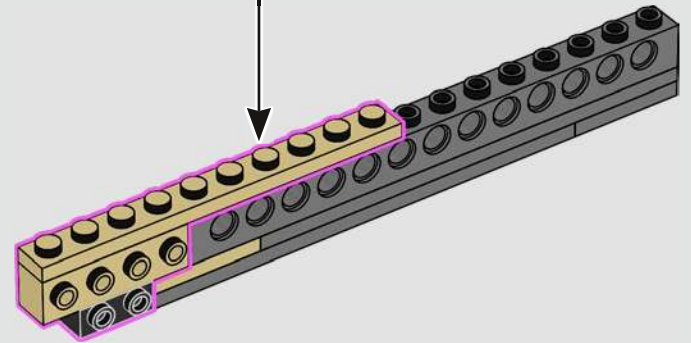
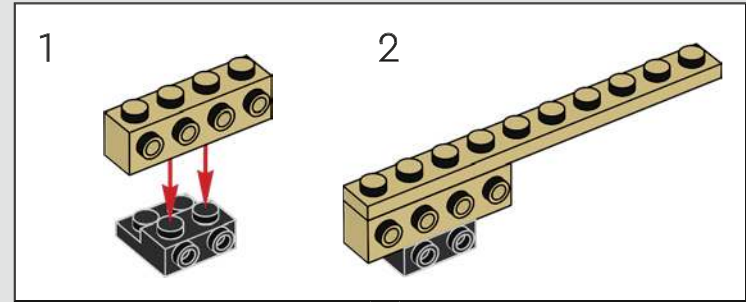

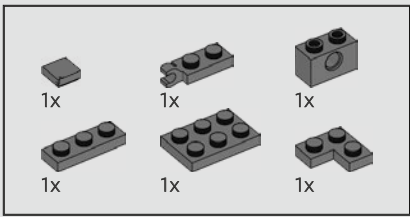

80

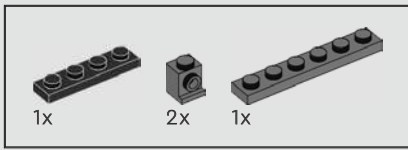
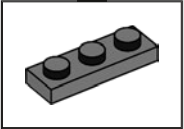
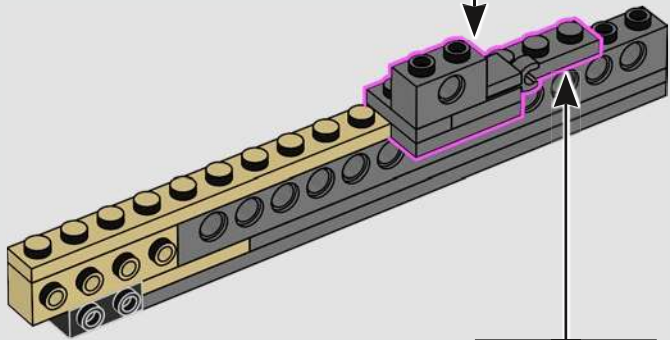
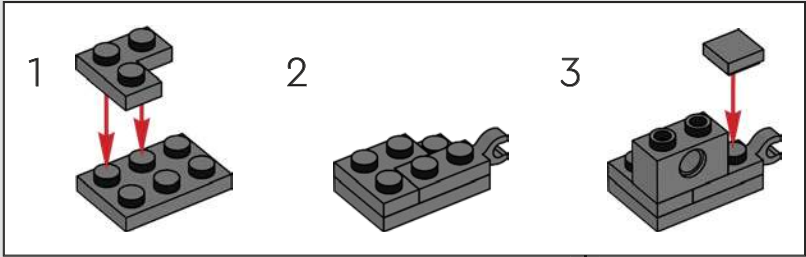

81

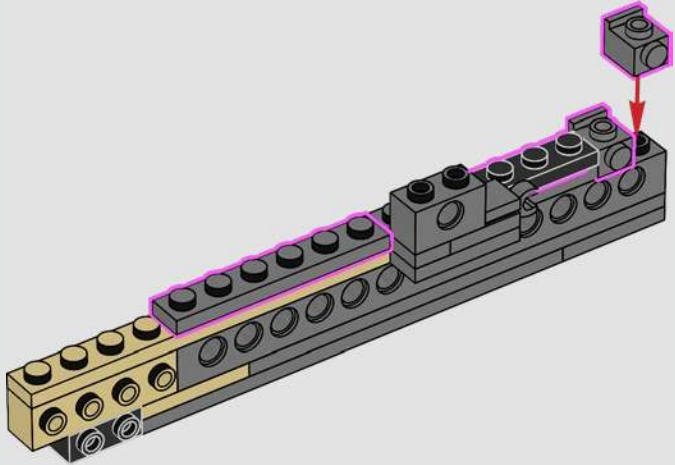

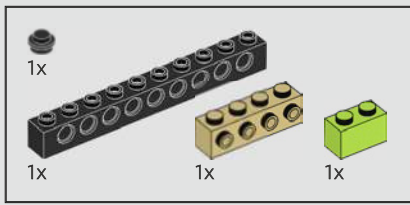

82

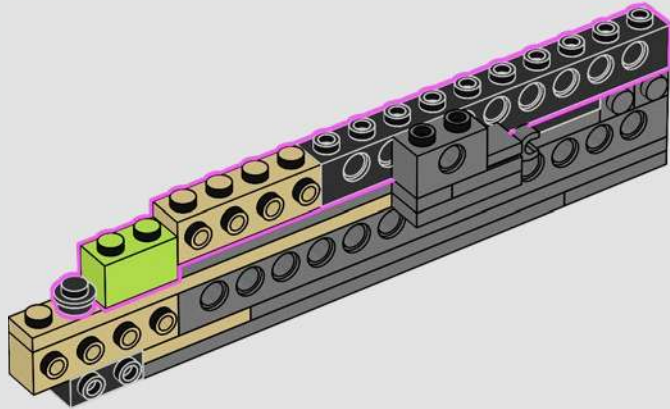

83

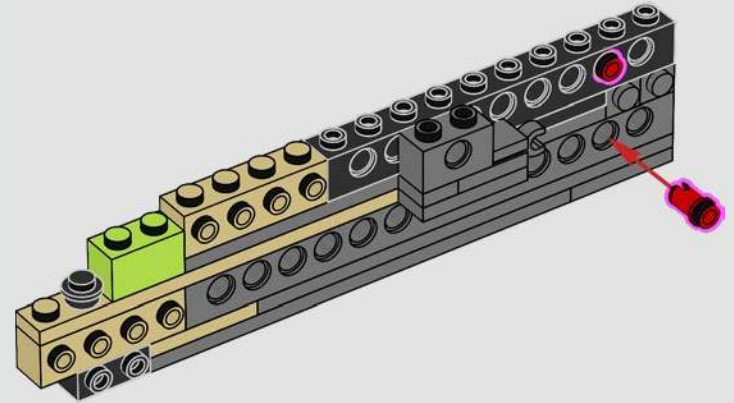

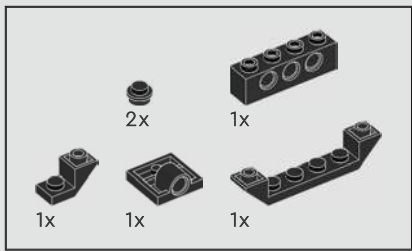

84

1

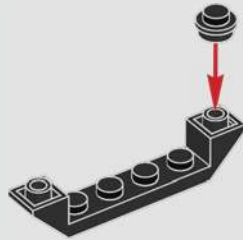

2

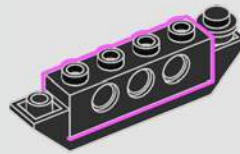

3

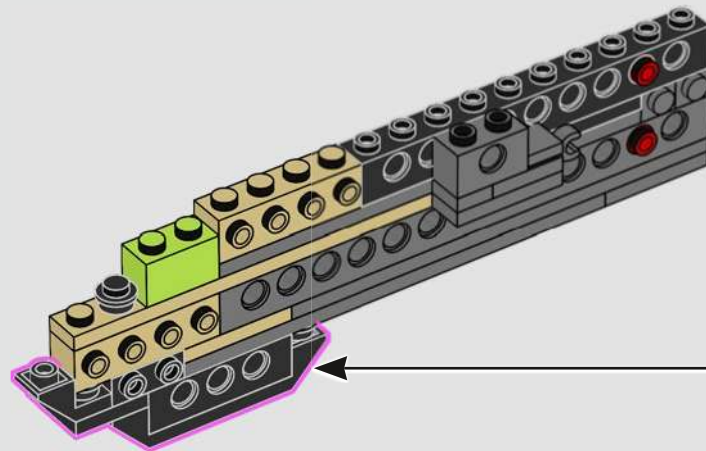
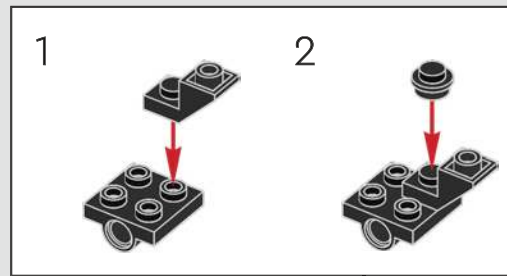
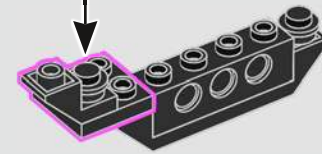



85

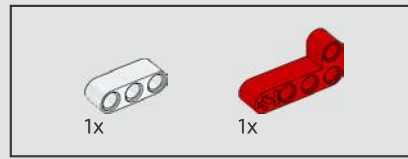
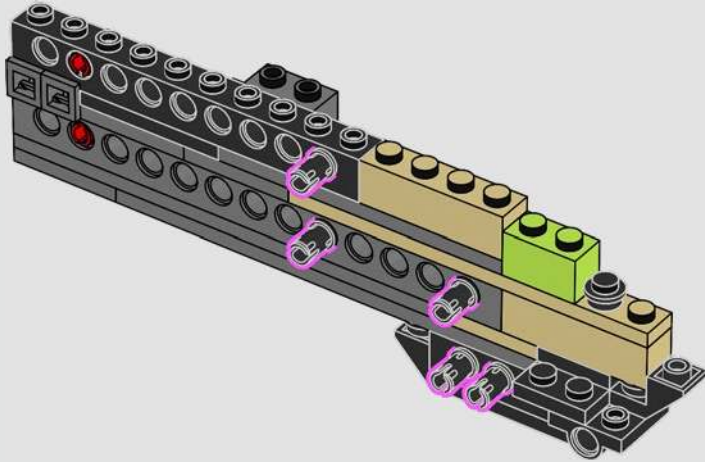

86

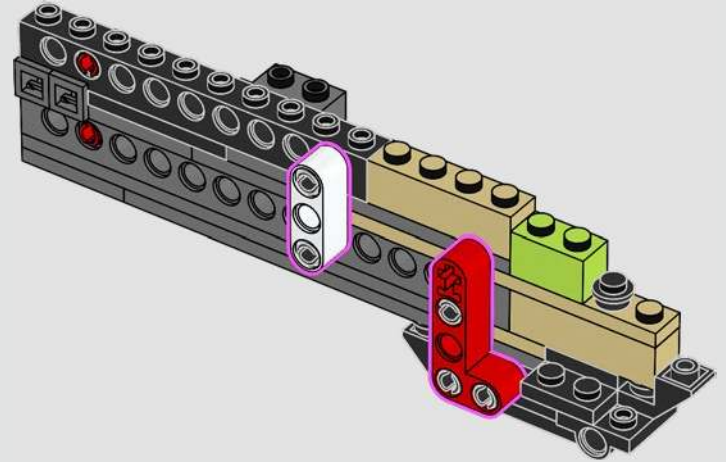

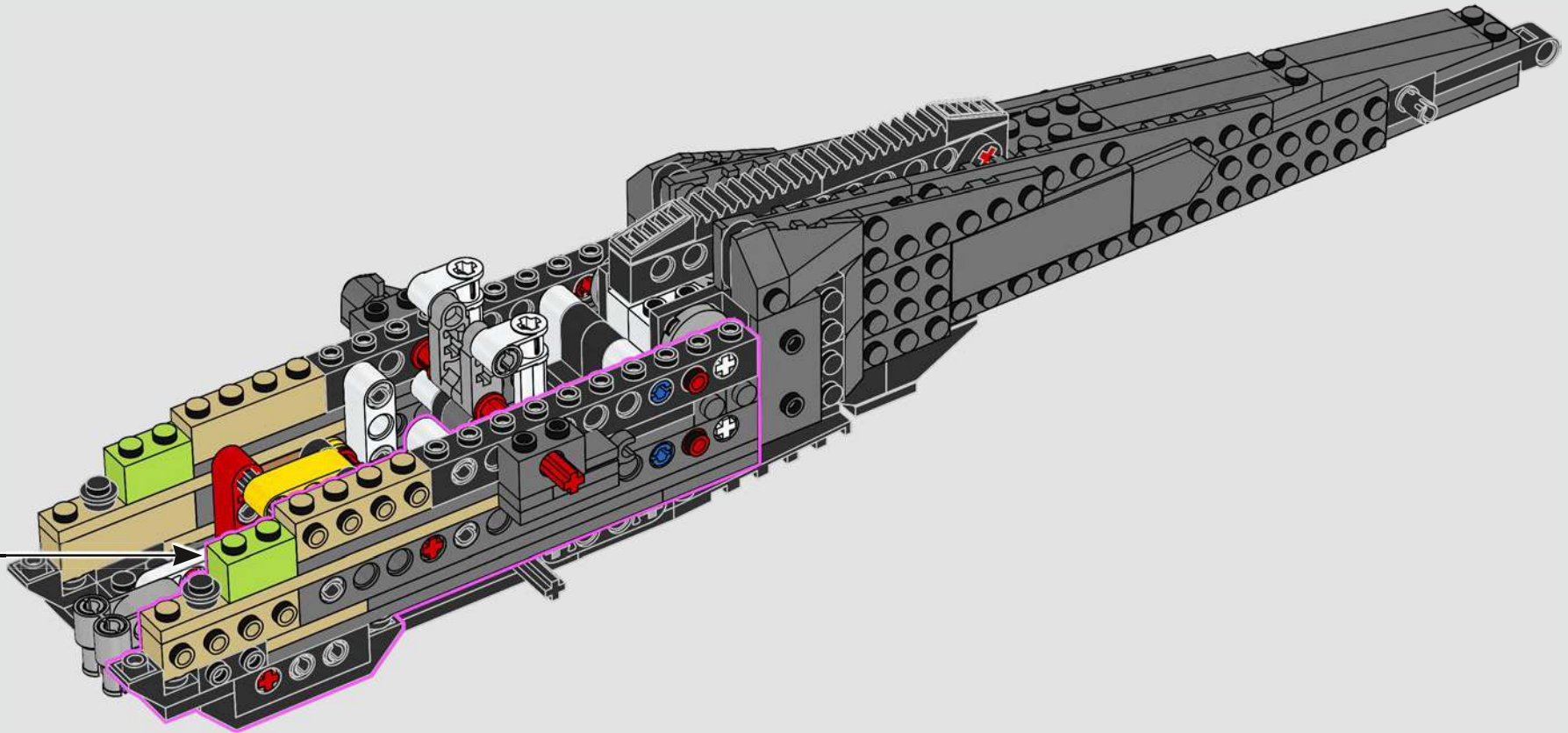



88

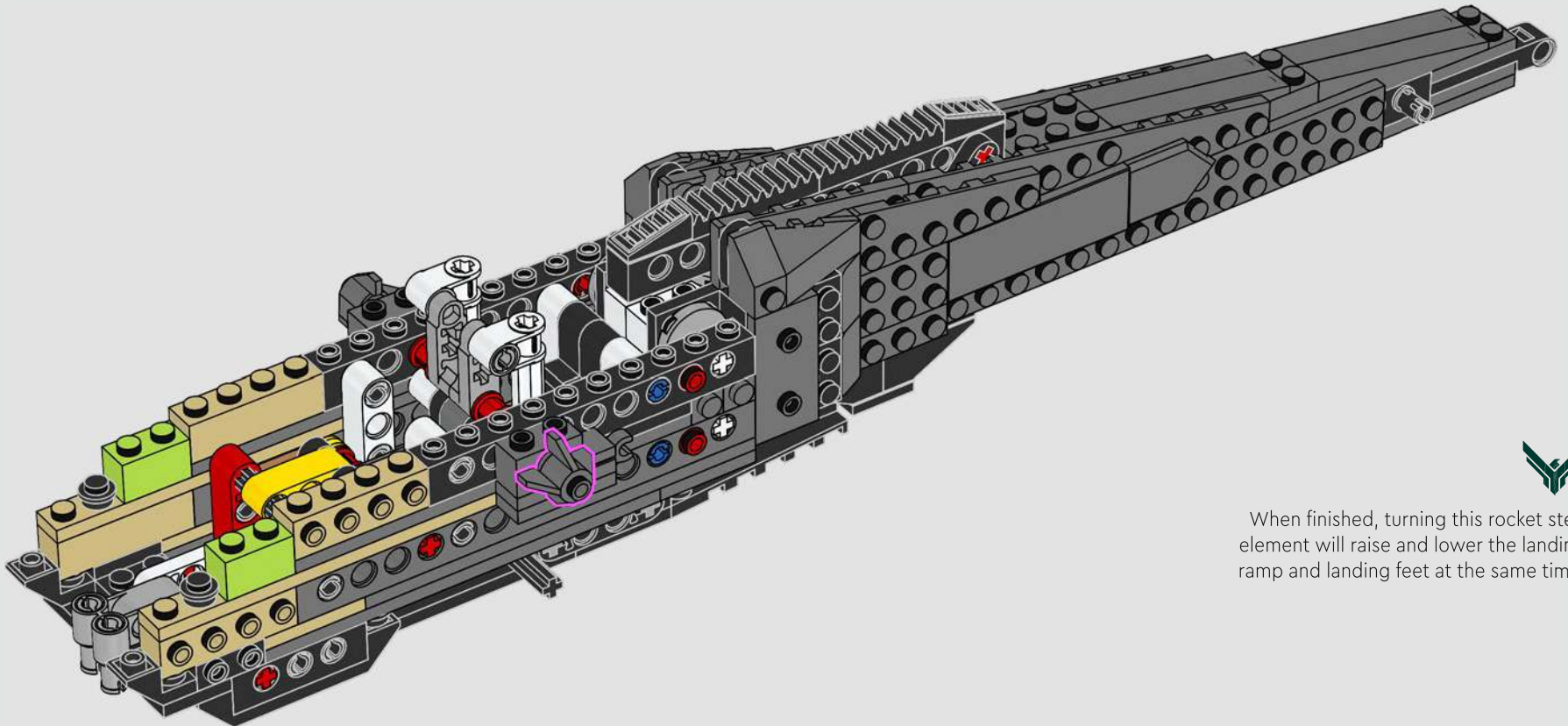

When finished, turning this rocket step element will raise and lower the landing ramp and landing feet at the same time.

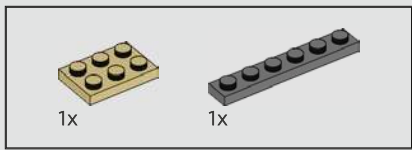

89

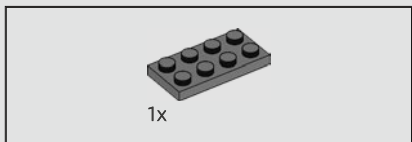
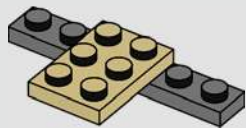

90

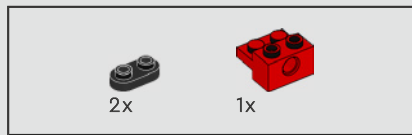
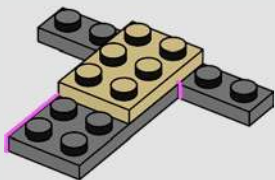

91

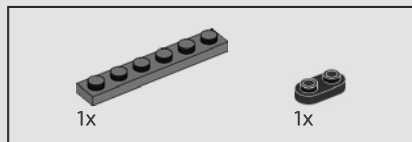
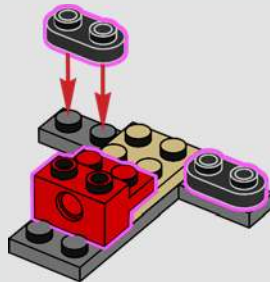

92

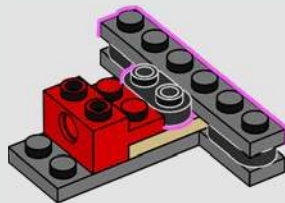

93

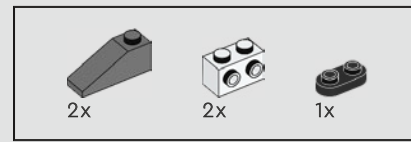
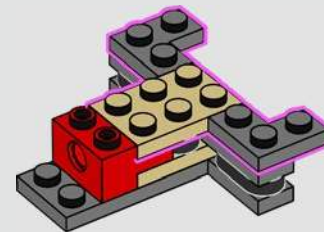

94

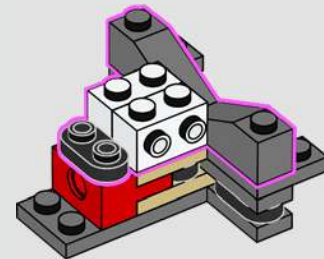

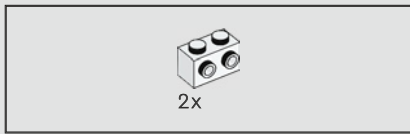

95

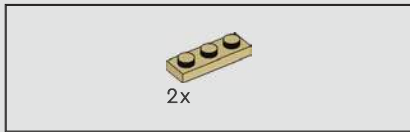
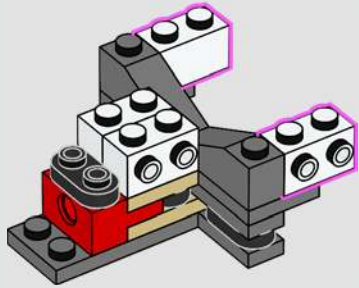

96

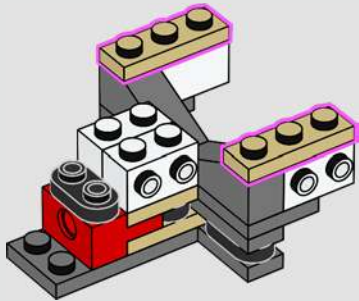

97

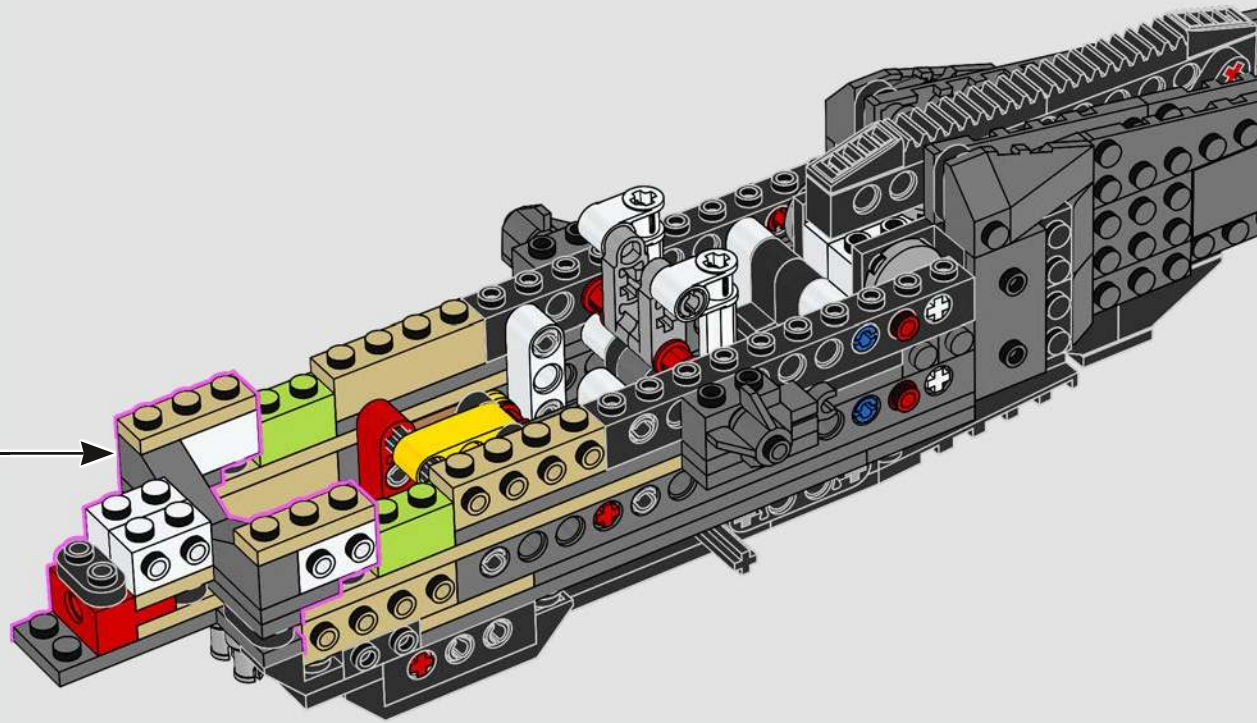

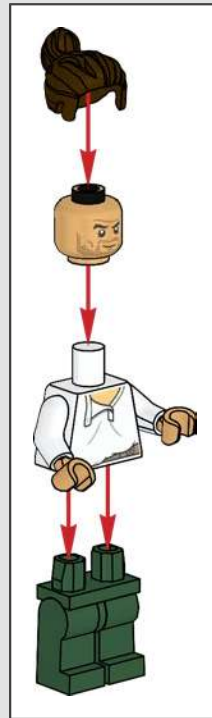
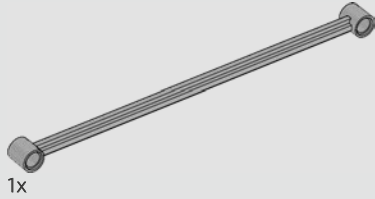
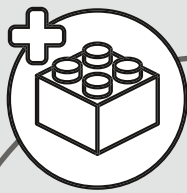

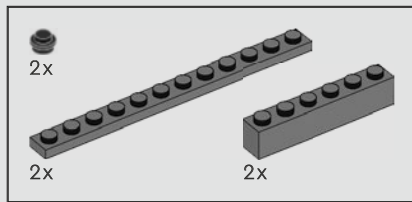

98

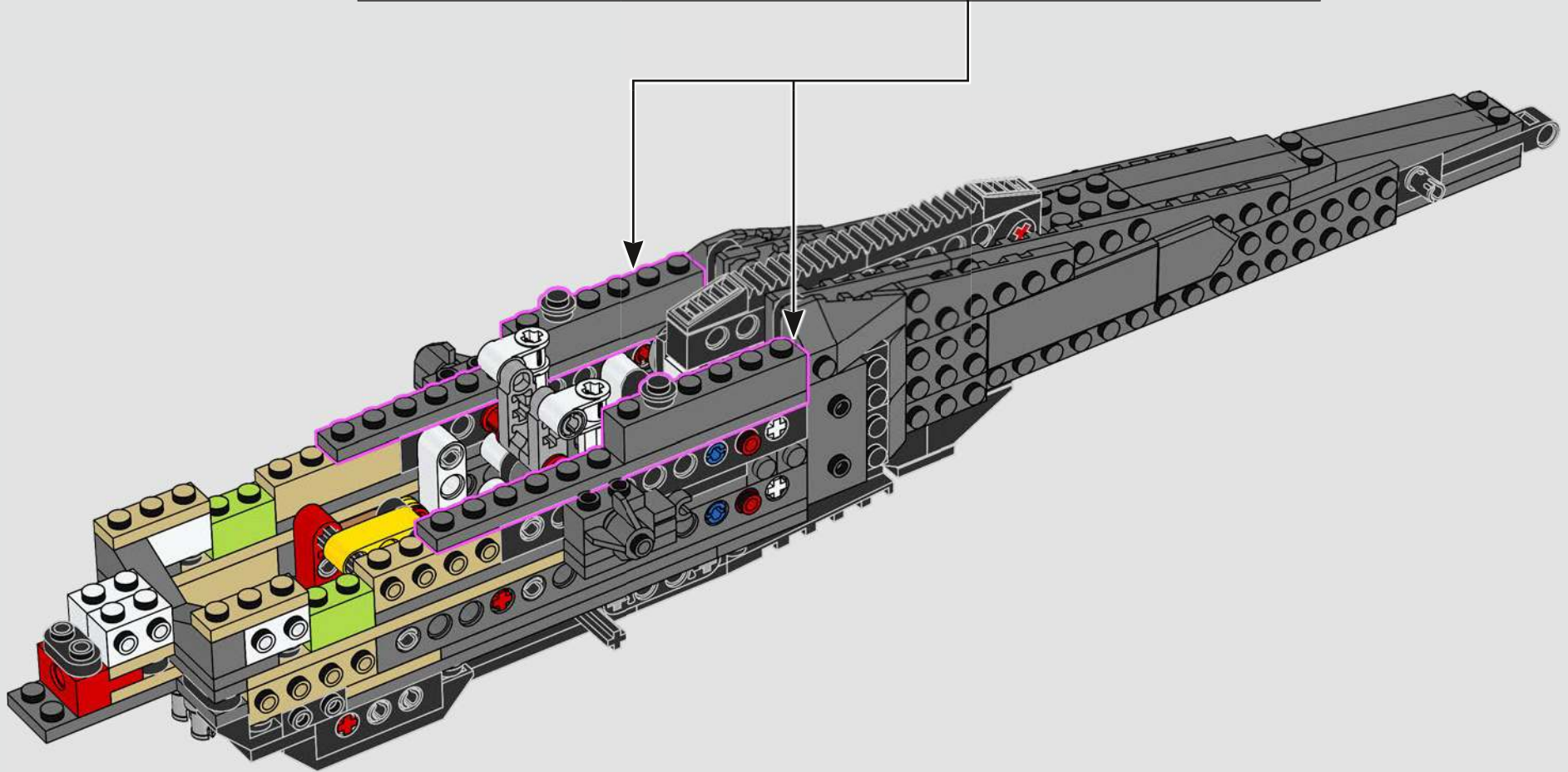
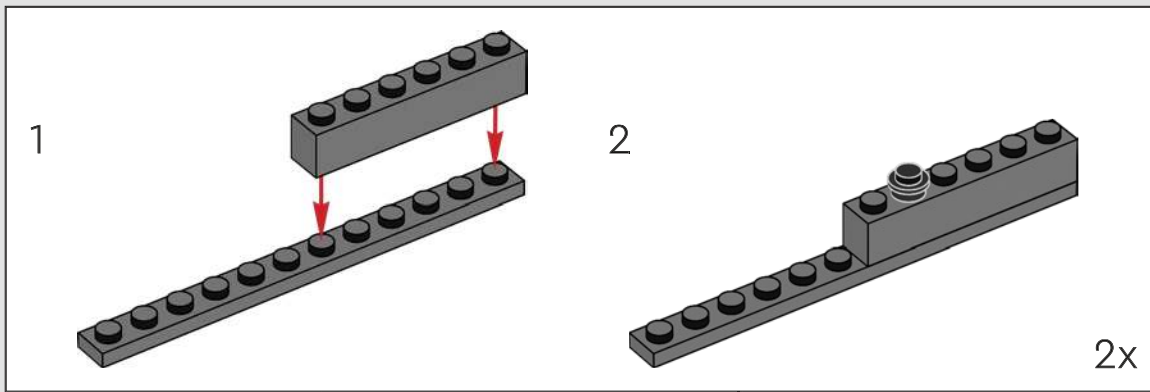

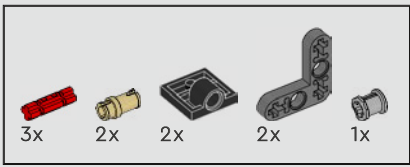

99

1



2

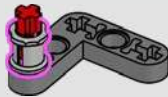

3

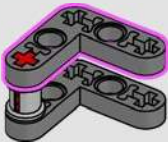

4

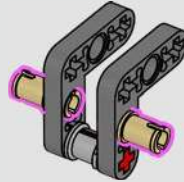
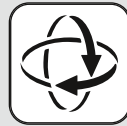

5

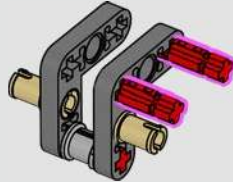

6

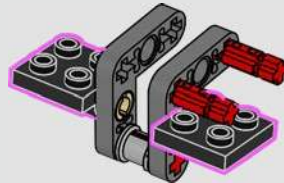

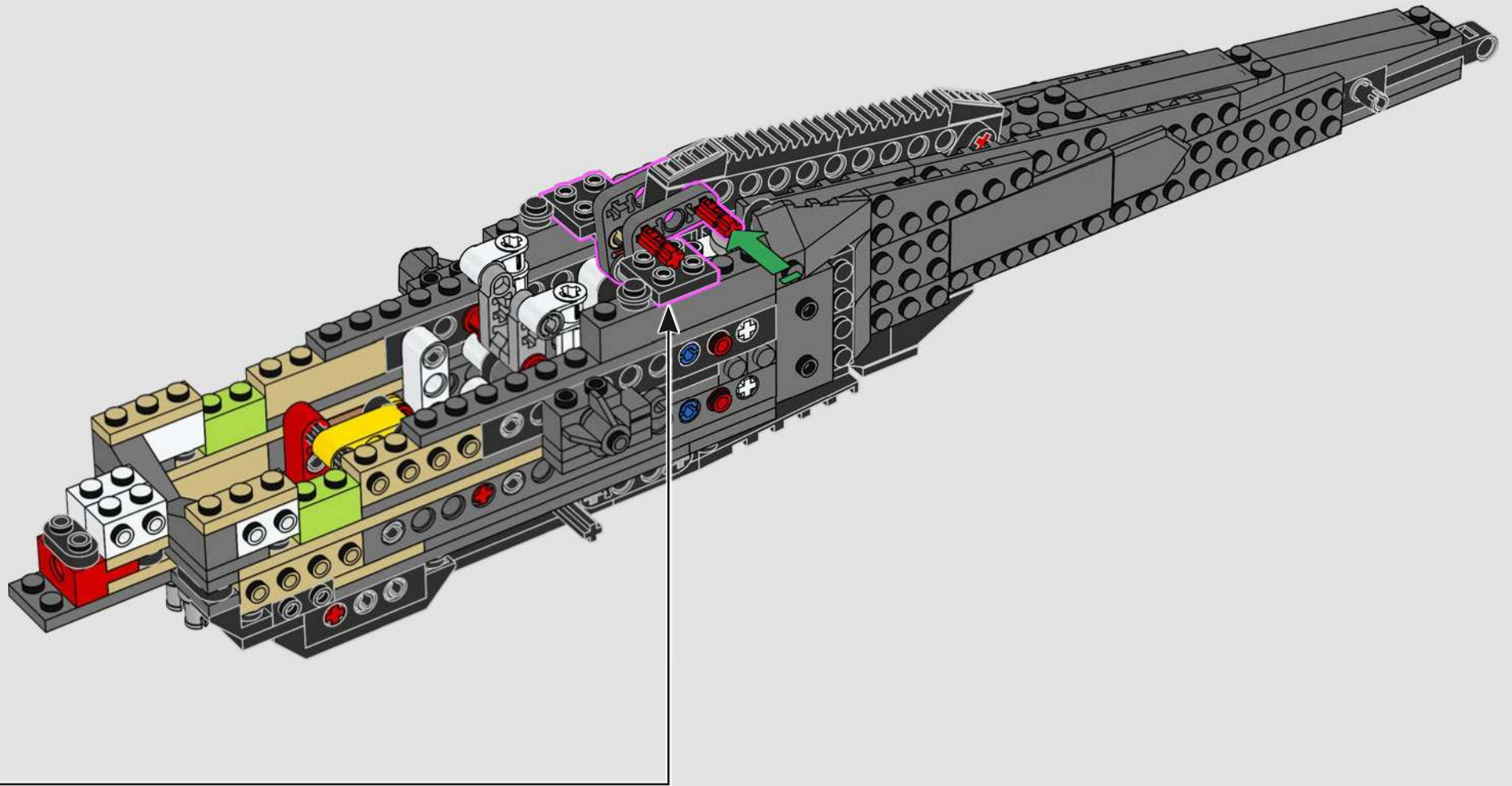

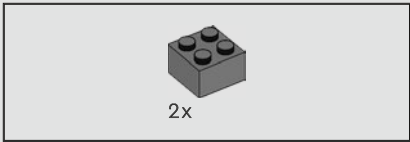

100

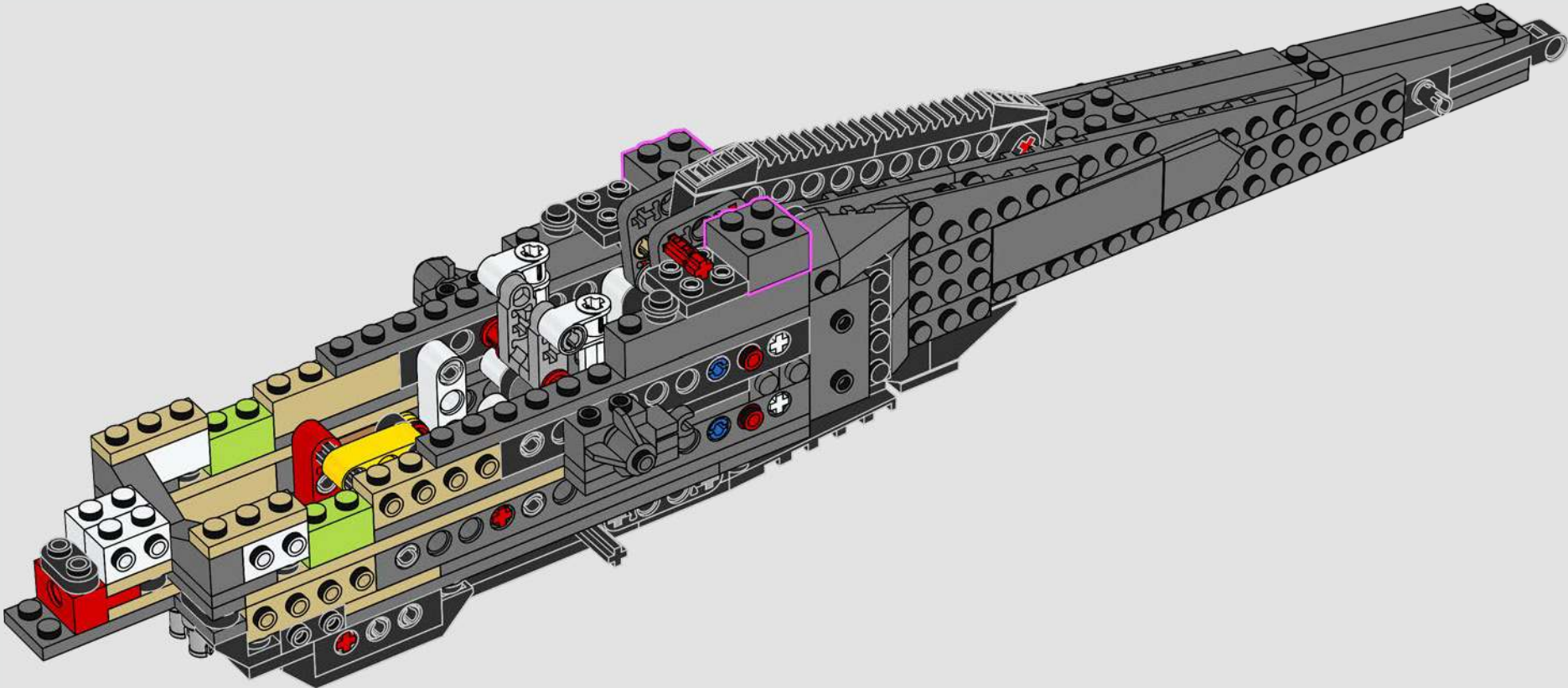

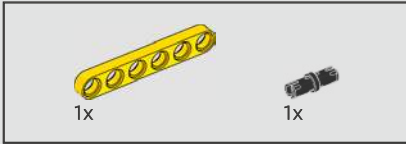
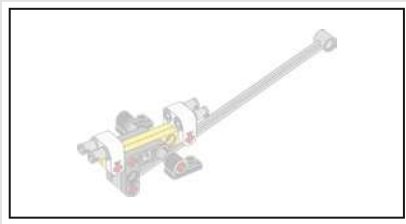

101

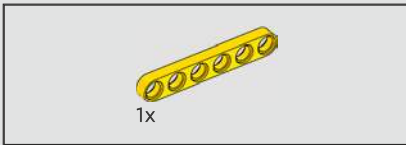
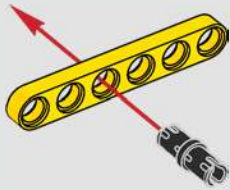

102

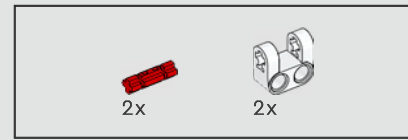
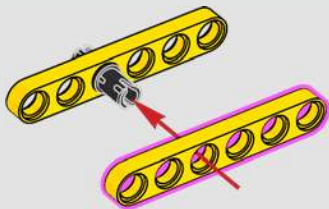

103

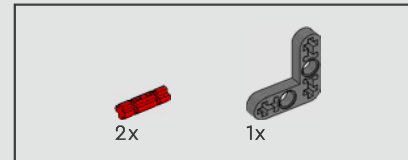
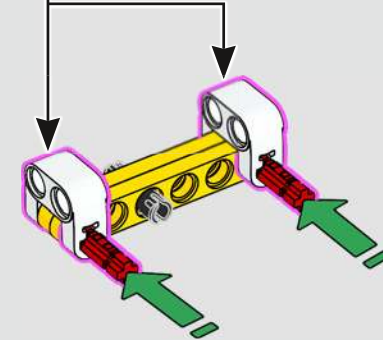
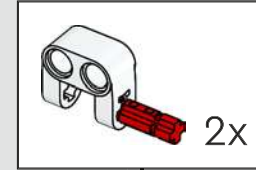

104

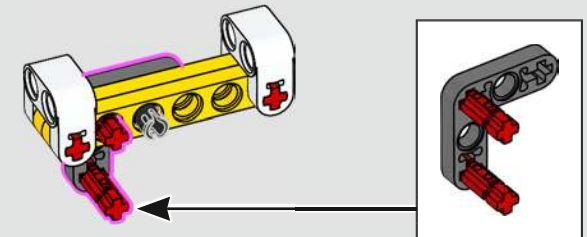

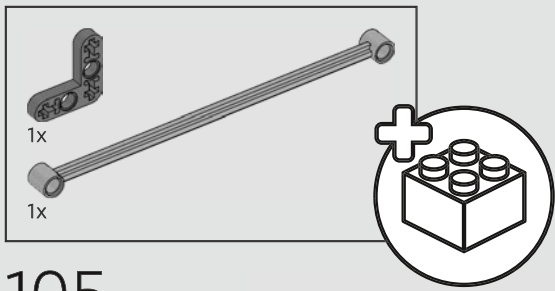

105

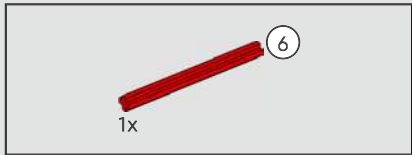
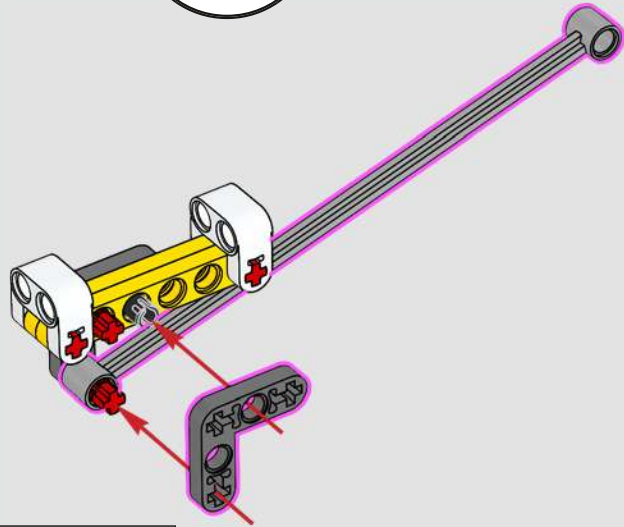

106

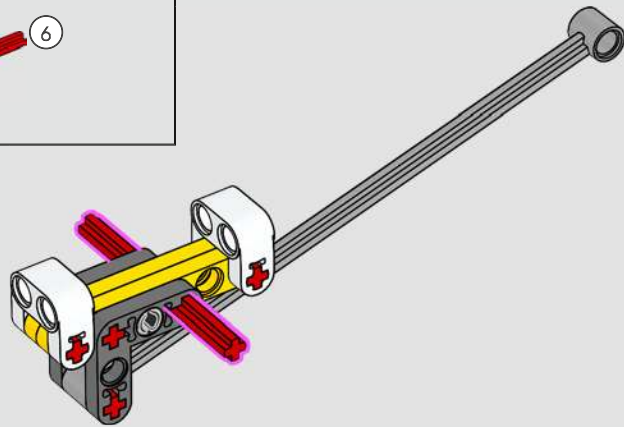

107

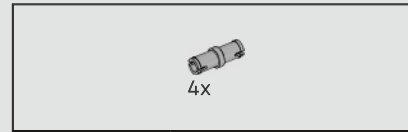
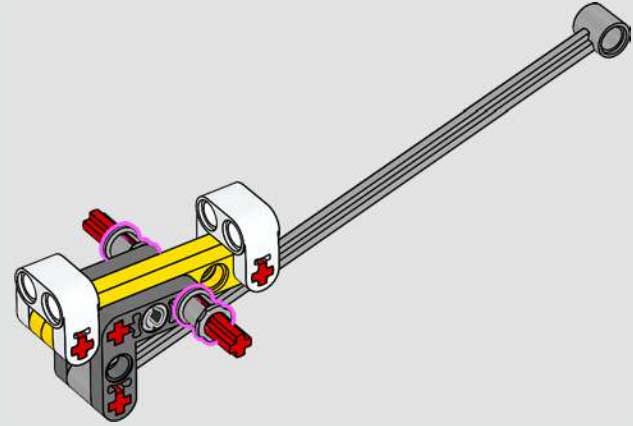

108

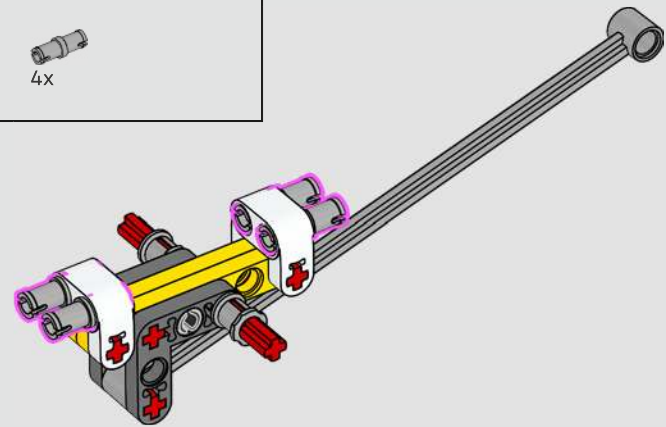



109

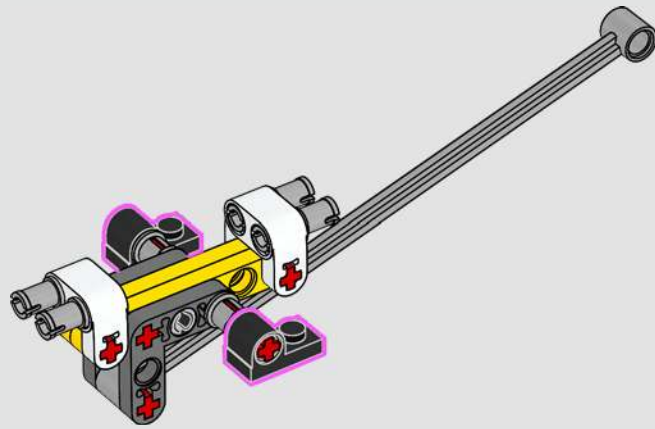

110

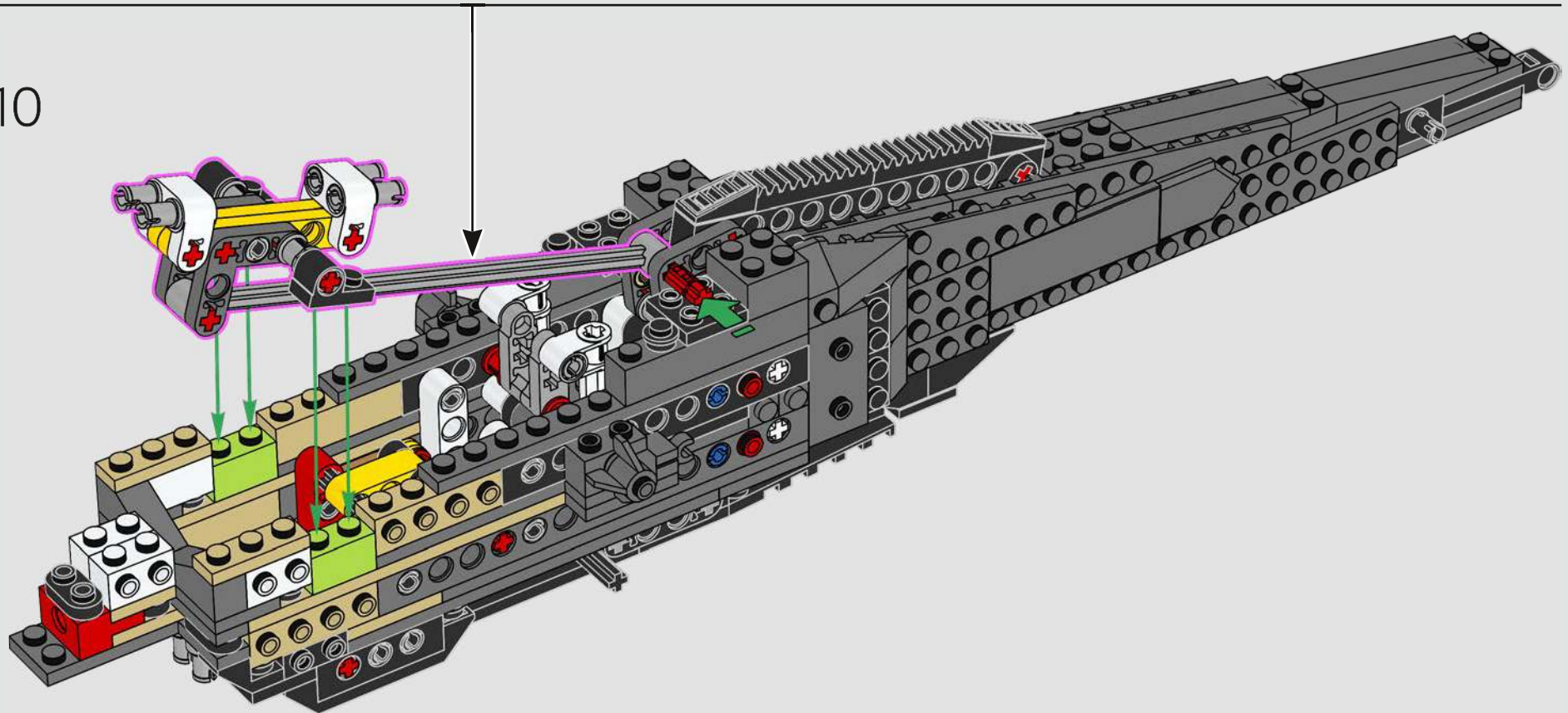

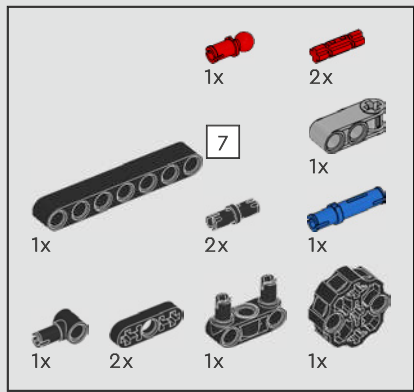

111

1



2

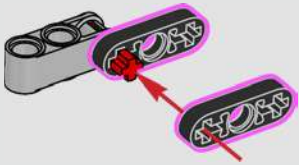

3

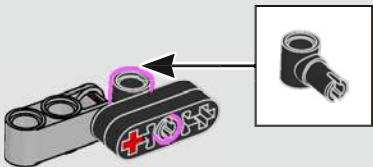

4

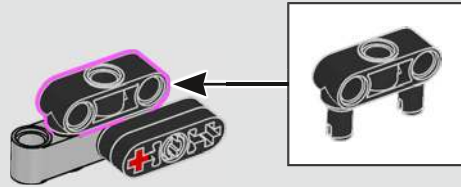

5

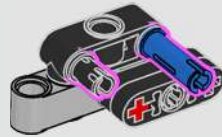

6

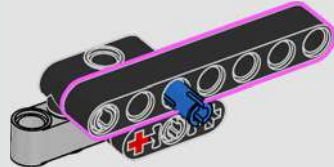

7

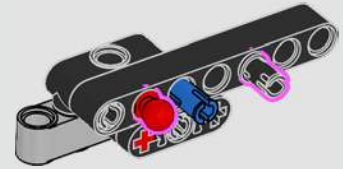

8

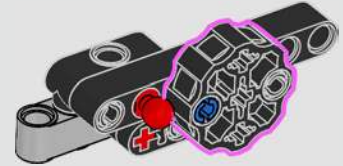

9

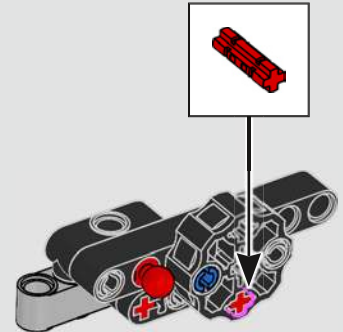



These four 'wing roots' form the foundation for the flapping mechanism of the ornithopter.

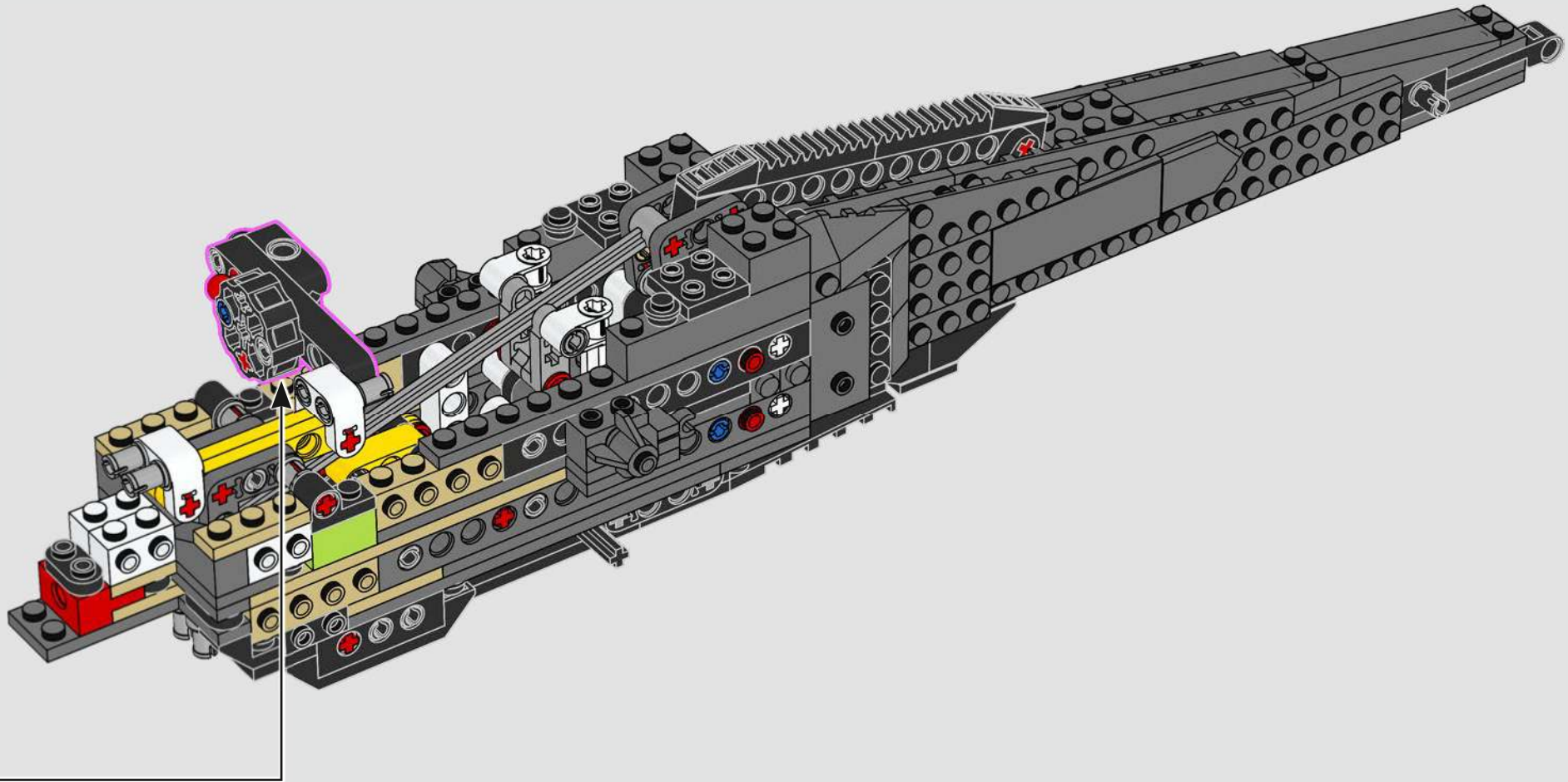

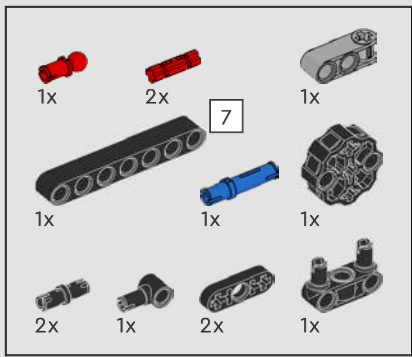

112

1



2

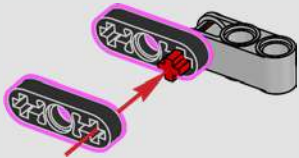

3

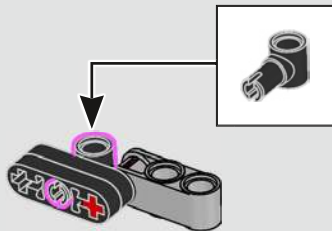

4

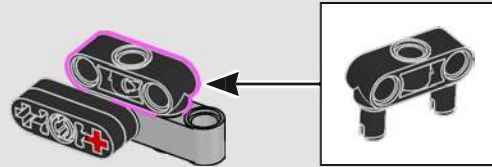

5



6

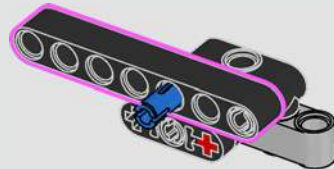

7

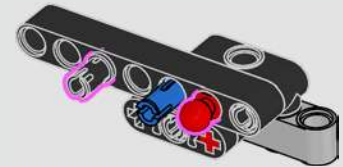

8

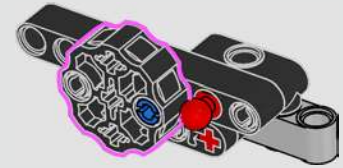

9

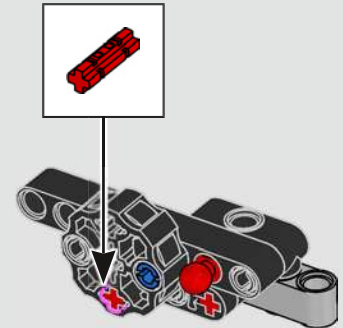

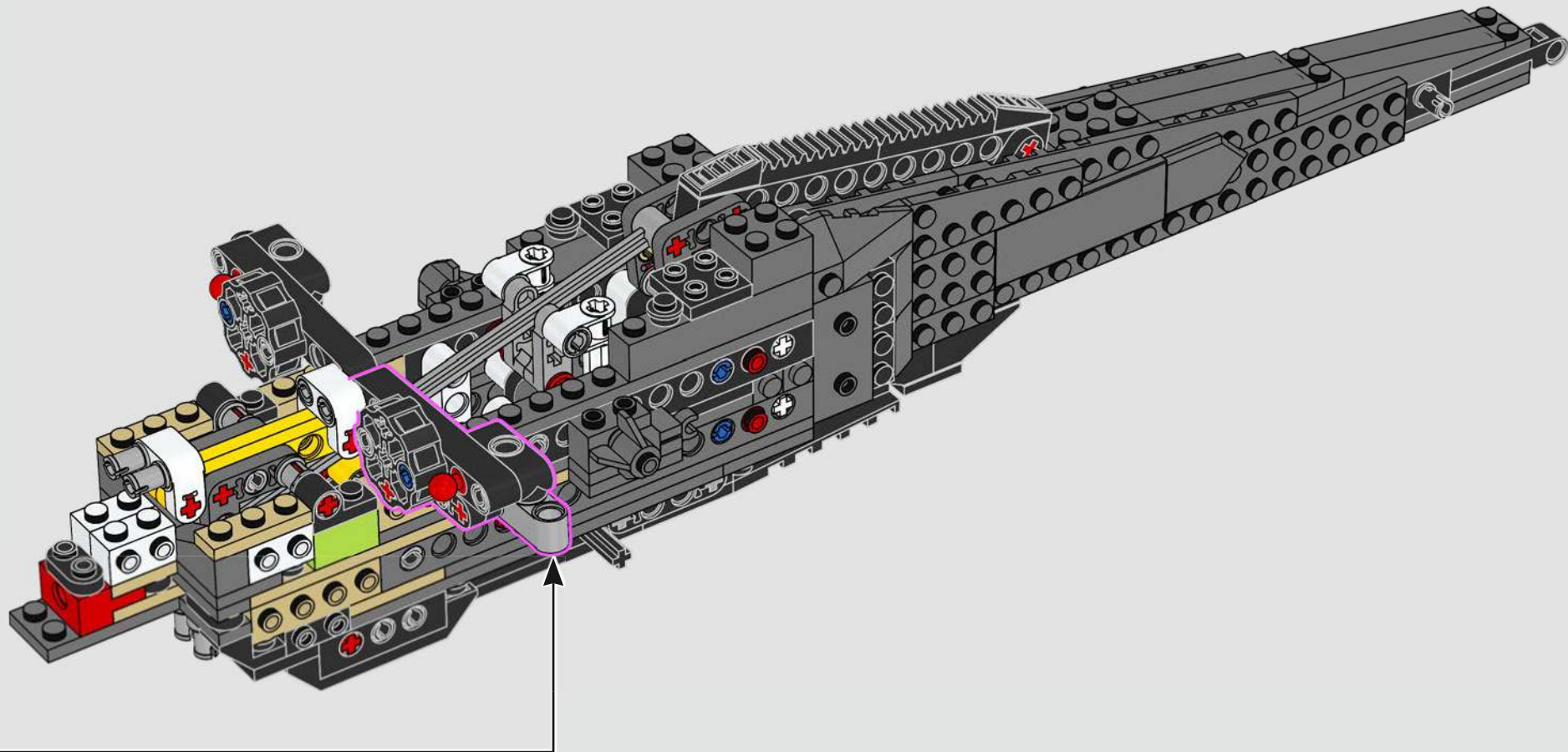

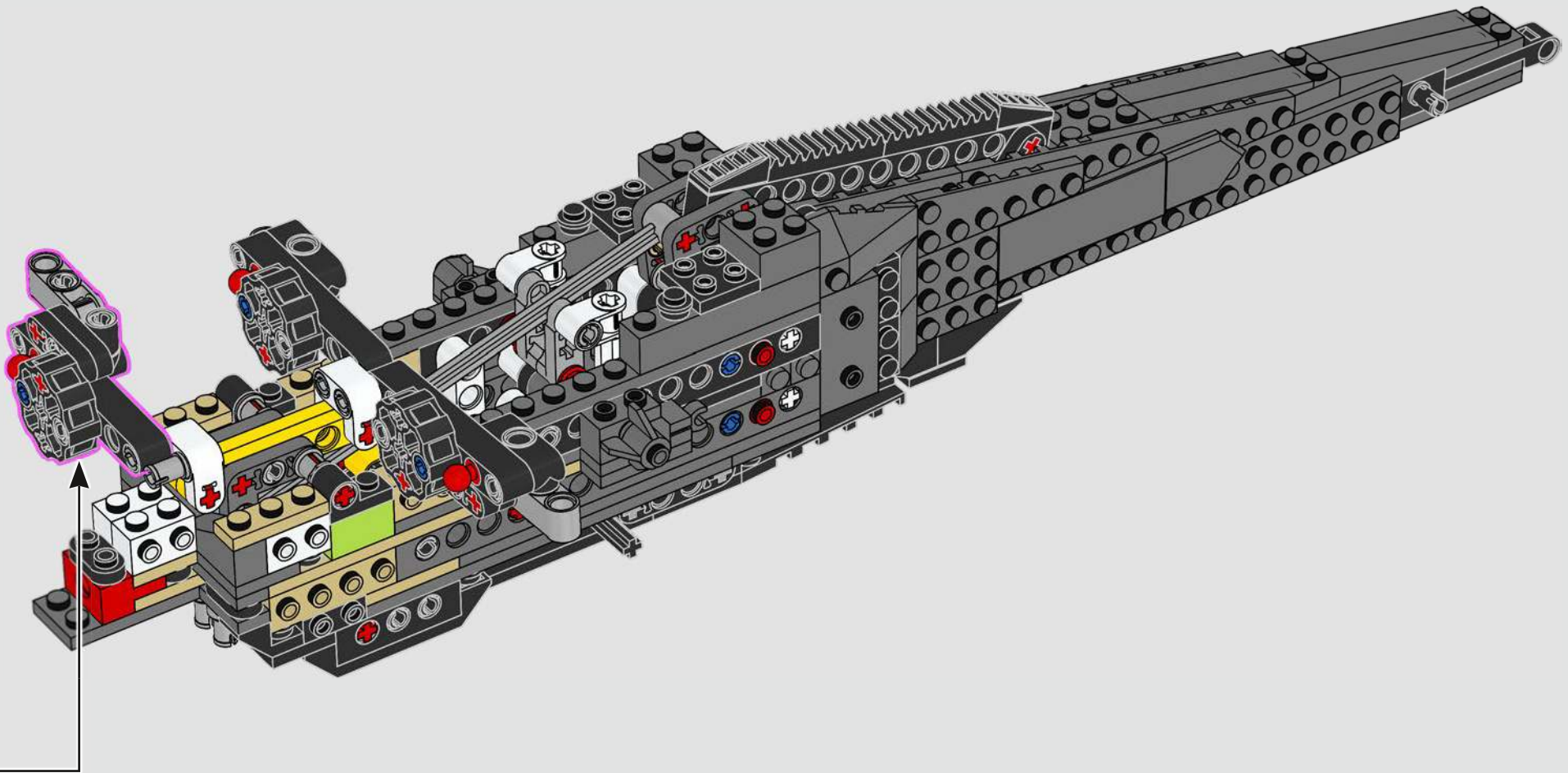

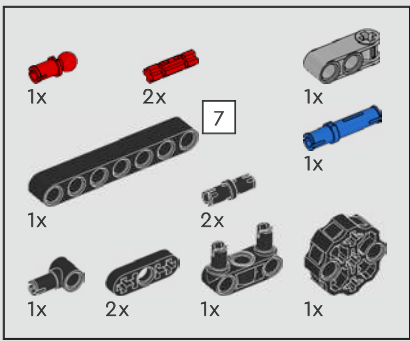

114

1



2

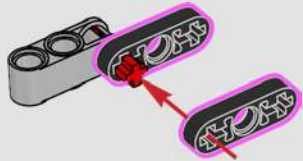

3

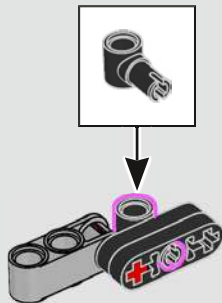

4

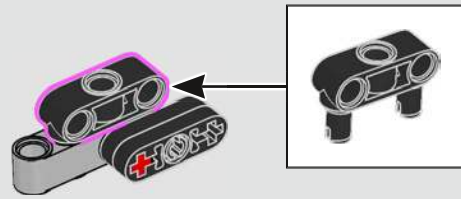

5



6

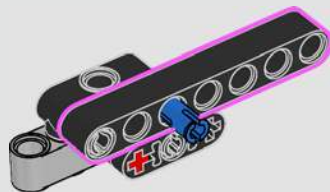

7

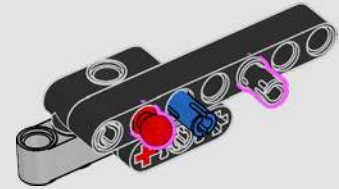

8

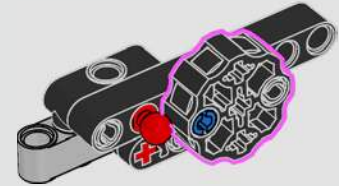

9

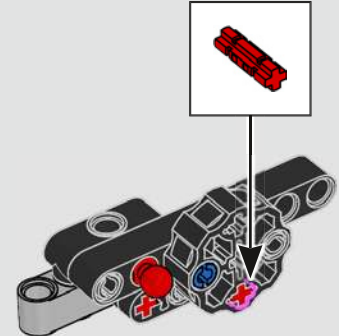

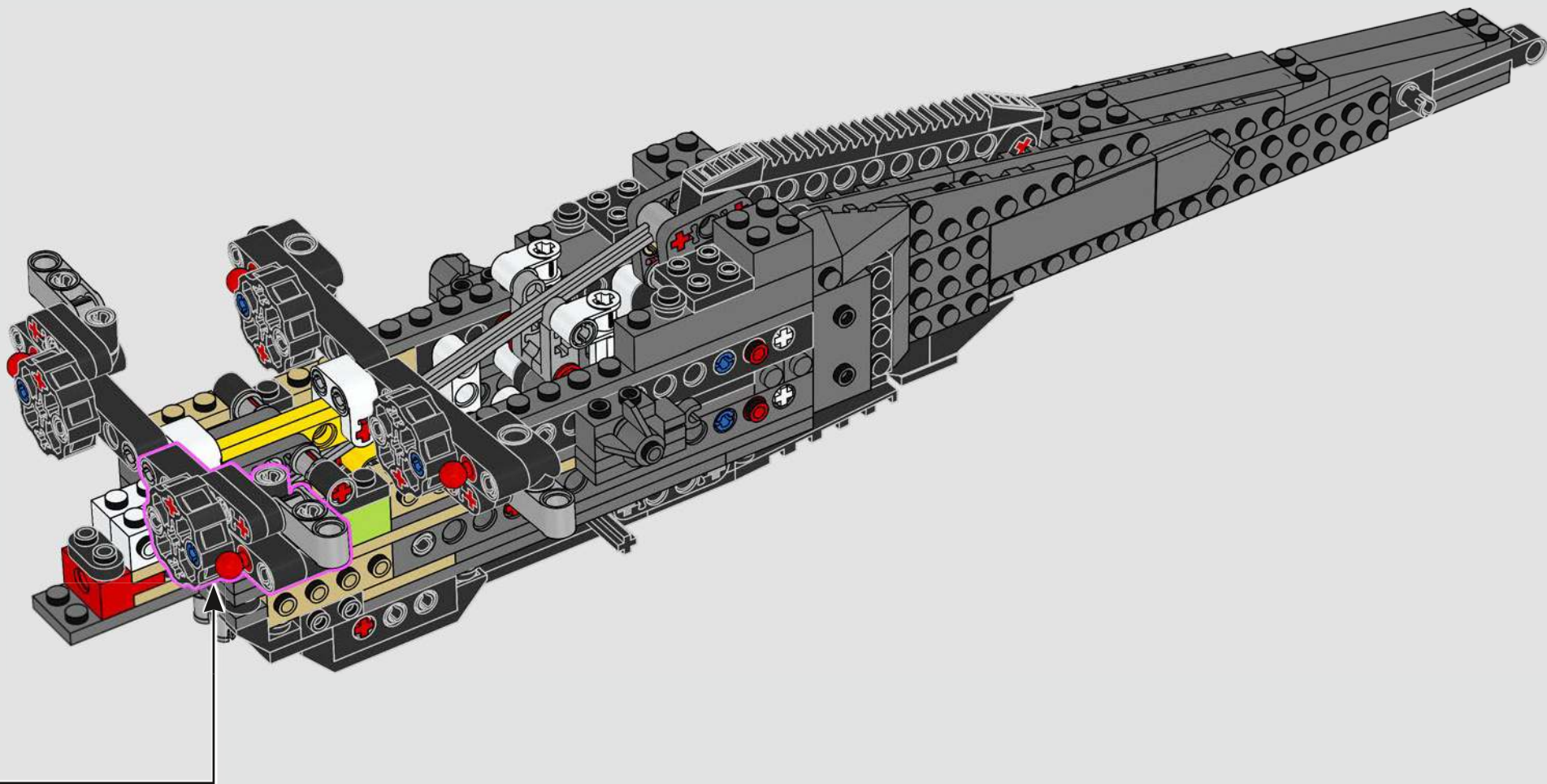

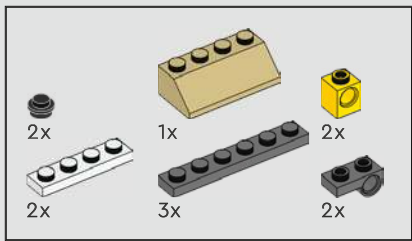

115

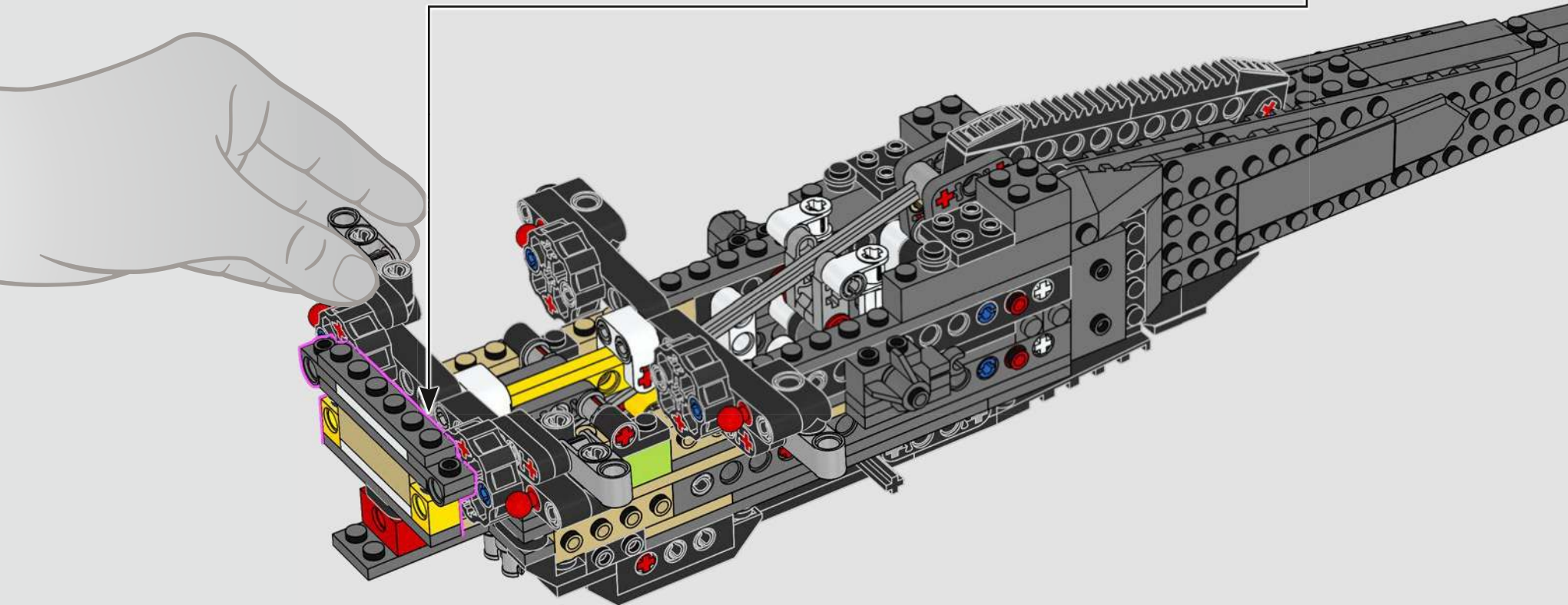
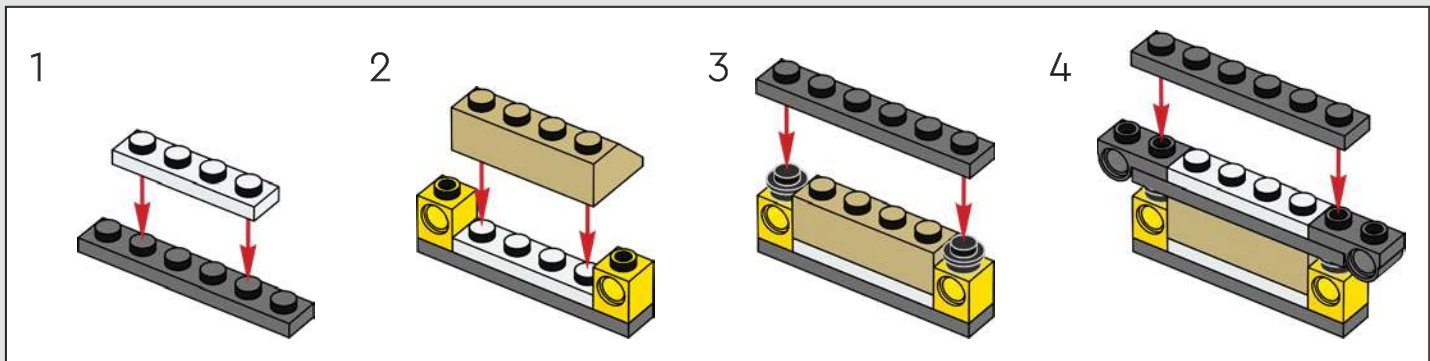

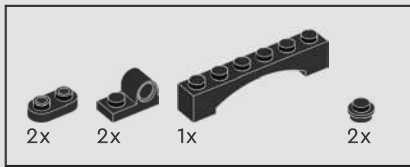

116

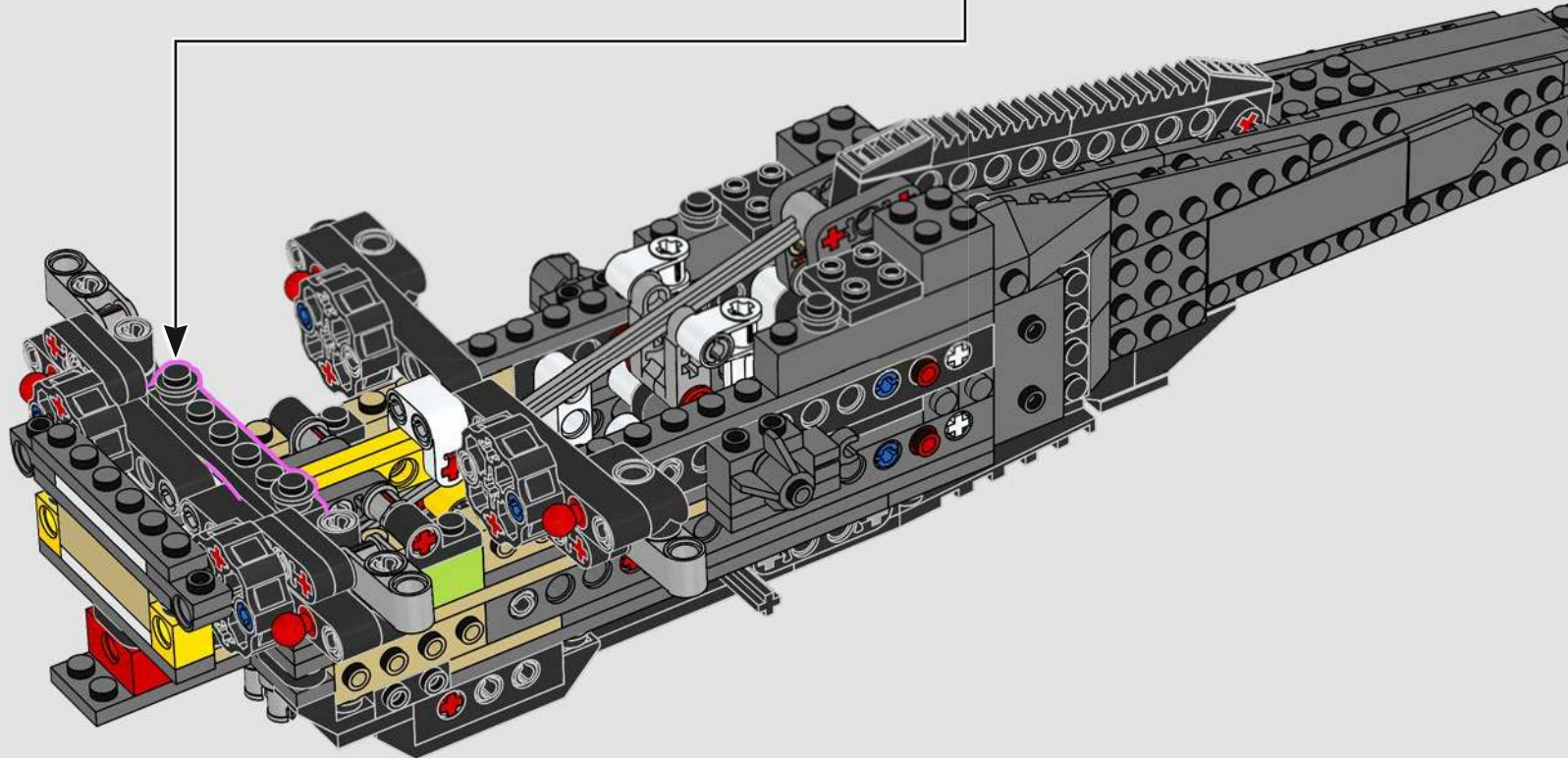
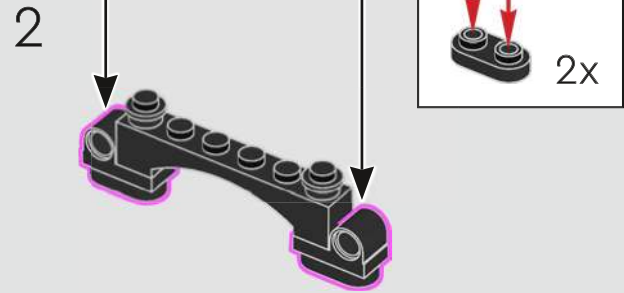
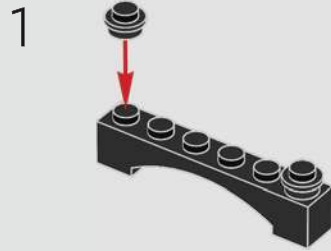

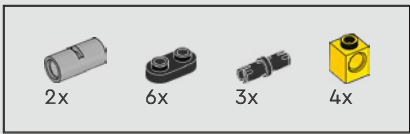

117

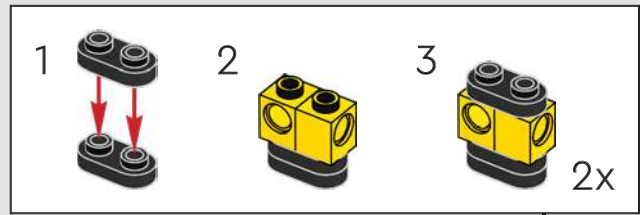

1

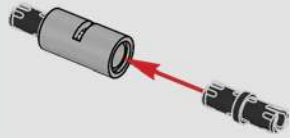

2

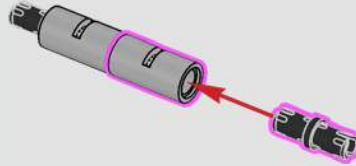

3

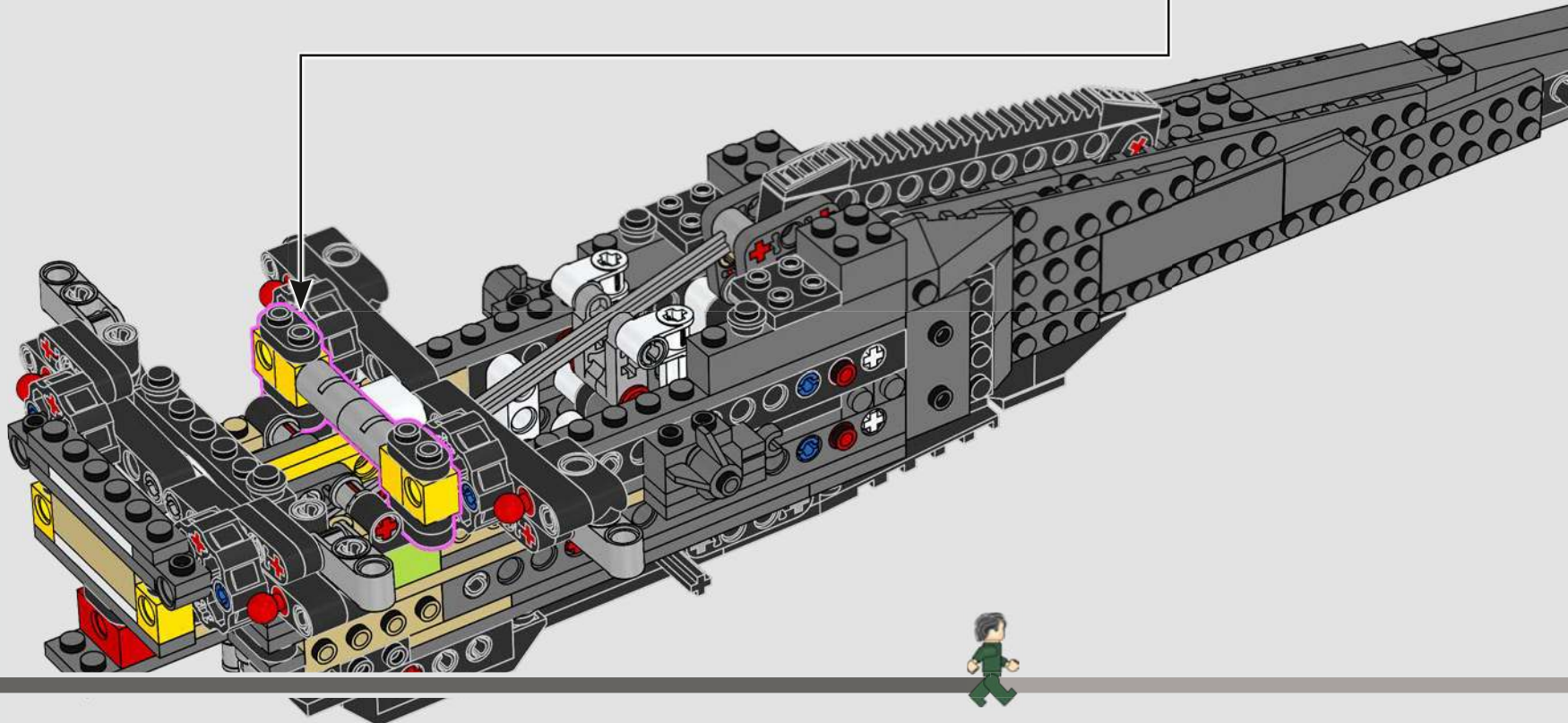
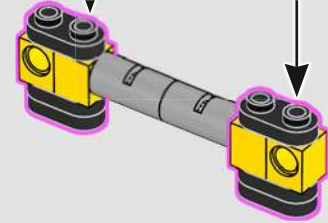

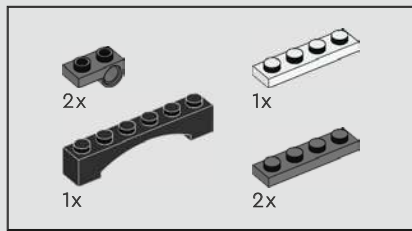

118

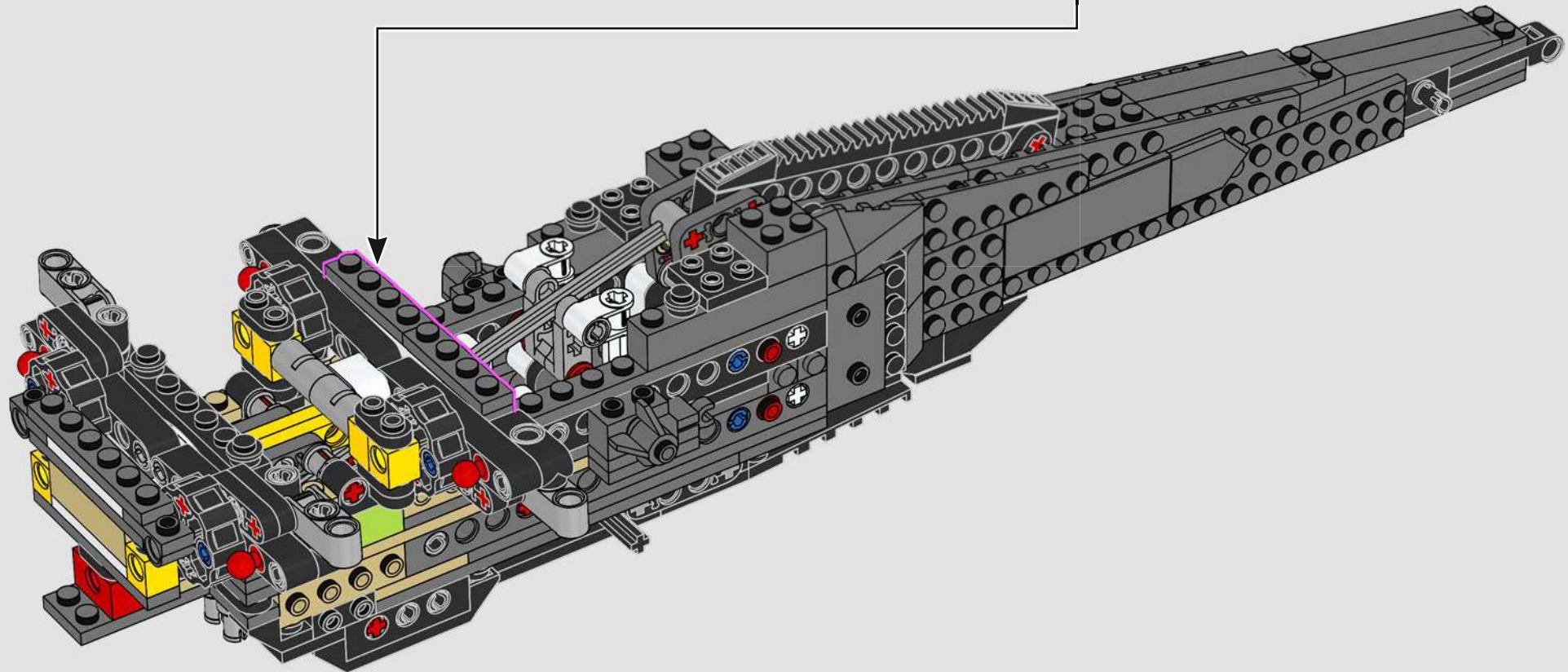
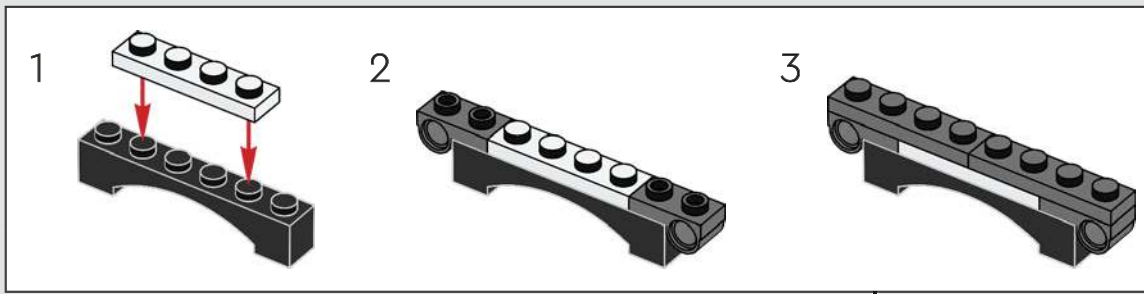

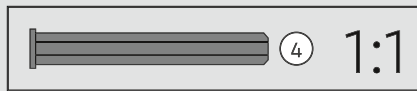
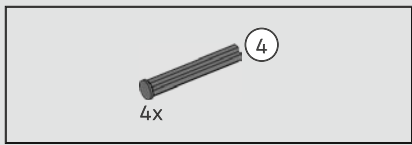

119

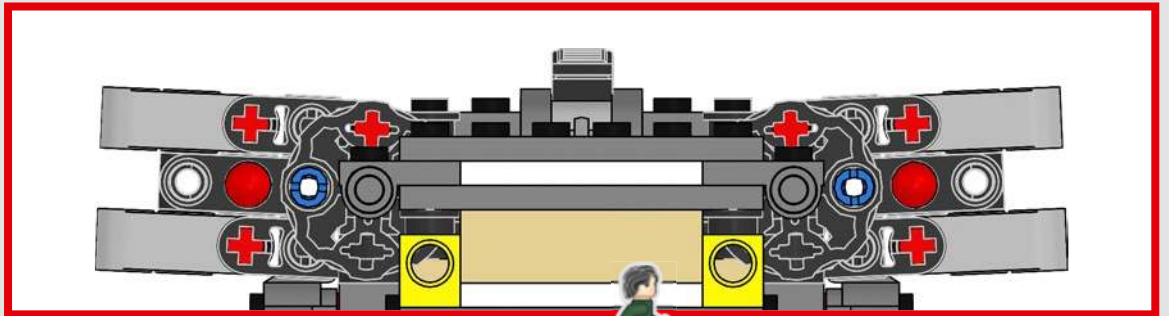
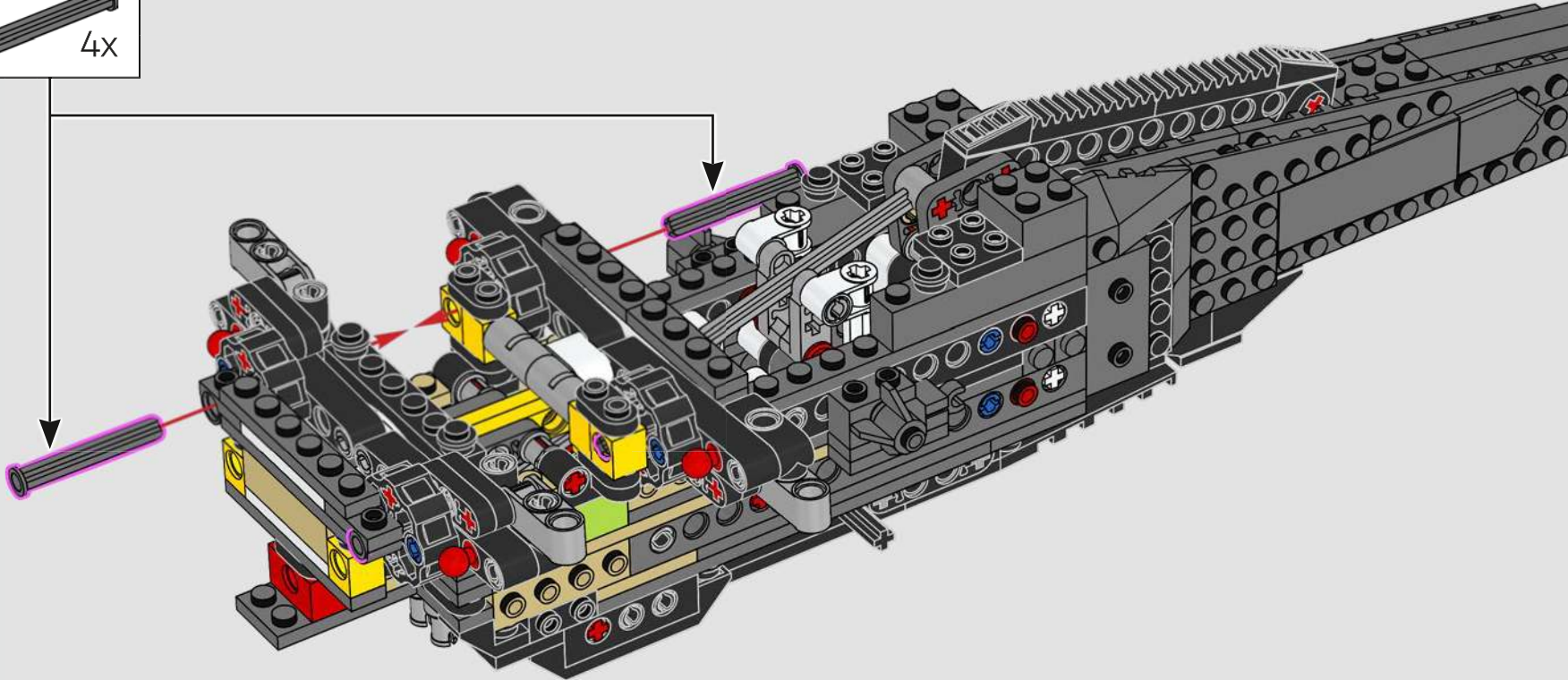
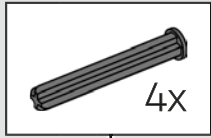

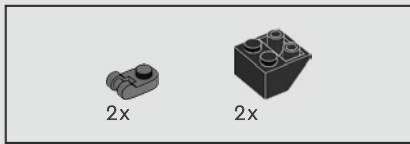

120

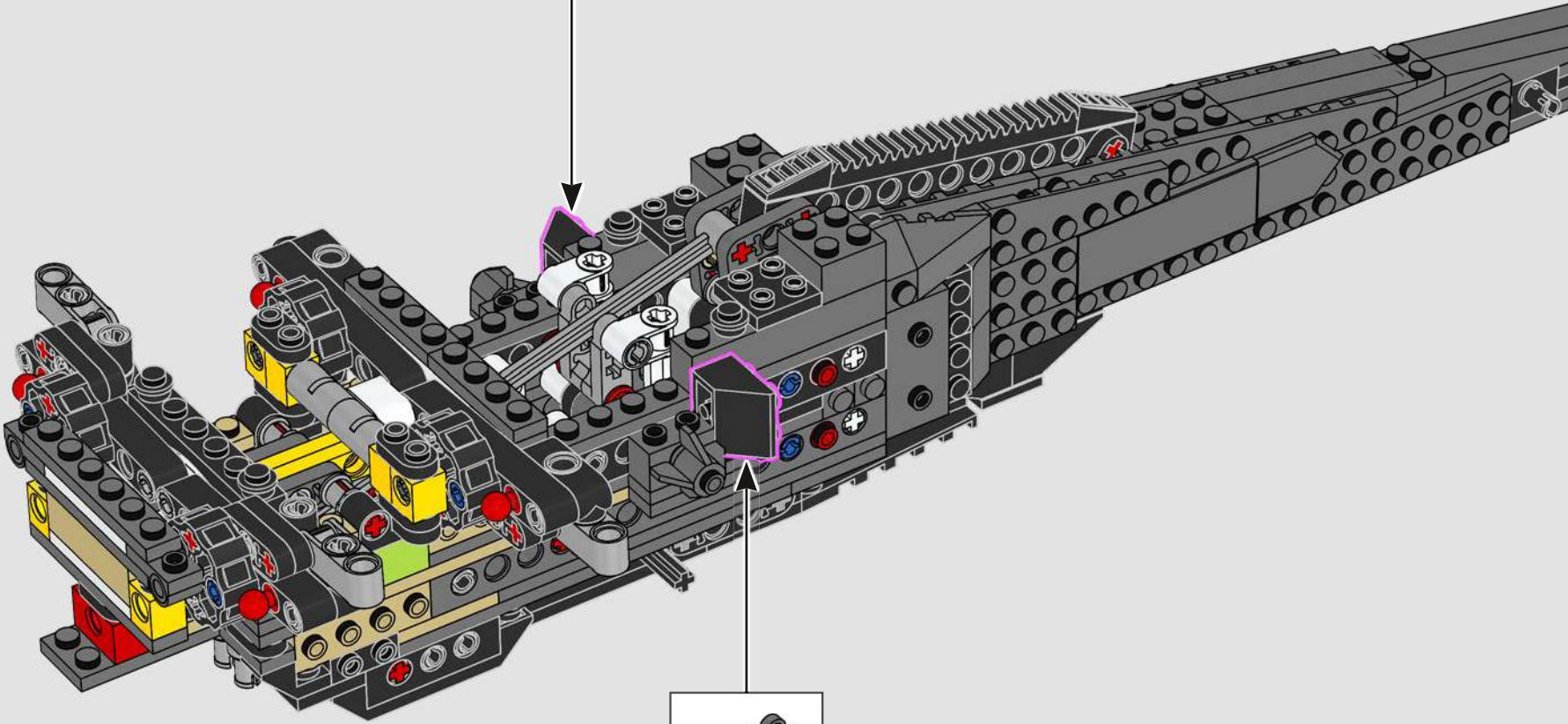
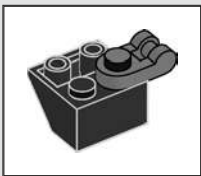

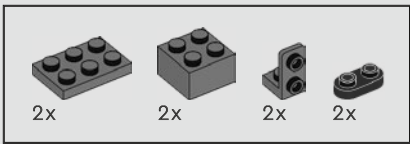

121

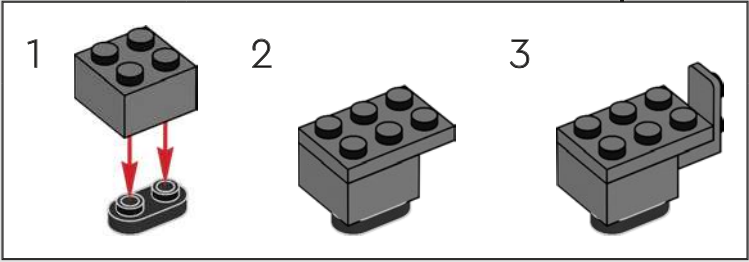
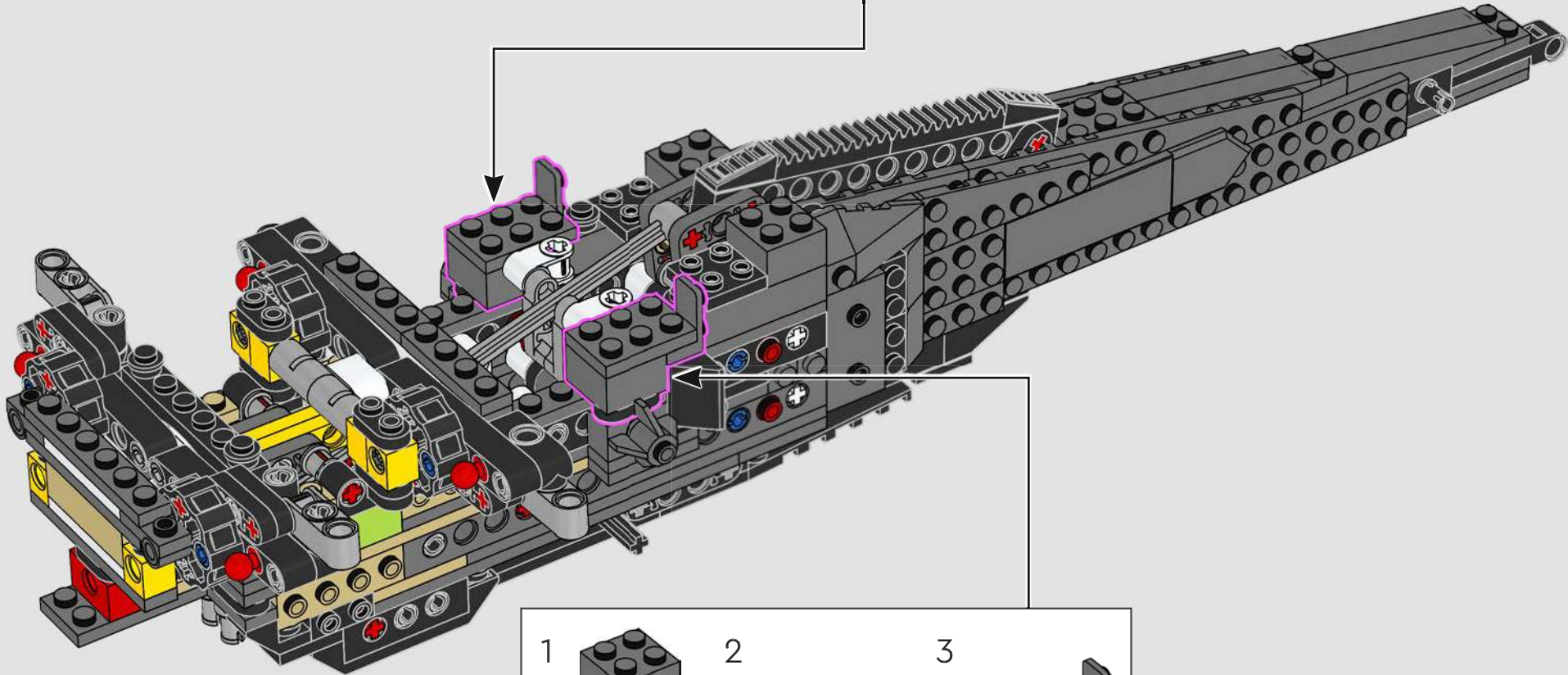
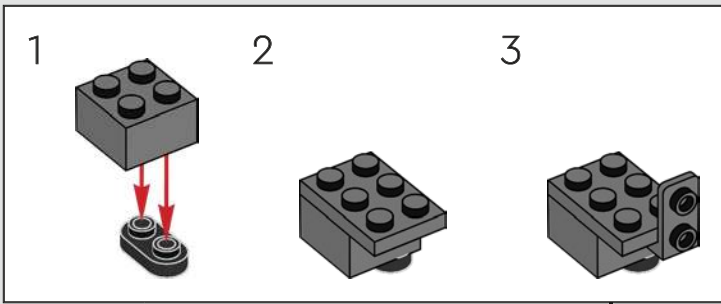

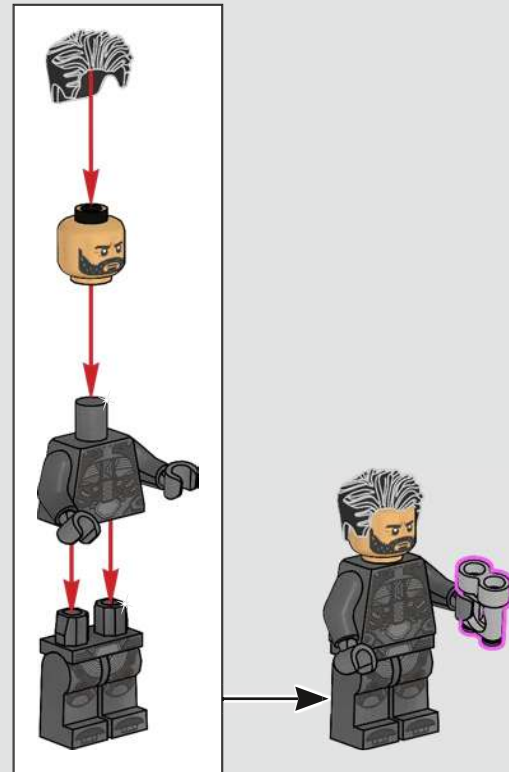



122

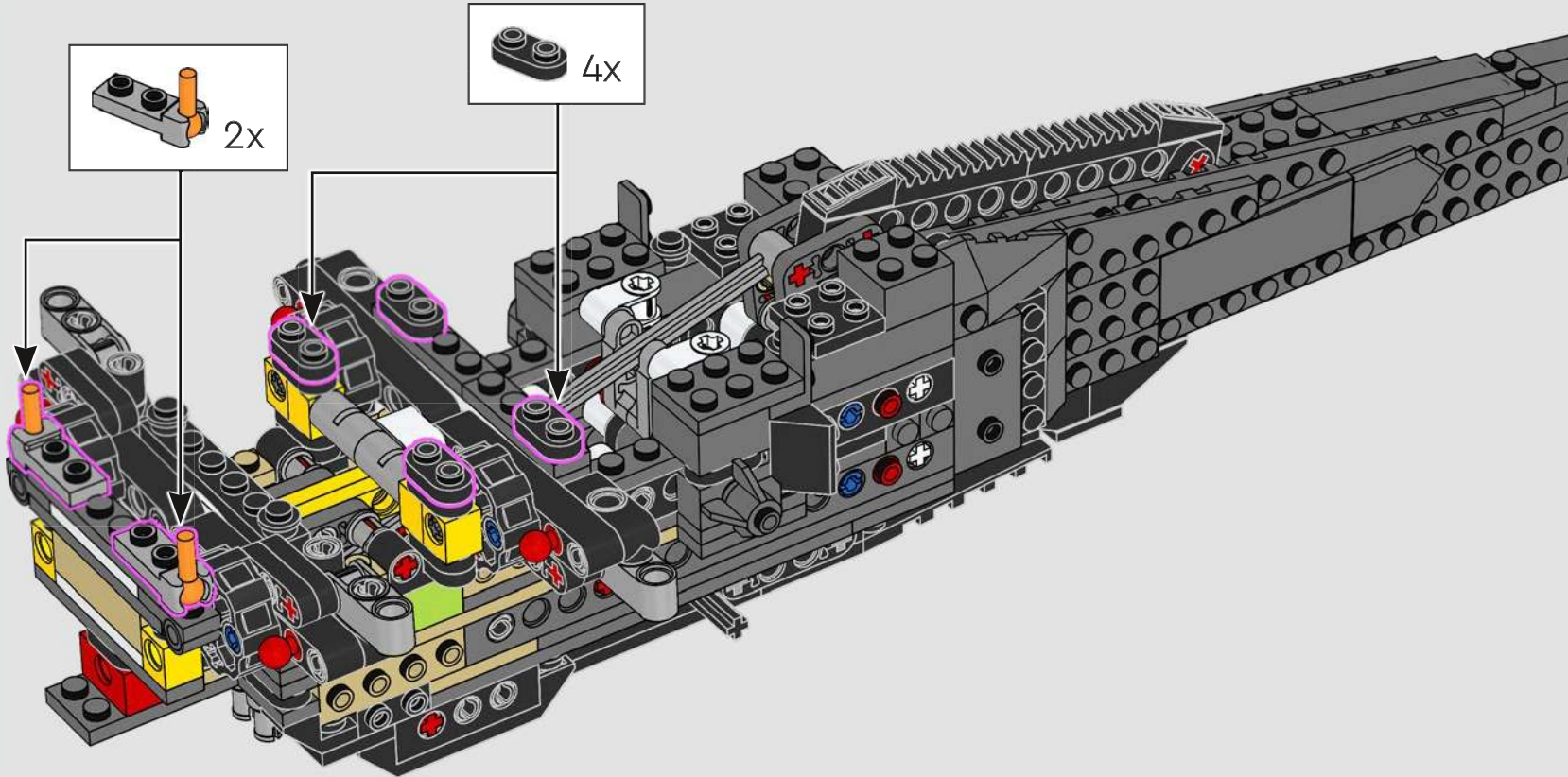



Activating this lever will extend and retract the wings of the craft.

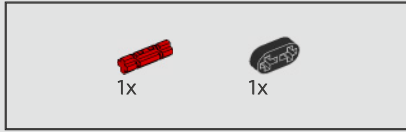
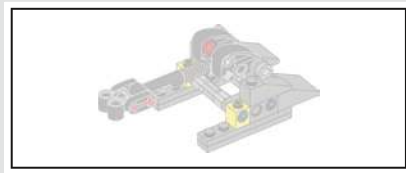

123

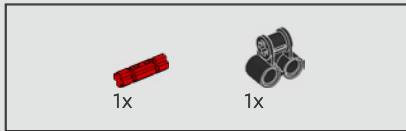

124

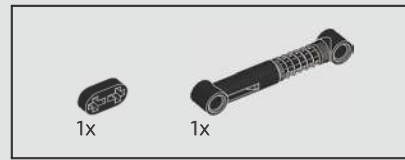

125

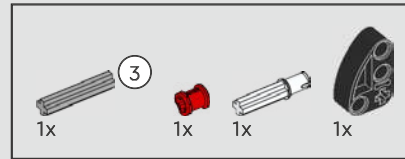

126

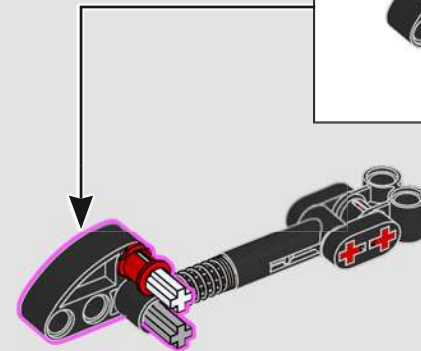
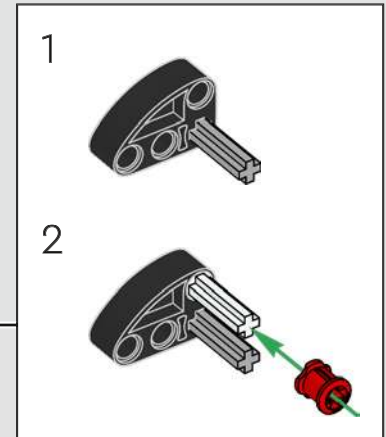
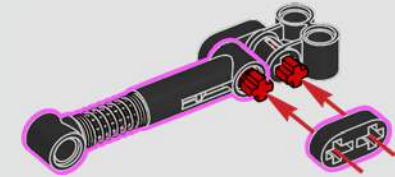
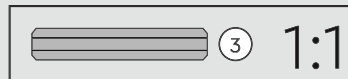



127

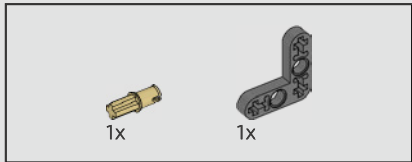
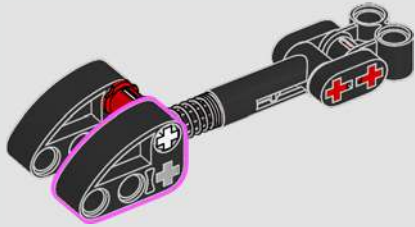

128

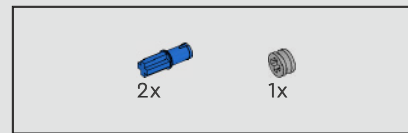
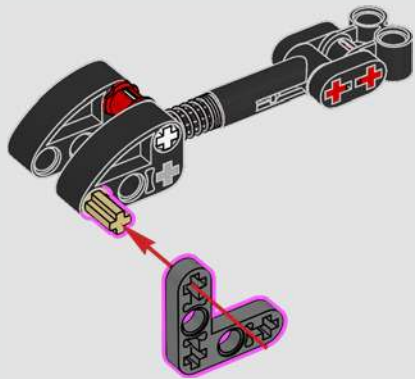

129

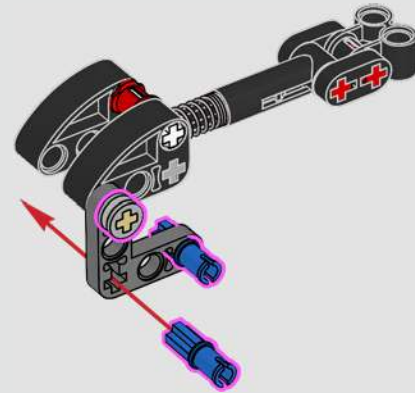

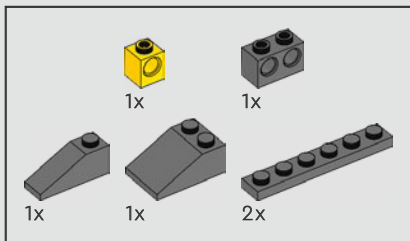

130

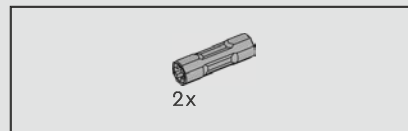
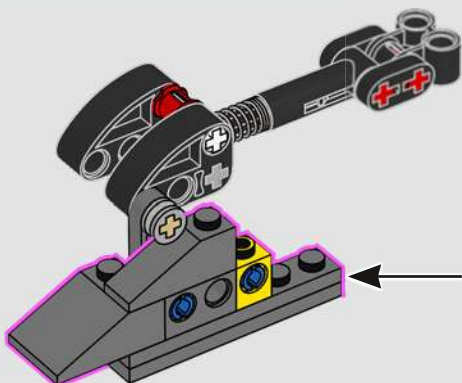
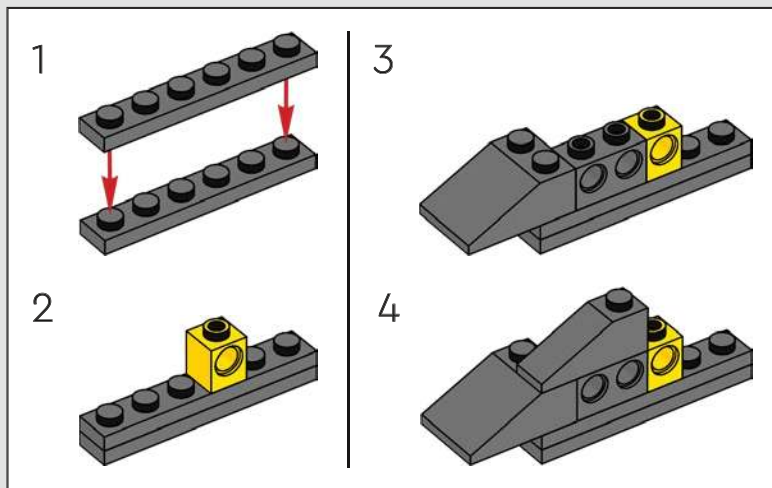

131

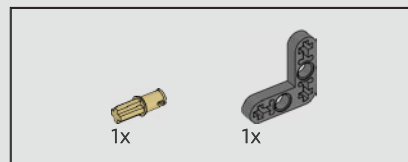
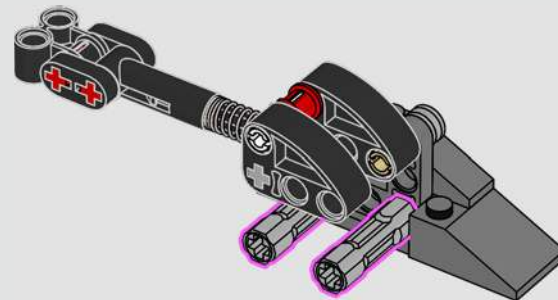

132

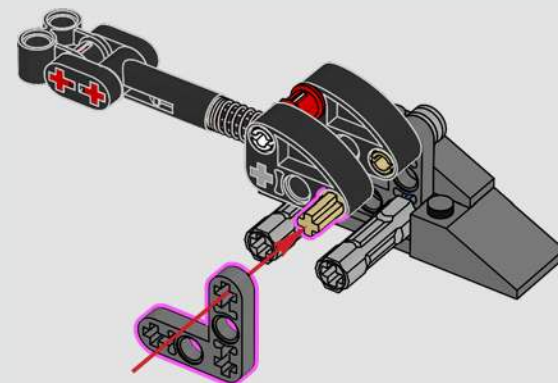

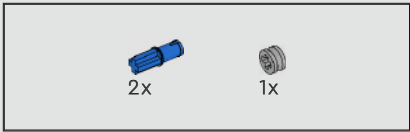

133

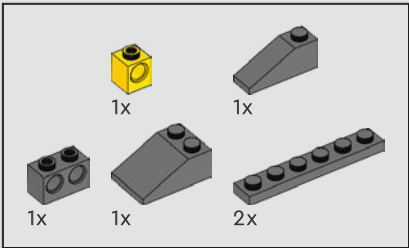
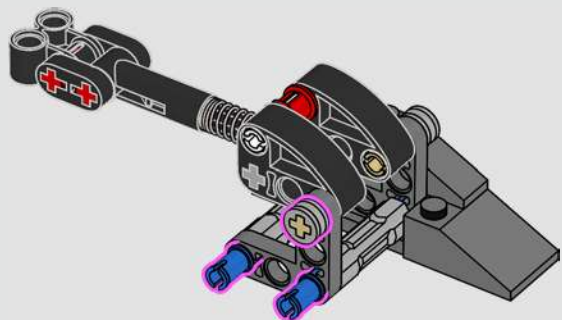

134

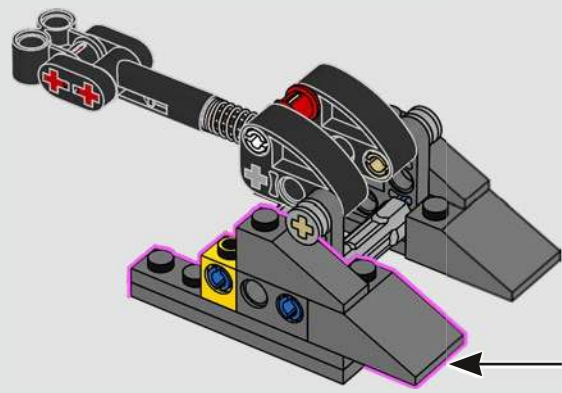
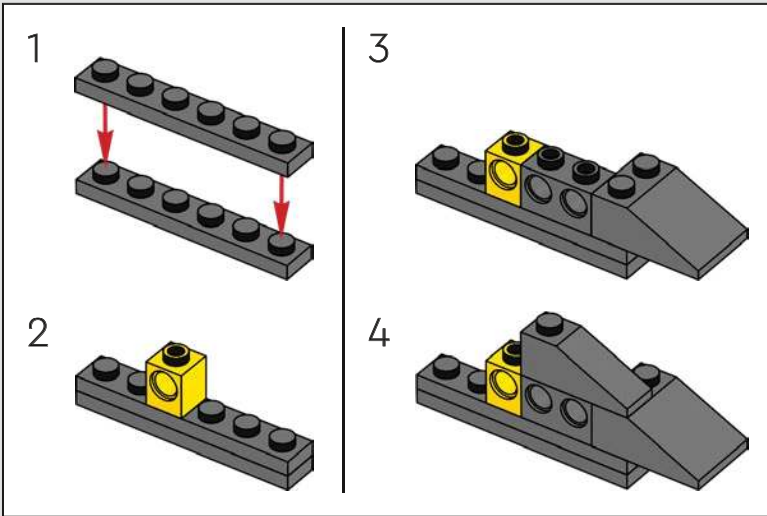

135

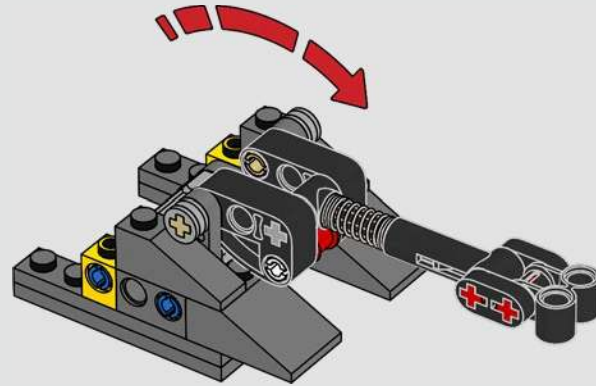

136

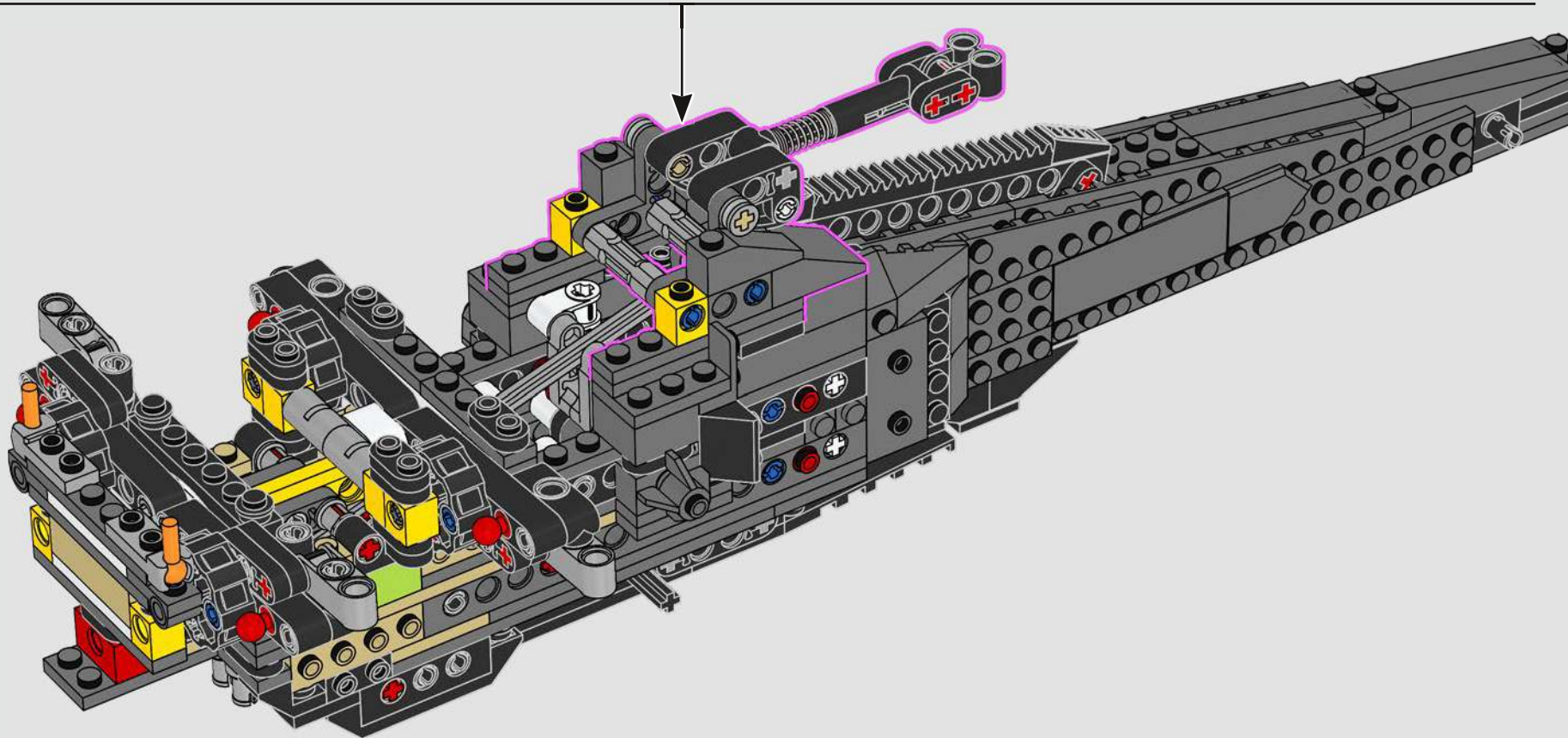

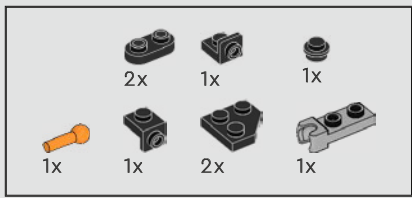

137

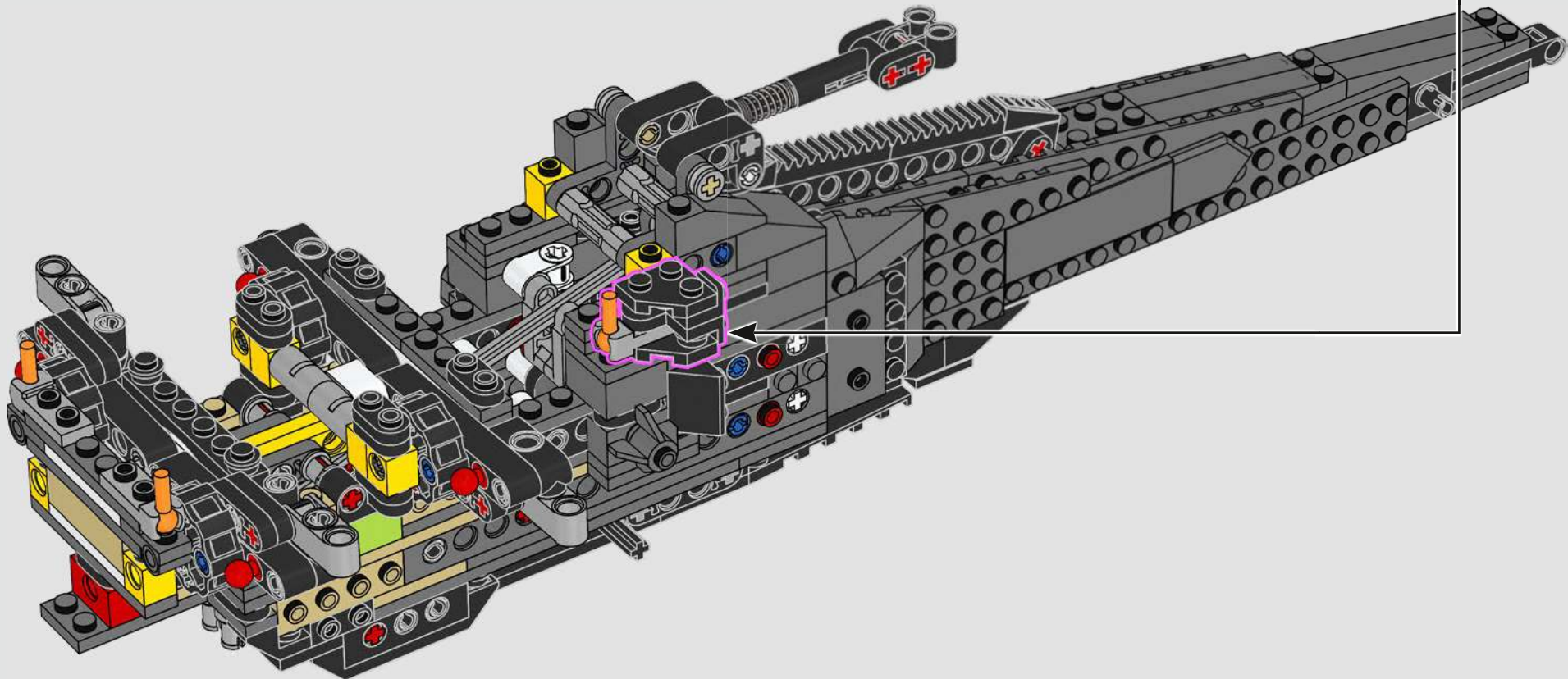
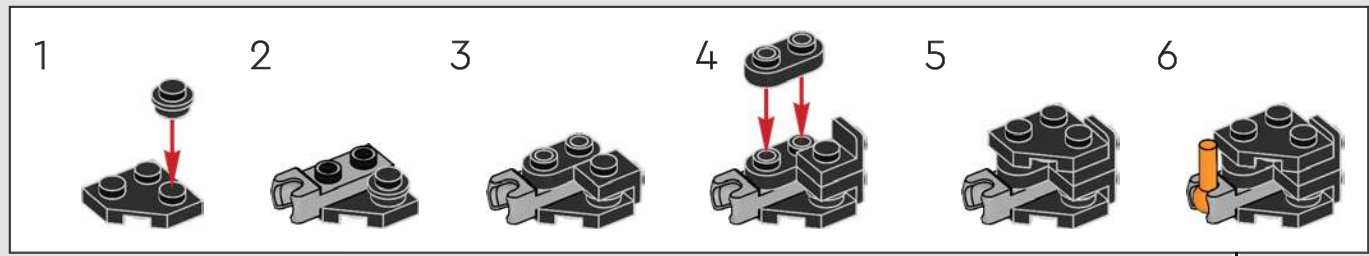

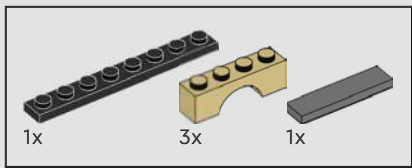

139

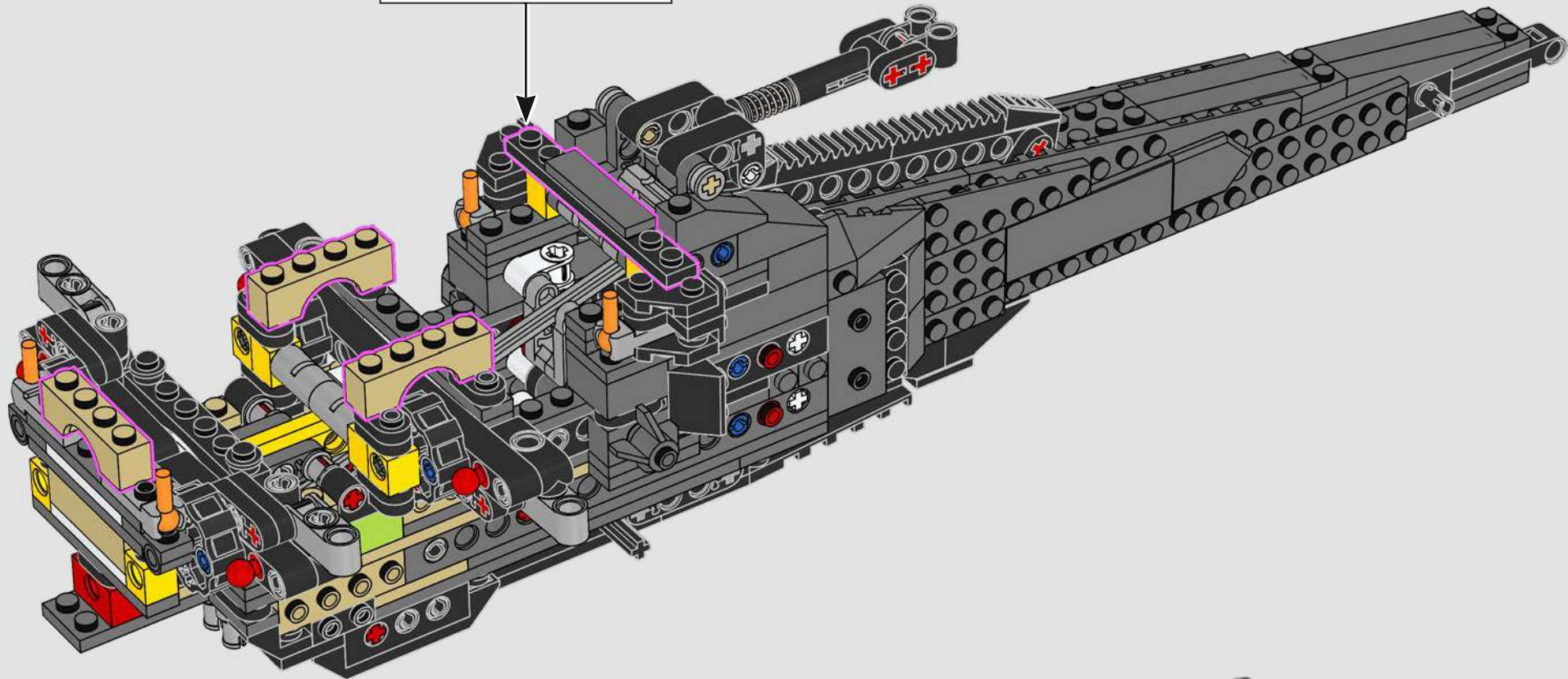
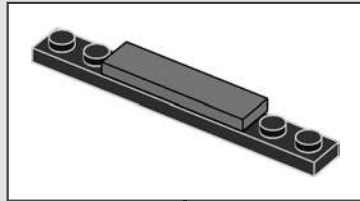

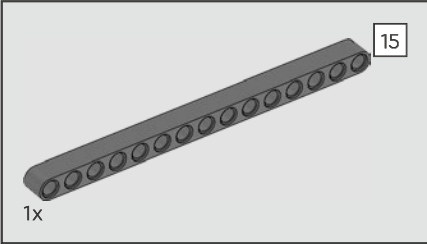
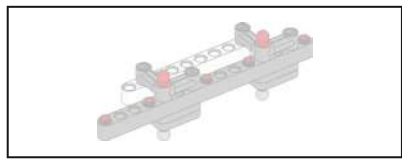

140

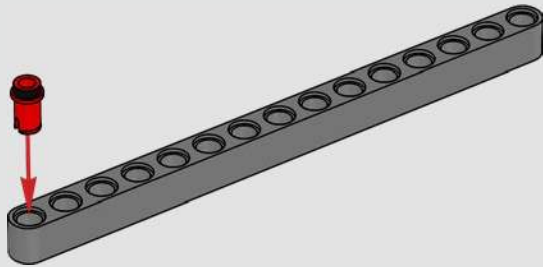

141

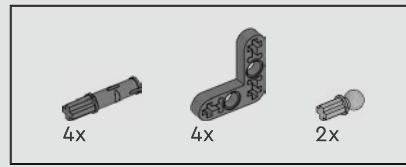
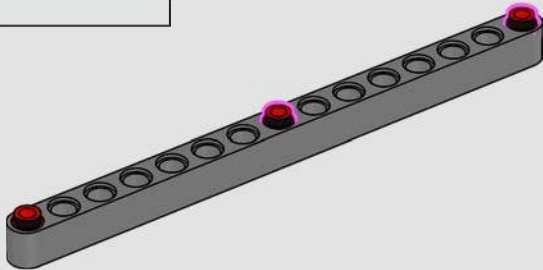

142

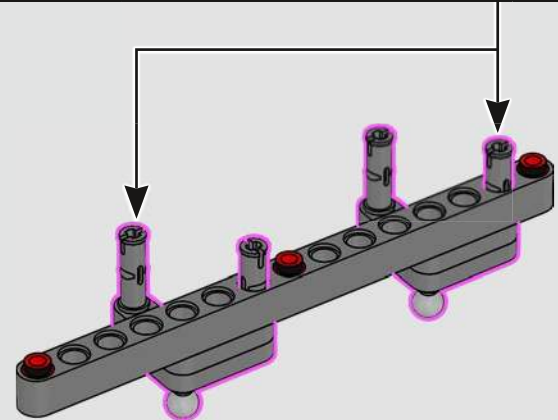
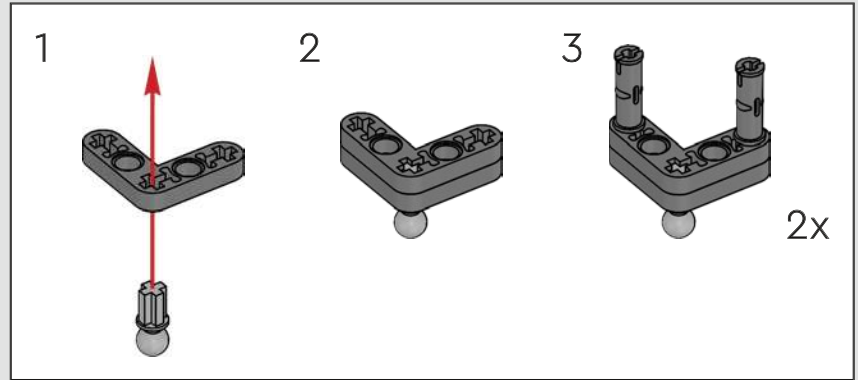



2x

143

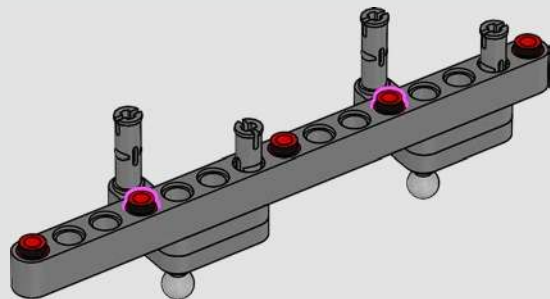

1x

9

144

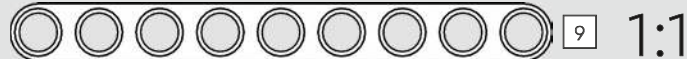
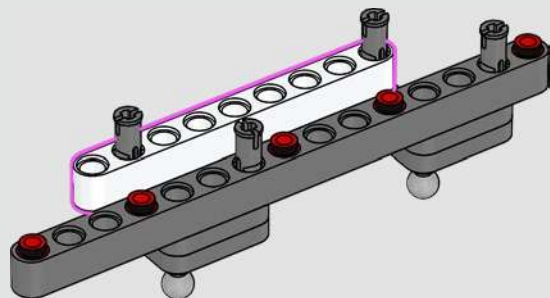

9

1:1



2x



4x



2x

145

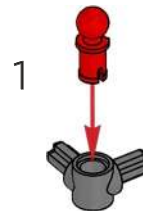

1

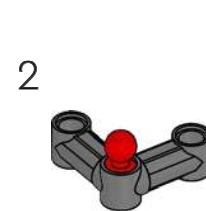

2

2x

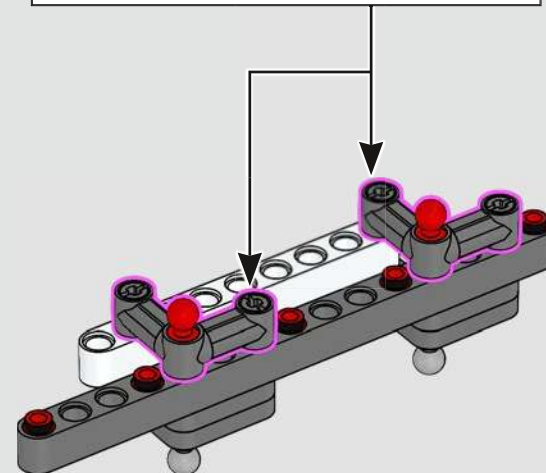

146

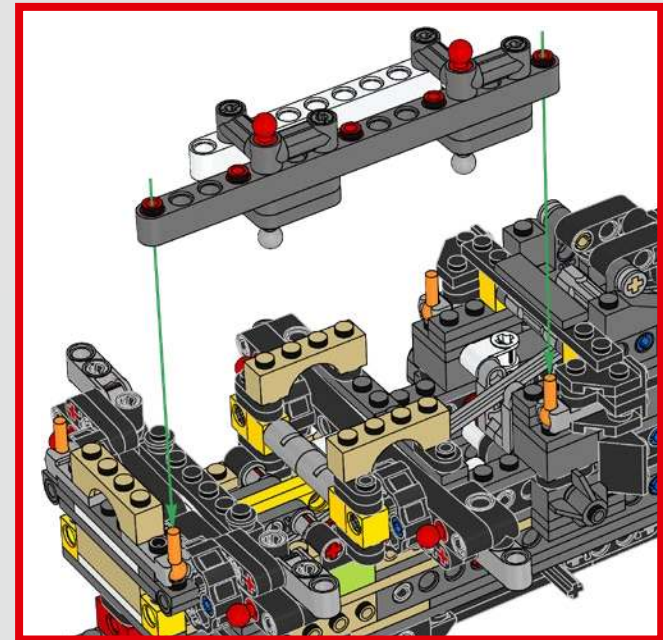
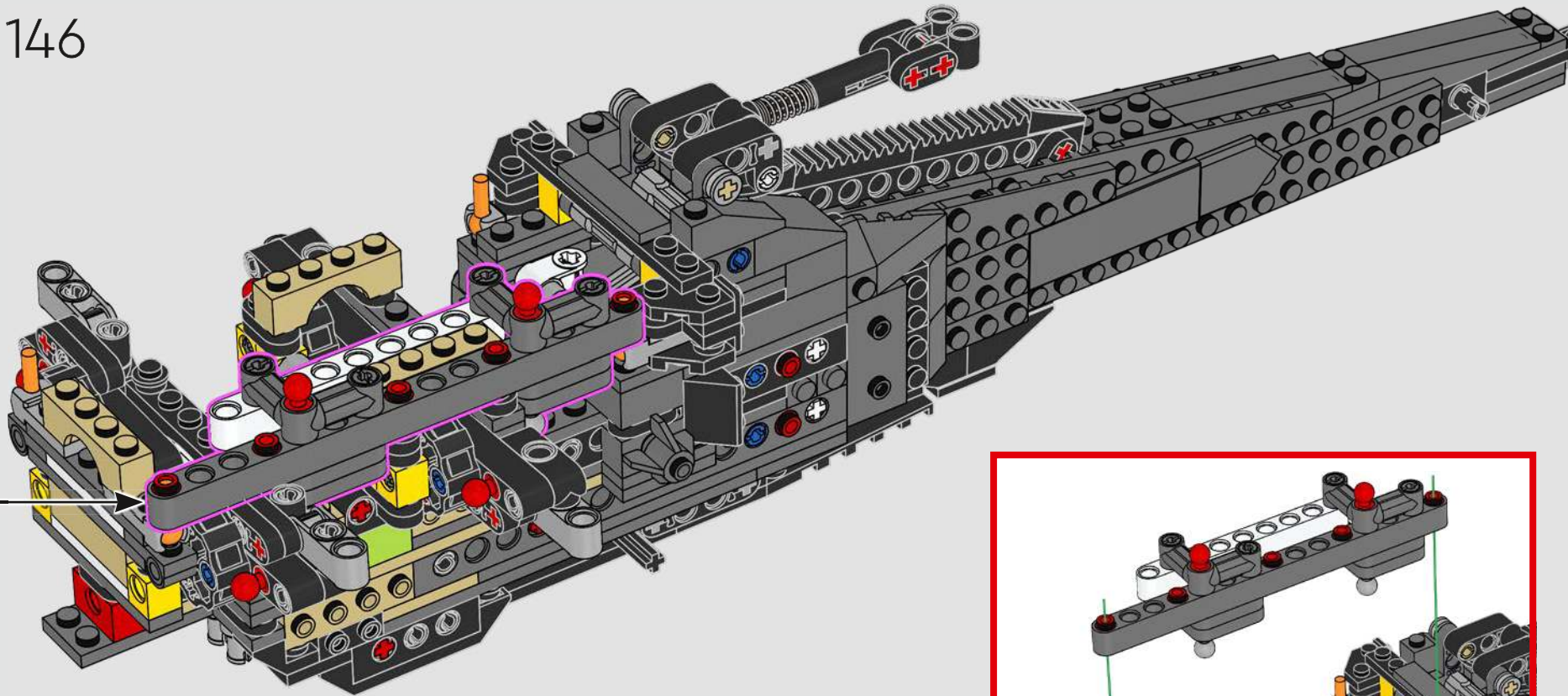

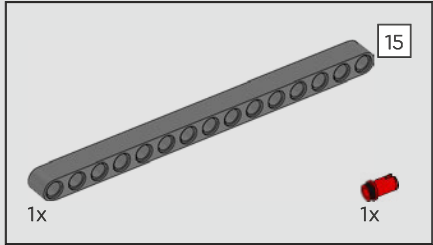
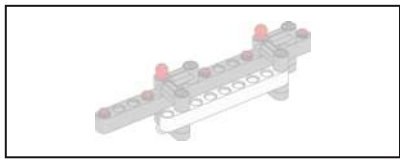

147

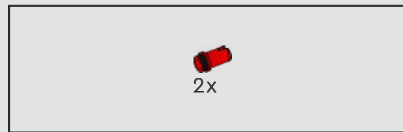
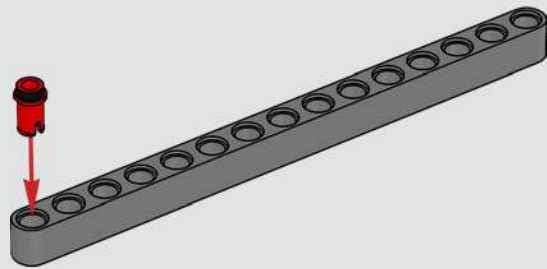

148

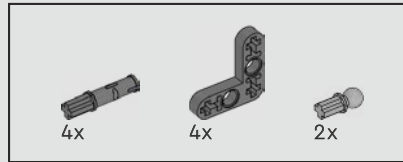
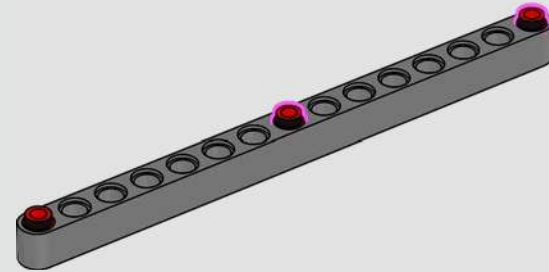

149

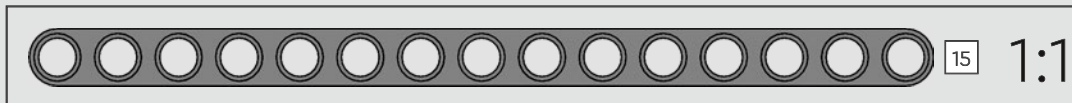
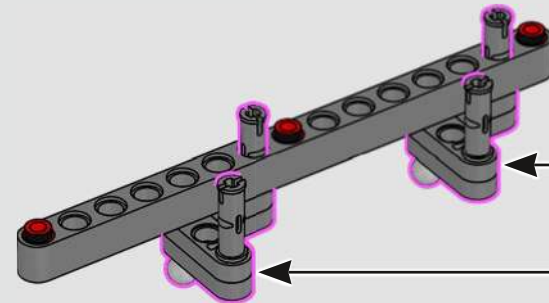
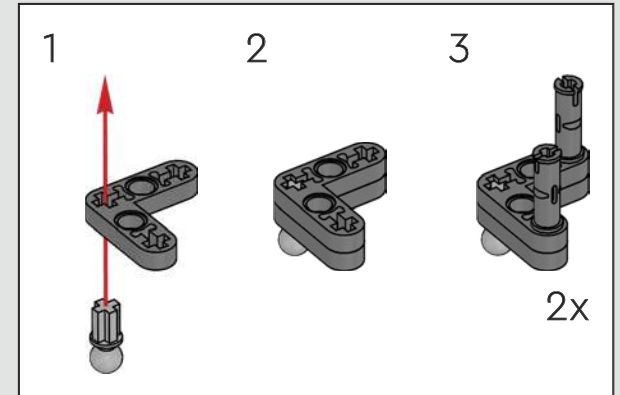



150

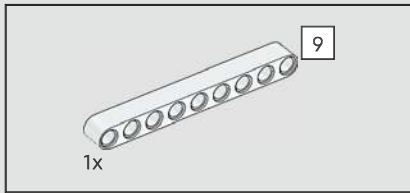
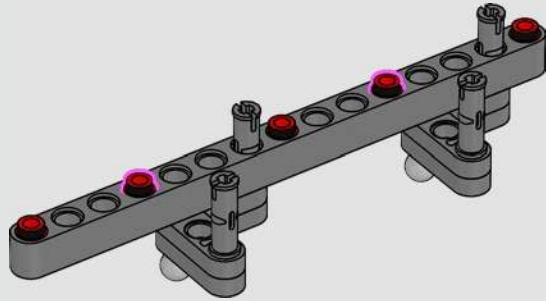

151

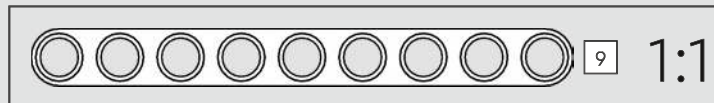
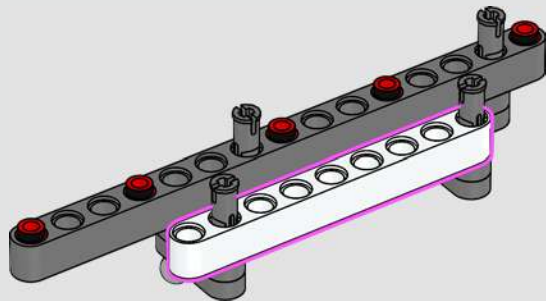

152

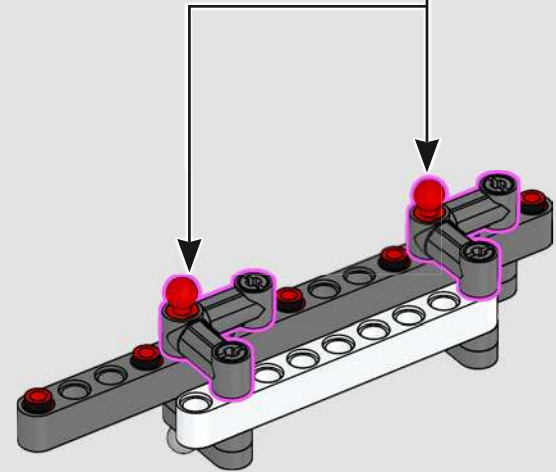
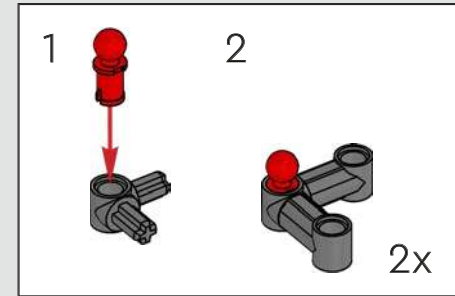

153

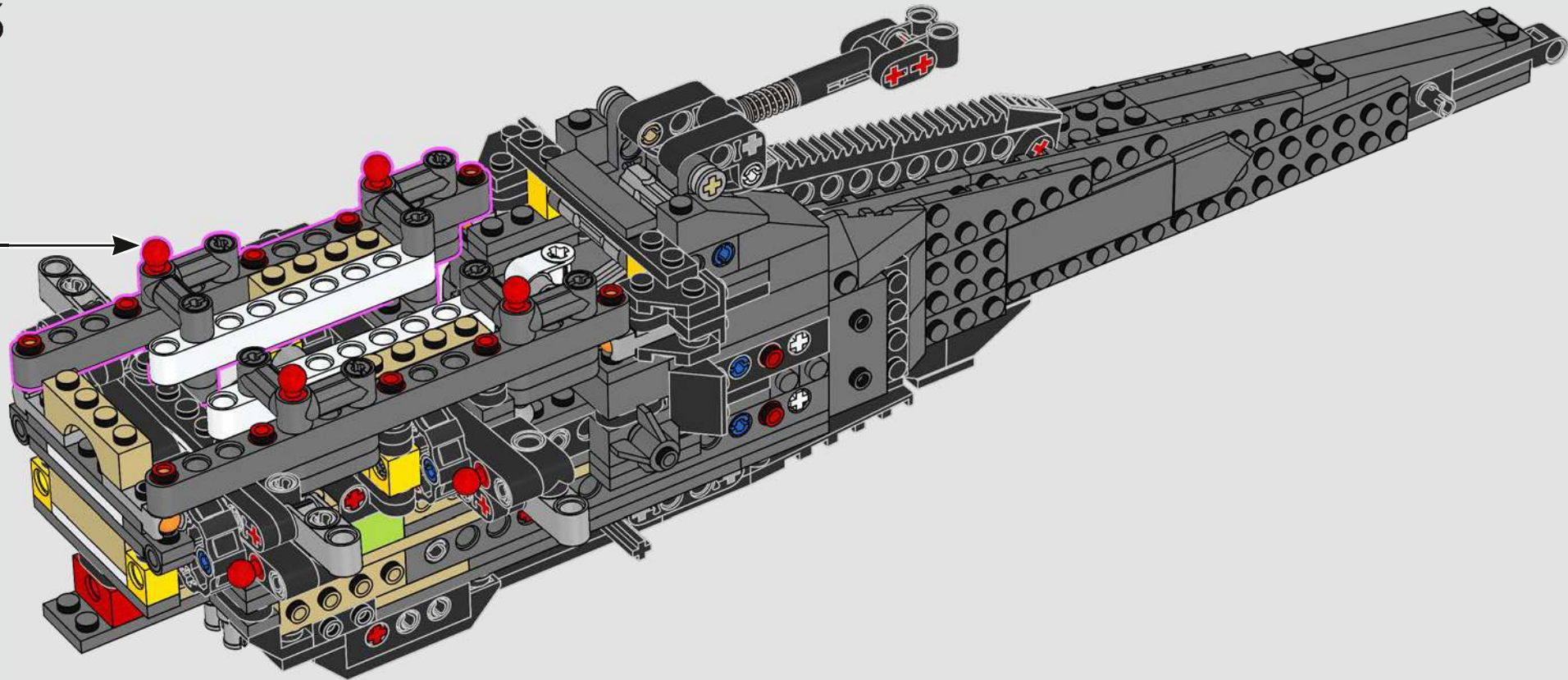

154

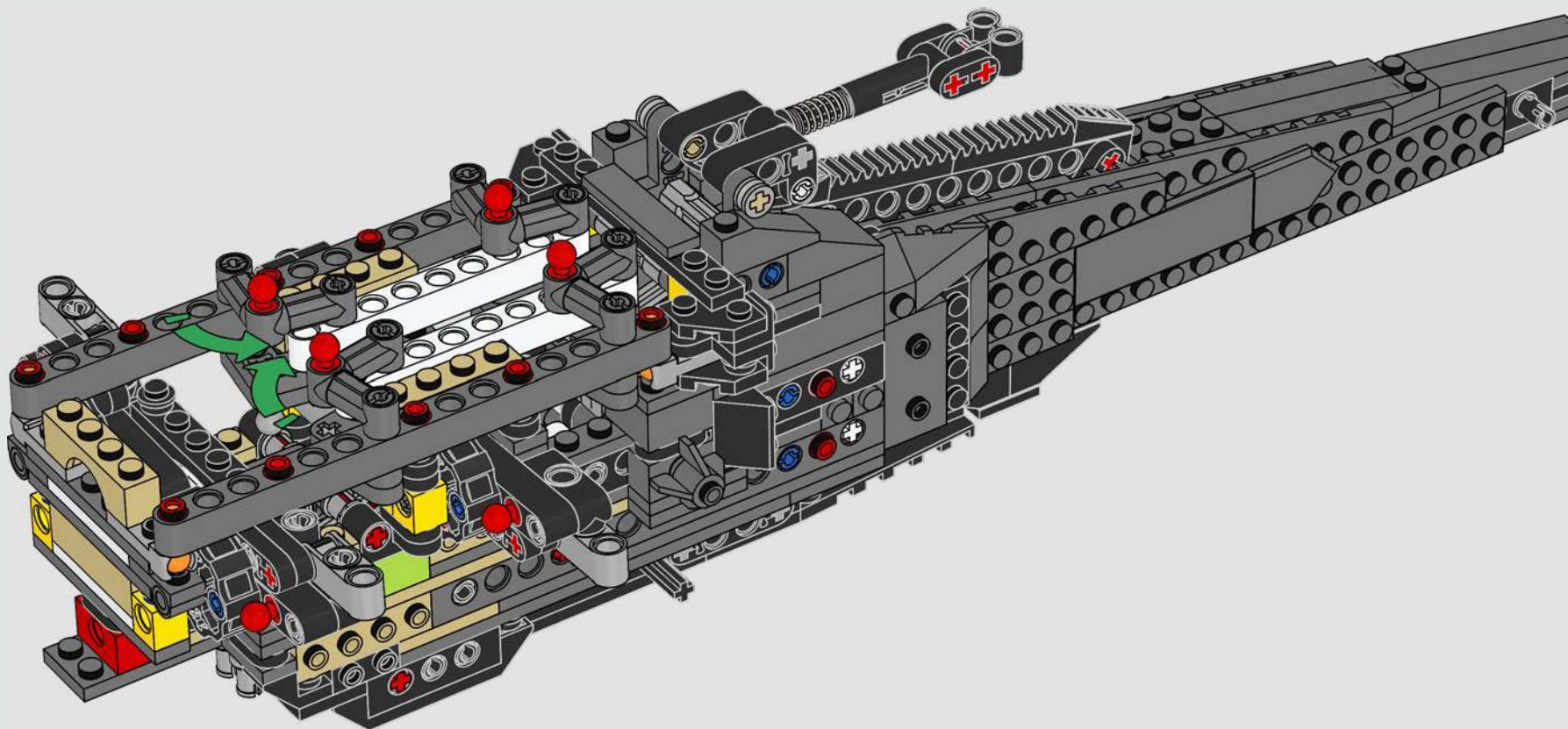

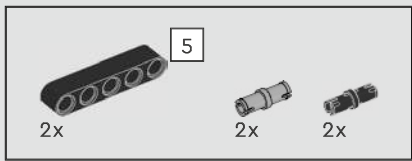

155

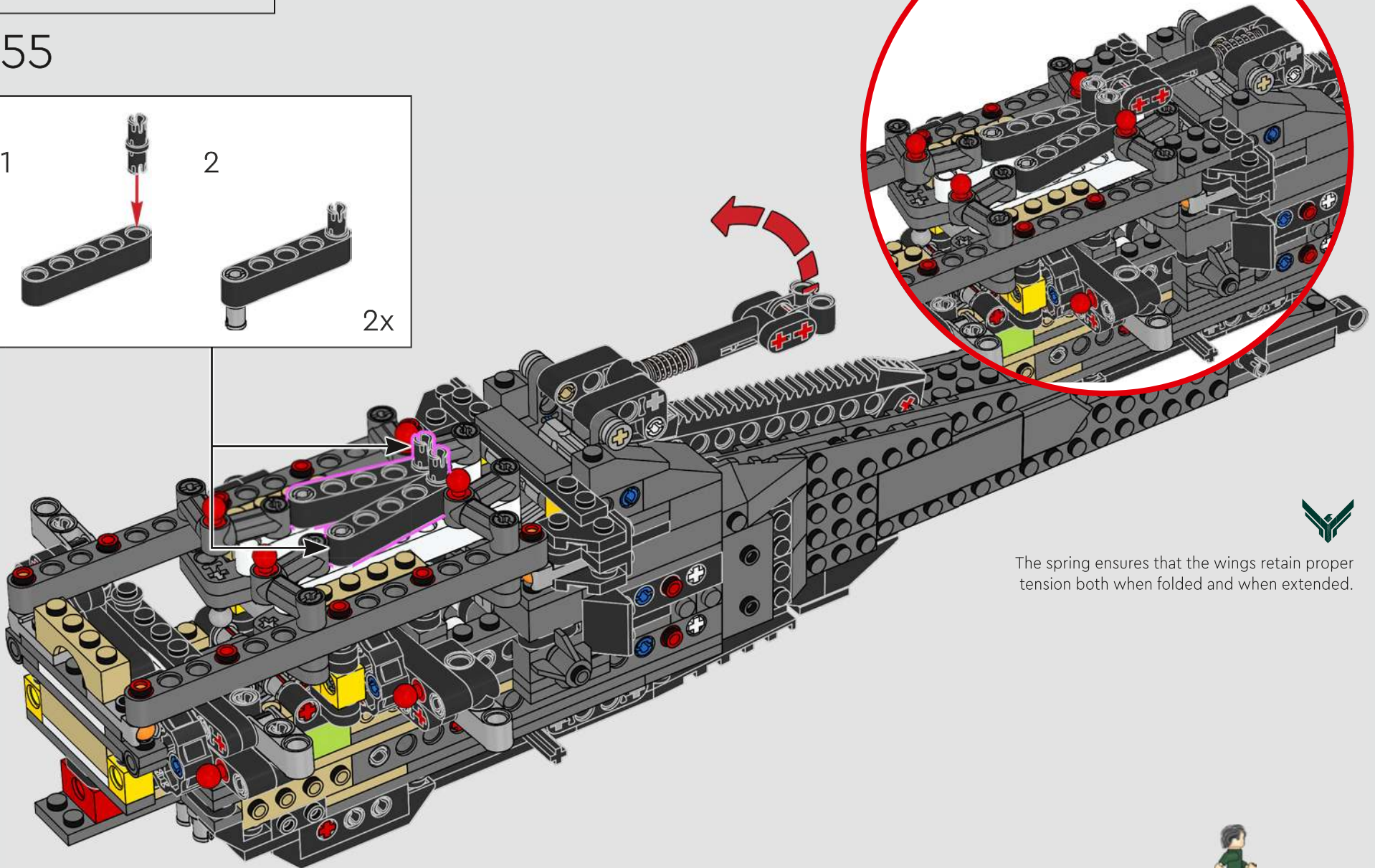
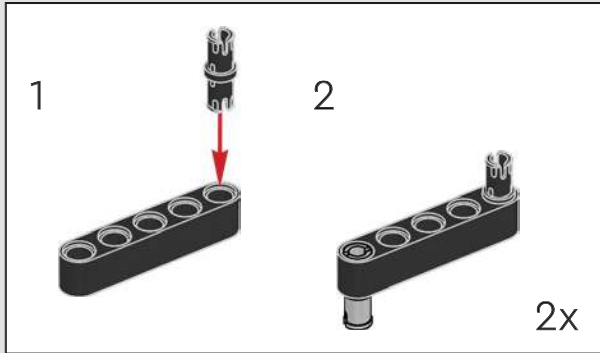

The spring ensures that the wings retain proper tension both when folded and when extended.





156

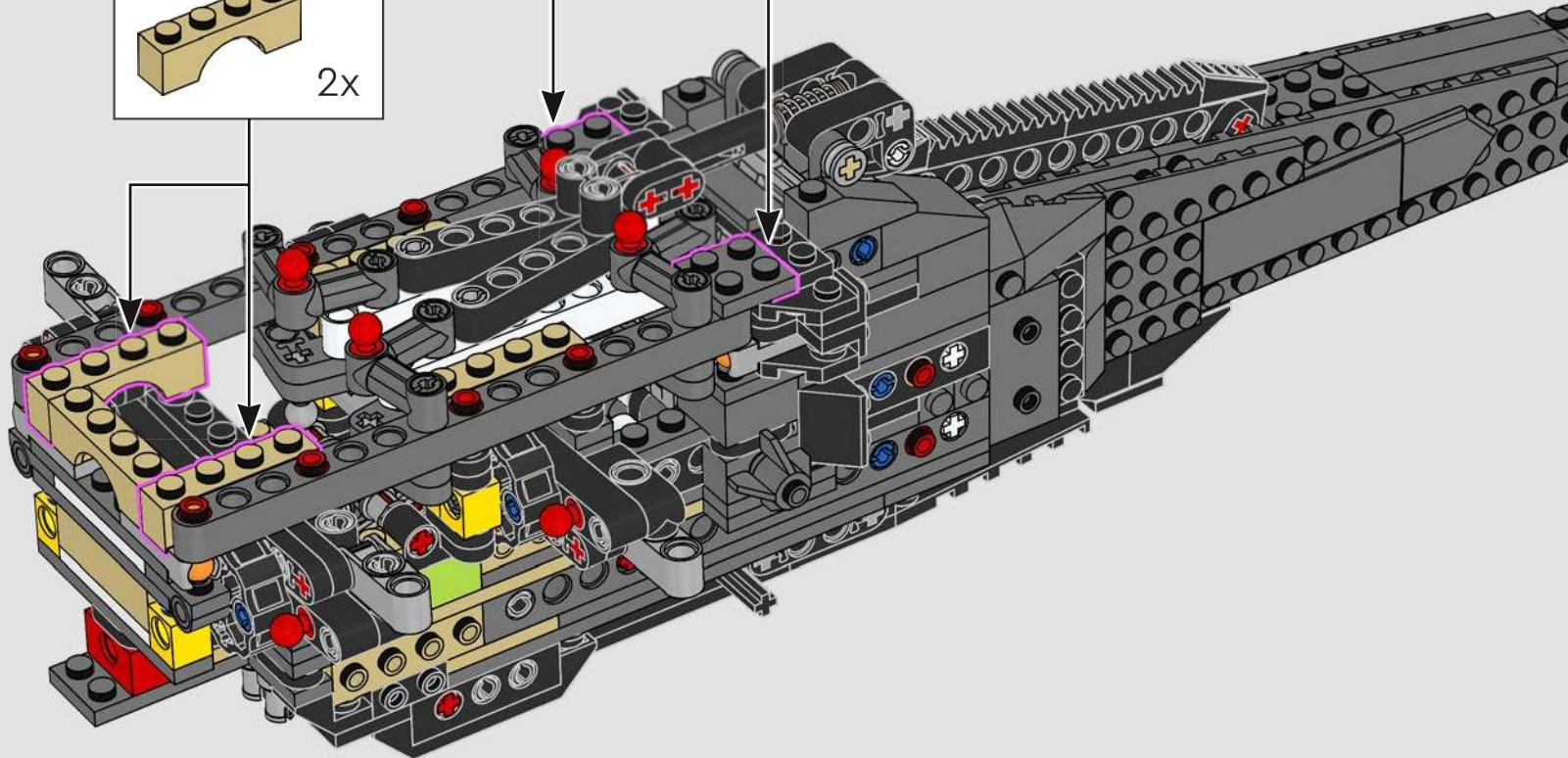
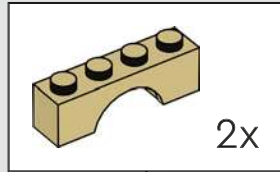
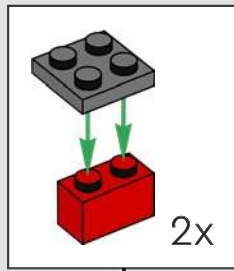

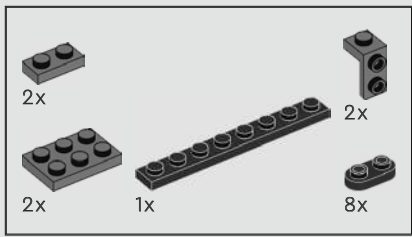

157

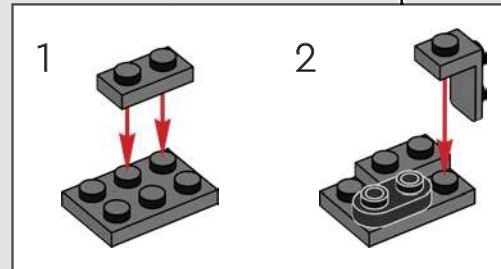
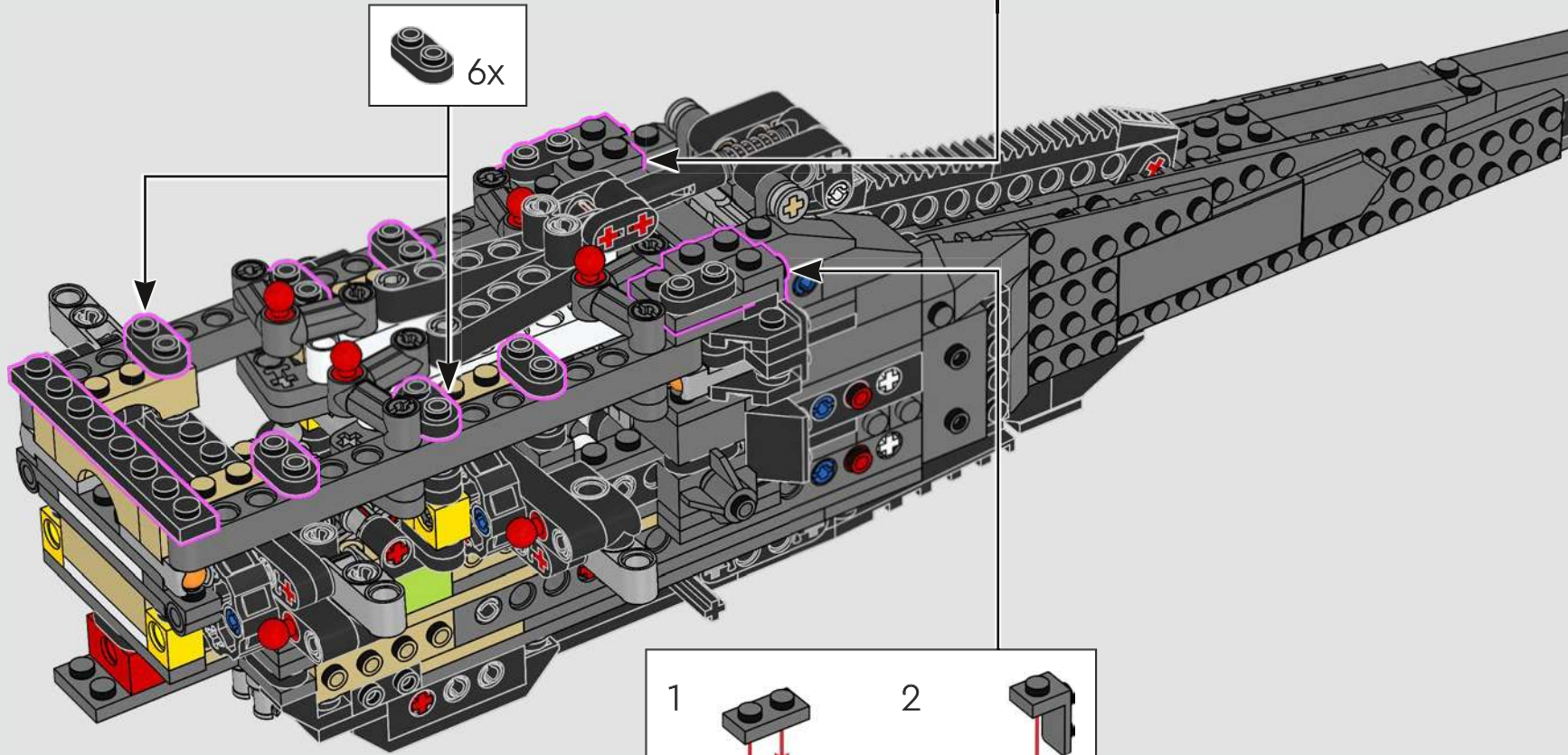
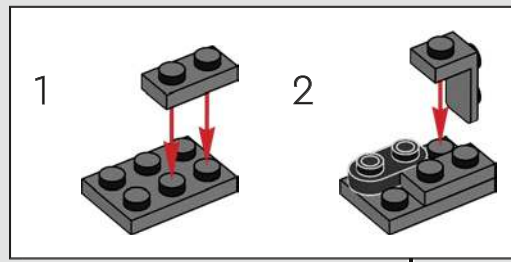



1

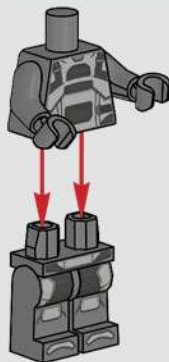

2

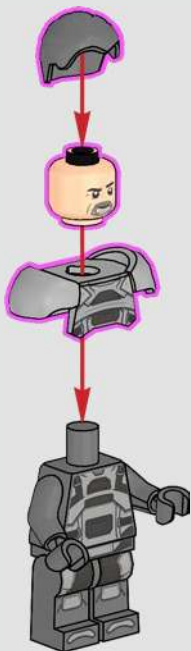

3



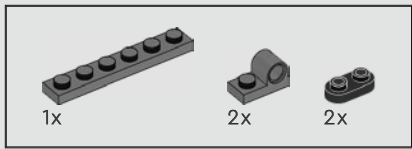

158

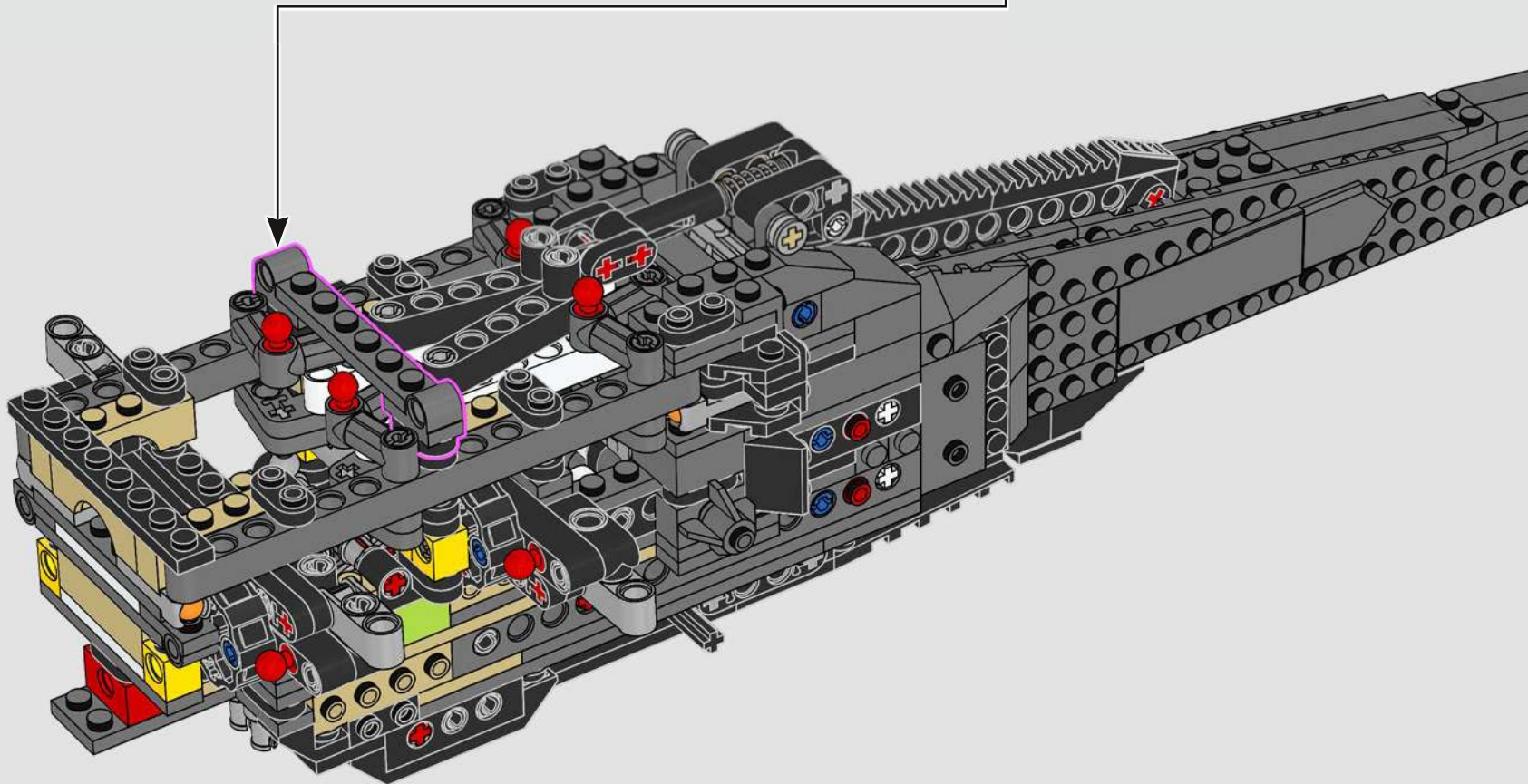
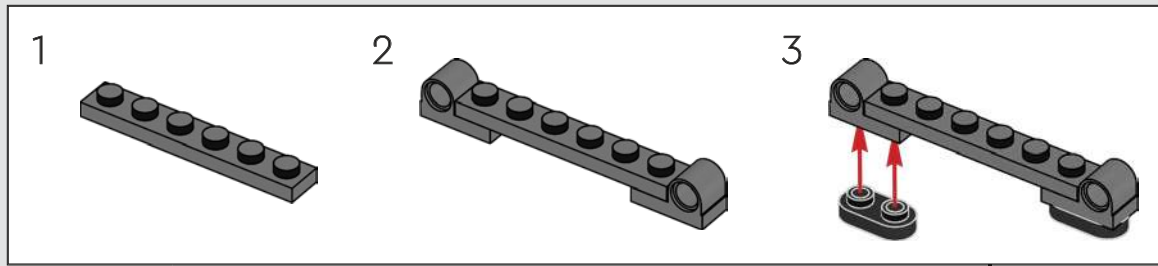

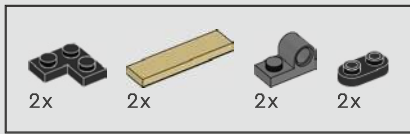

159

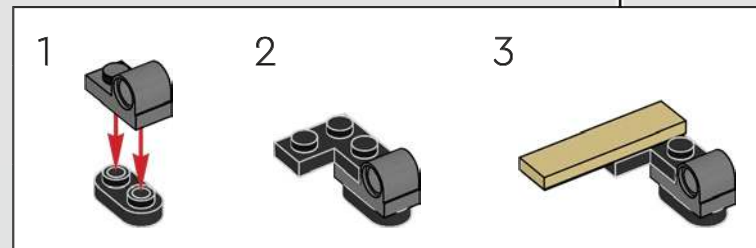
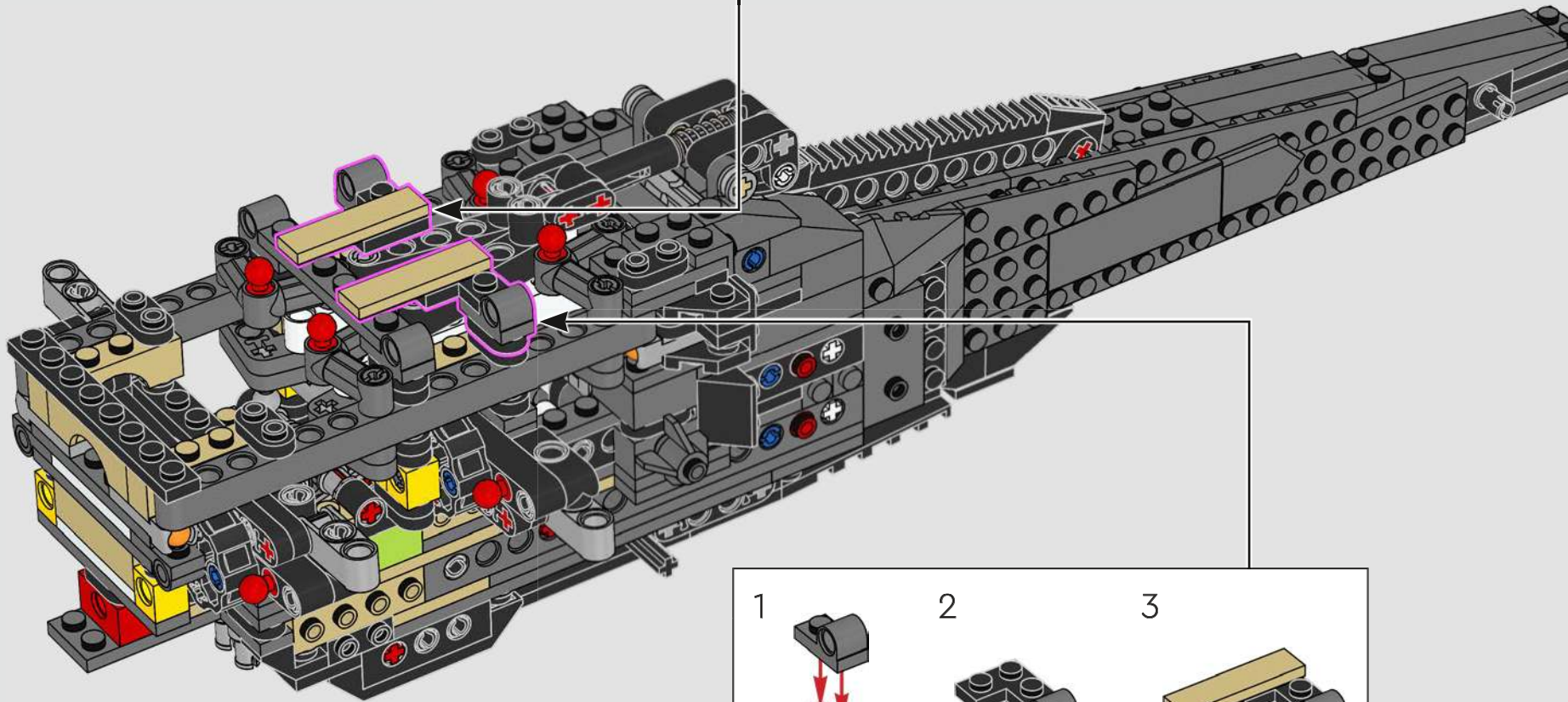
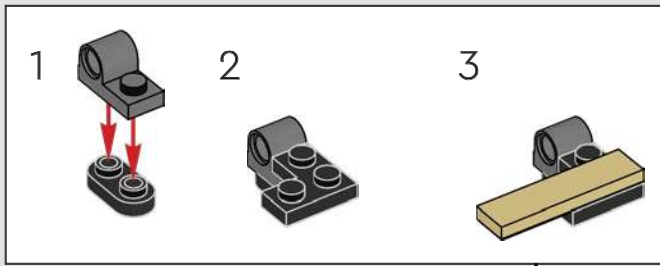

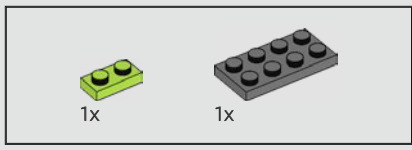

160

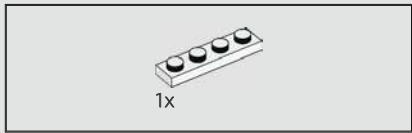
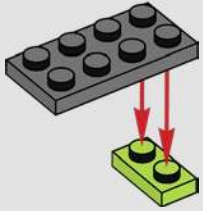

161

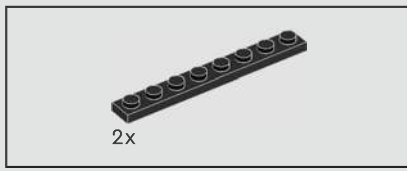
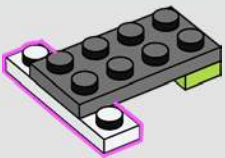

162

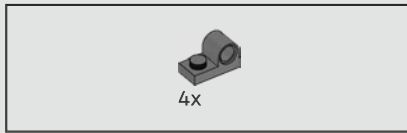
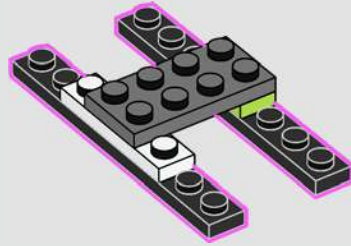

163

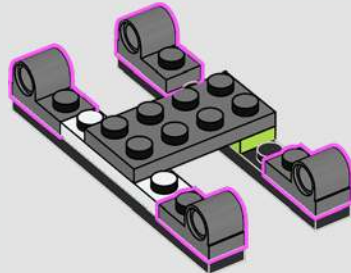

164

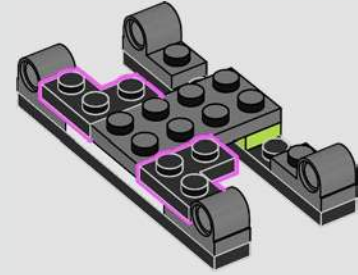

165

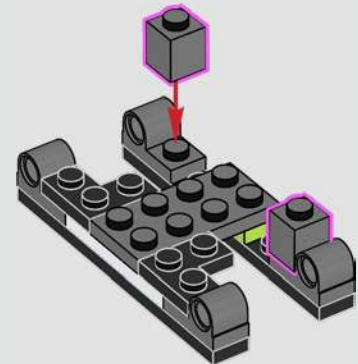

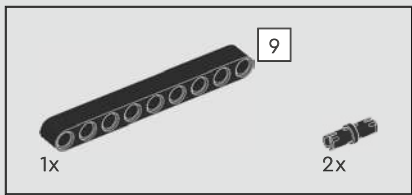

169

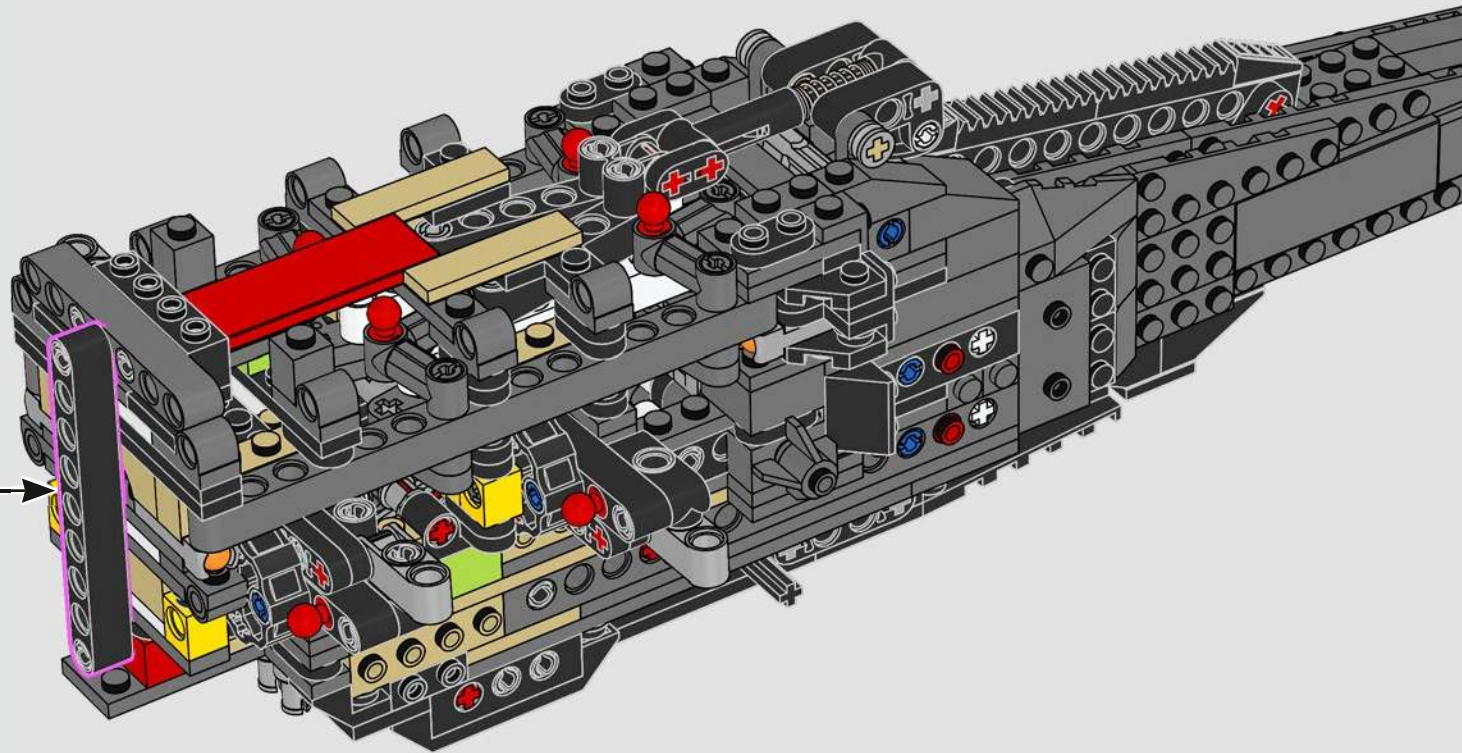
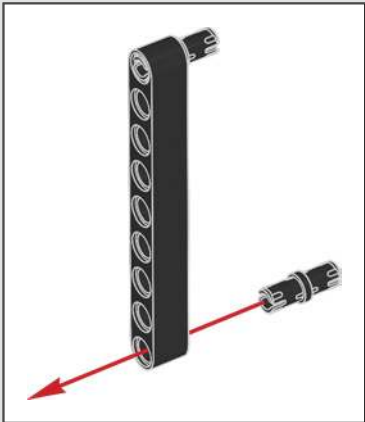

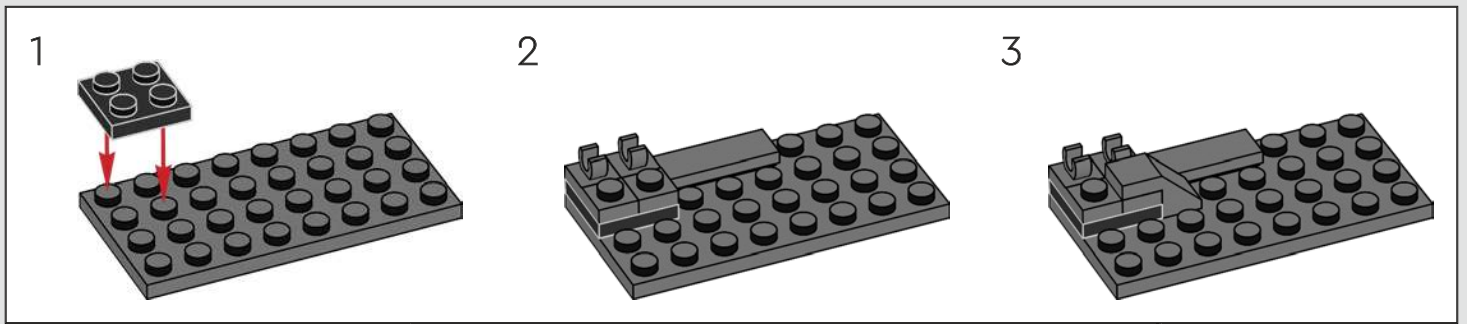
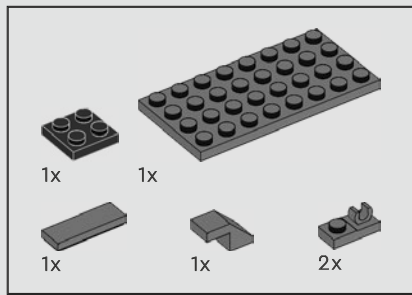

170

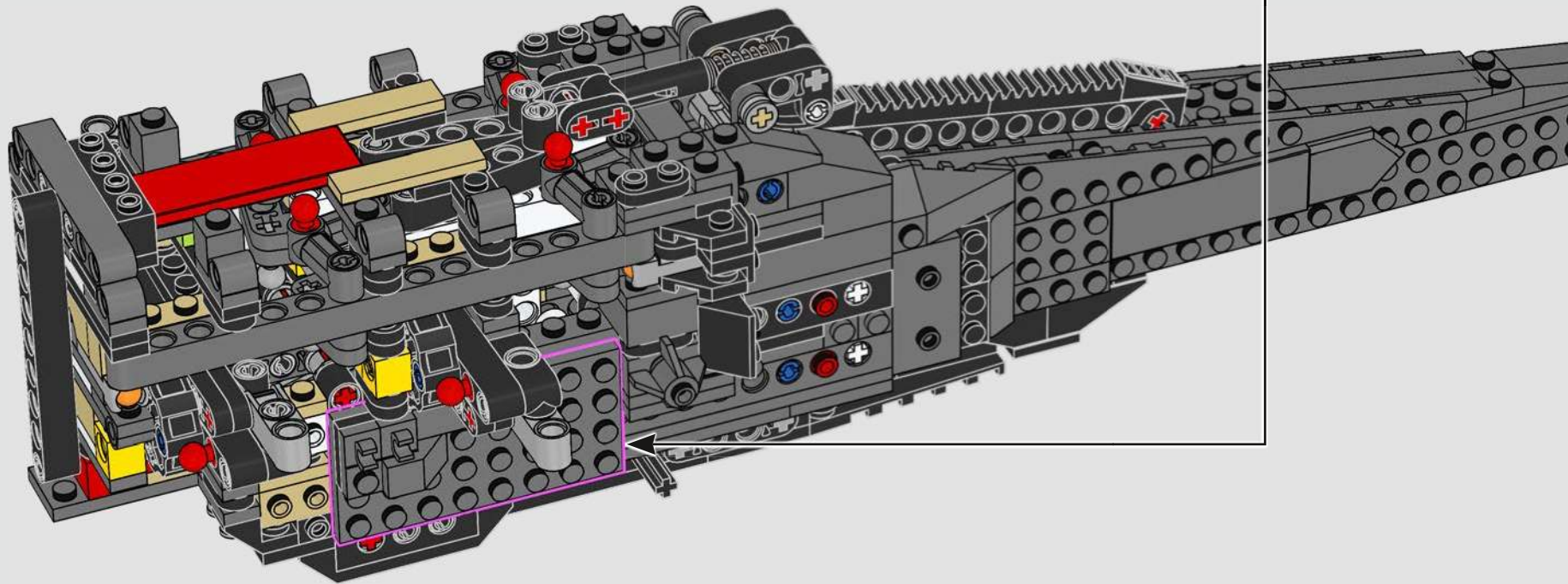

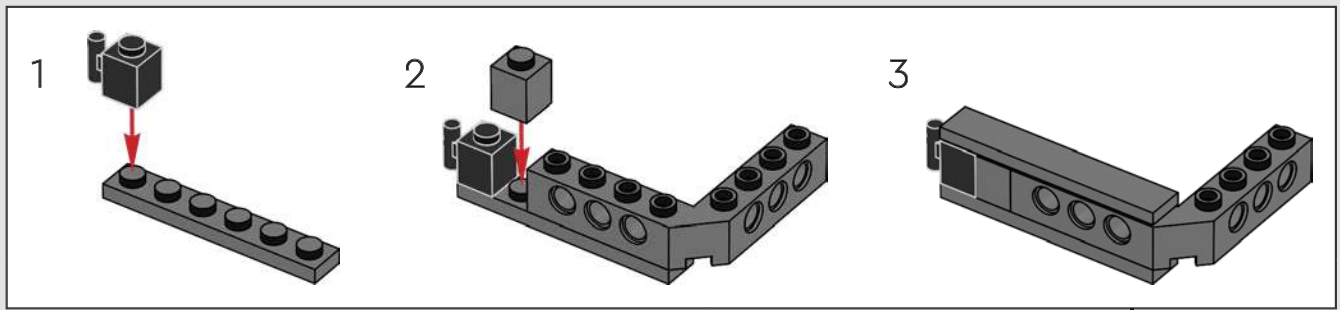
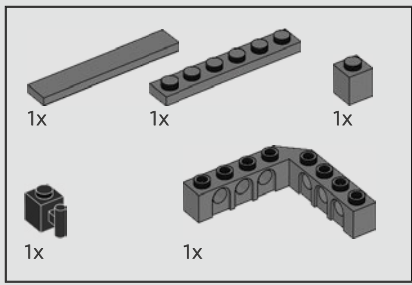

171

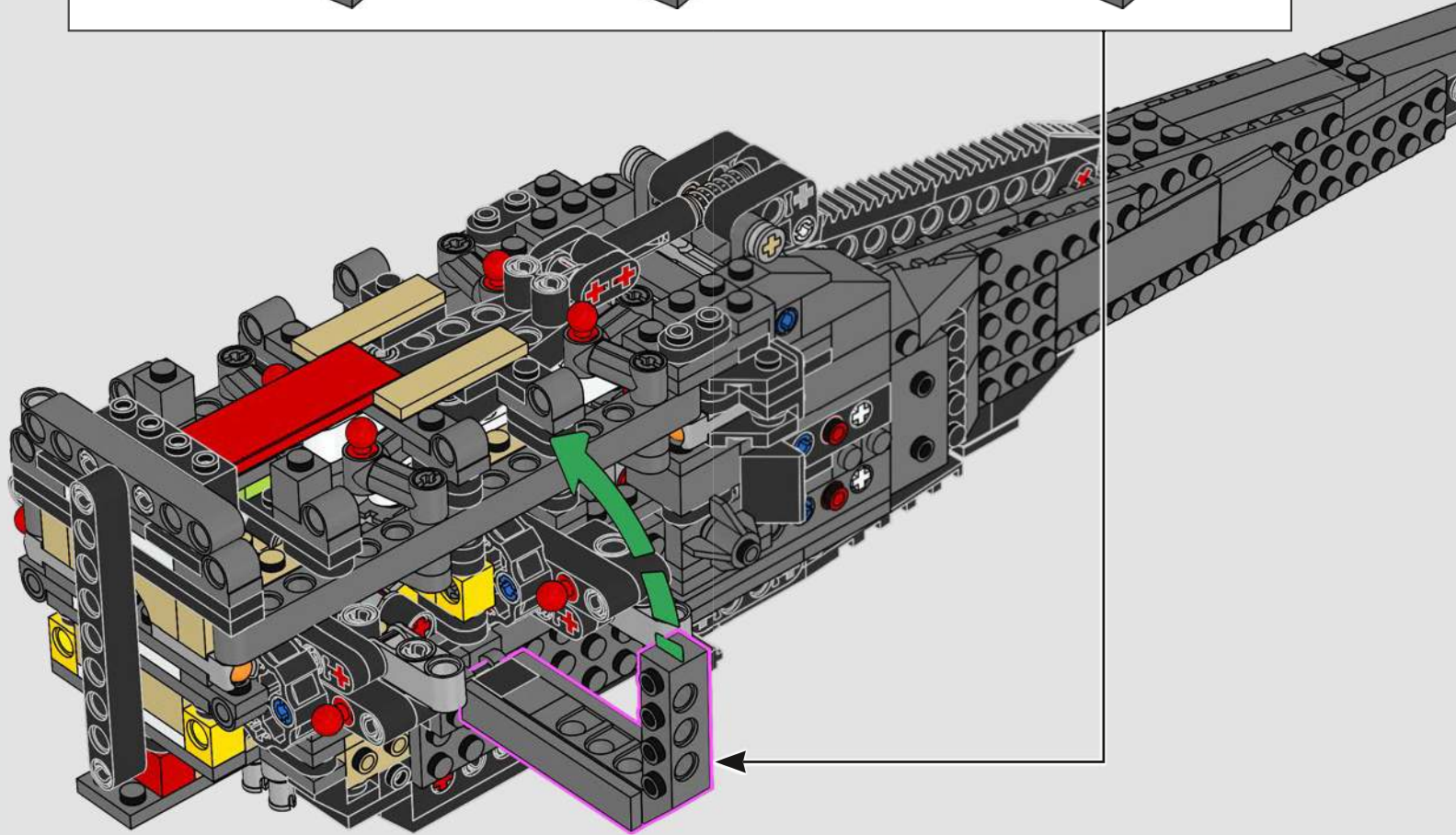

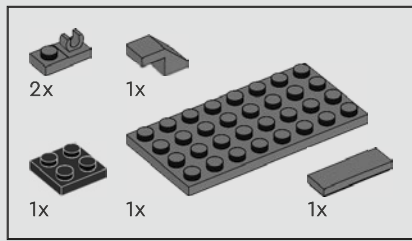

172

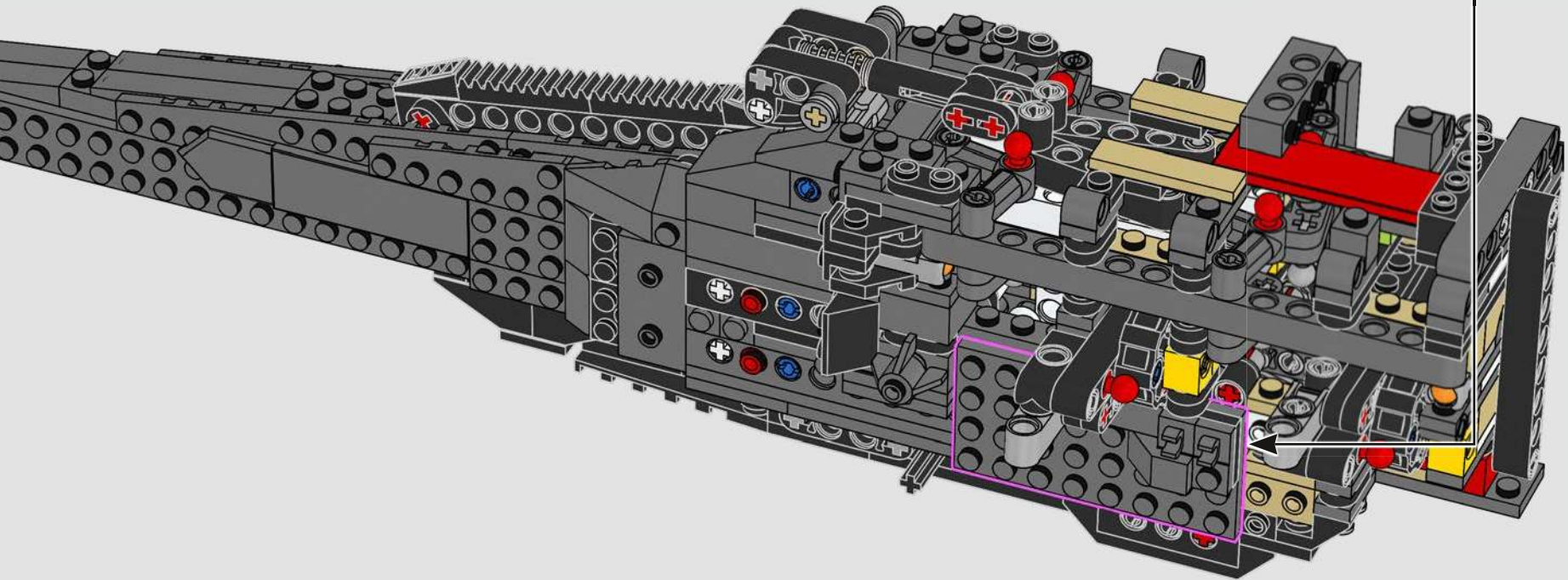
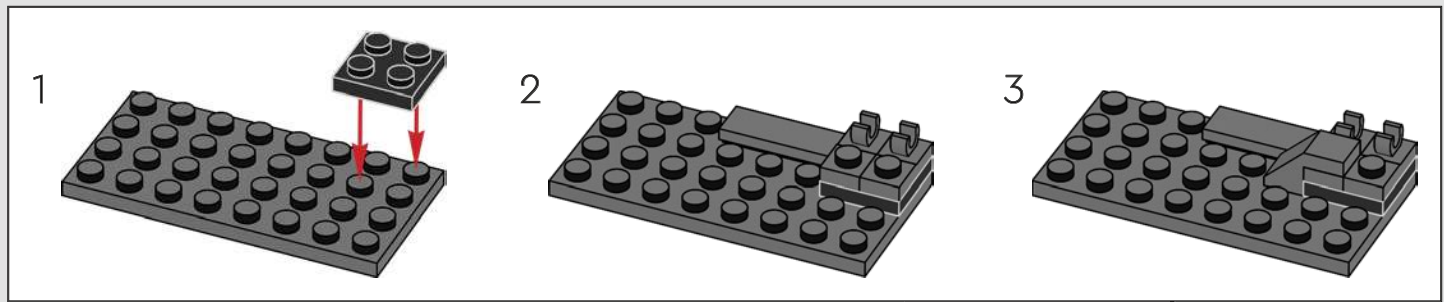

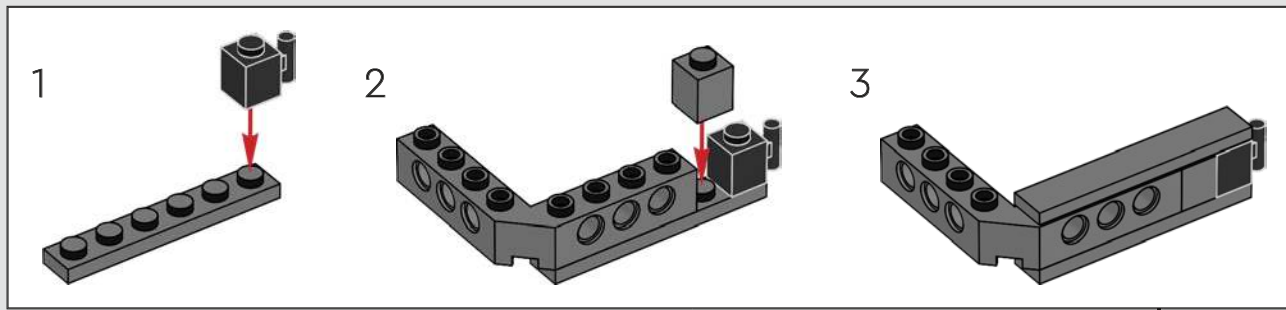
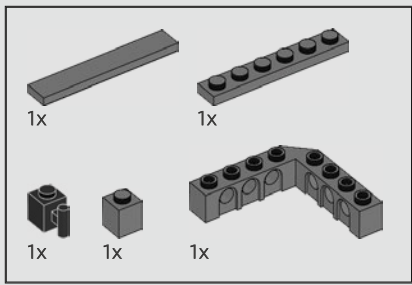

173

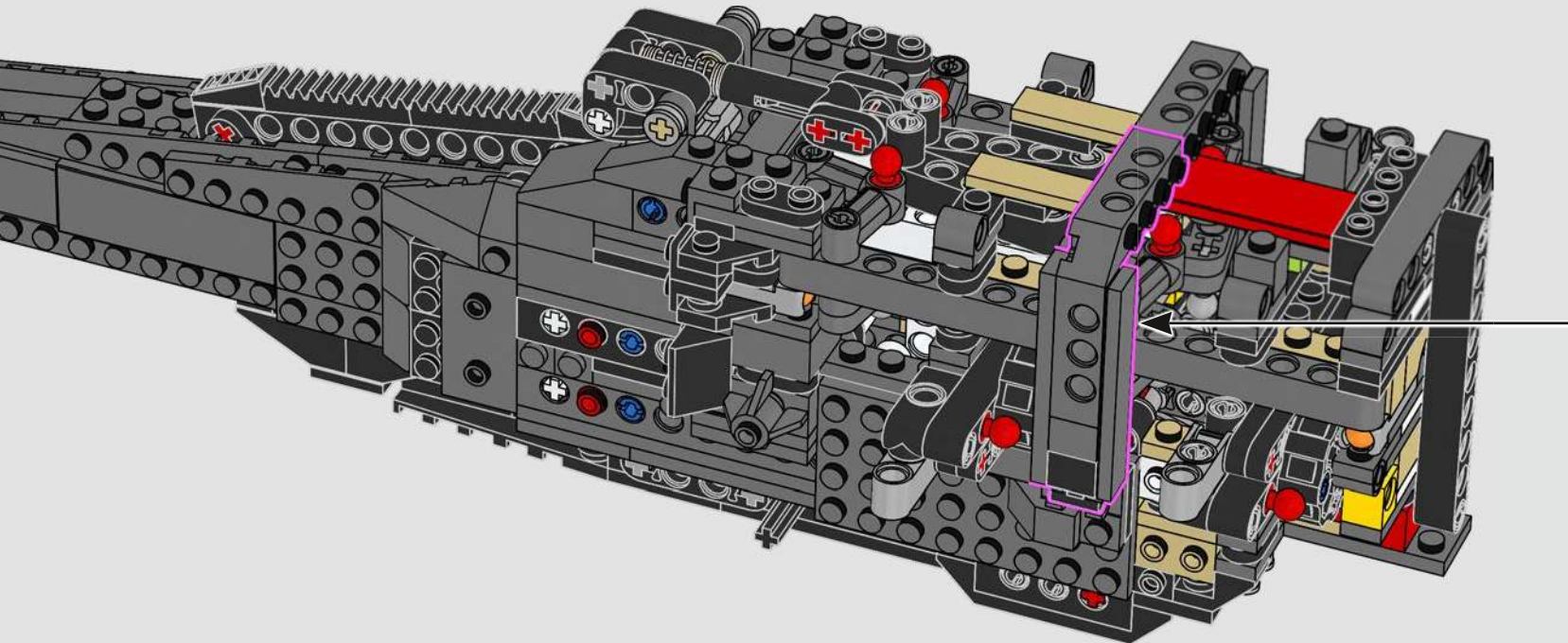

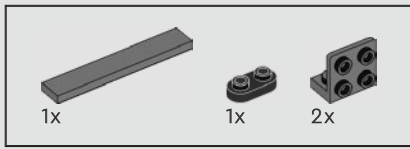

174

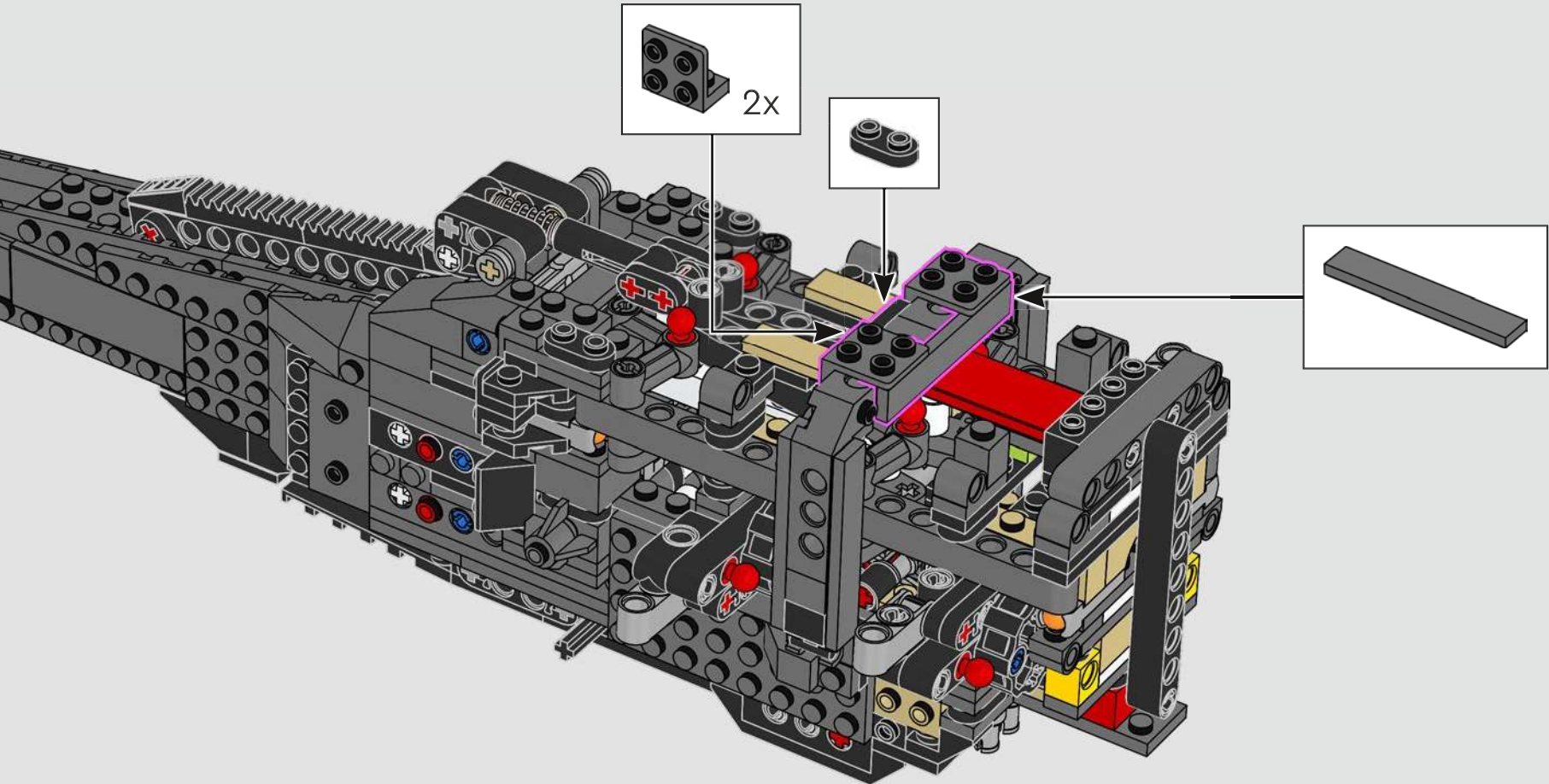

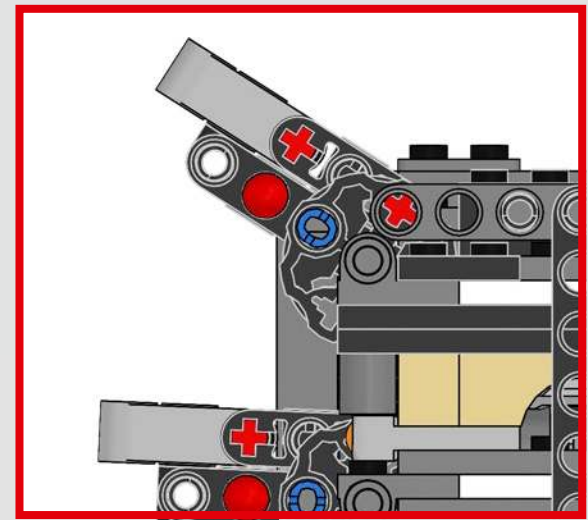
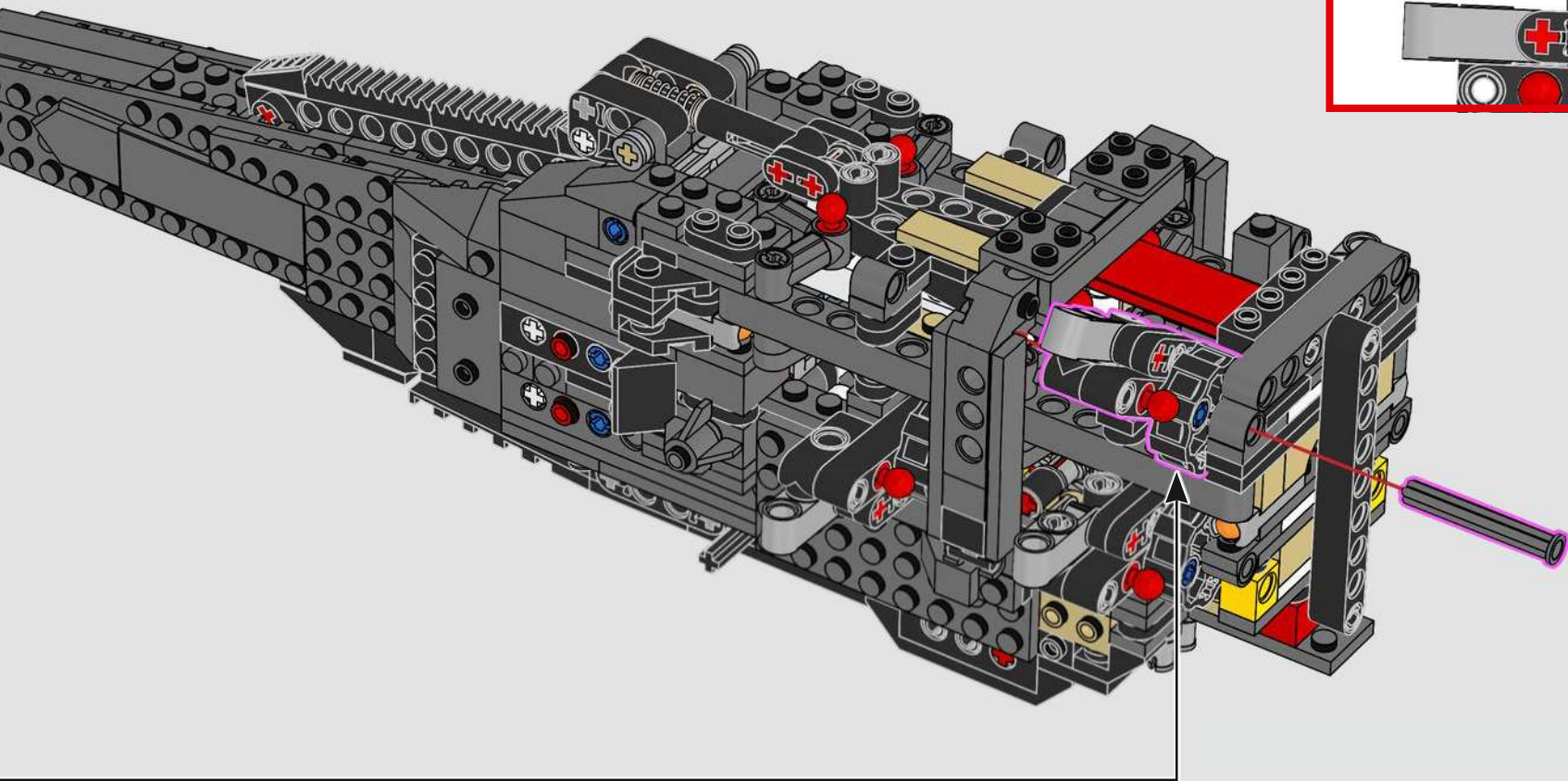

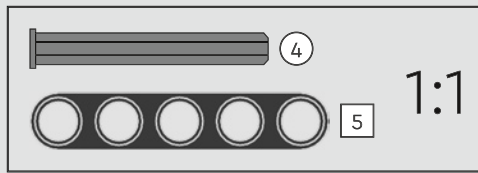
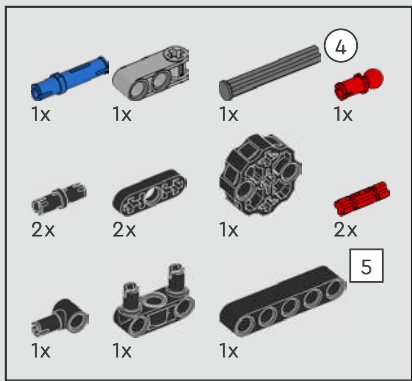

176

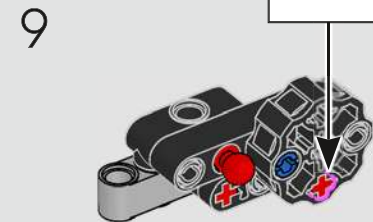
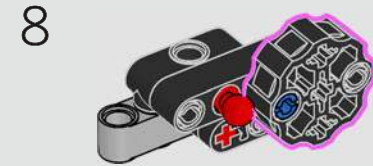
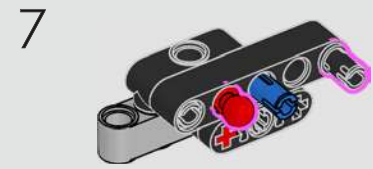
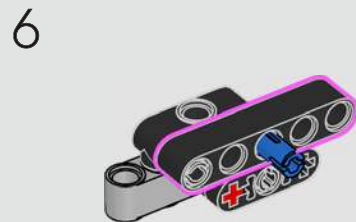
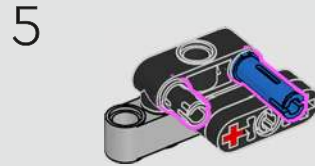
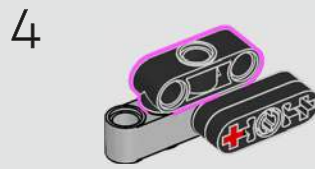
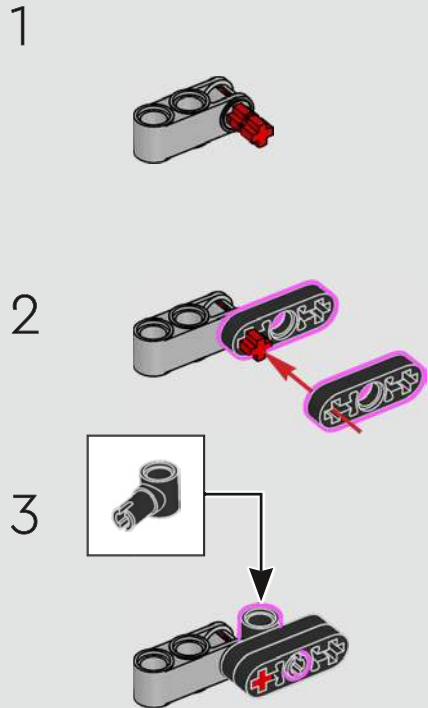

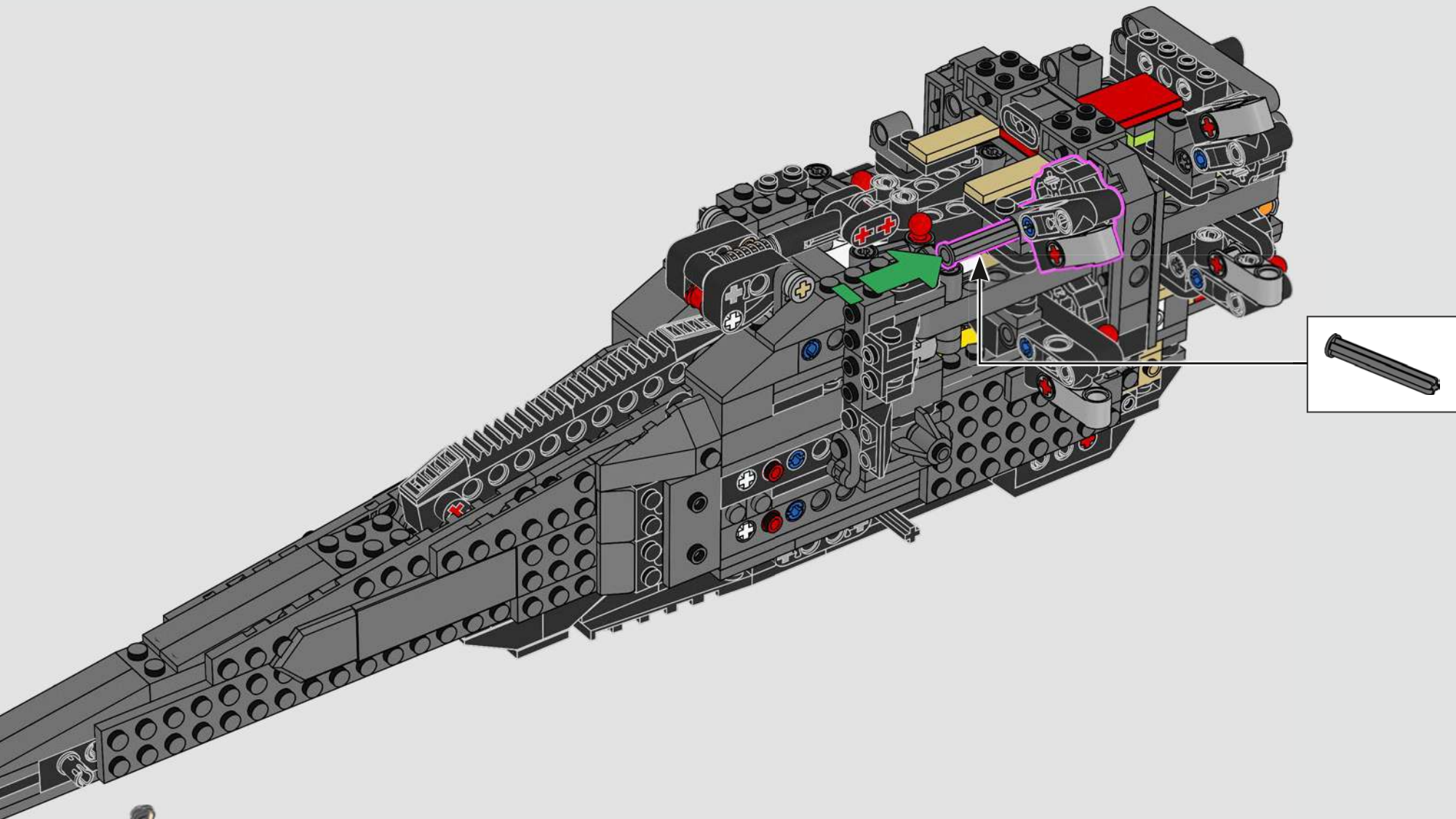

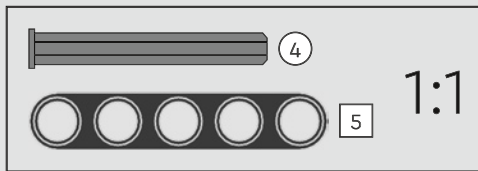
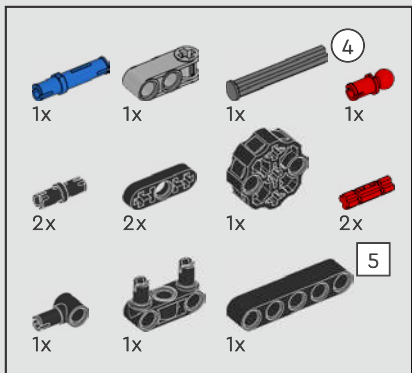

177

1



2

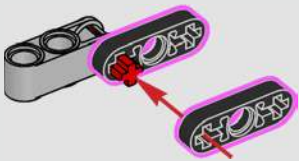

3

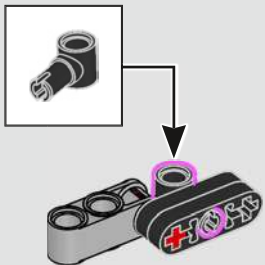

4



5



6

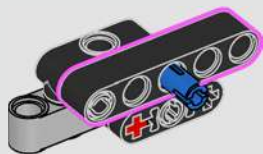

7

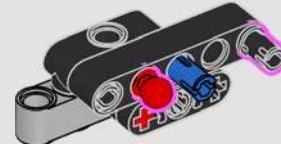

8

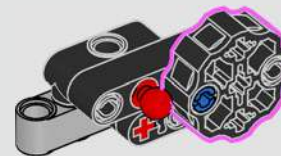

9

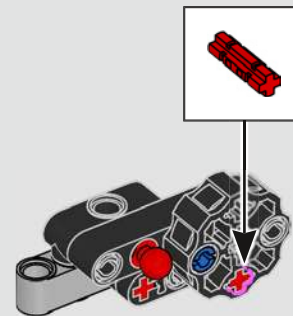

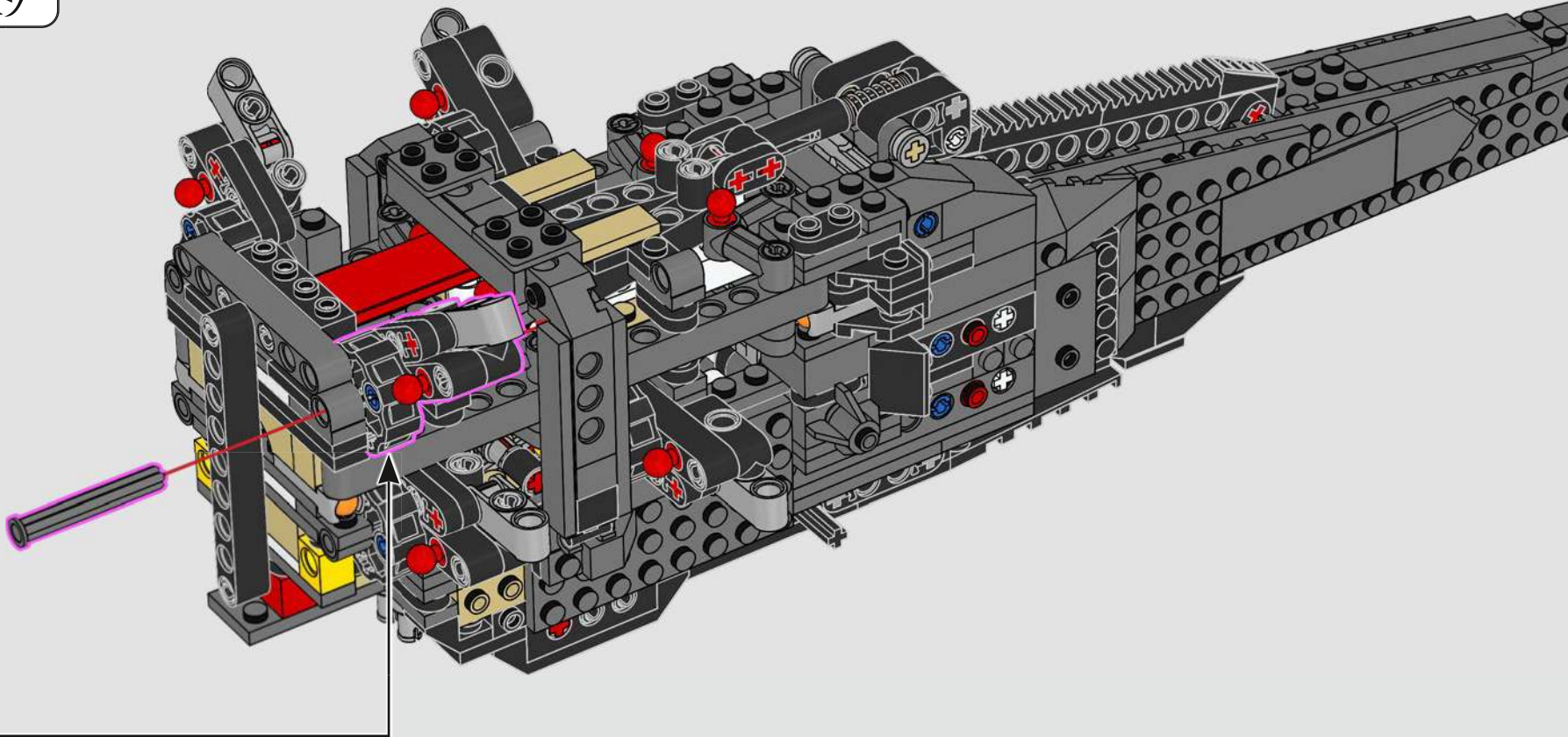

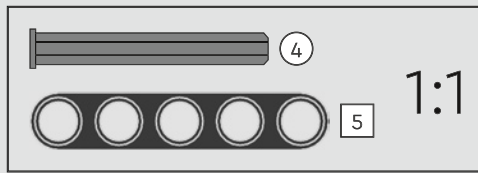
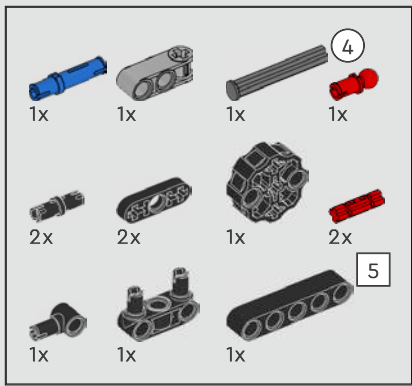

178

1



2

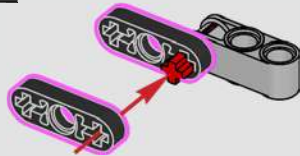

3

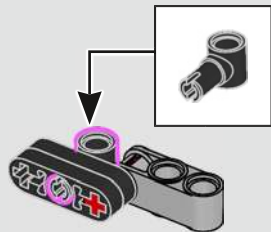

4



5



6

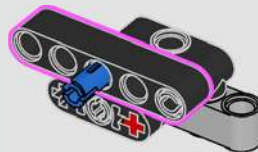

7

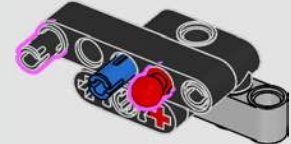

8

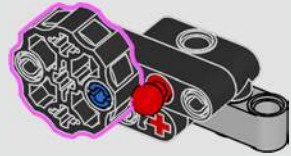

9

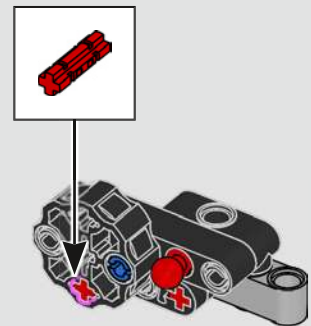

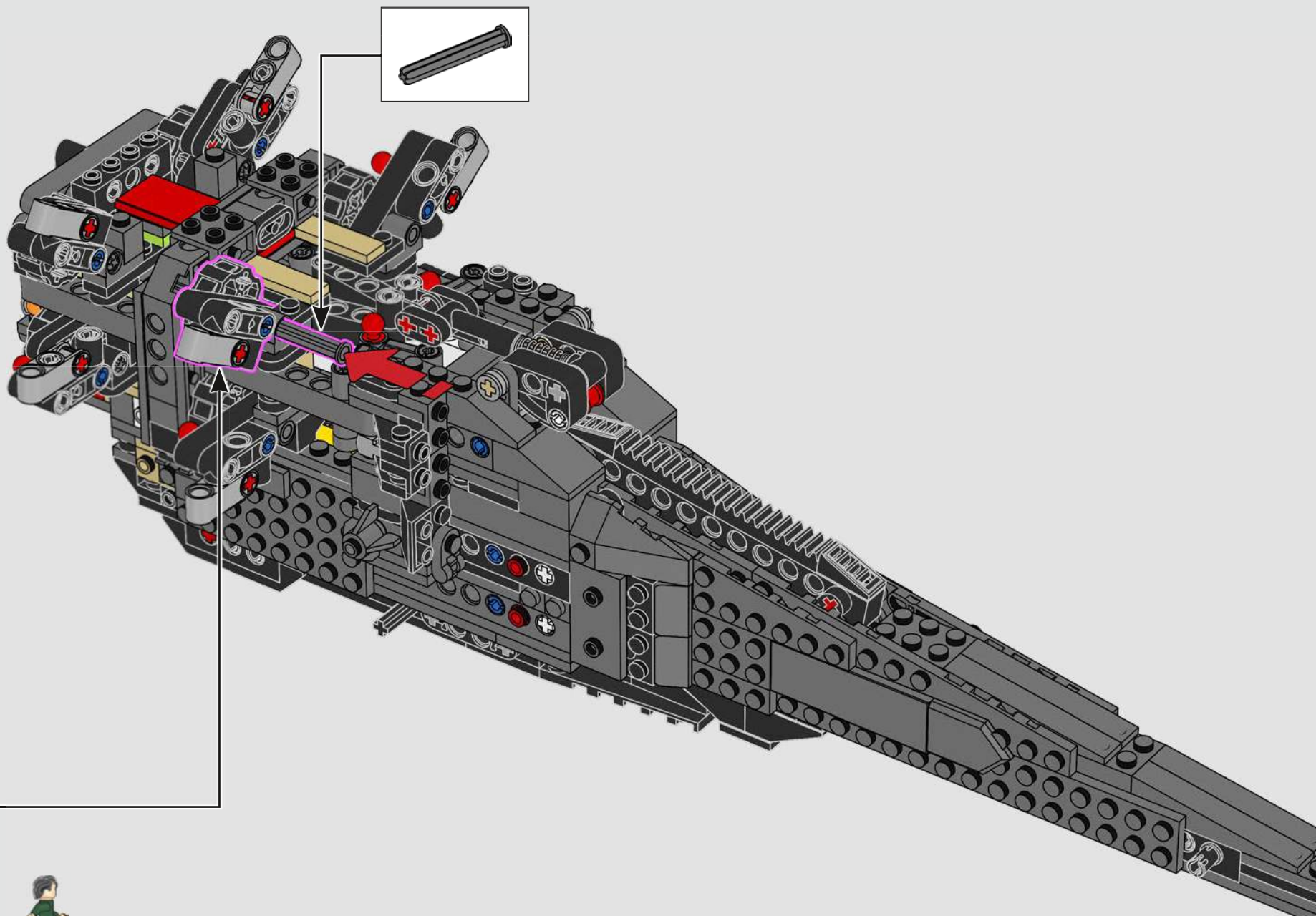

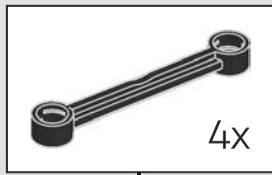
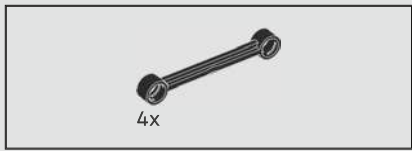

179

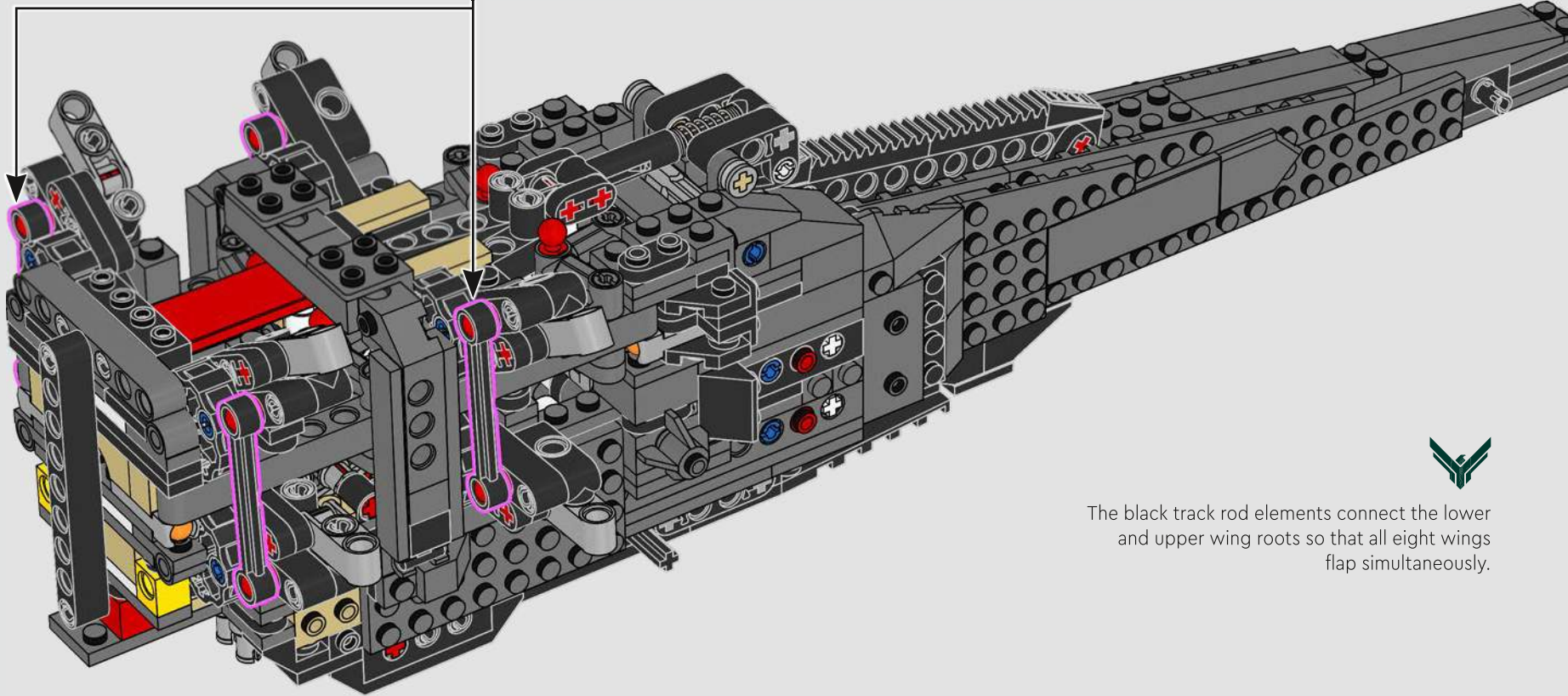

The black track rod elements connect the lower and upper wing roots so that all eight wings flap simultaneously.

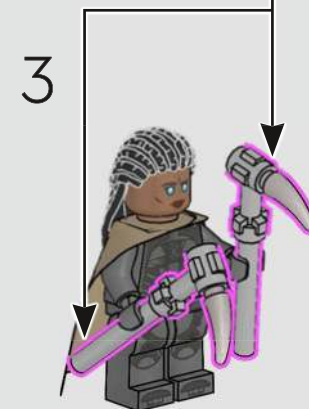
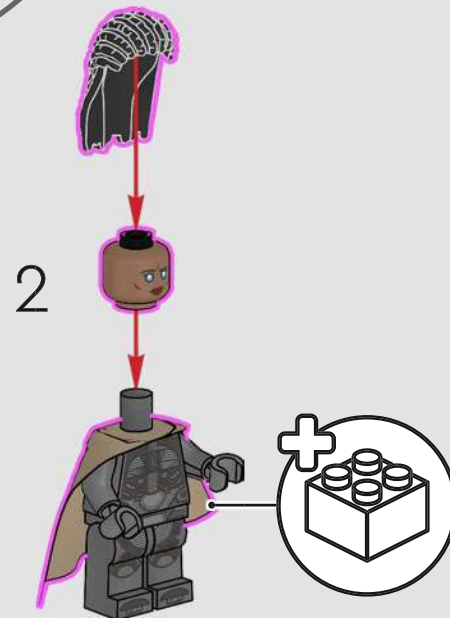
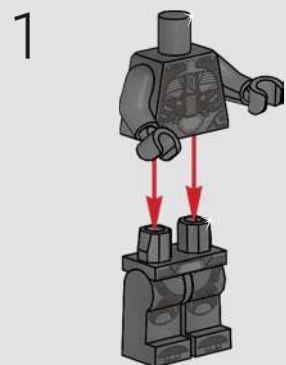
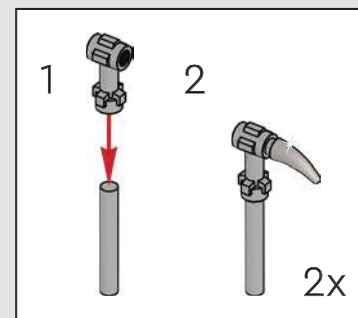
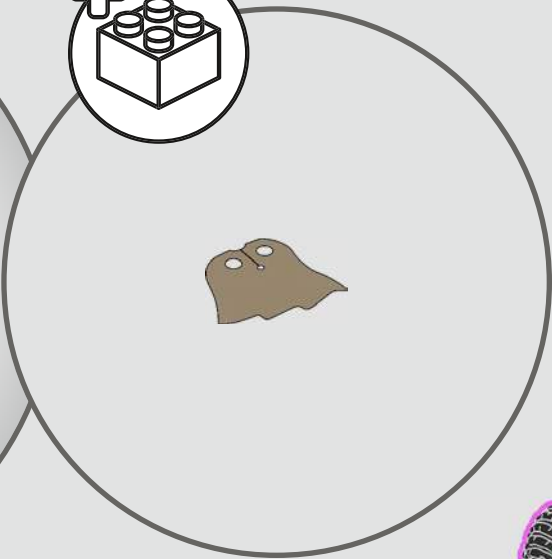
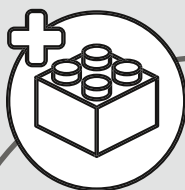



4x

180

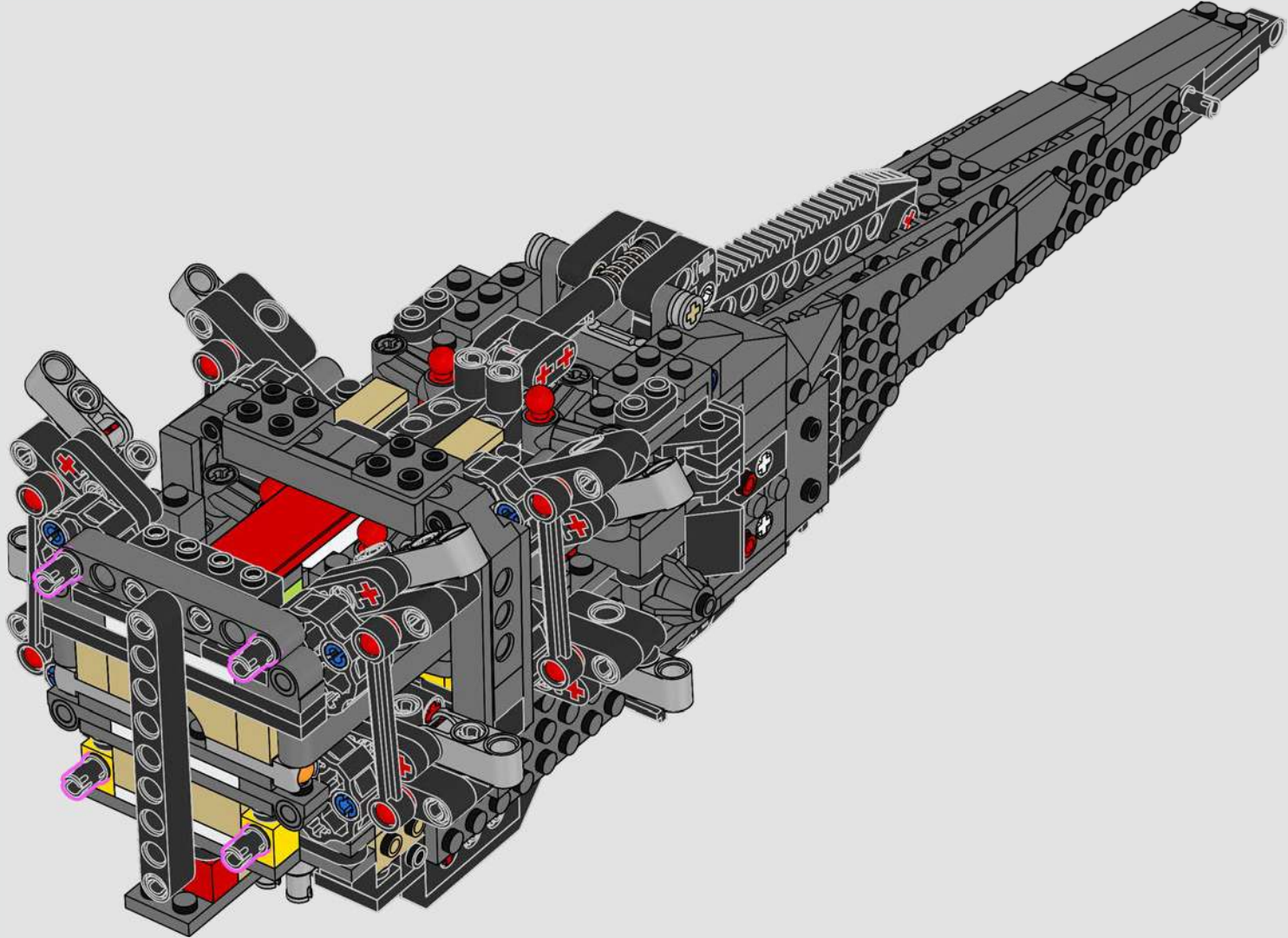

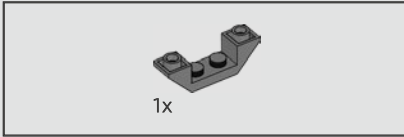
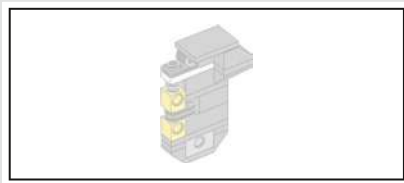

181

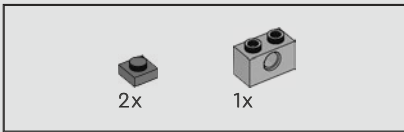
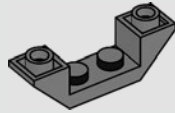

182

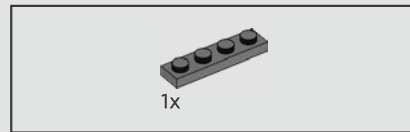
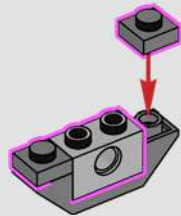

183

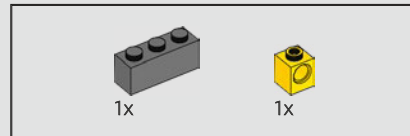
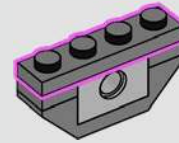

184

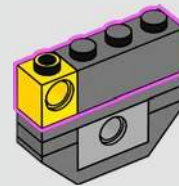

185

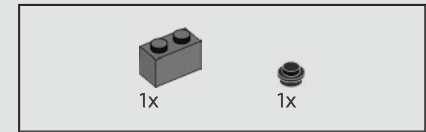
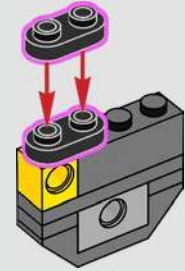

186

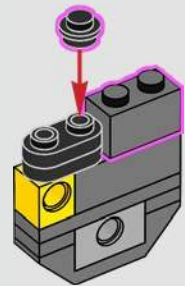



187

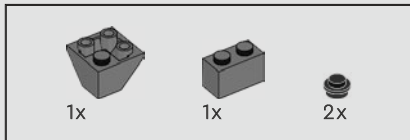
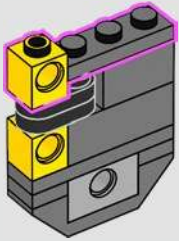

188

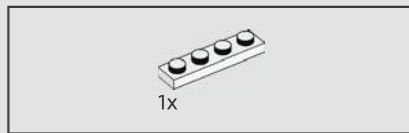
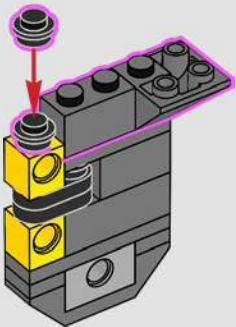

189

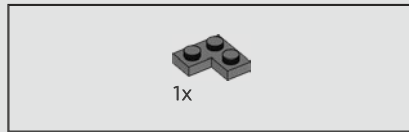
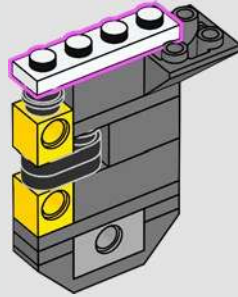

190

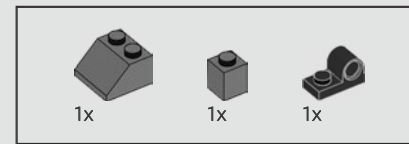
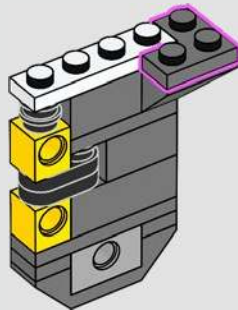

191

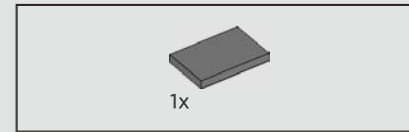
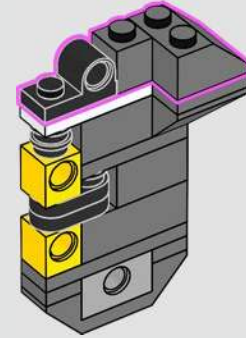

192

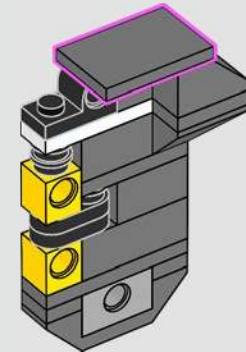

193

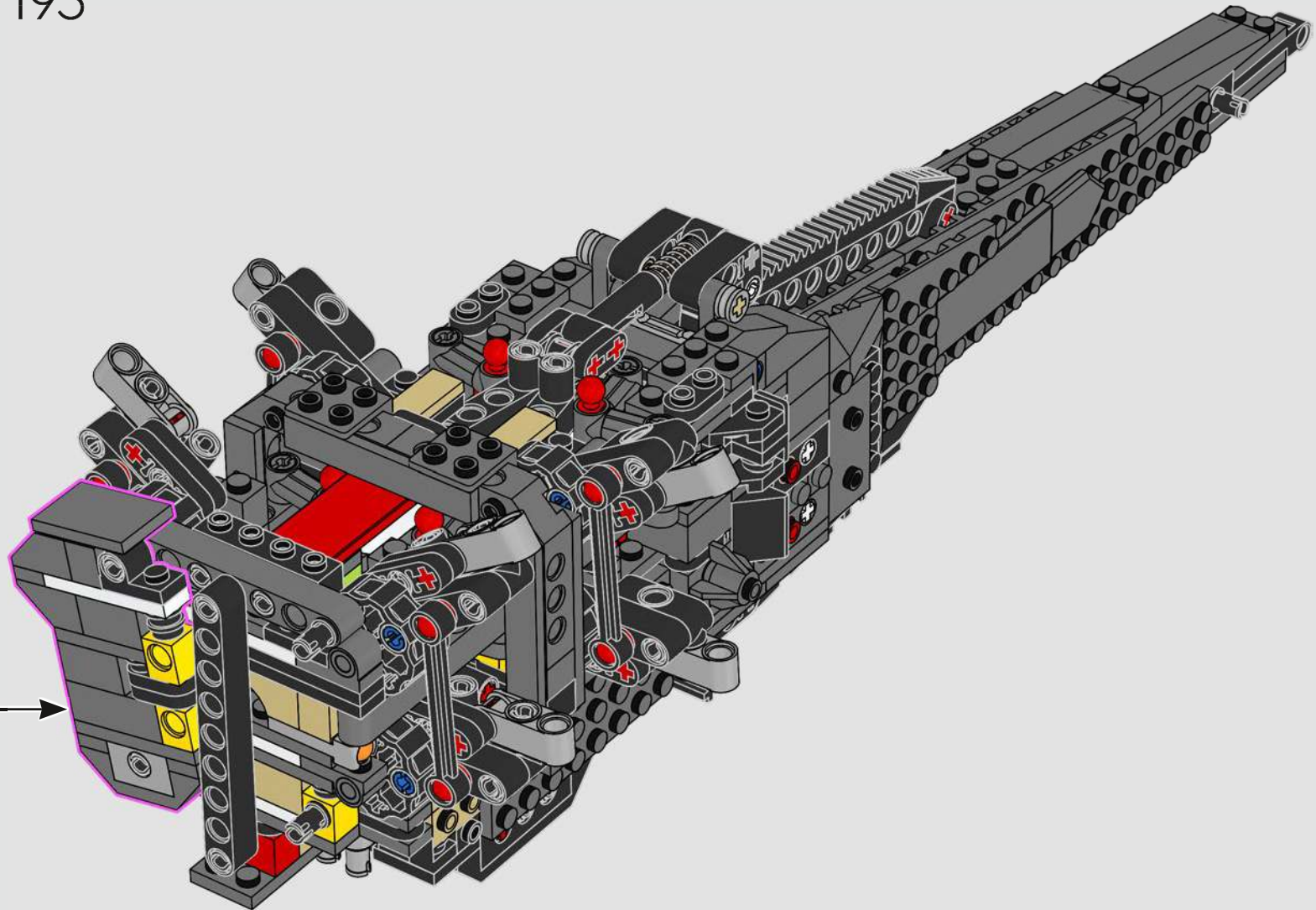

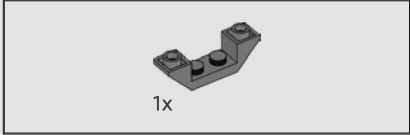
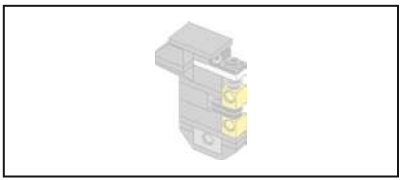

194

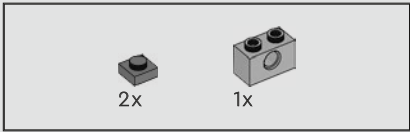
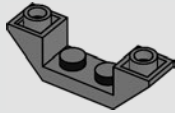

195

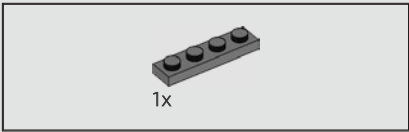
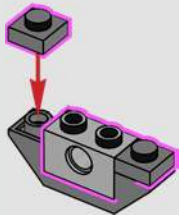

196

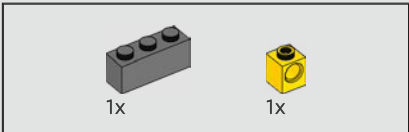
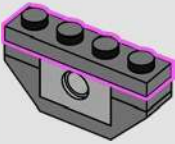

197

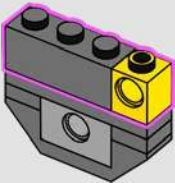



198

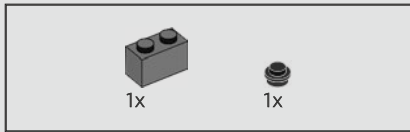
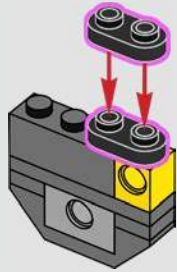

199

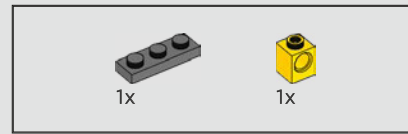
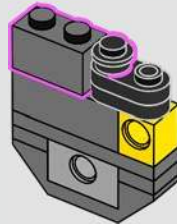

200

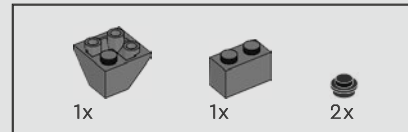
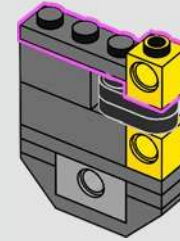

201

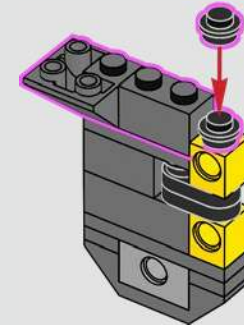

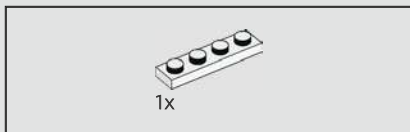

202

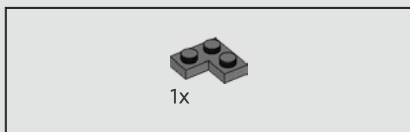
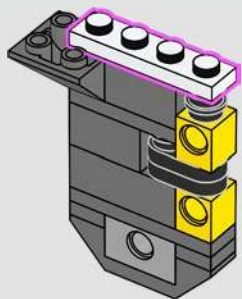

203

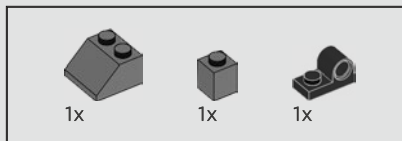
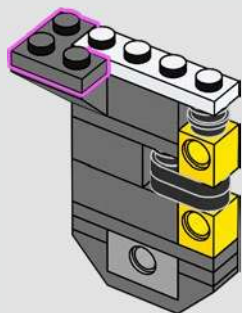

204

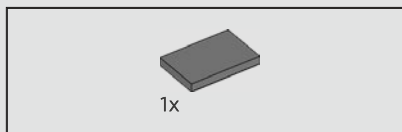
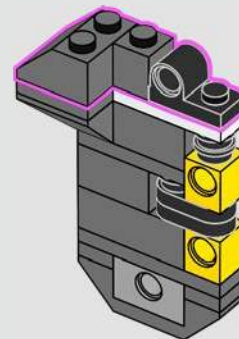

205

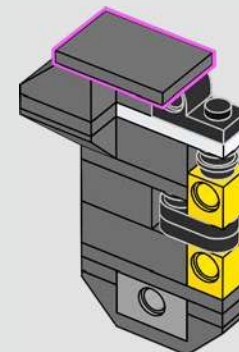

206

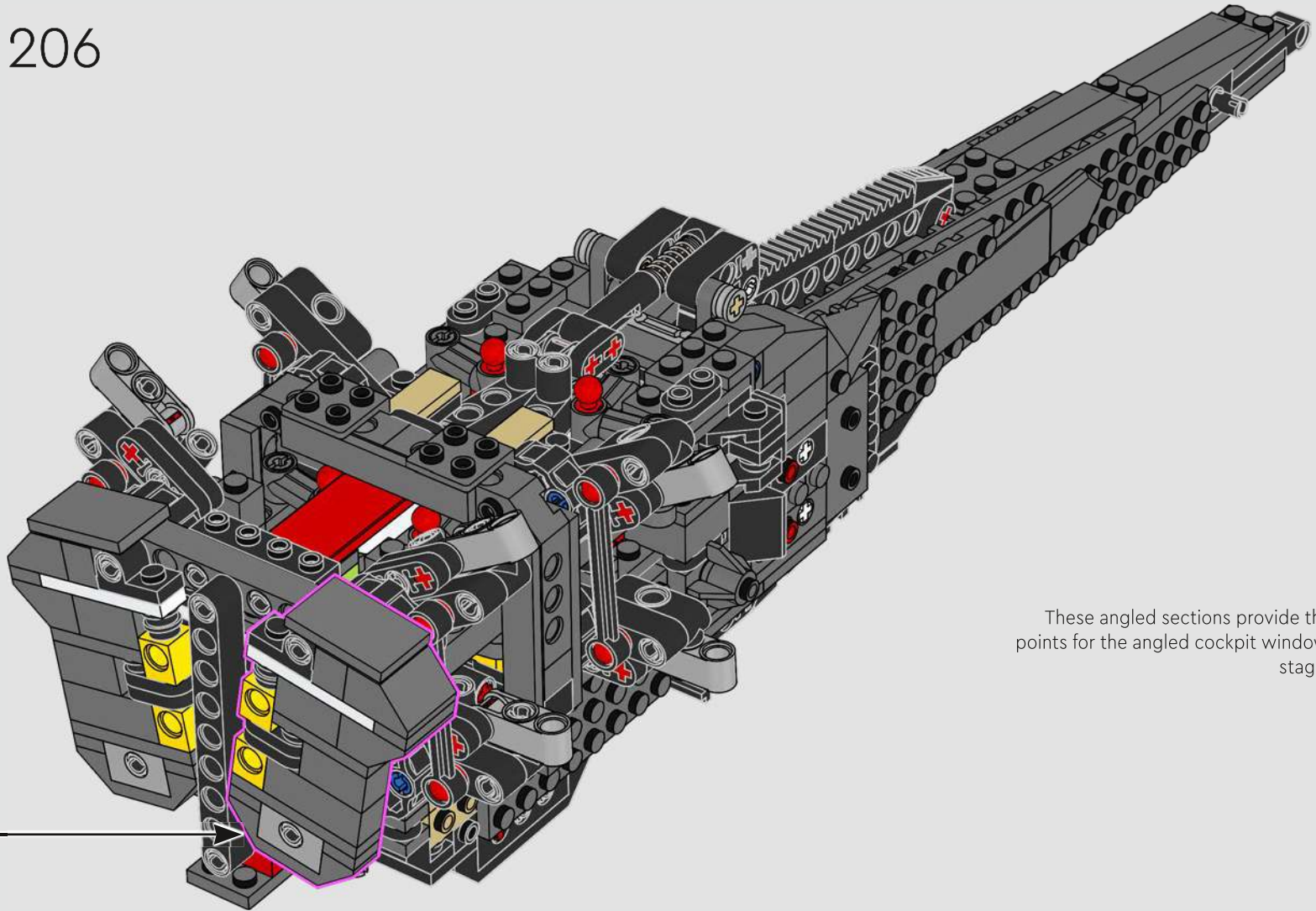

These angled sections provide the connection points for the angled cockpit windows in the next stage of the build.



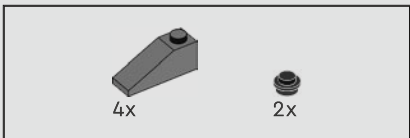

207

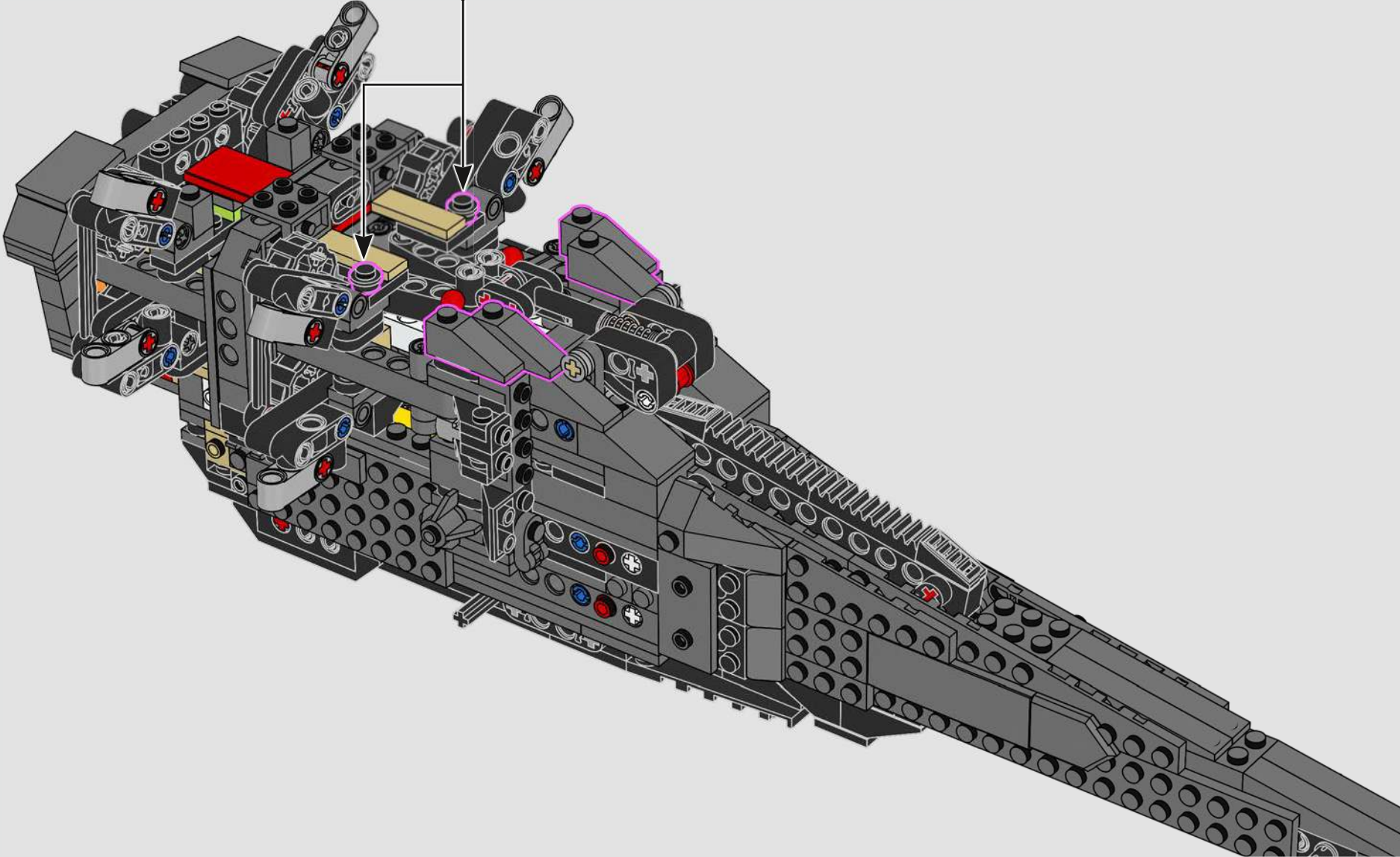

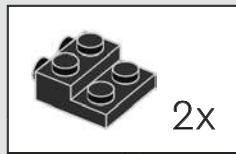
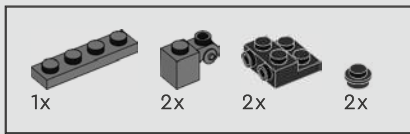

208

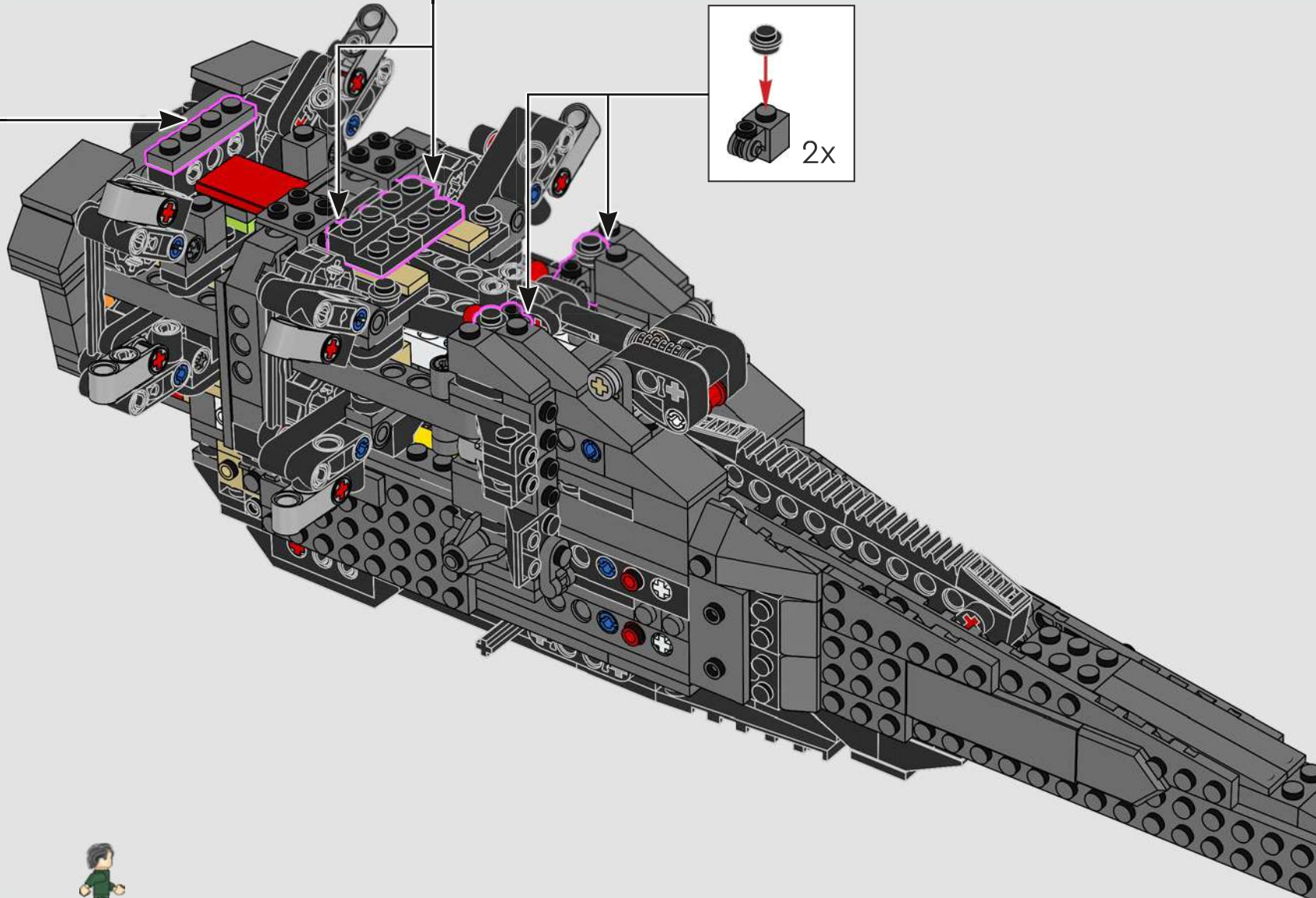
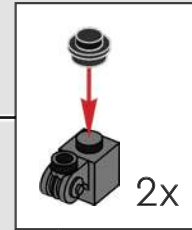
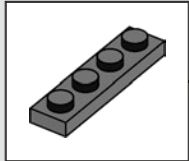

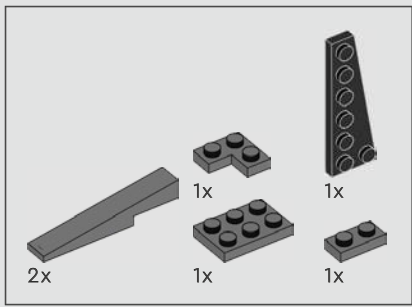

209

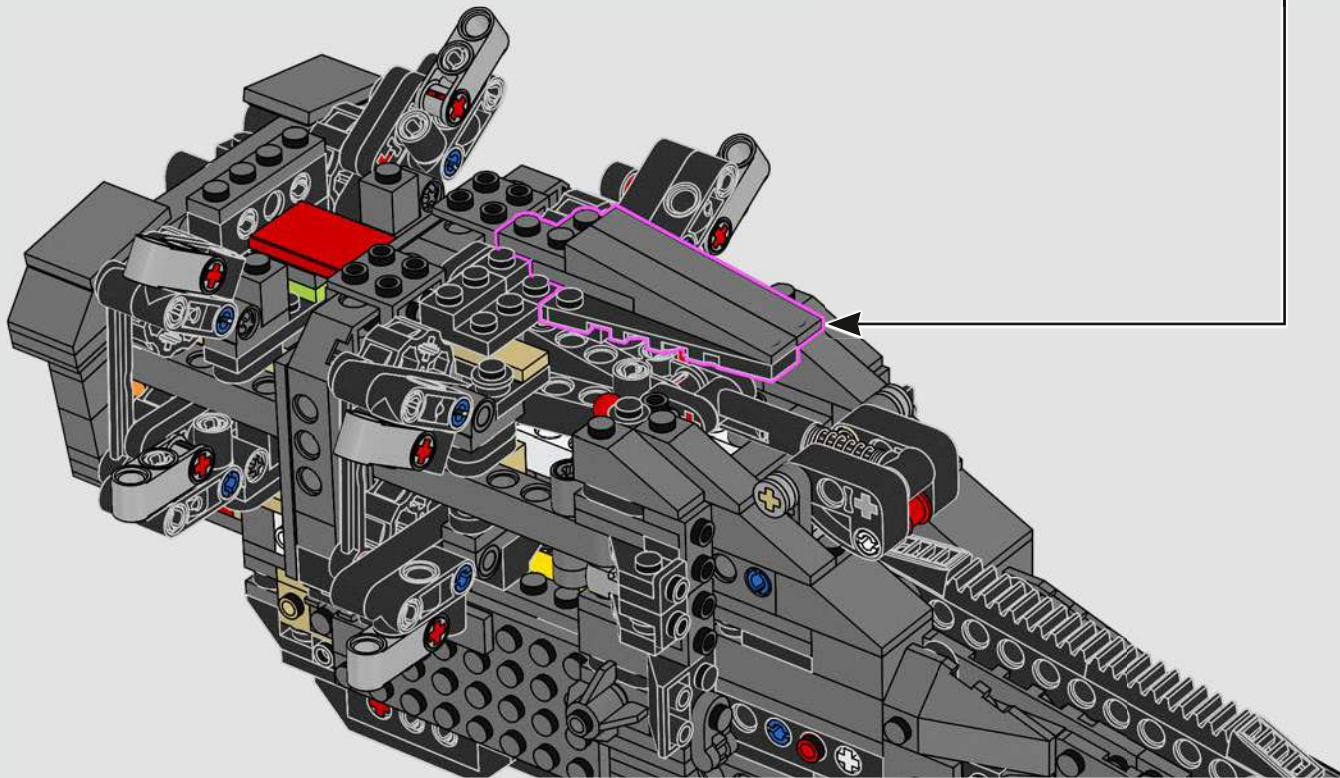
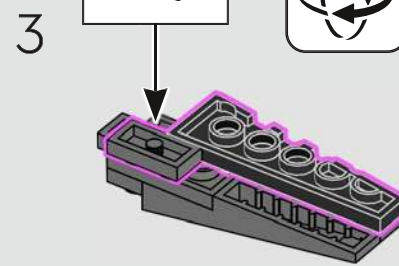
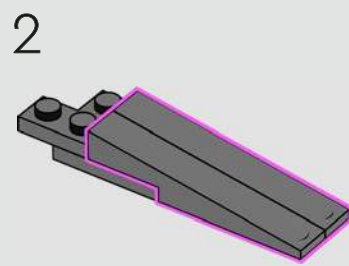
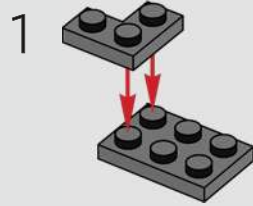

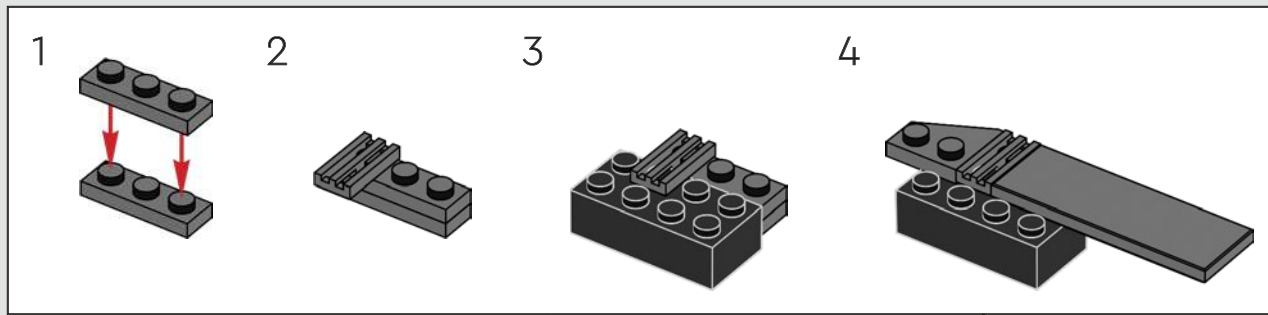
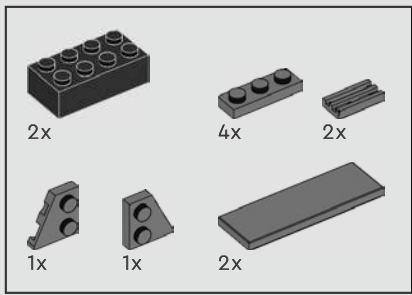

211

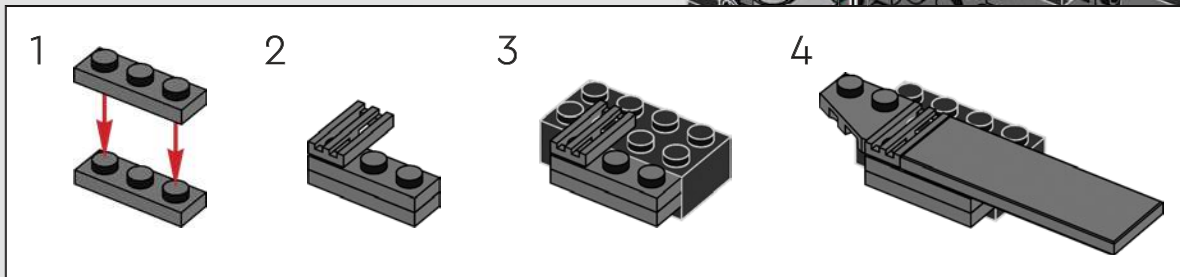
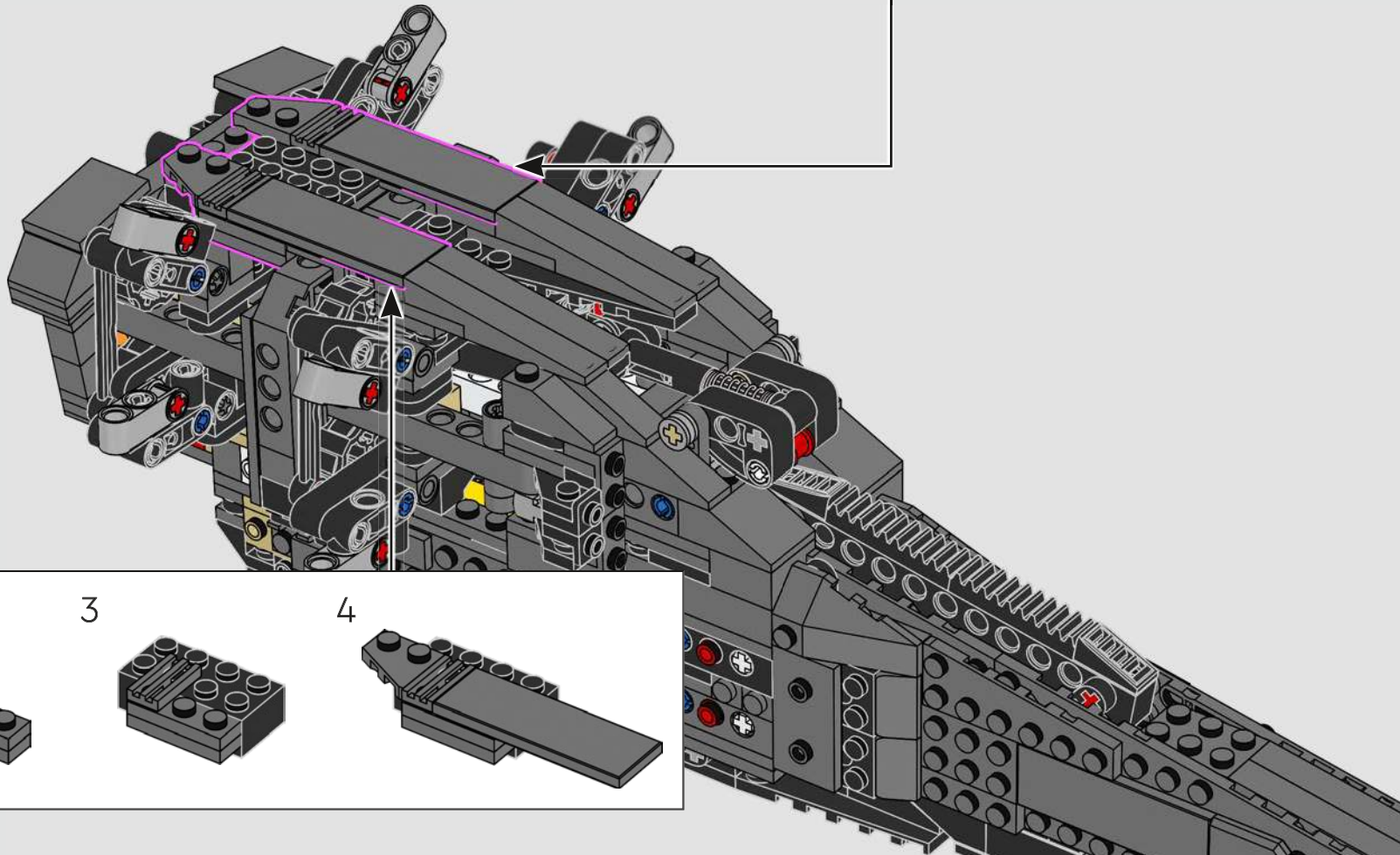

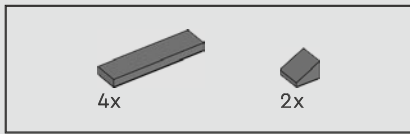

212

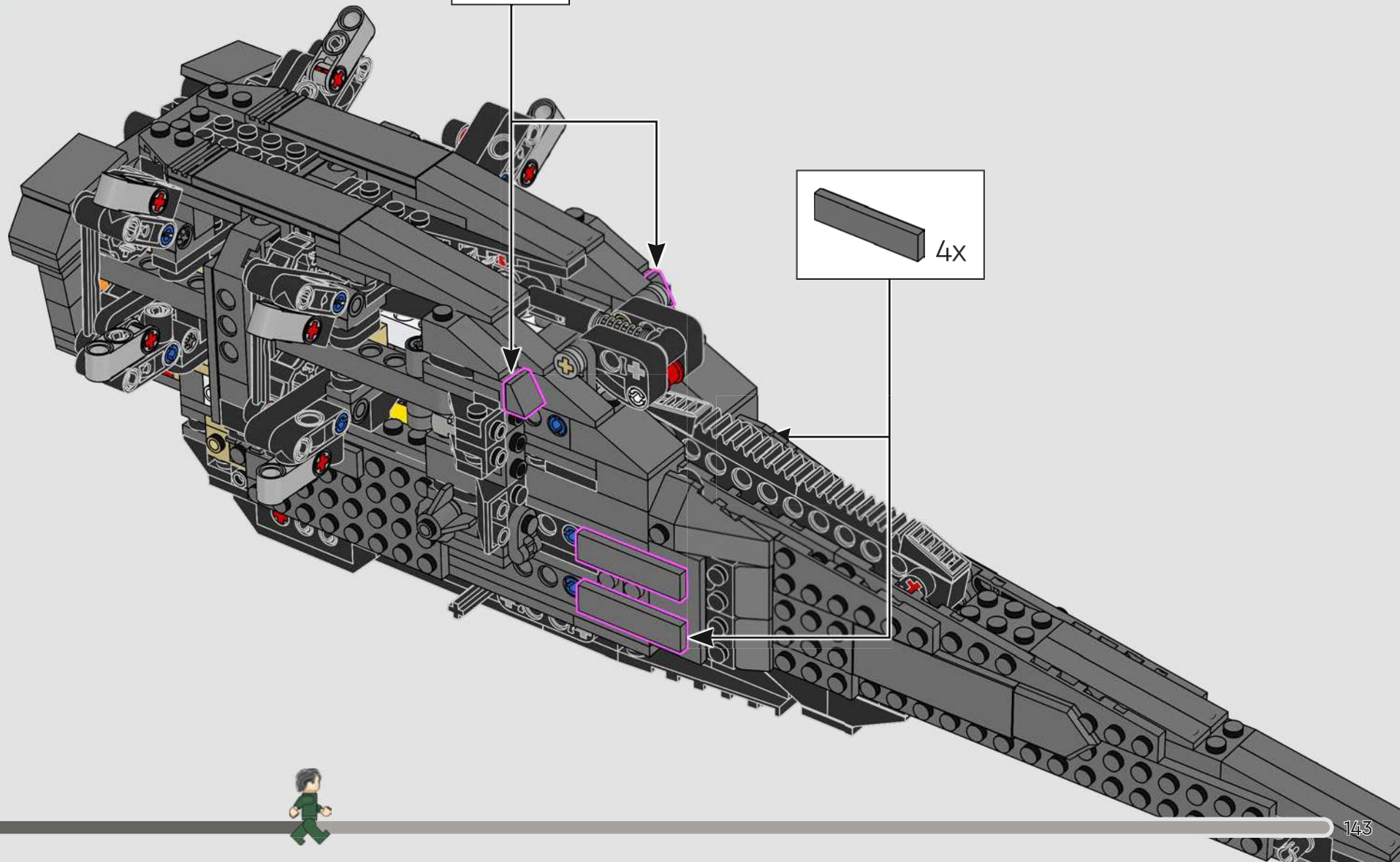
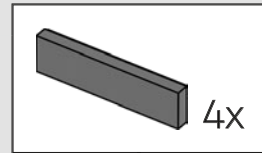

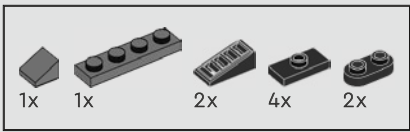

213

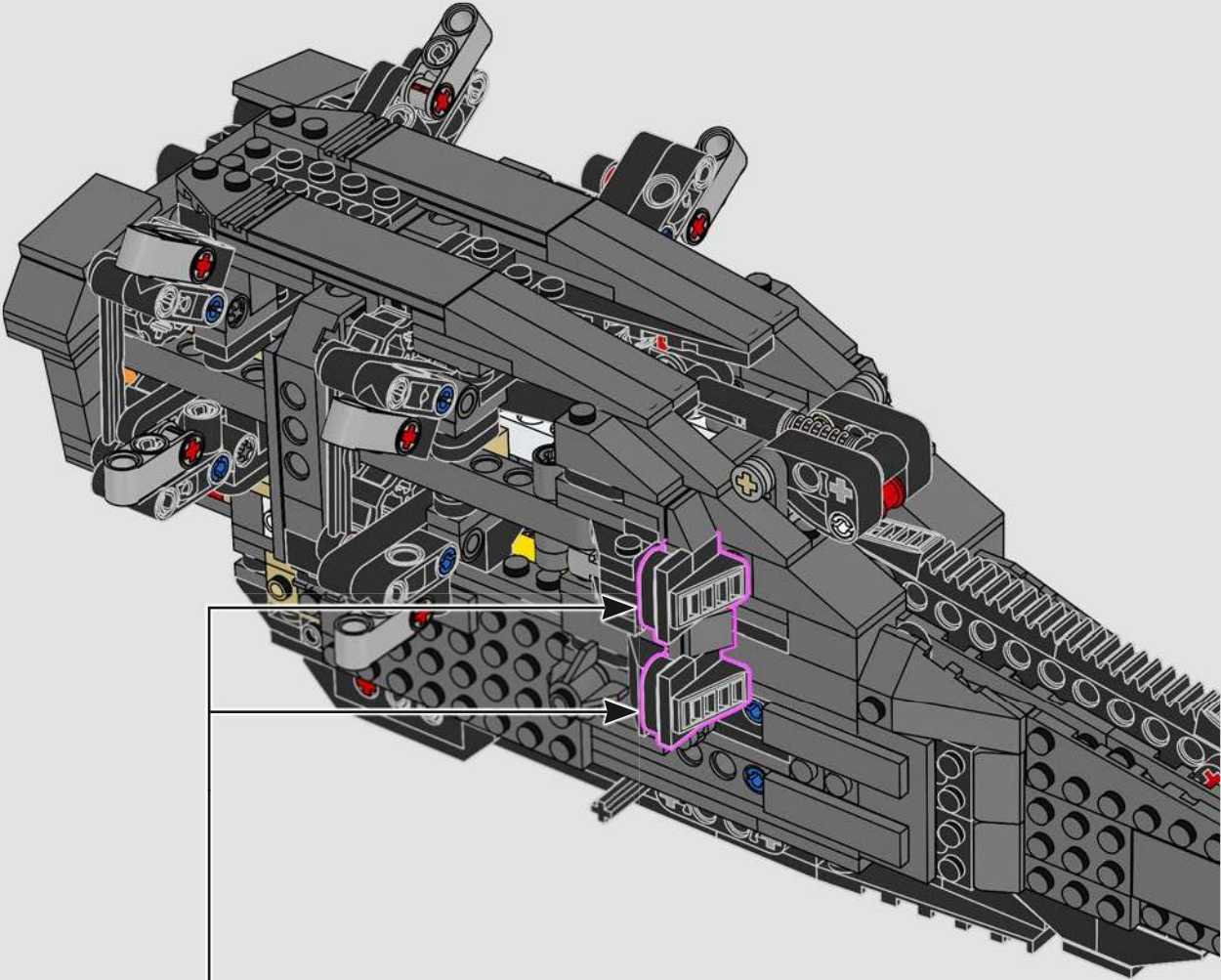
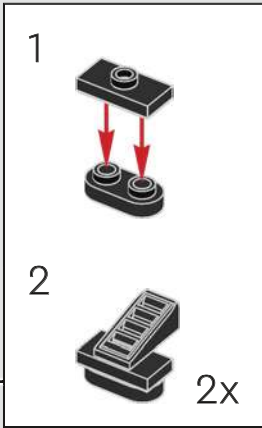
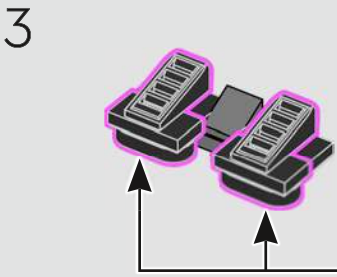
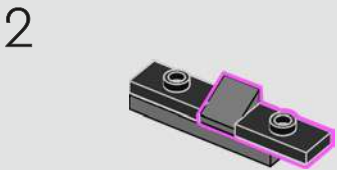
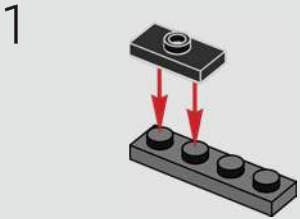

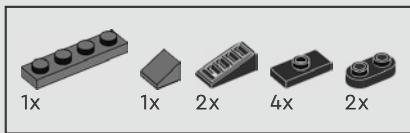

214

1

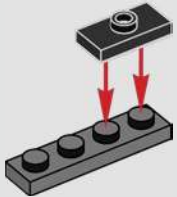

2

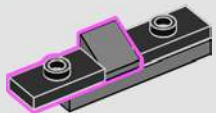

3

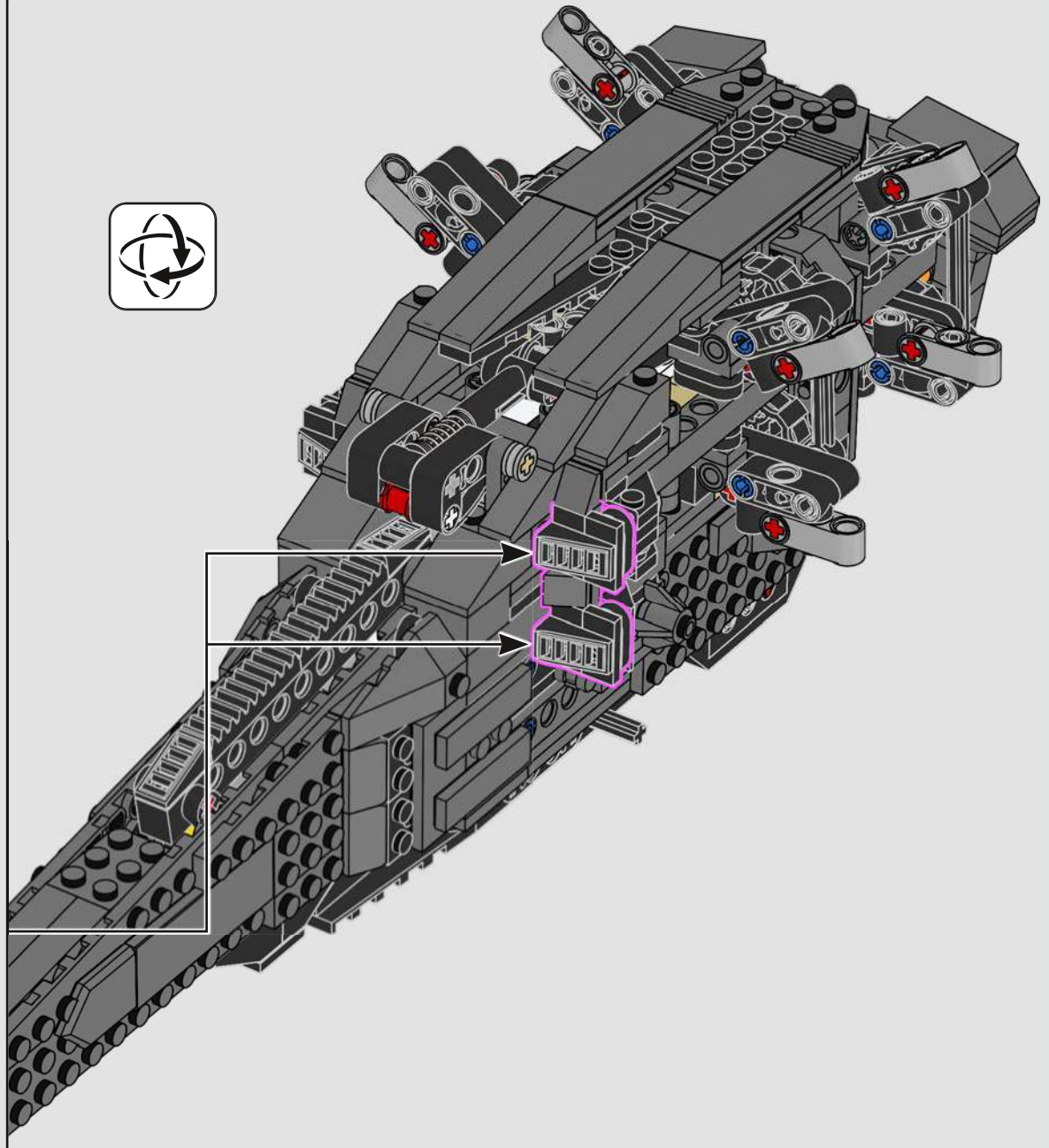
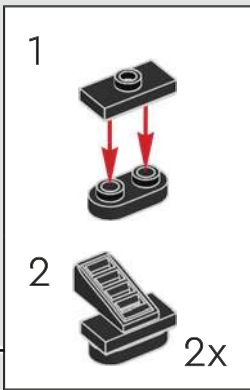
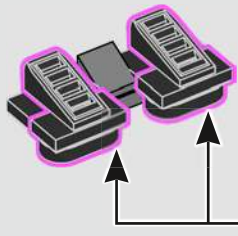

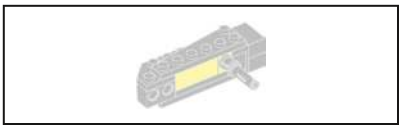

215

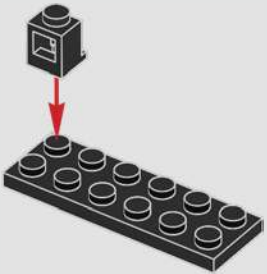

216

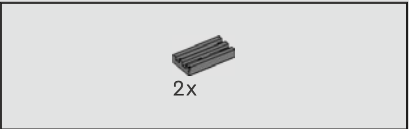
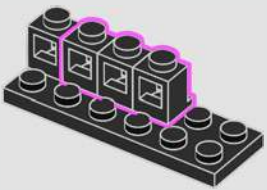

217

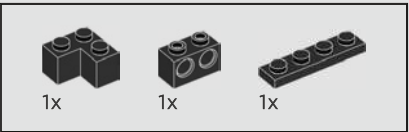
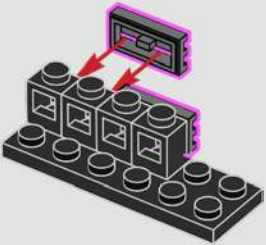

218

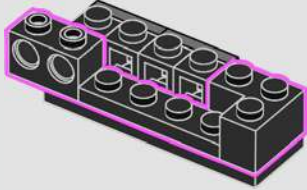

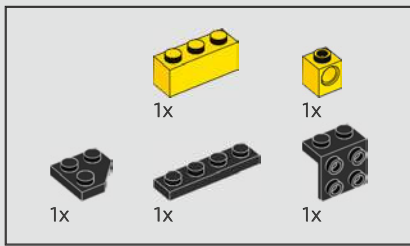

219

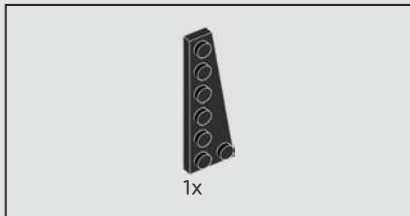
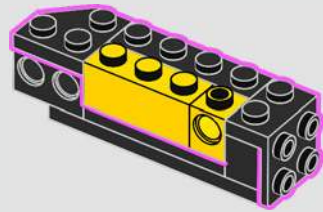

220

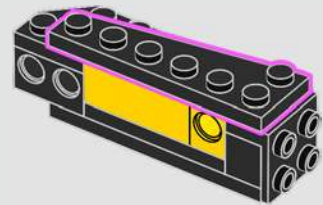

221

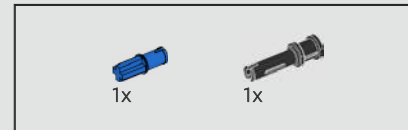
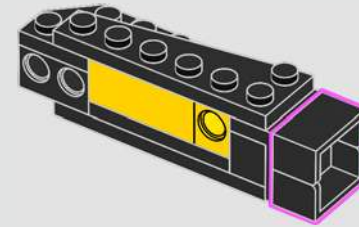

222

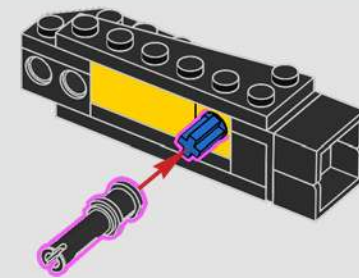

223

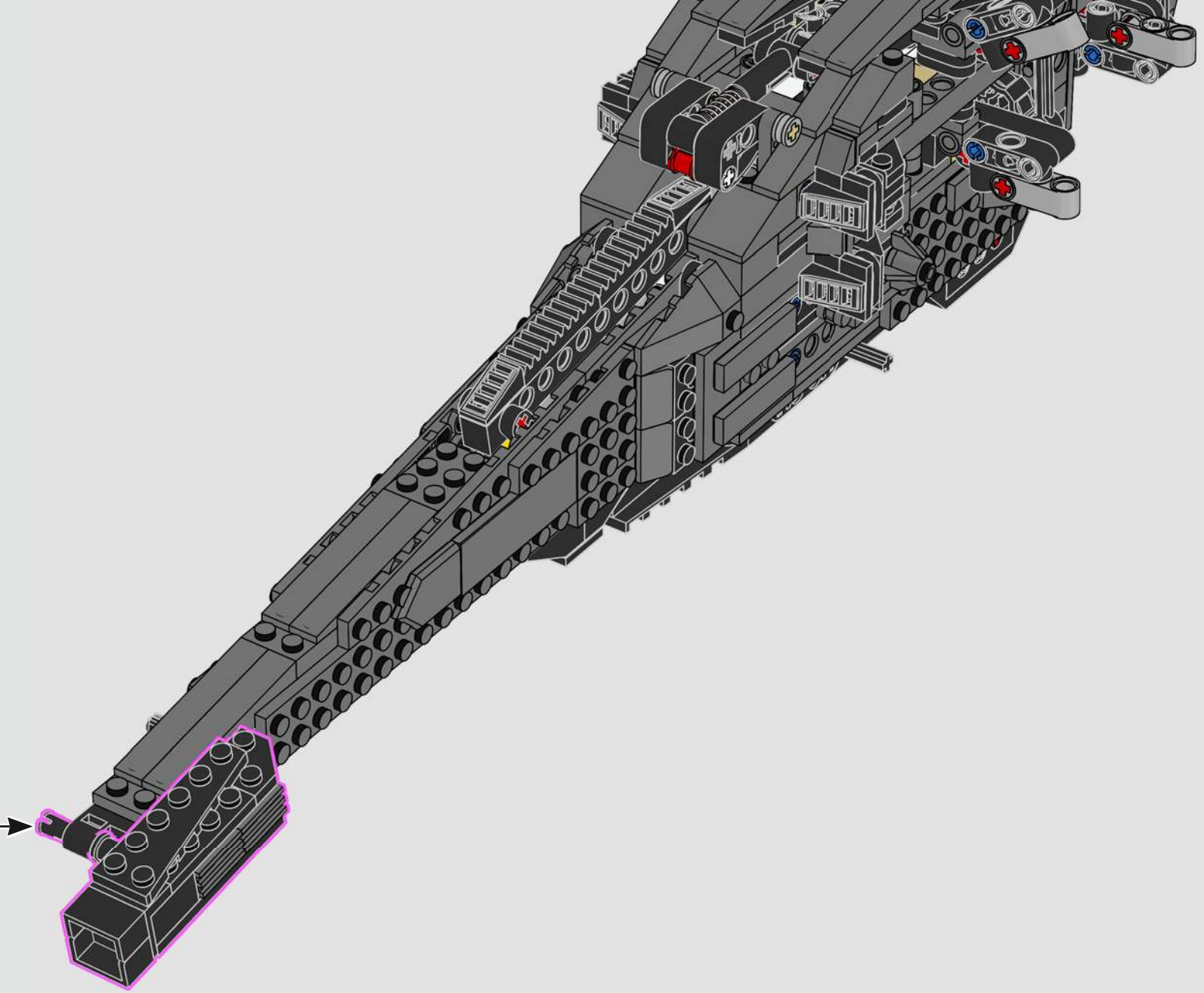

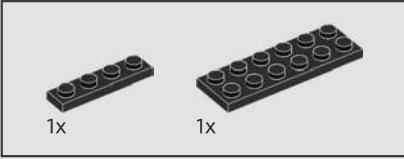
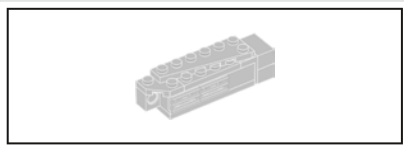

224

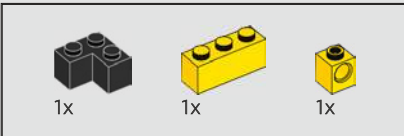
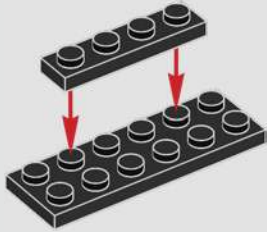

225

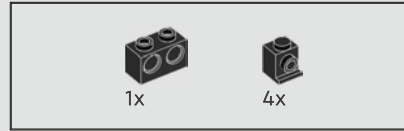
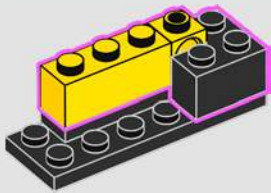

226

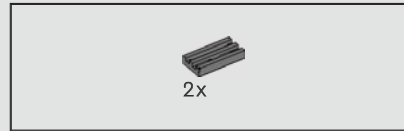
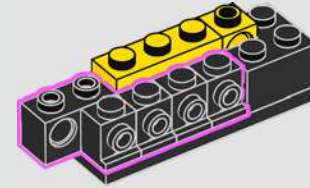

227

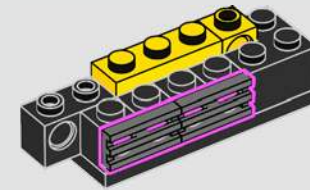

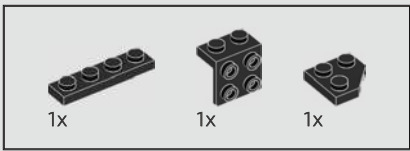

228

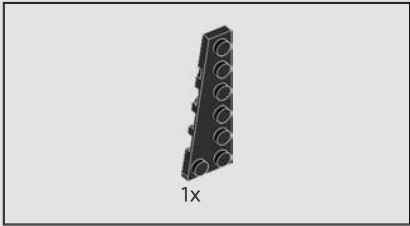
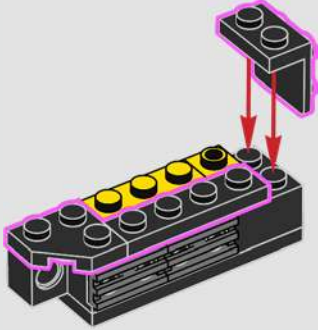

229

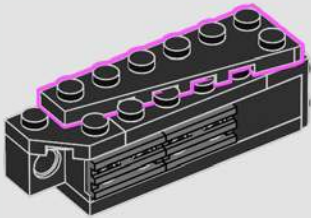

230

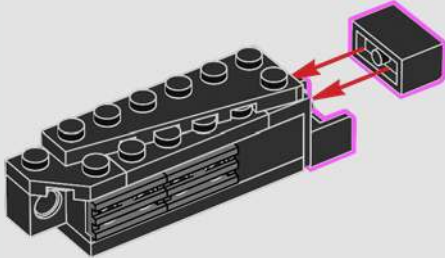

231

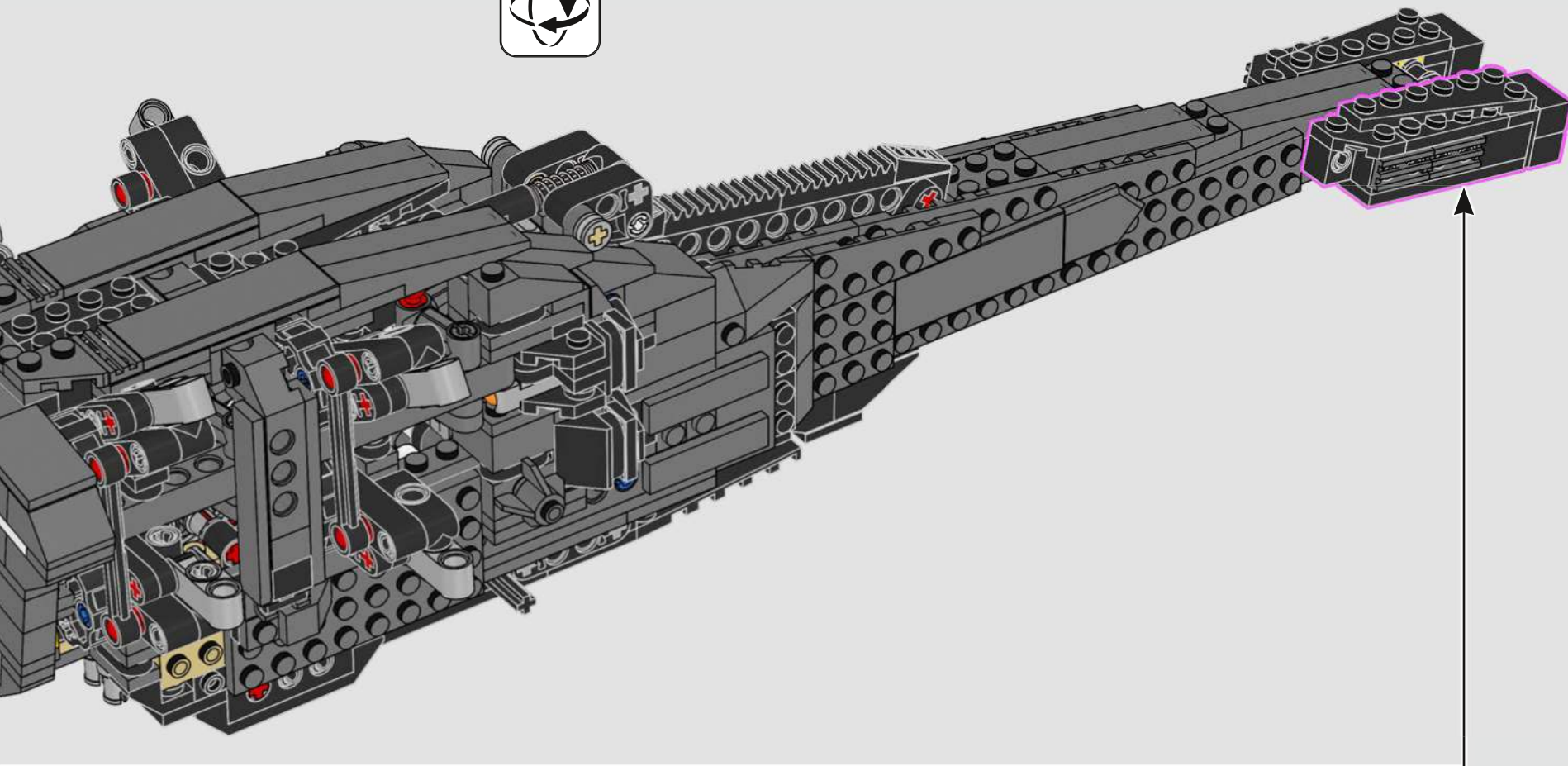

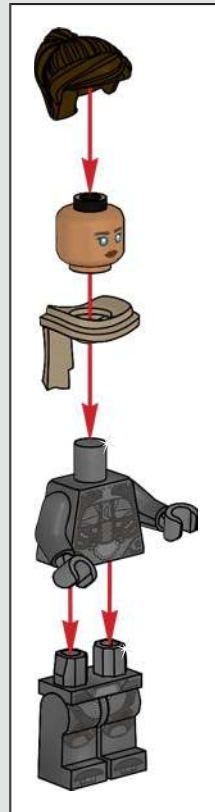

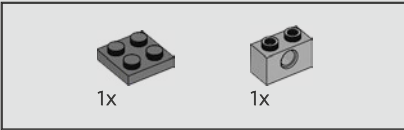
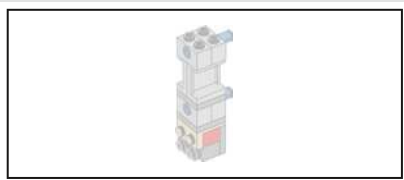

232

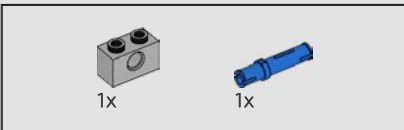
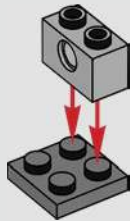

233

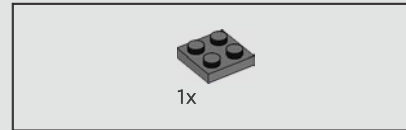
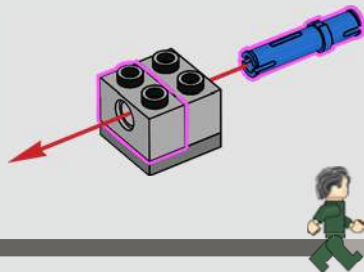

234

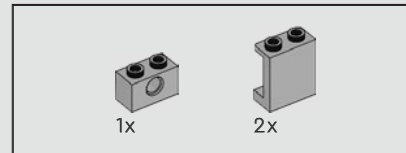
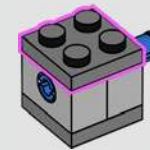

235

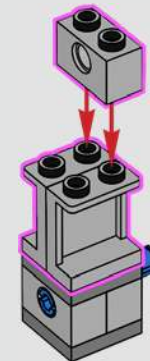

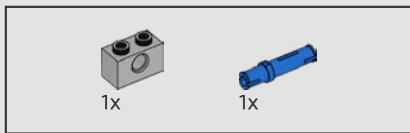

236

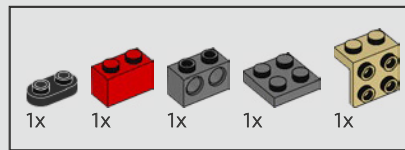
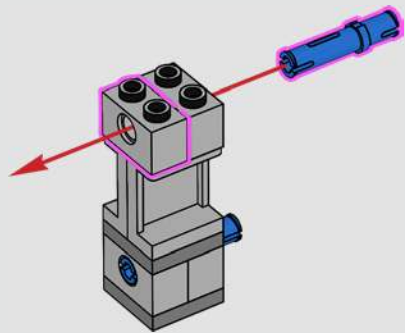

237

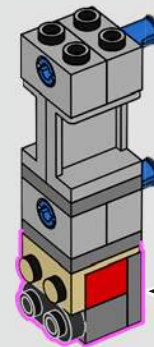
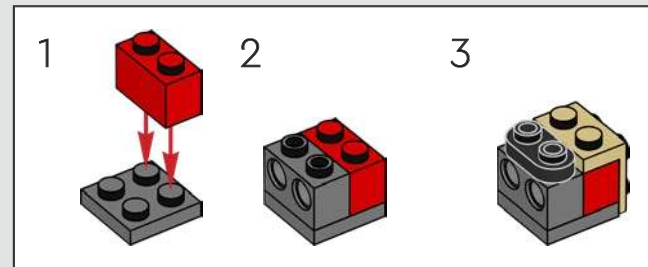

238

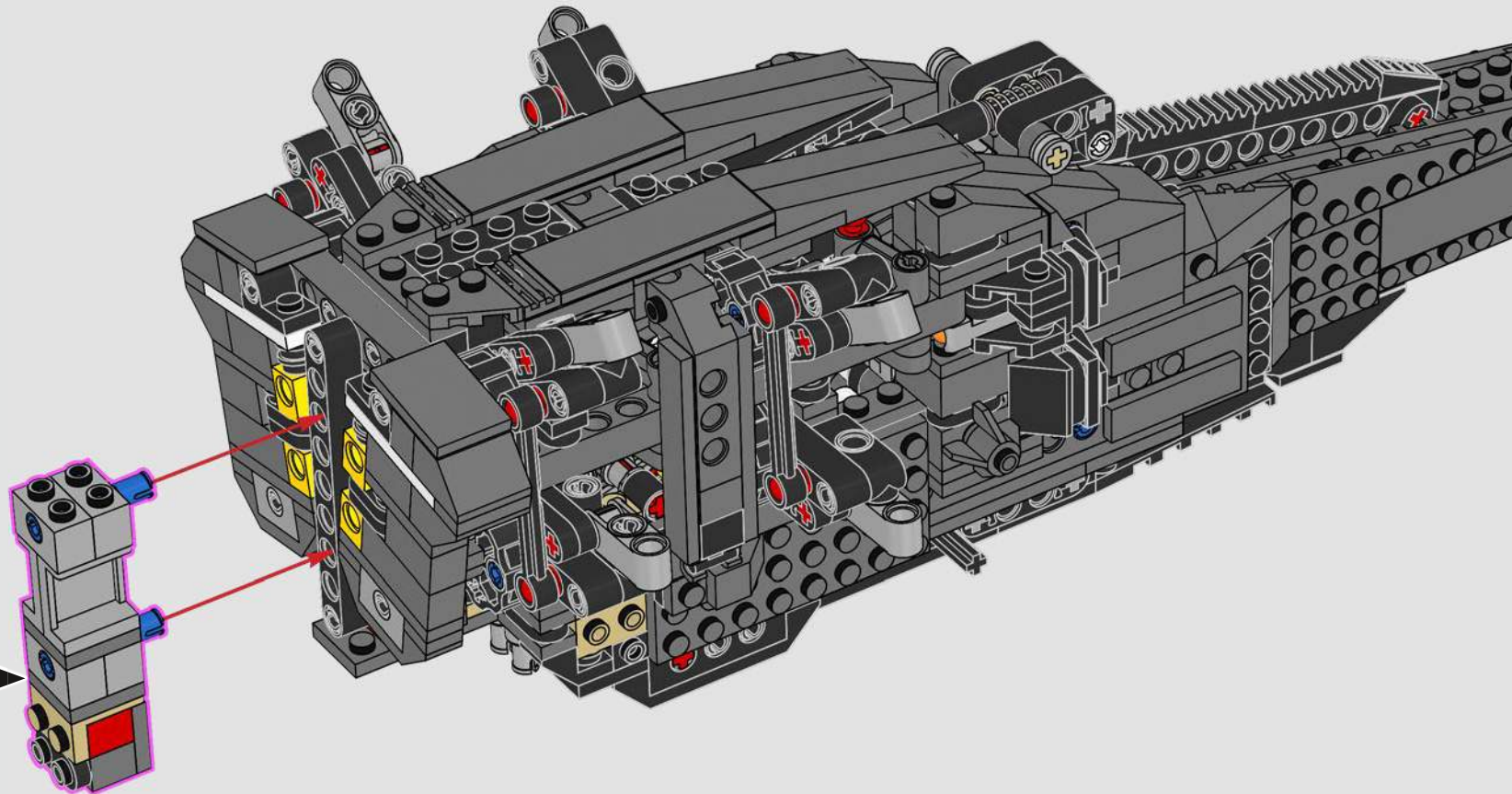

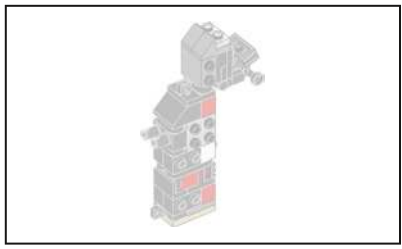

239

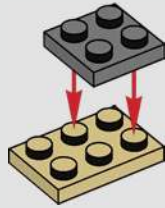

240

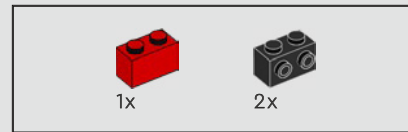
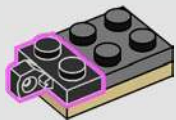

241

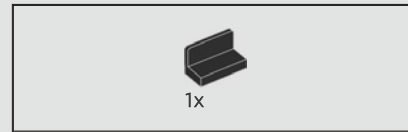
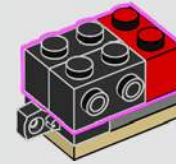

242

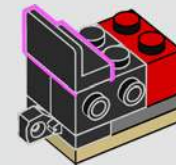

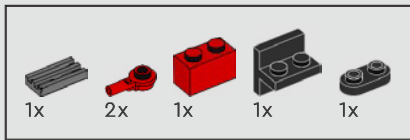

243

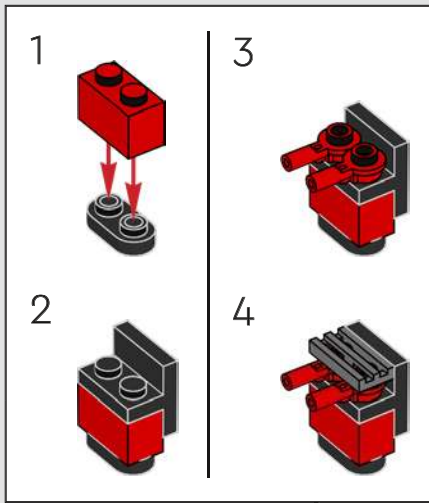
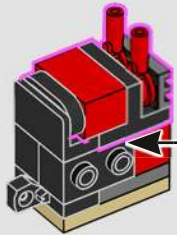

244



245

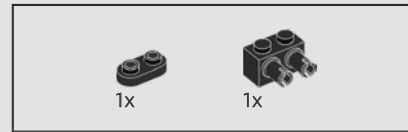
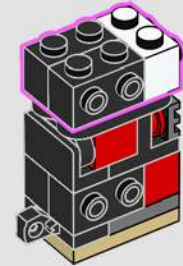

246

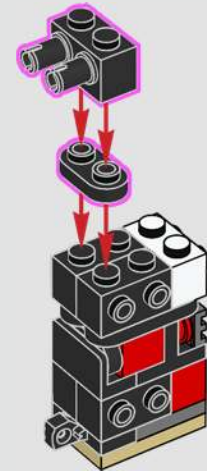

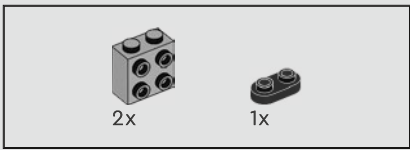

247

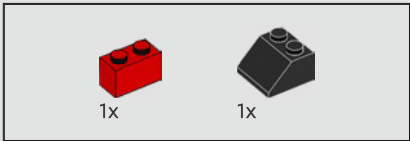
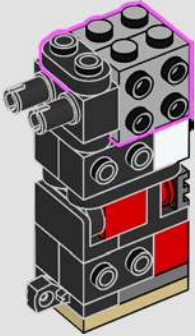

248

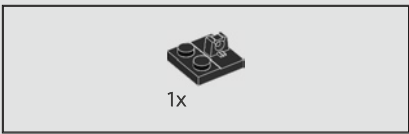
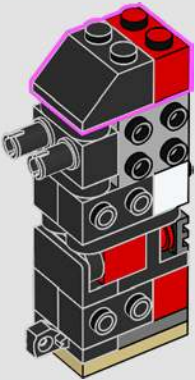

249

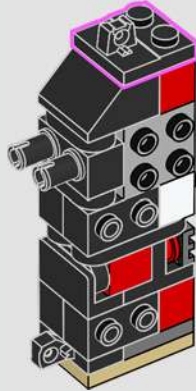

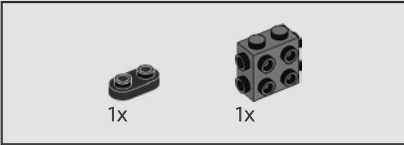

250

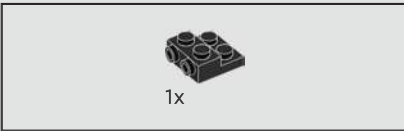
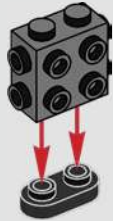

251

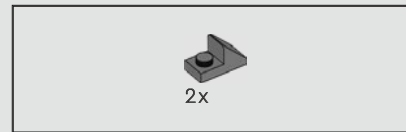
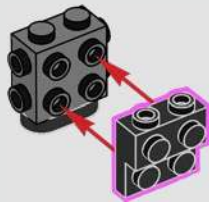

252

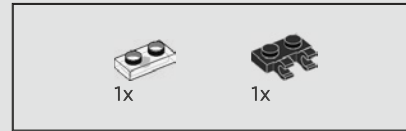
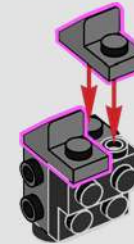

253

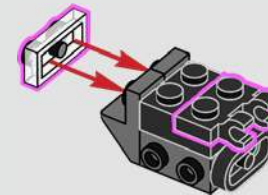

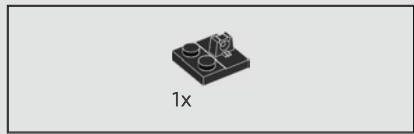

254

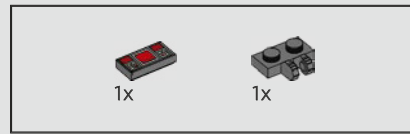

255

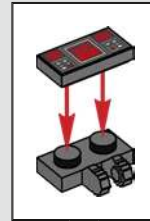

256

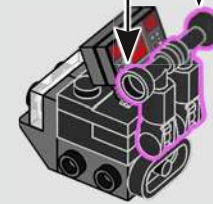
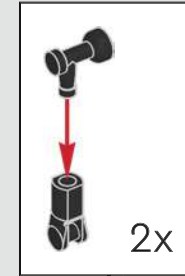

257

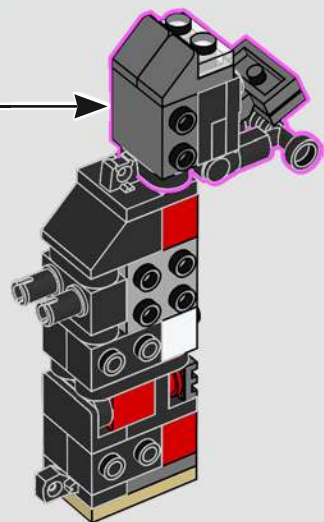

258

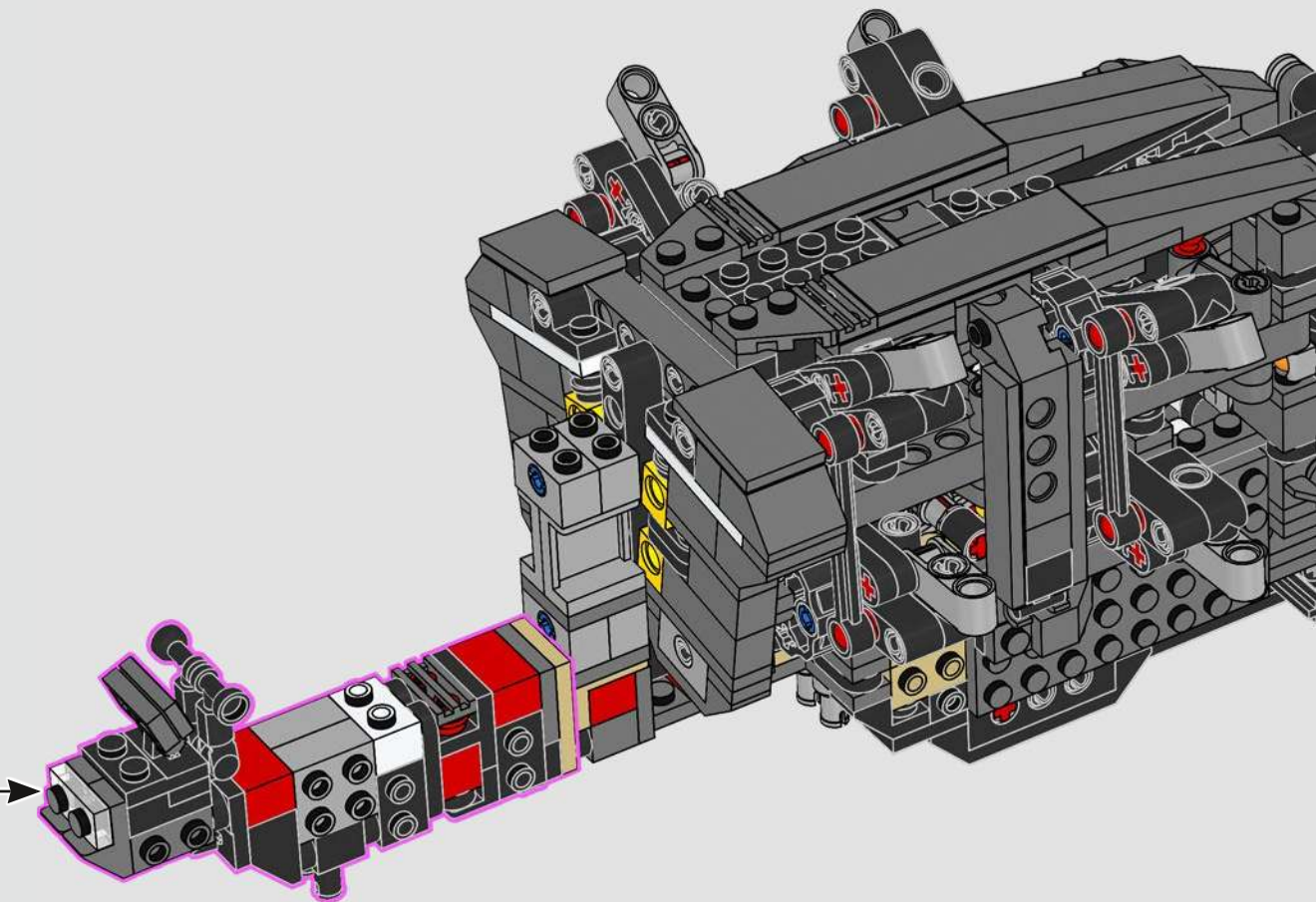

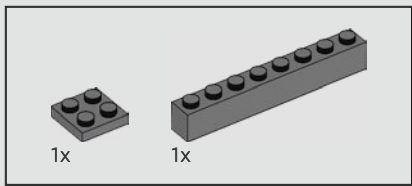

259

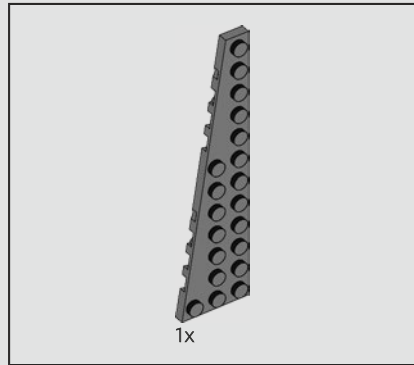
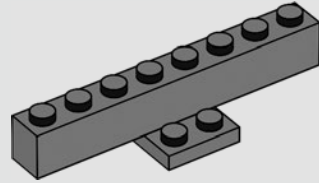

260

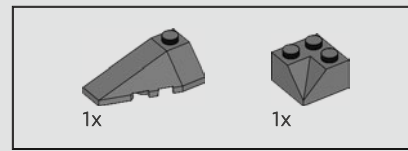
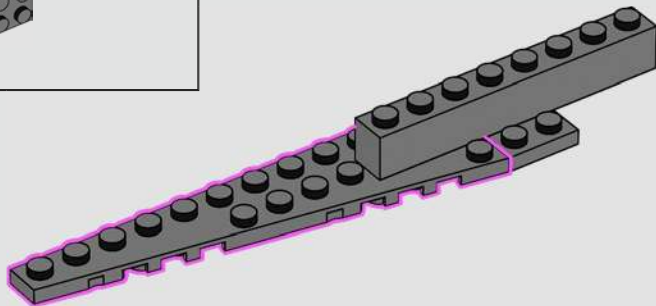

261

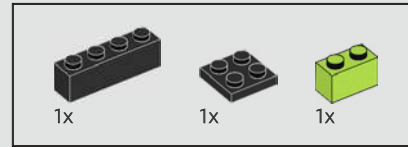
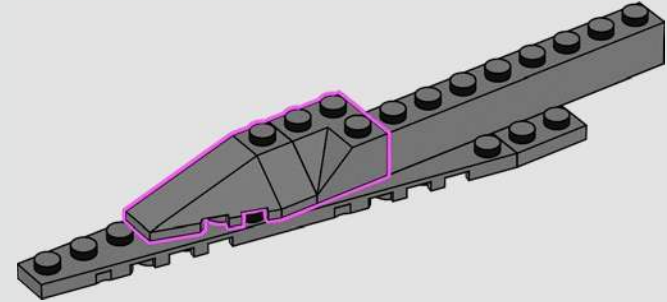

262

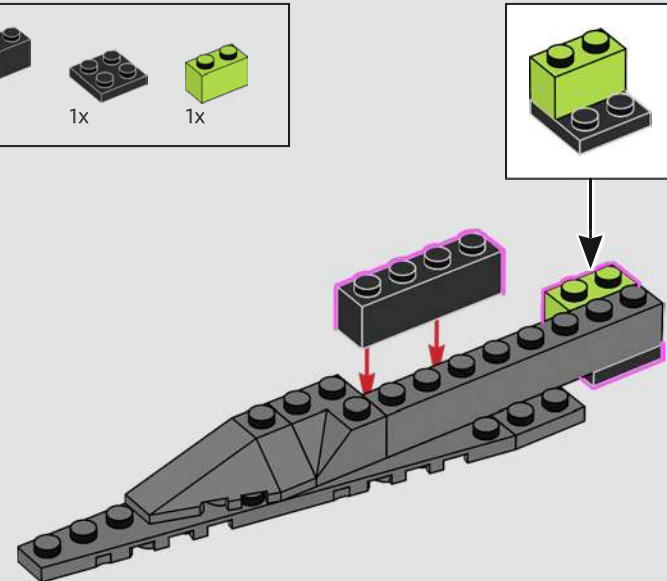

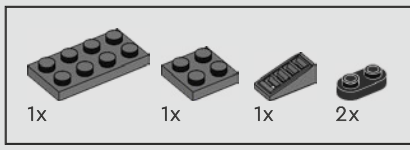

263

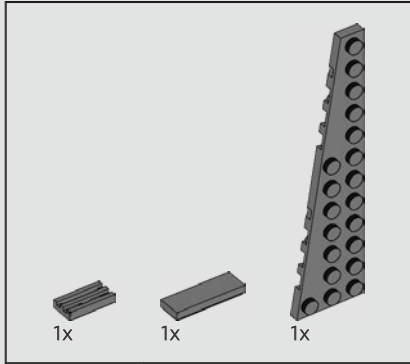
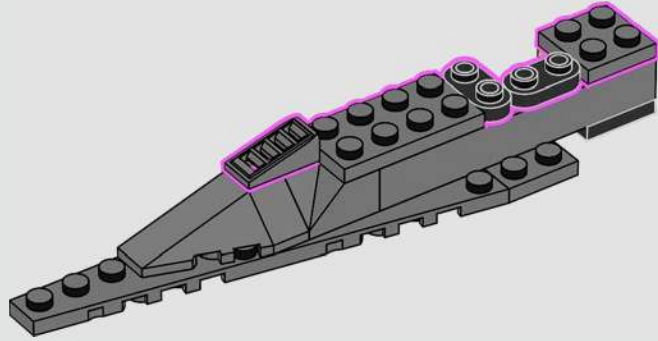

264

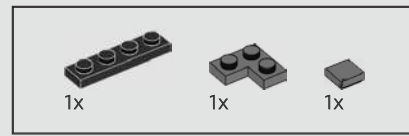
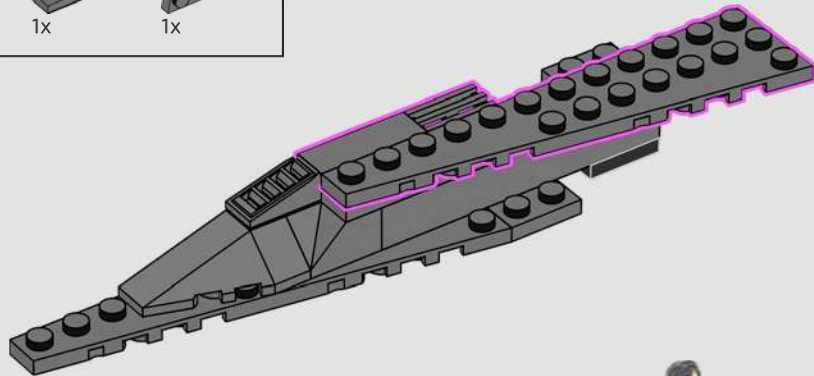

265

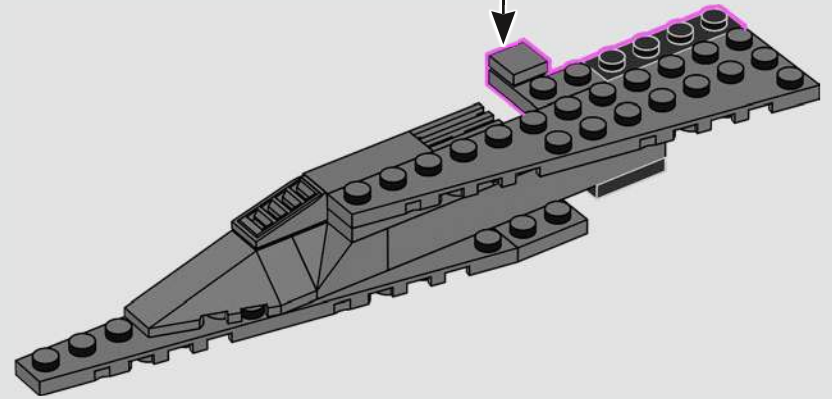
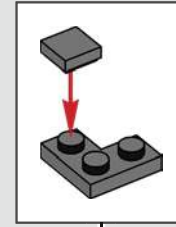

266

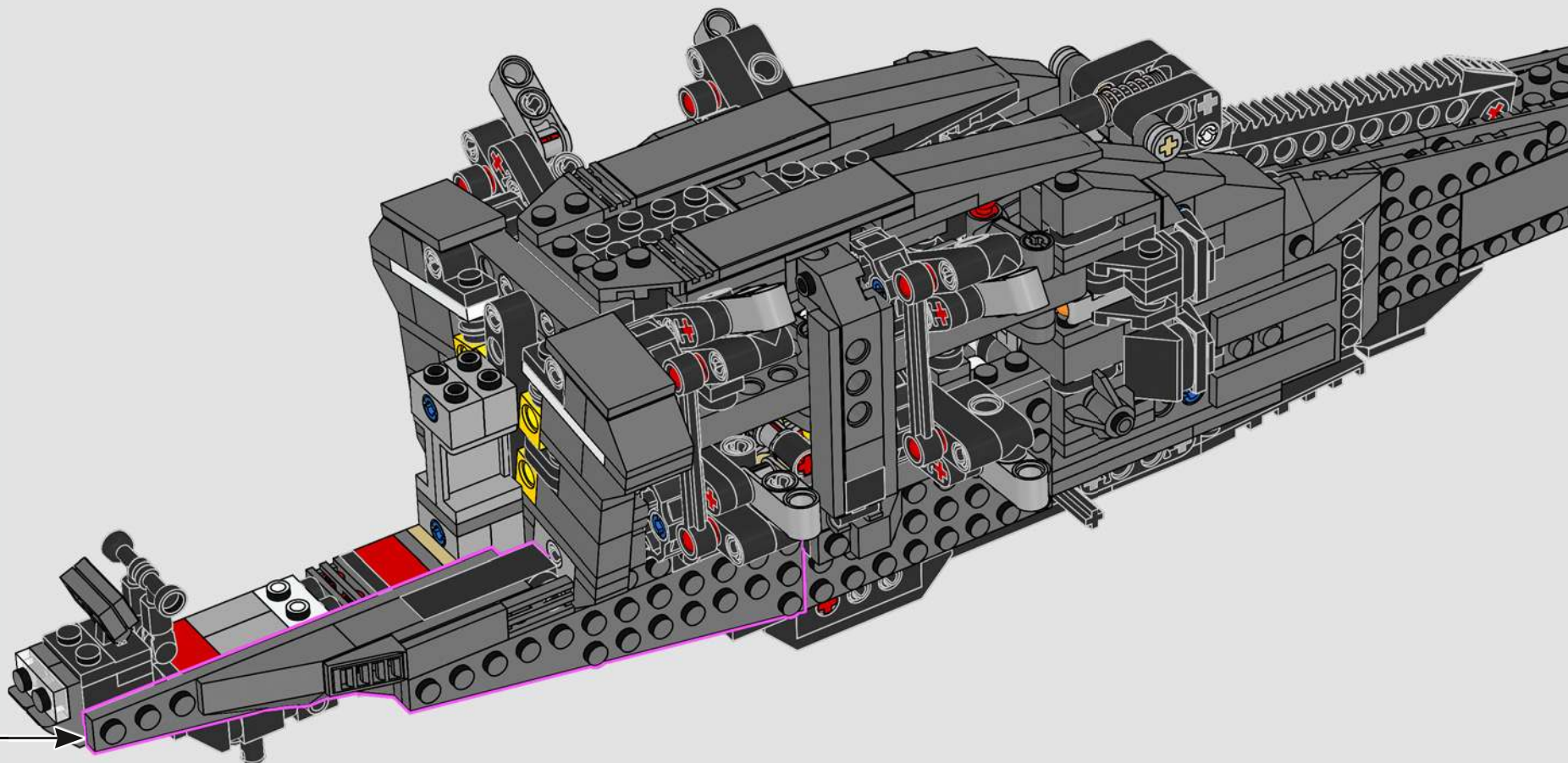

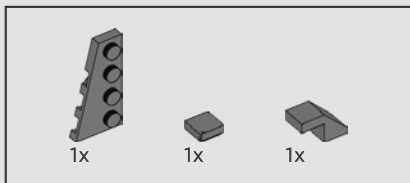

267

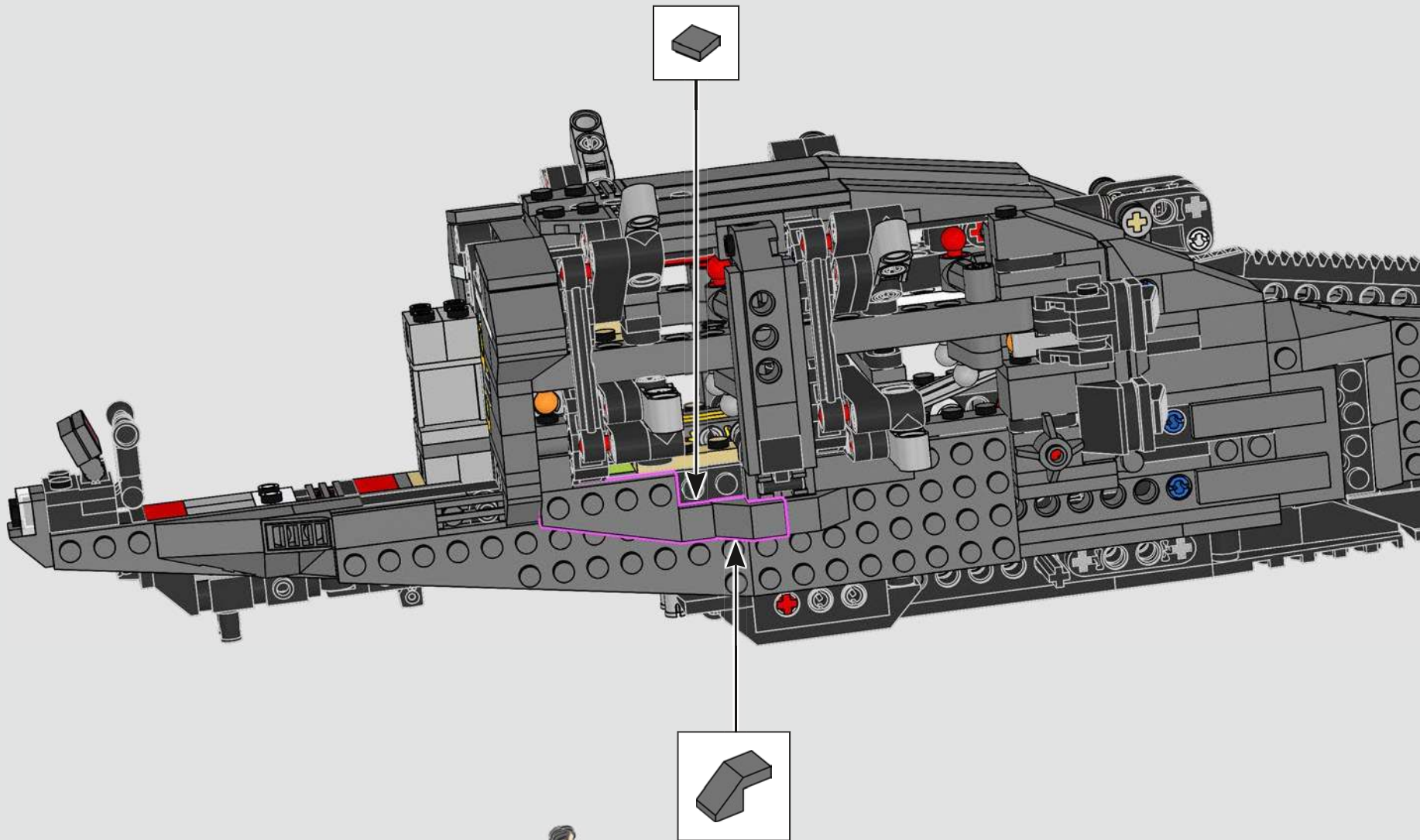

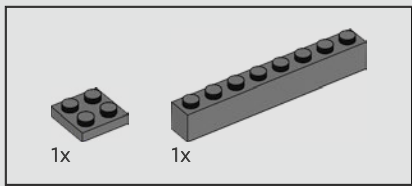

268

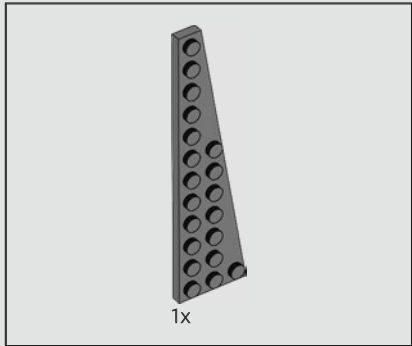
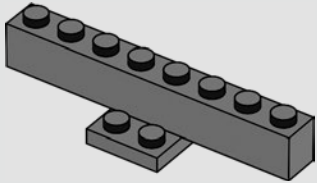

269

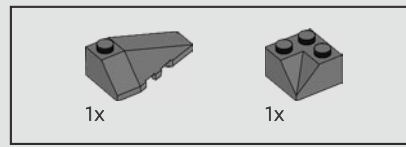
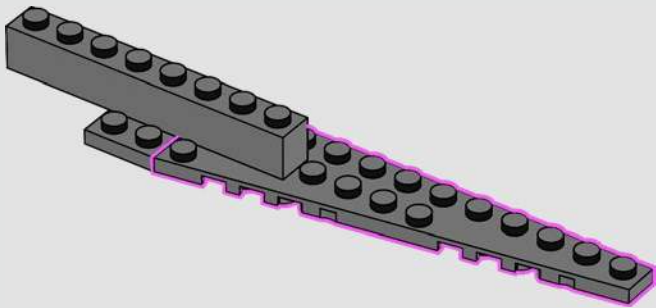

270

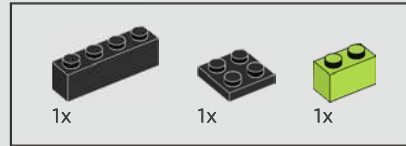
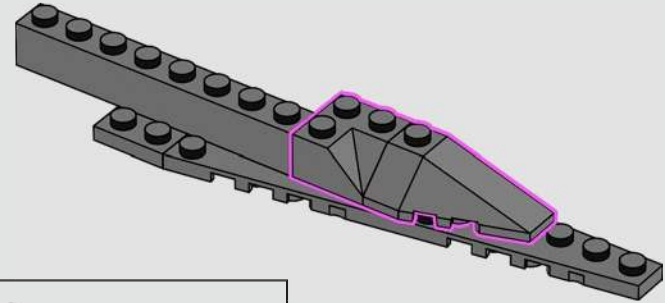

271

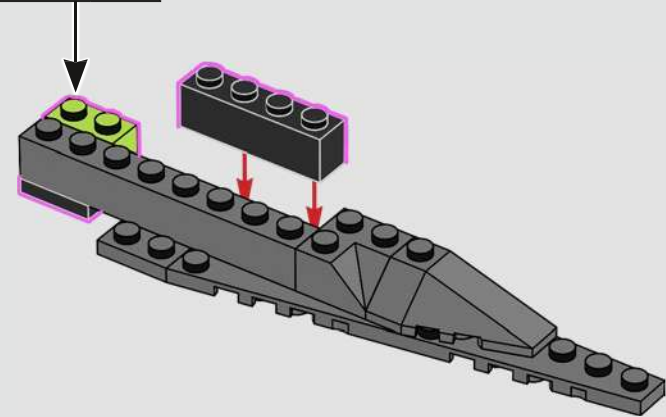
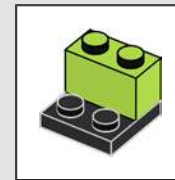

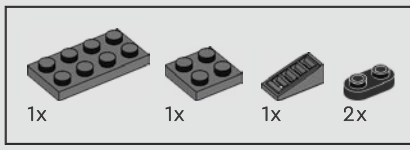

272

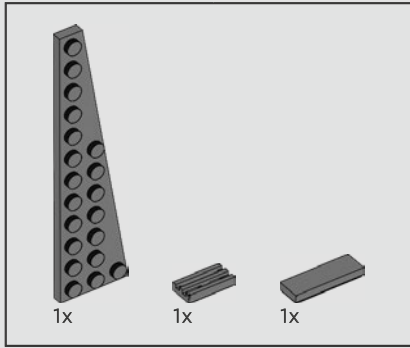
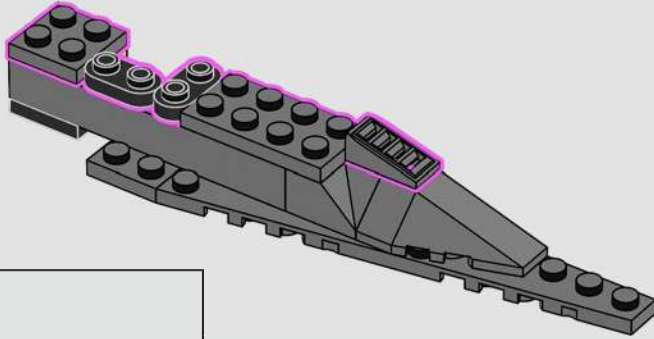

273

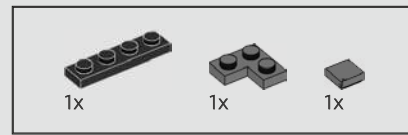
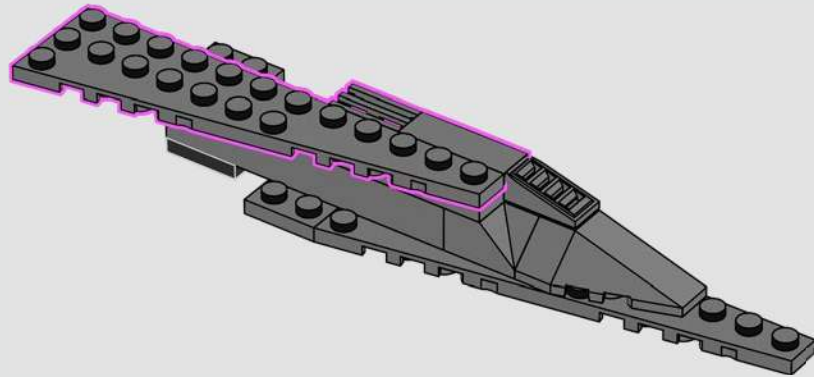

274

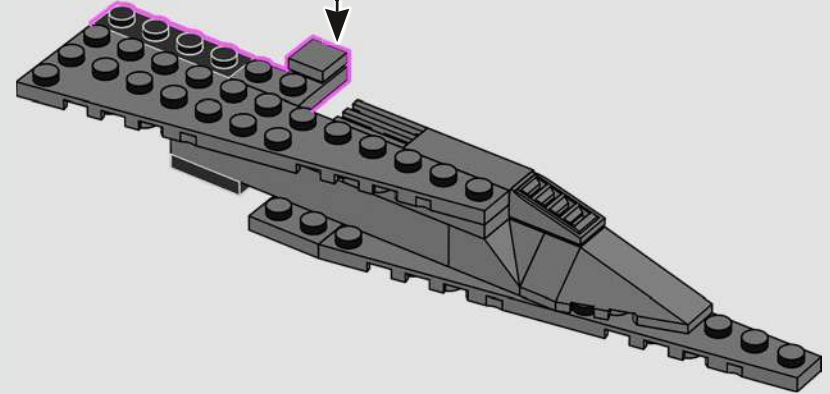
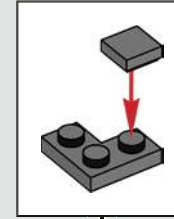

275

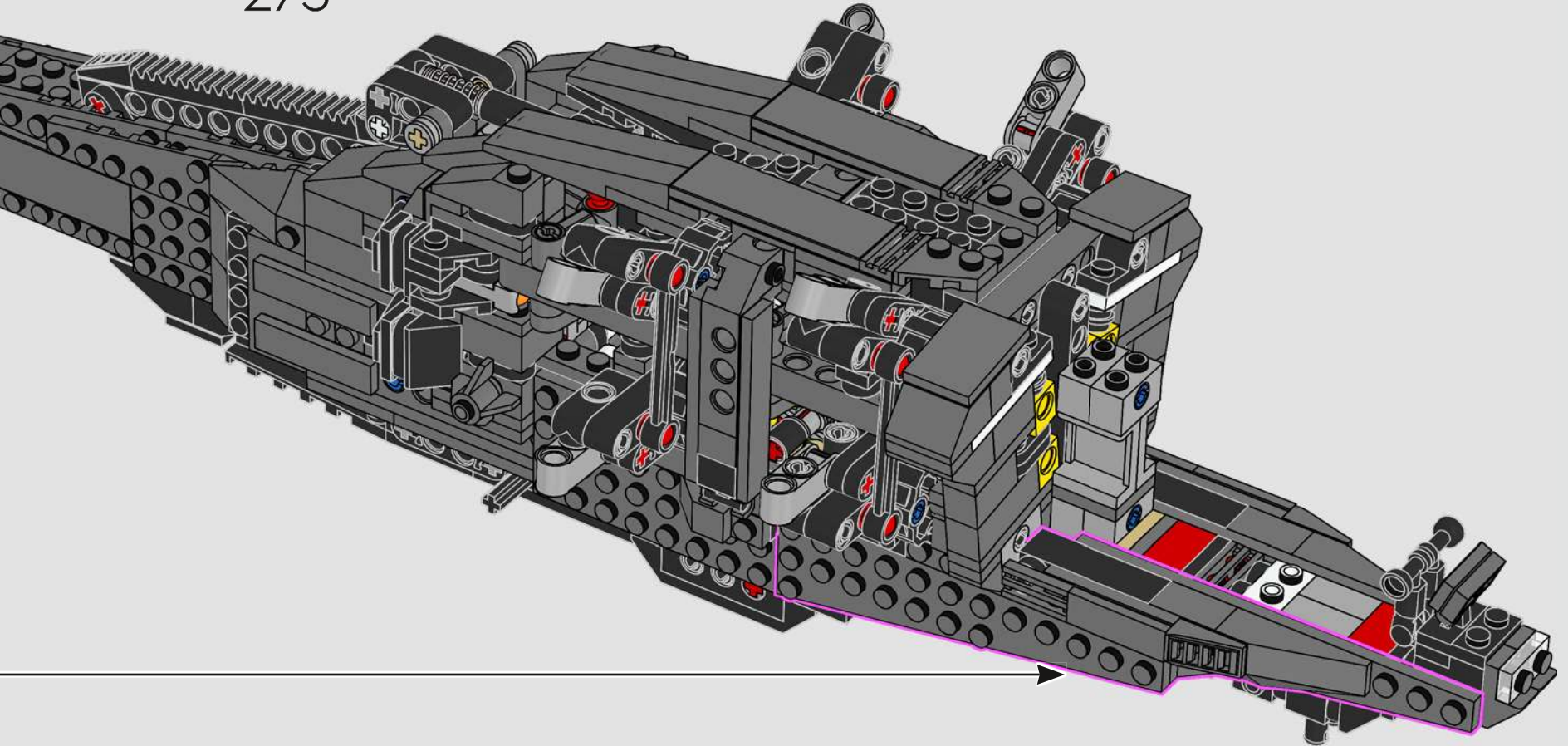

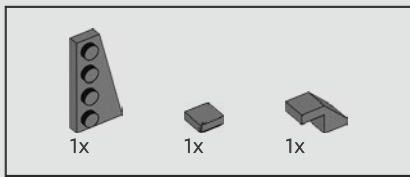

276

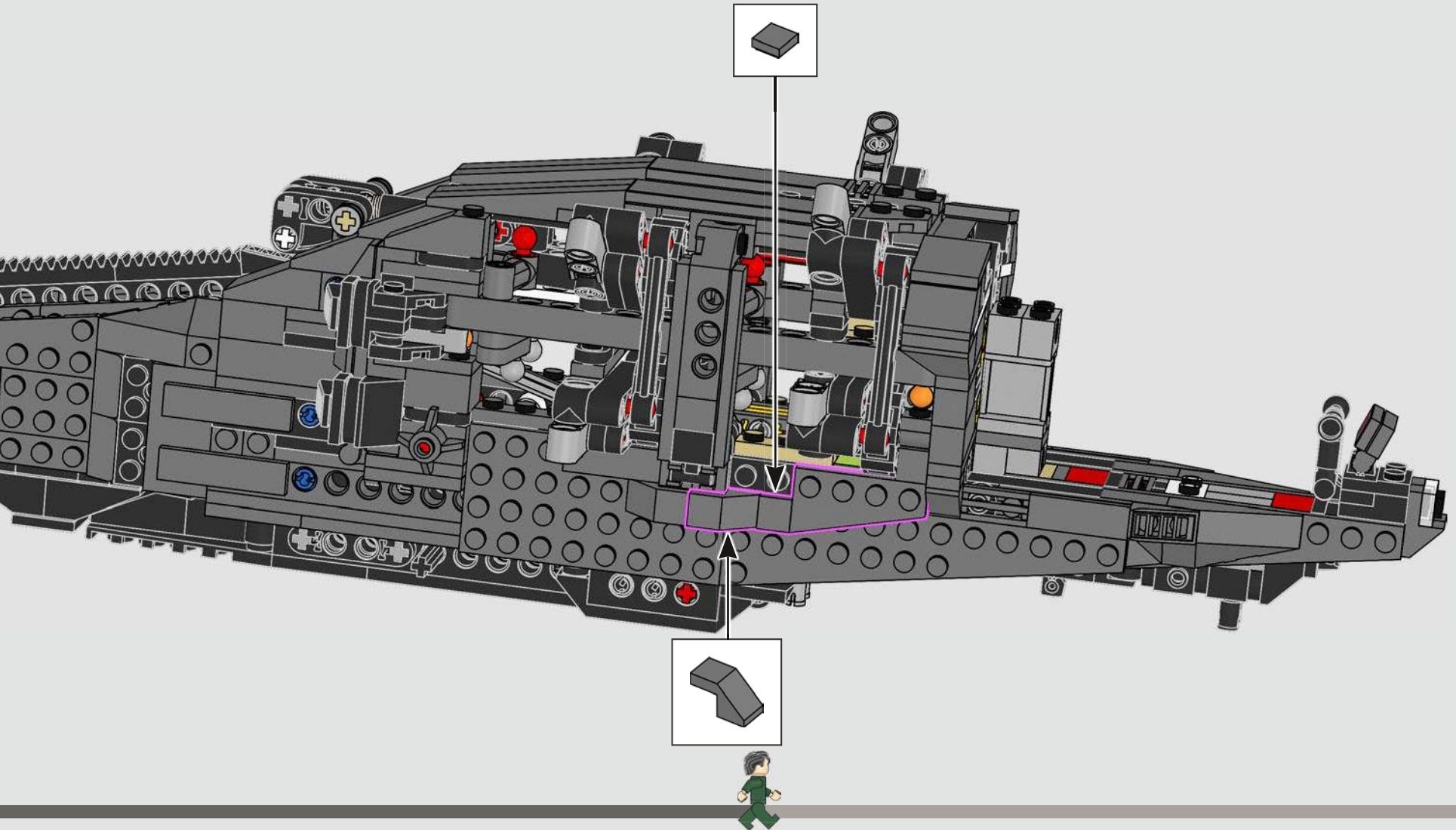

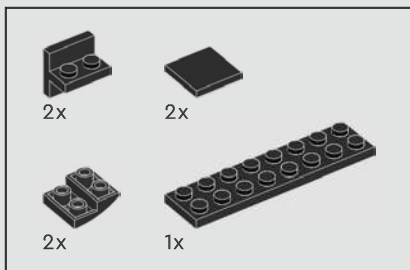

277

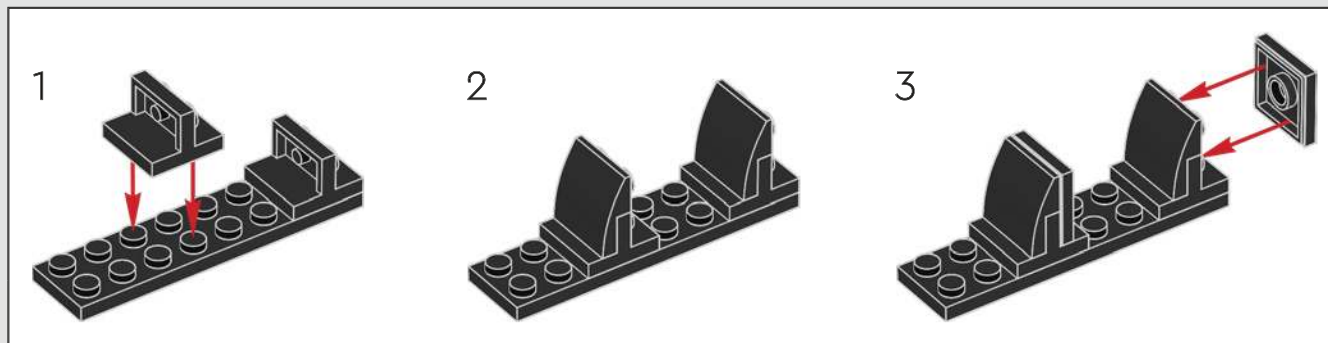

The two cockpit seats are built as a removable section to make it easier to place your minifigure characters in the cockpit.

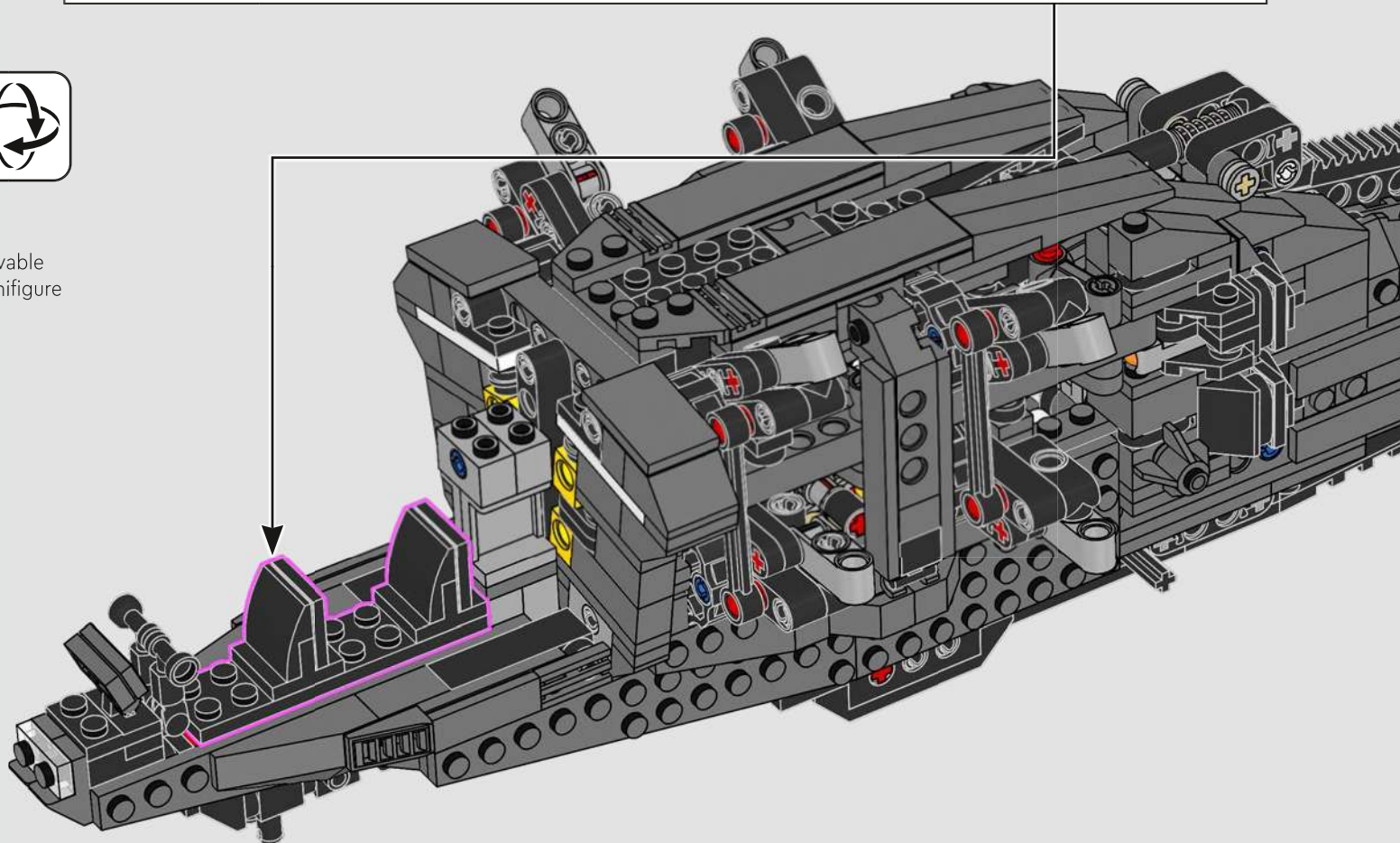

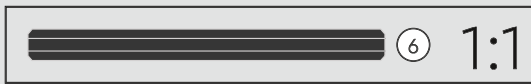
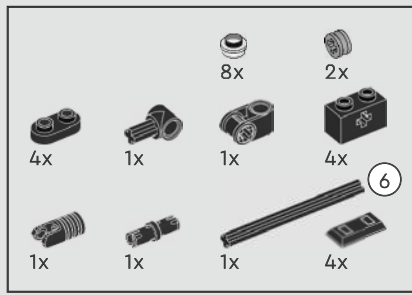

278

1



2



3



4

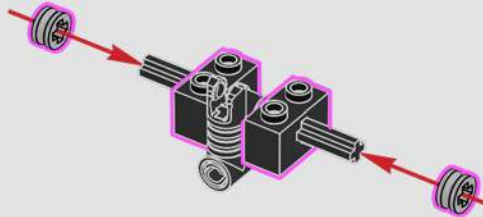

5

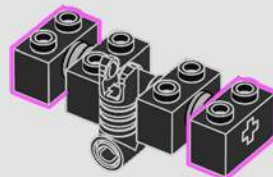

6

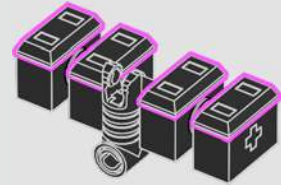

1



2



4x

7



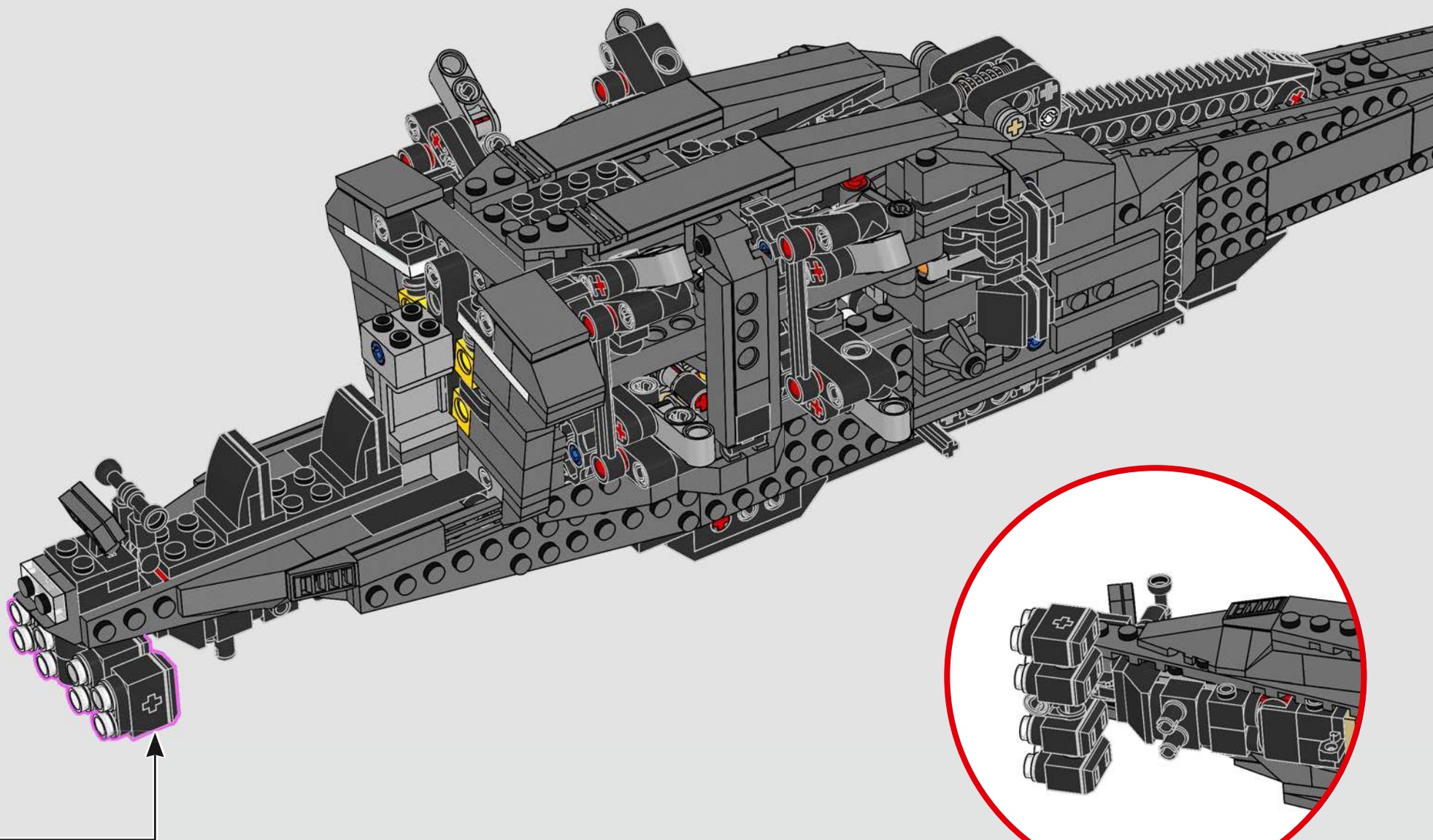

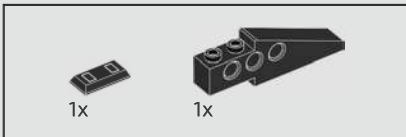
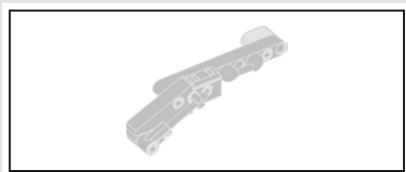

279

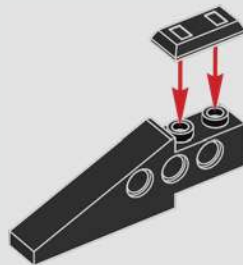

280

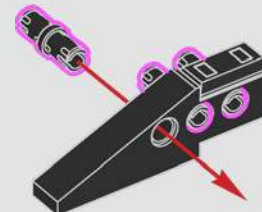

281

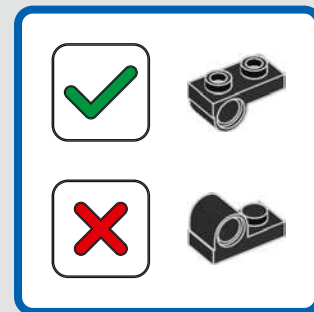
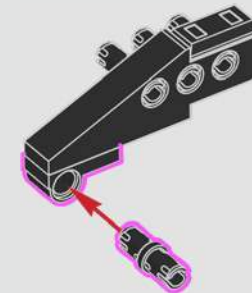



282

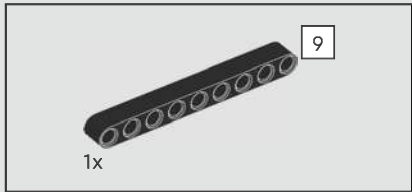
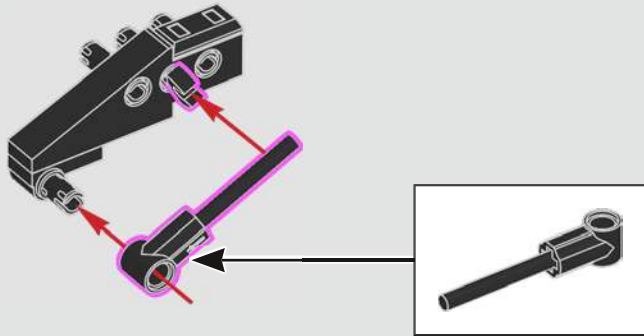

283

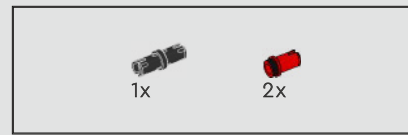
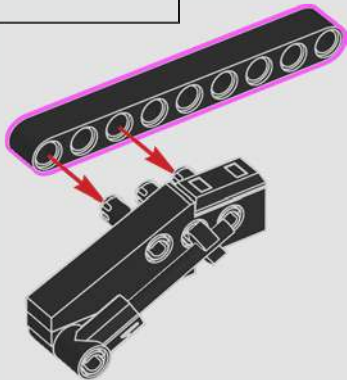

284

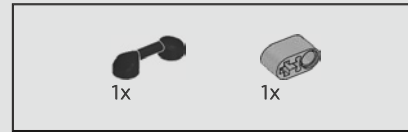
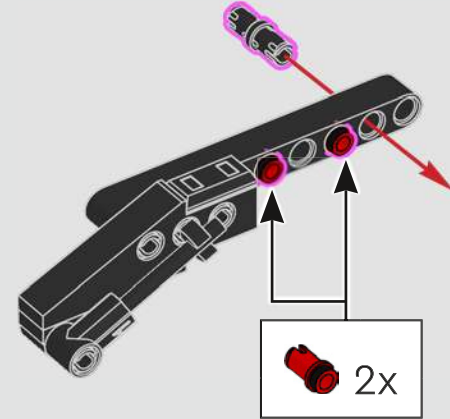

285

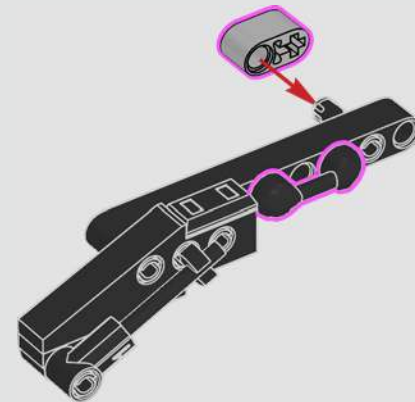

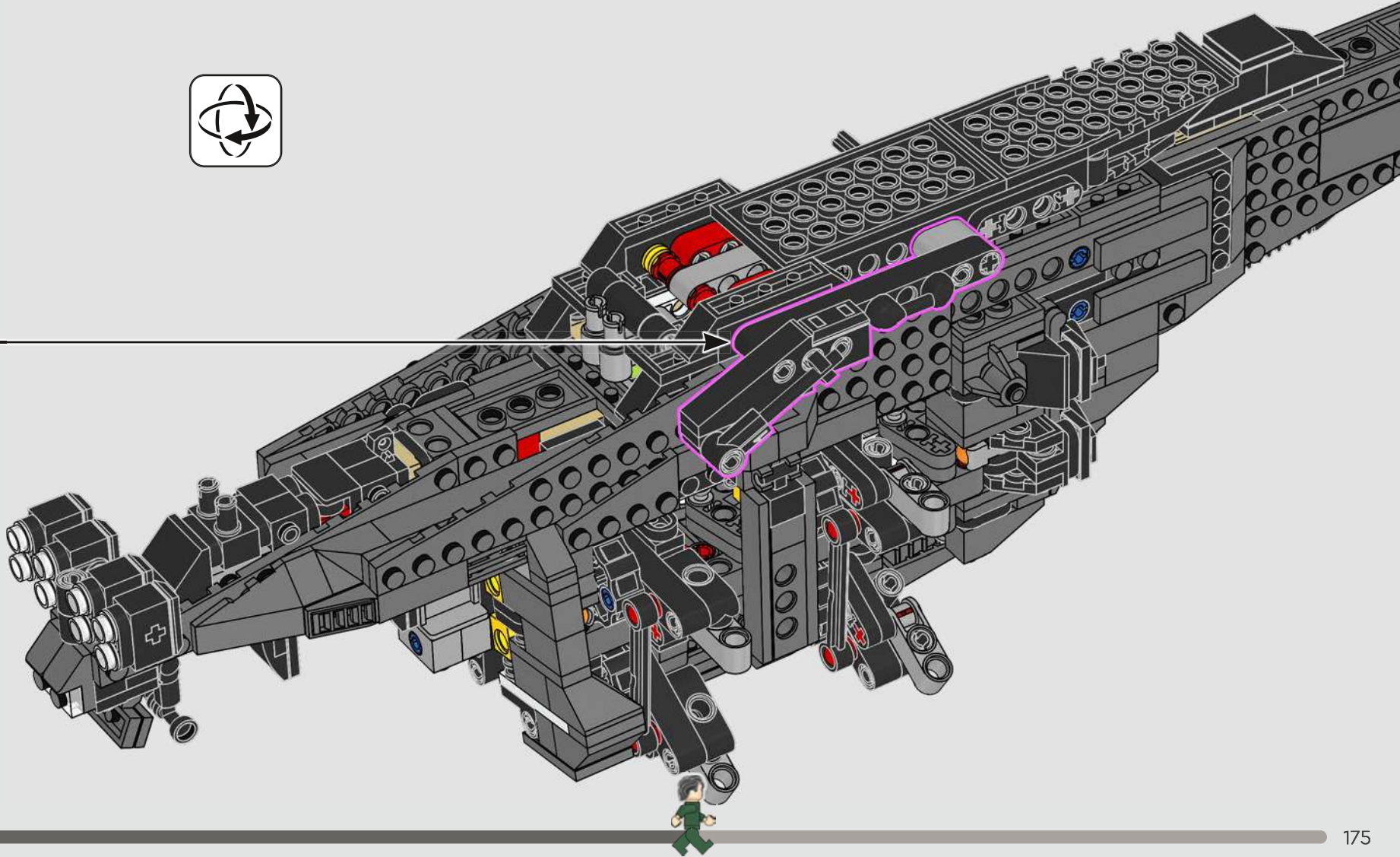

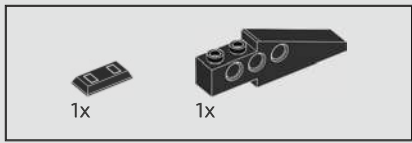

287

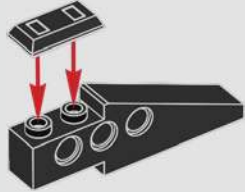

288

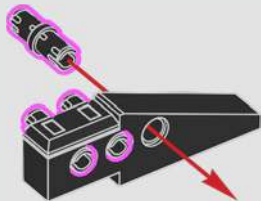

289

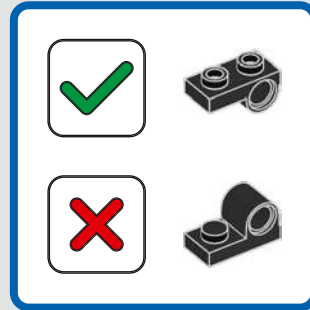

290

This wing brick provides the perfect angle to allow the landing feet to sit flat on the ground when extended.

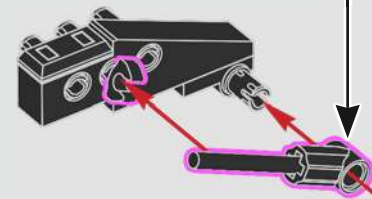
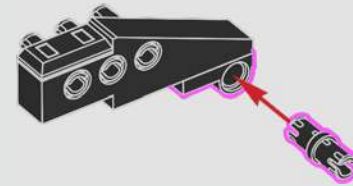

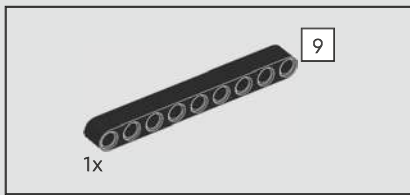

291

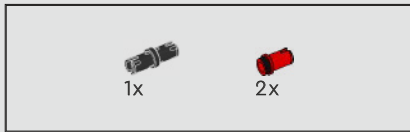
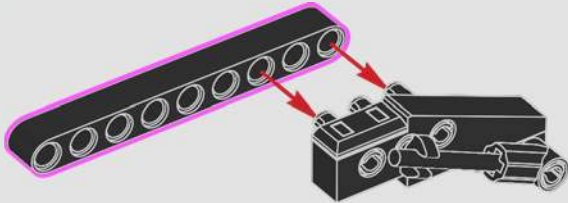

292

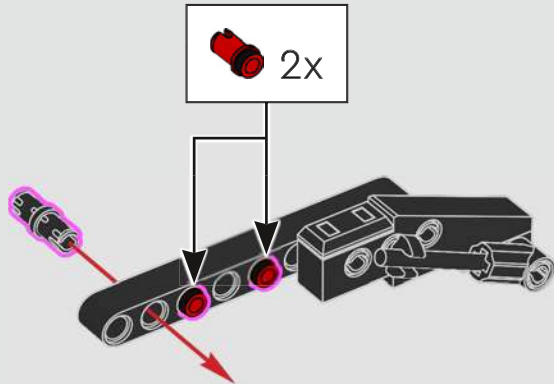

293

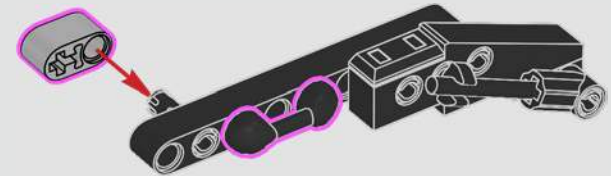

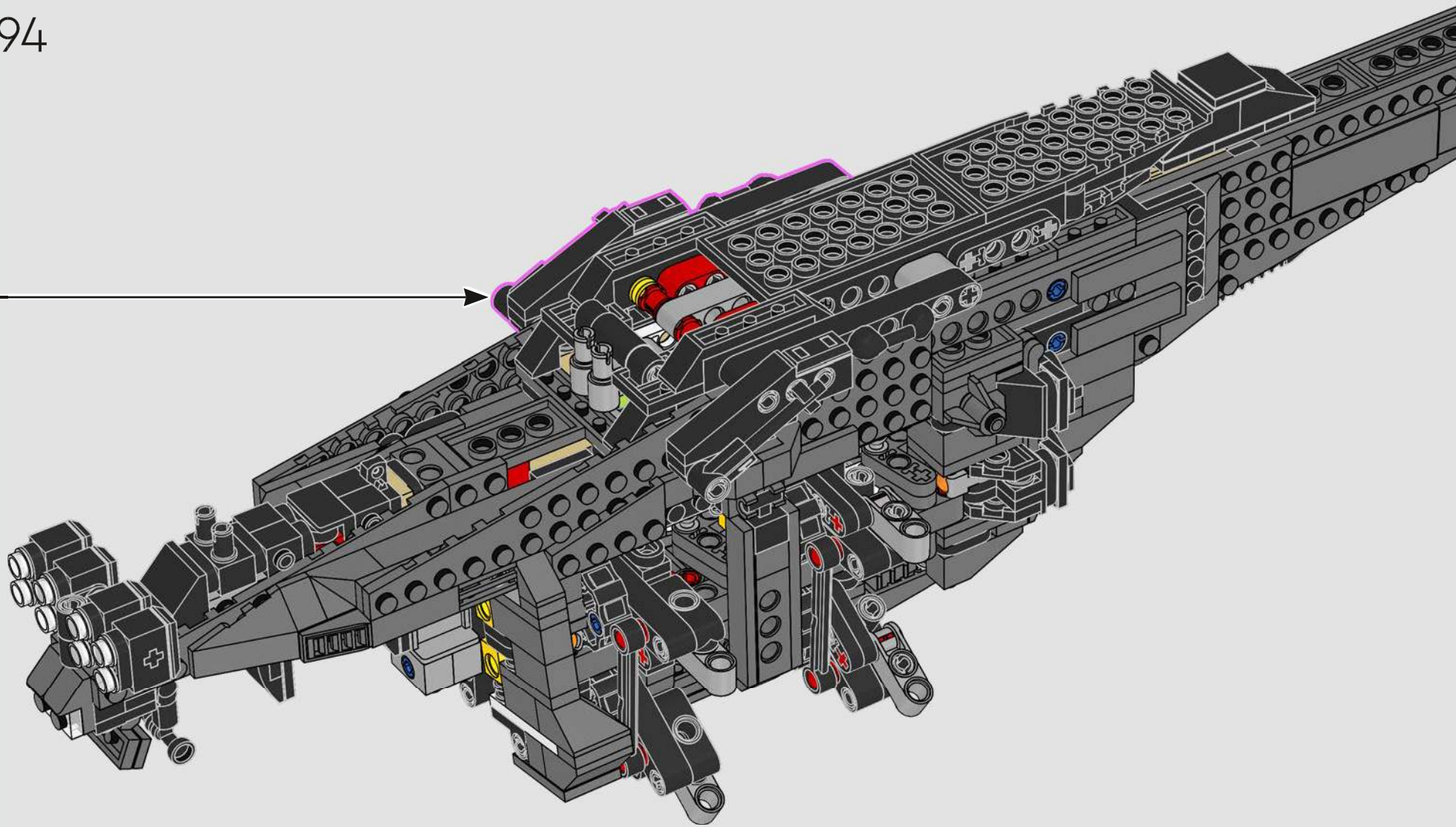

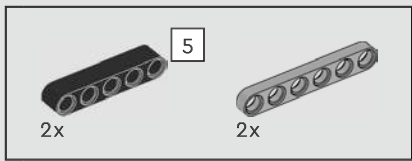

296

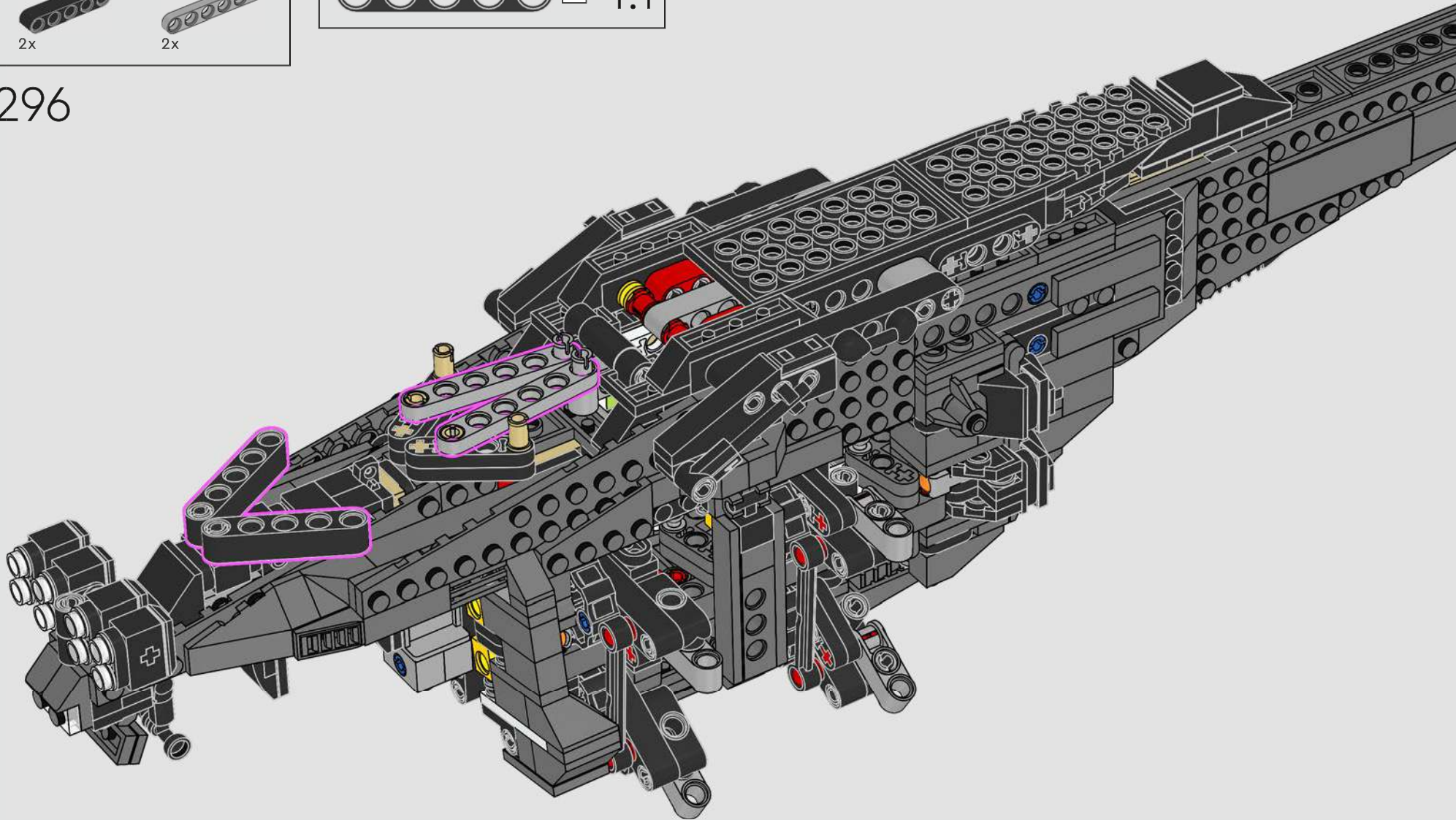



300

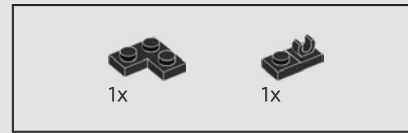
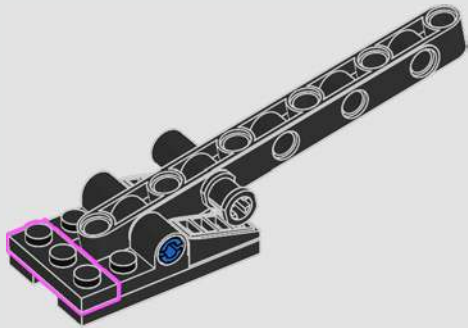

301

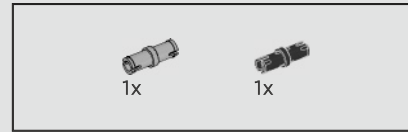
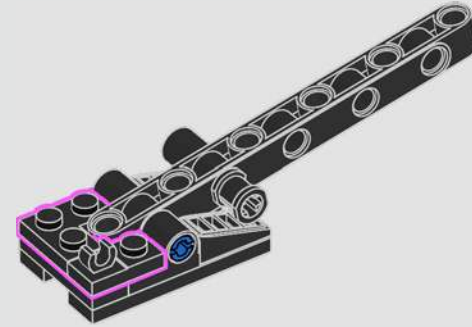

302

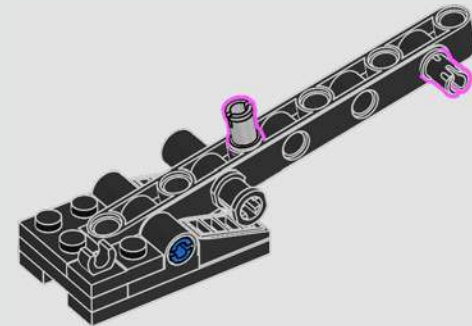

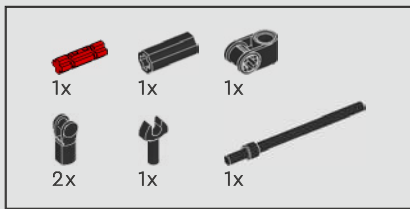

303

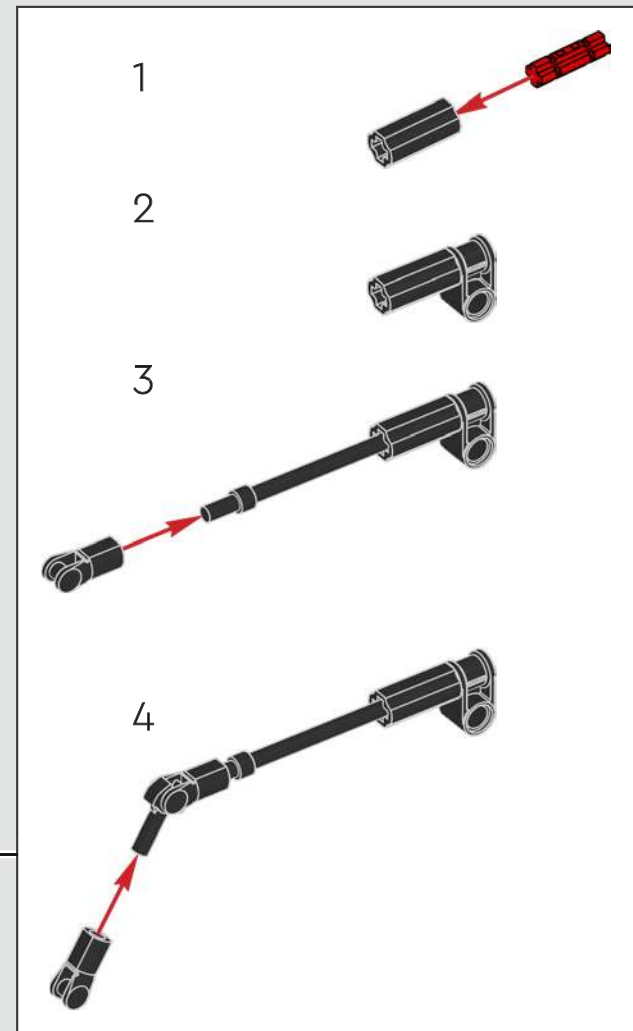
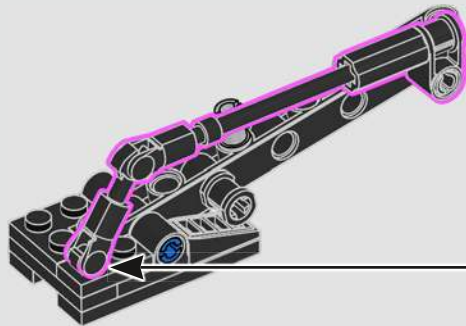

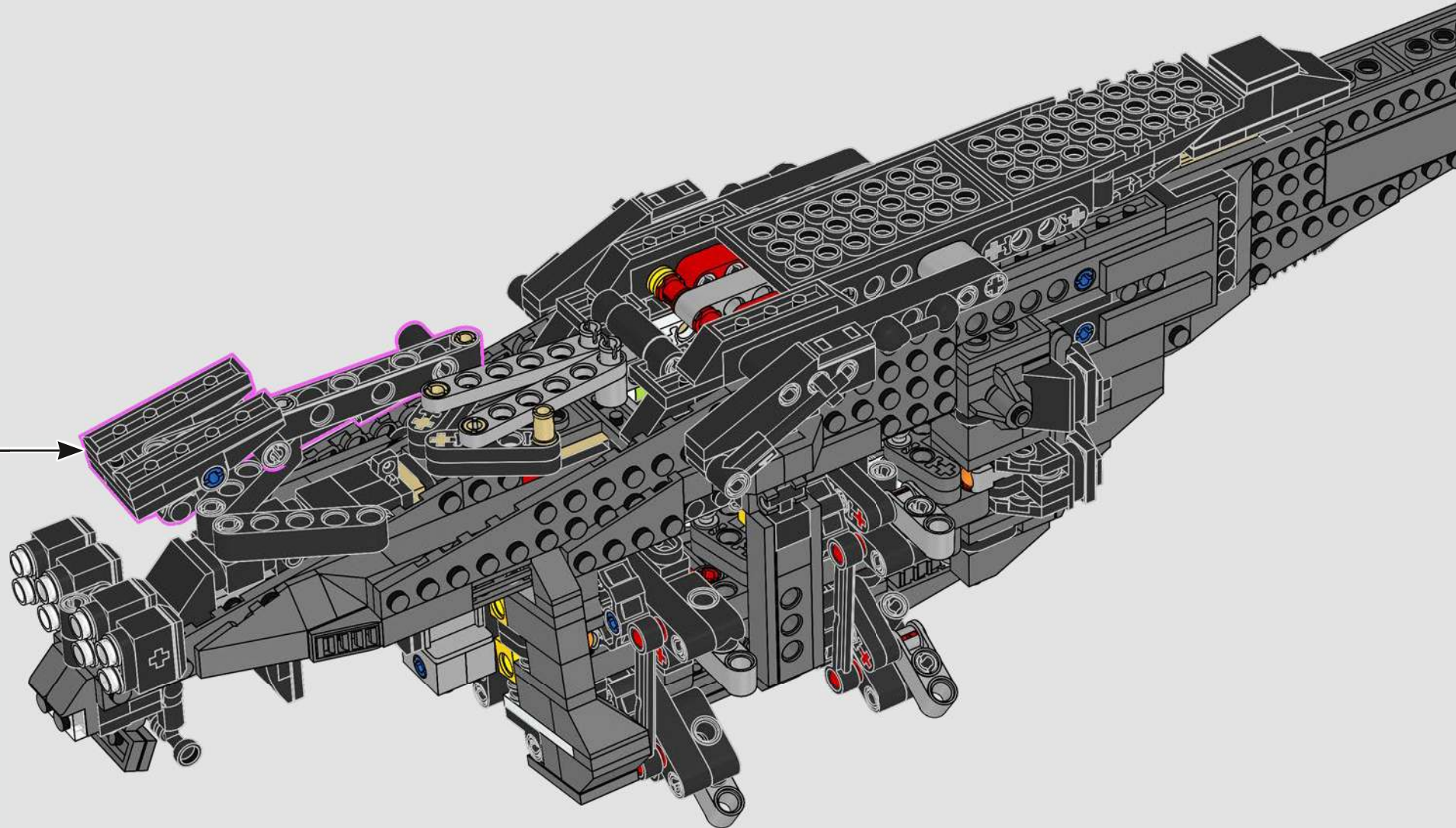

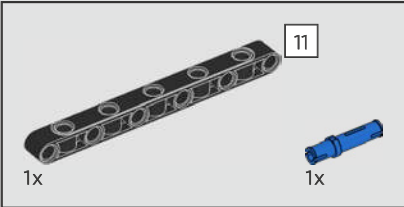
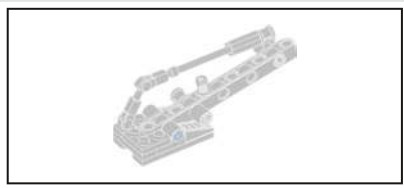

305

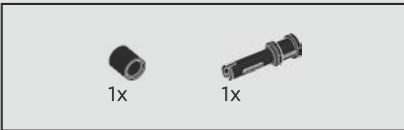
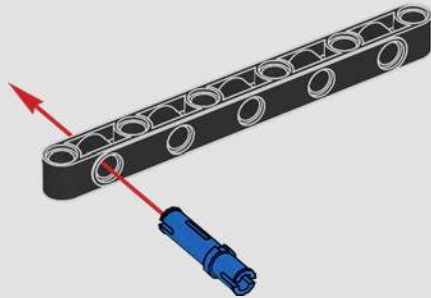

306

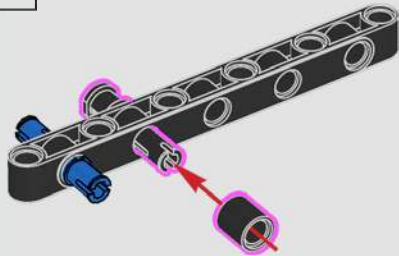

307

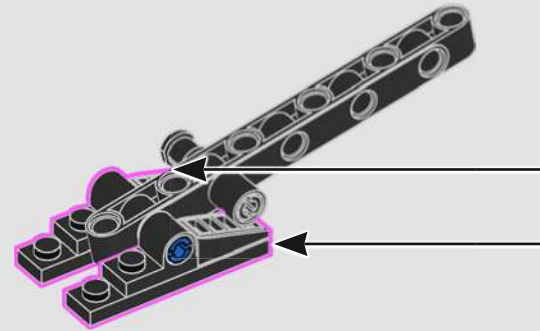
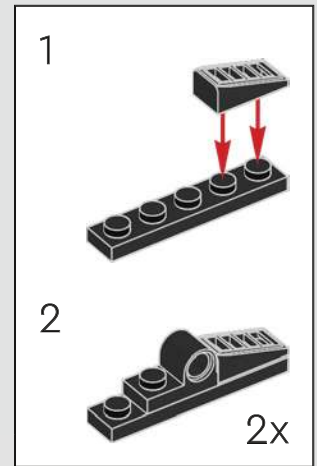



308

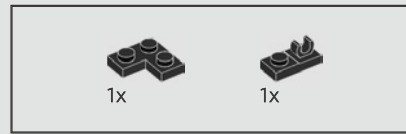
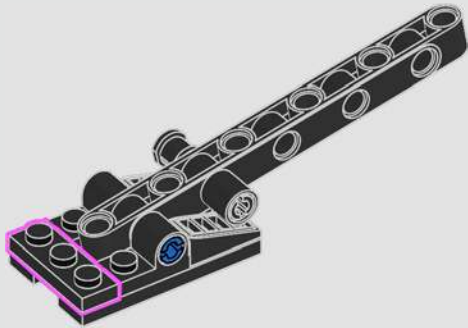

309

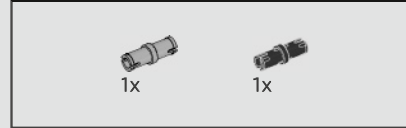
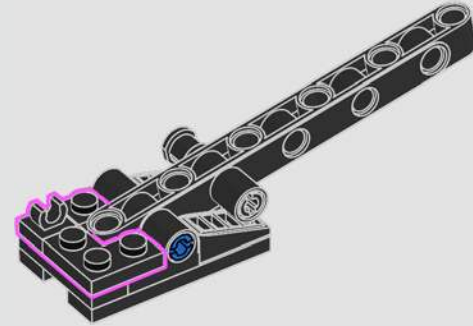

310

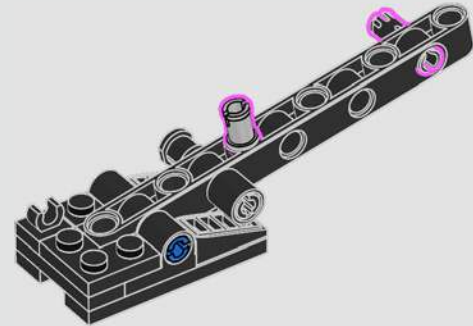

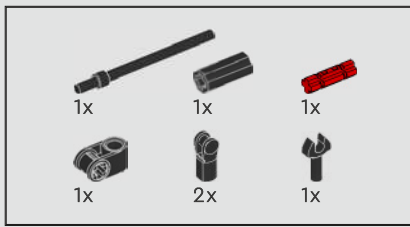

311

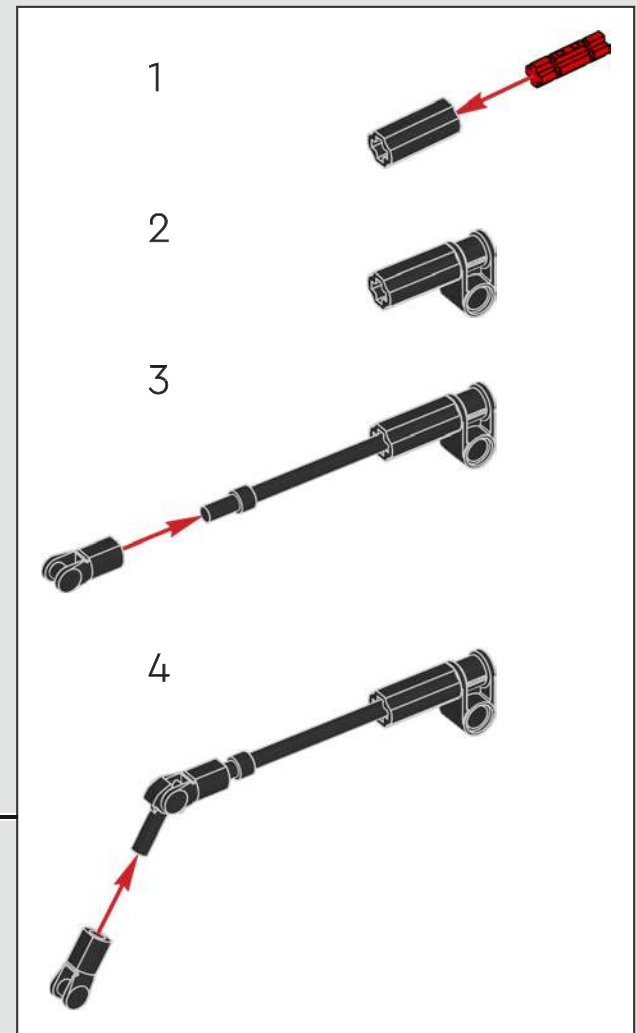
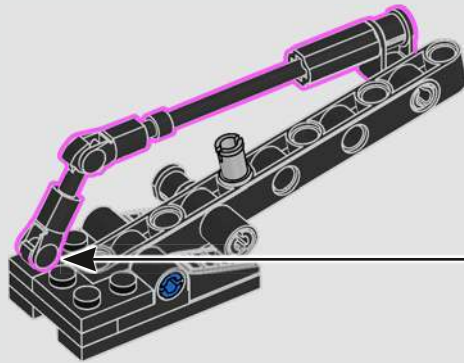

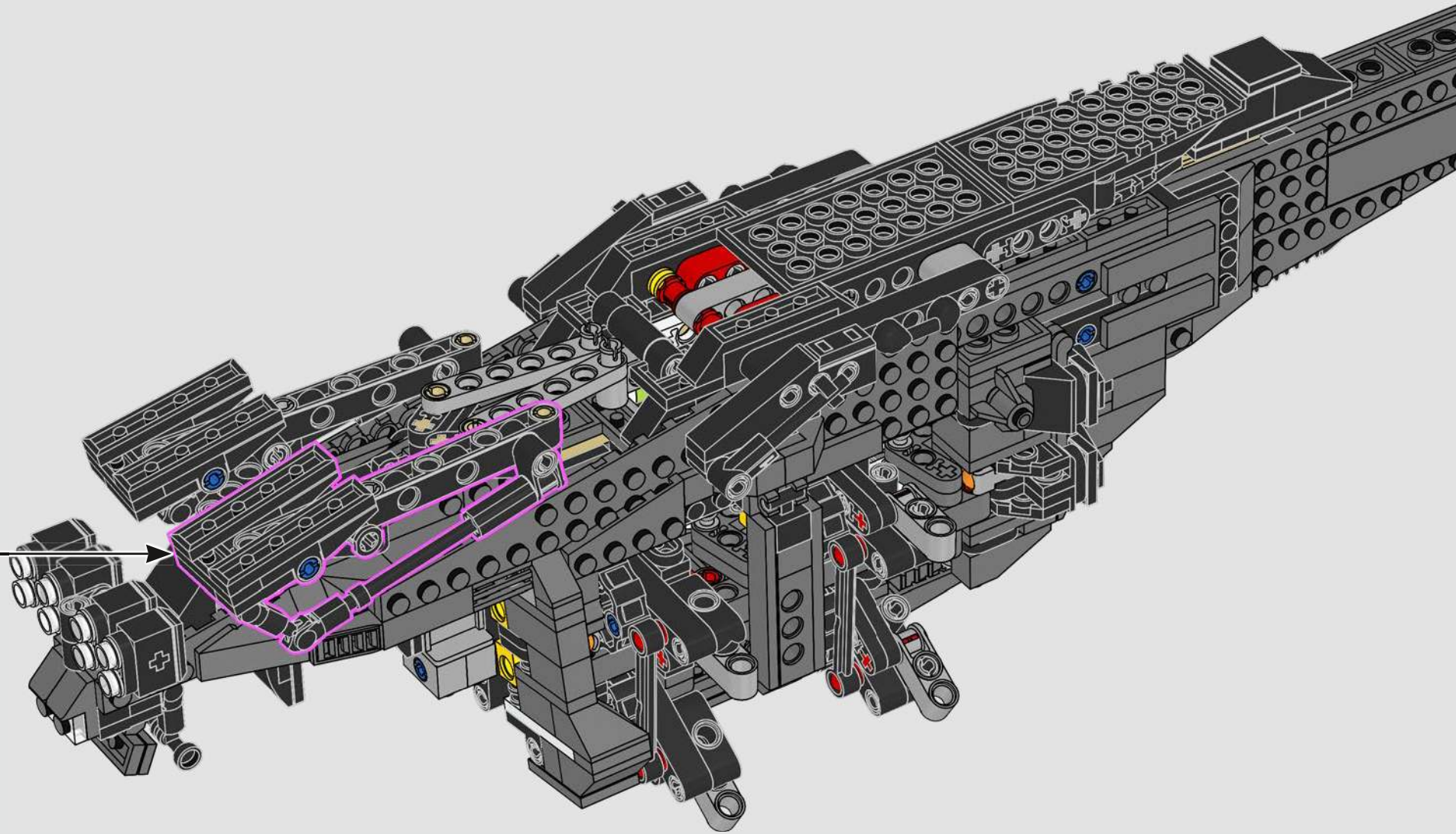

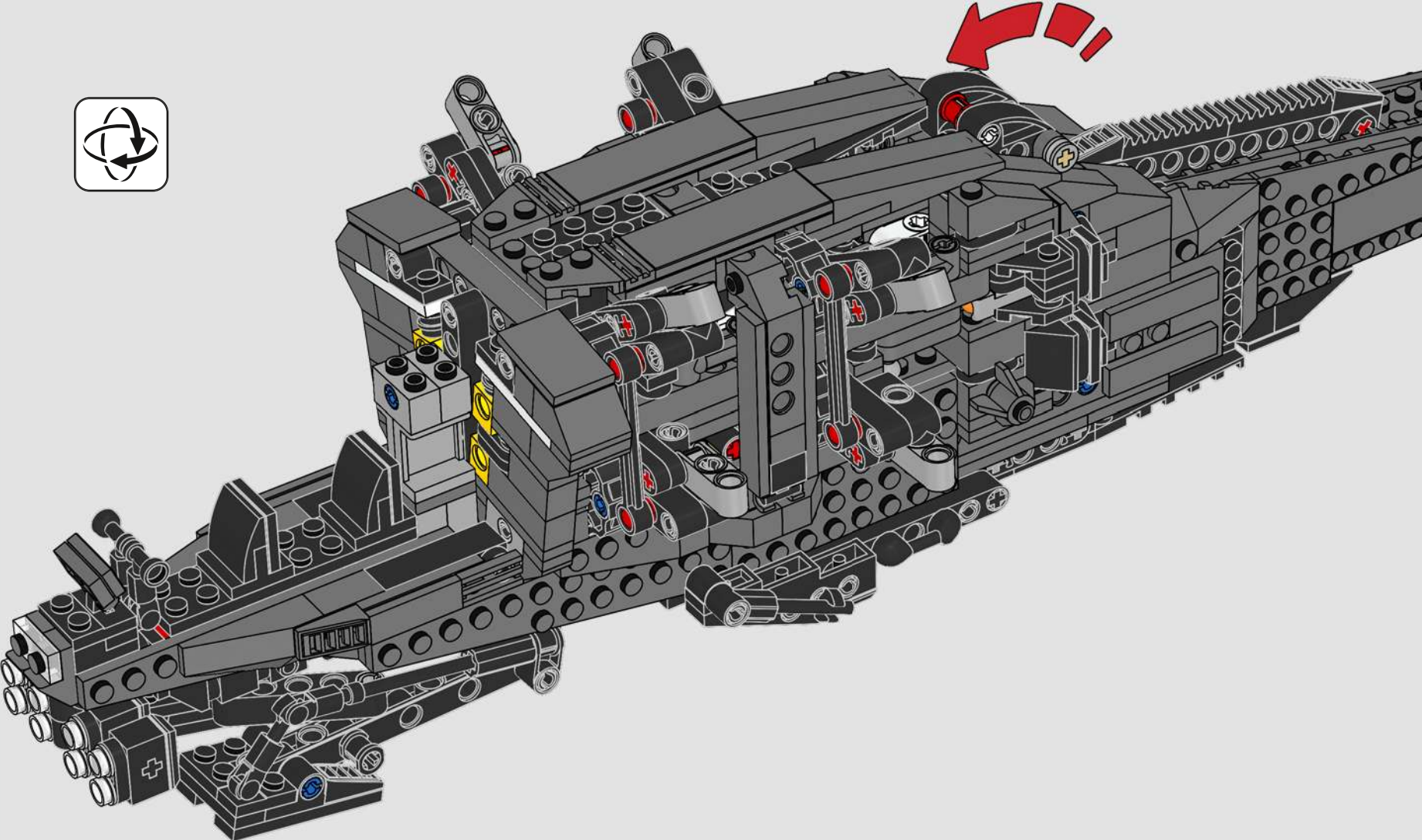

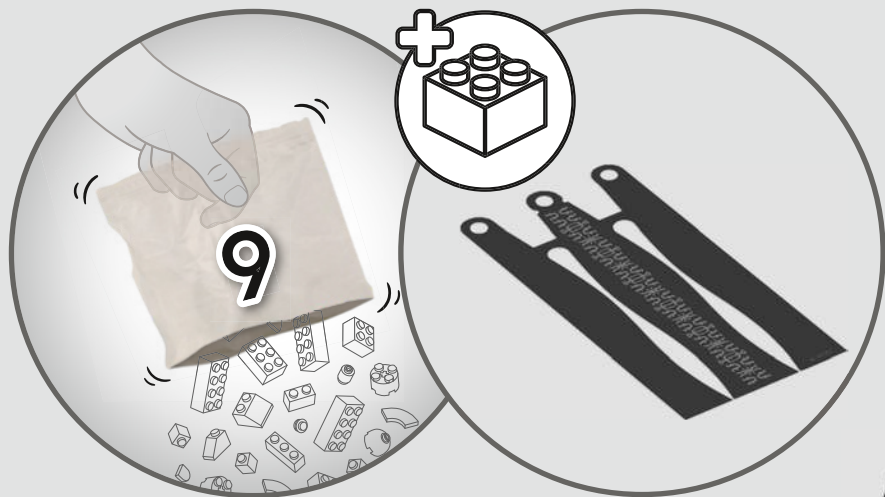

1

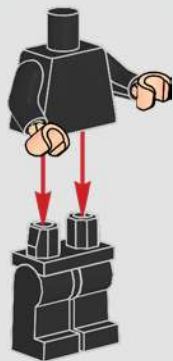

2

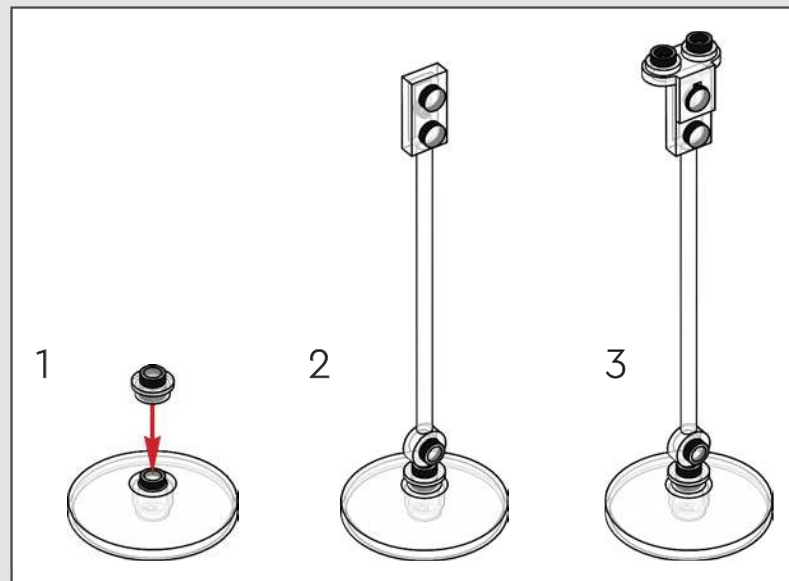
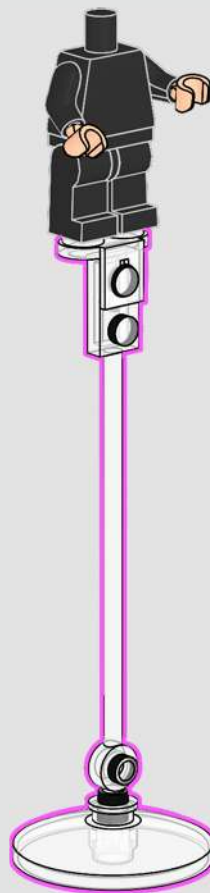

3

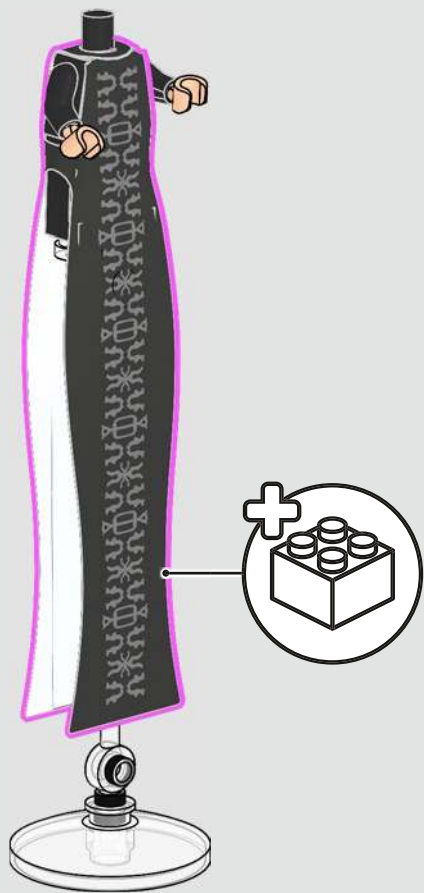

4



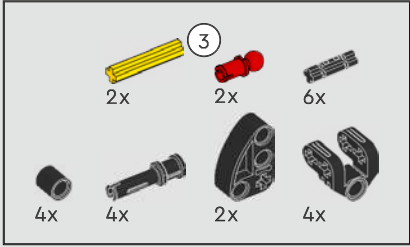
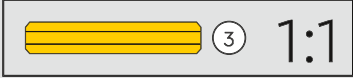
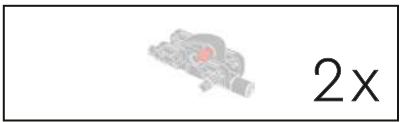

314

1



2

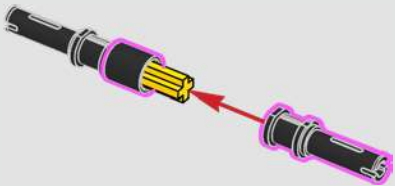

3

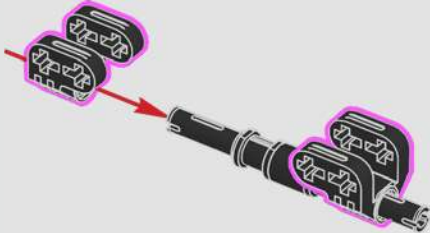

4

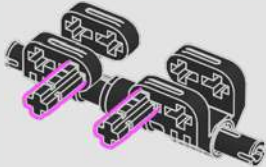

5

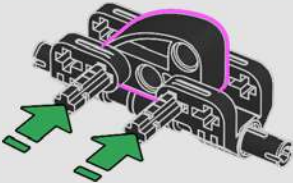

6

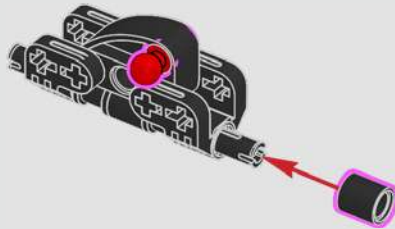

7

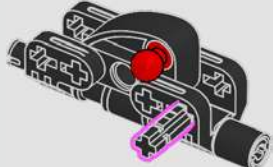

8

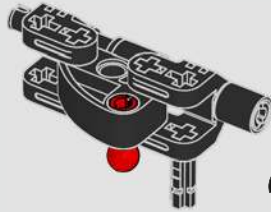

2x

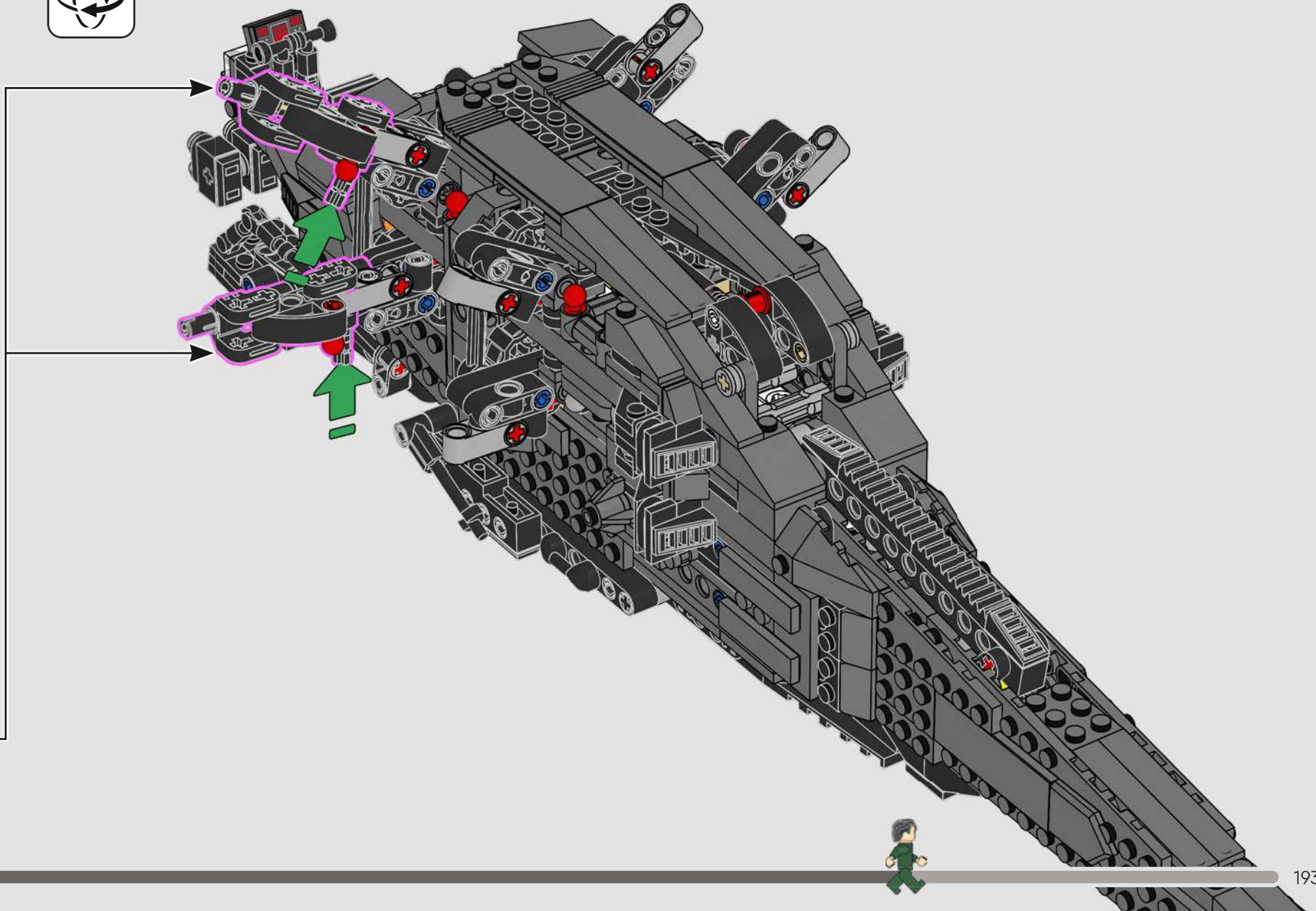

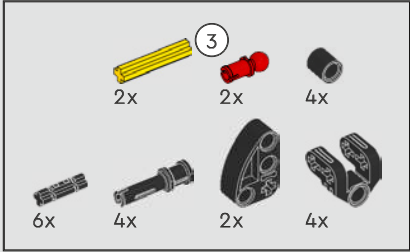
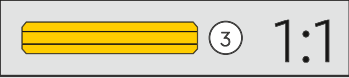
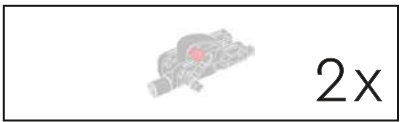

315

1



2

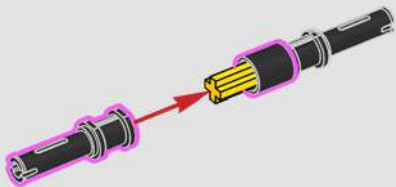

3

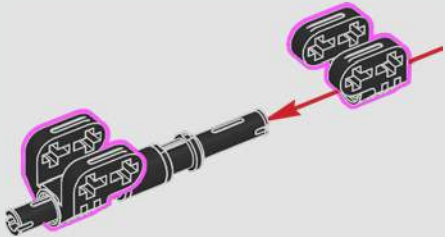

4

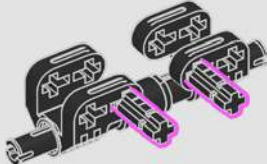

5

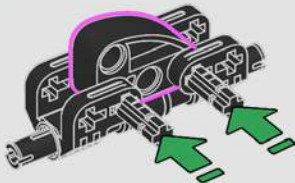

6

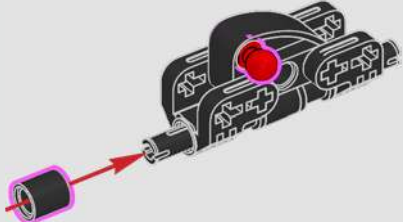

7

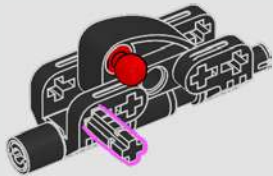

2x



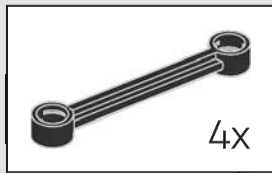
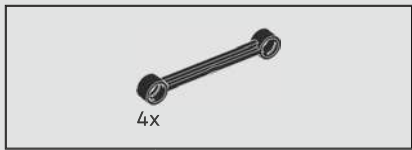

316

The track rod connections to the core of the model ensure that as the wings flap up and down, they are not pulled backwards or forwards by the wing-opening mechanism.

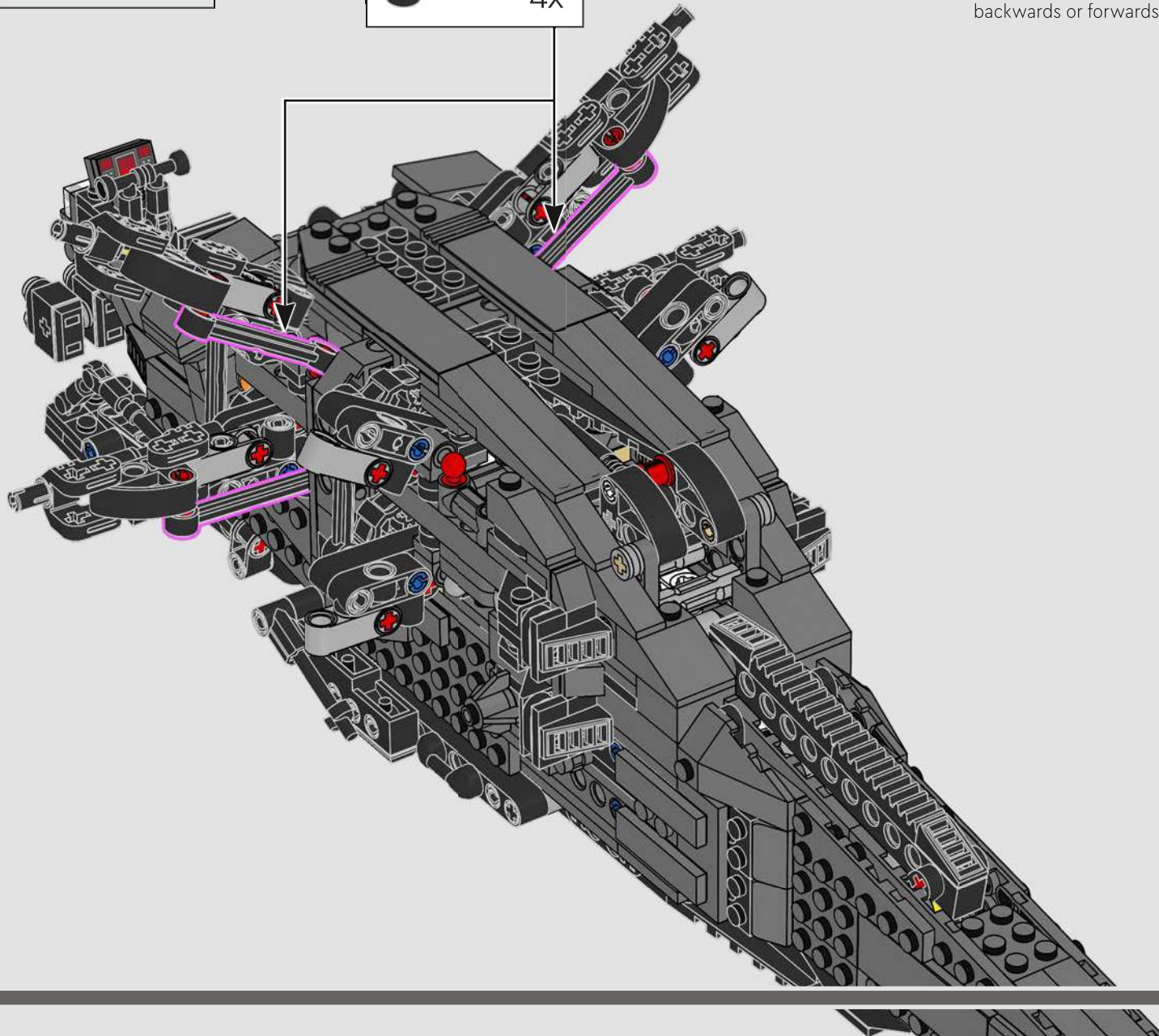

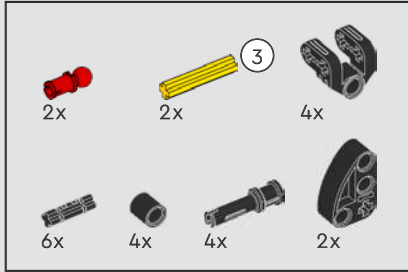
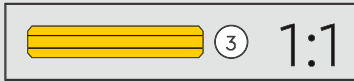
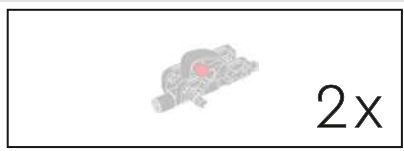

317

1



2

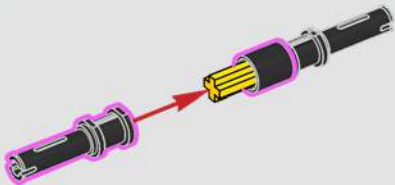

3

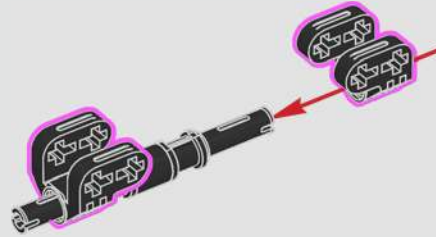

4

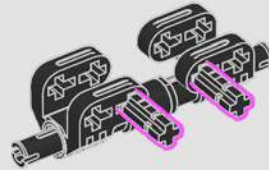

5

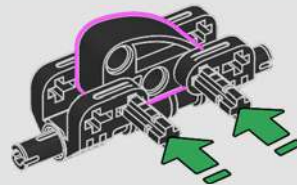

6

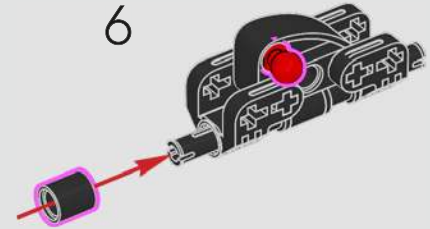

7

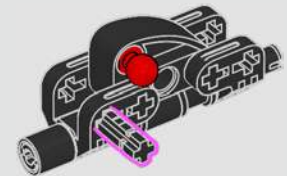

2x



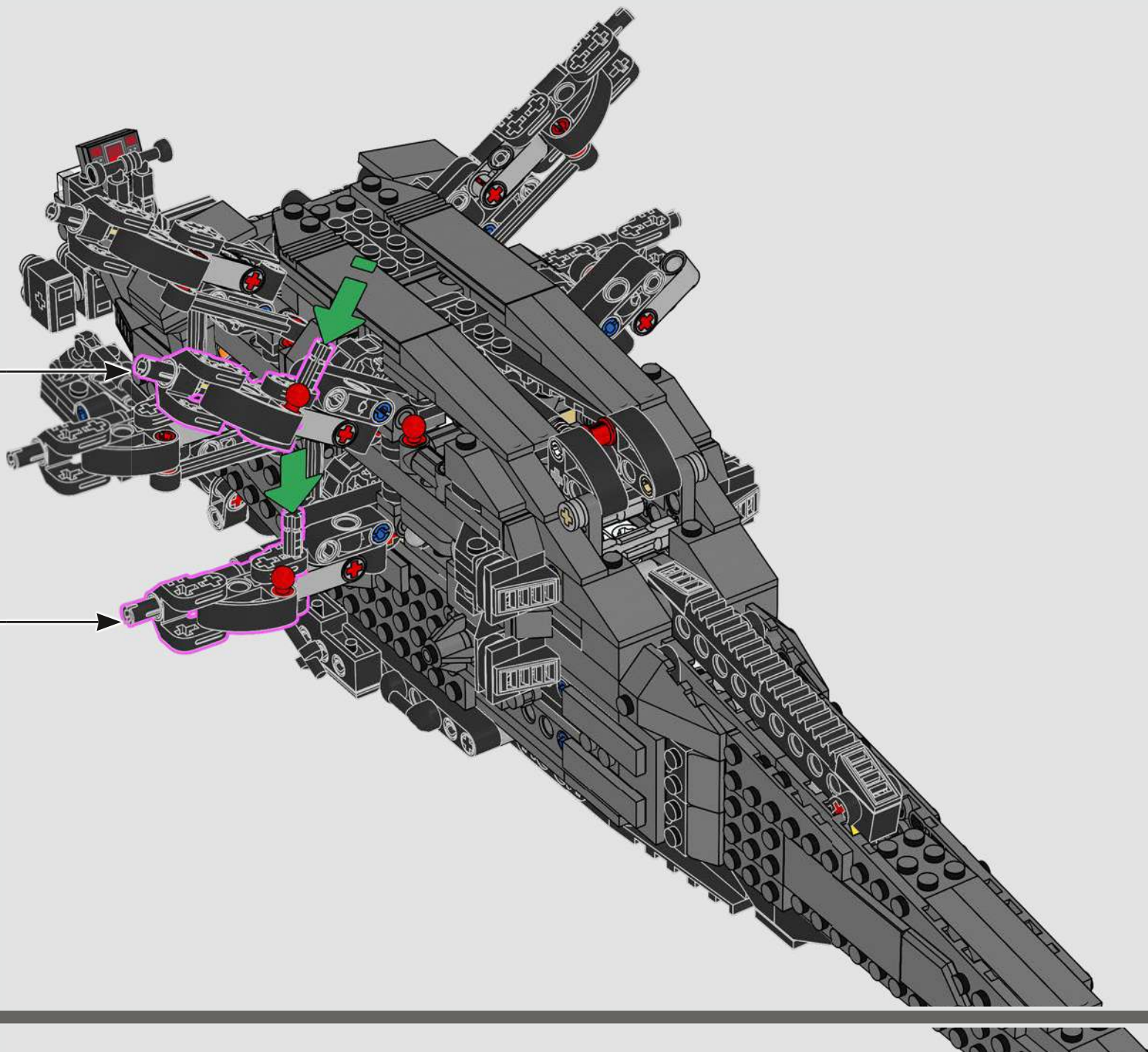

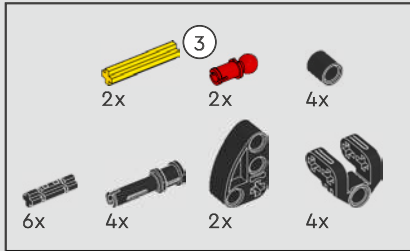
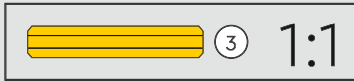
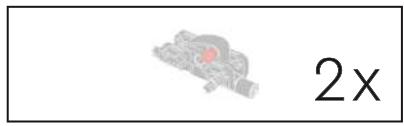

318

1



2

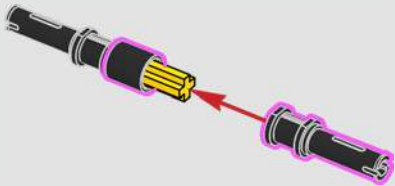

3

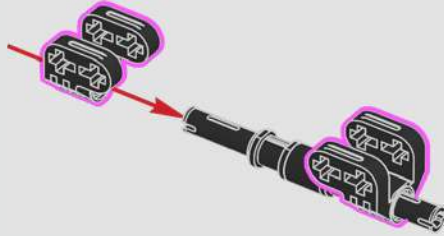

4

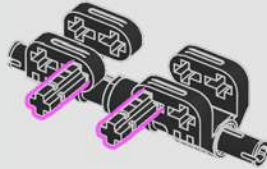

5

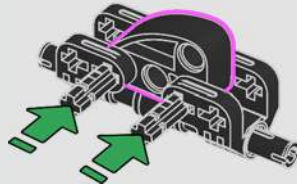

6

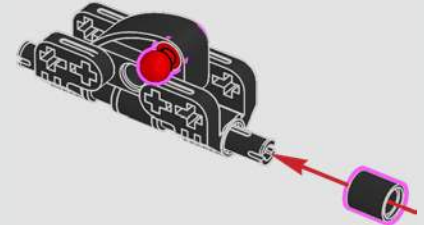

7

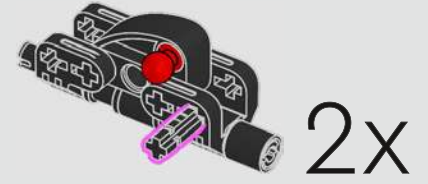

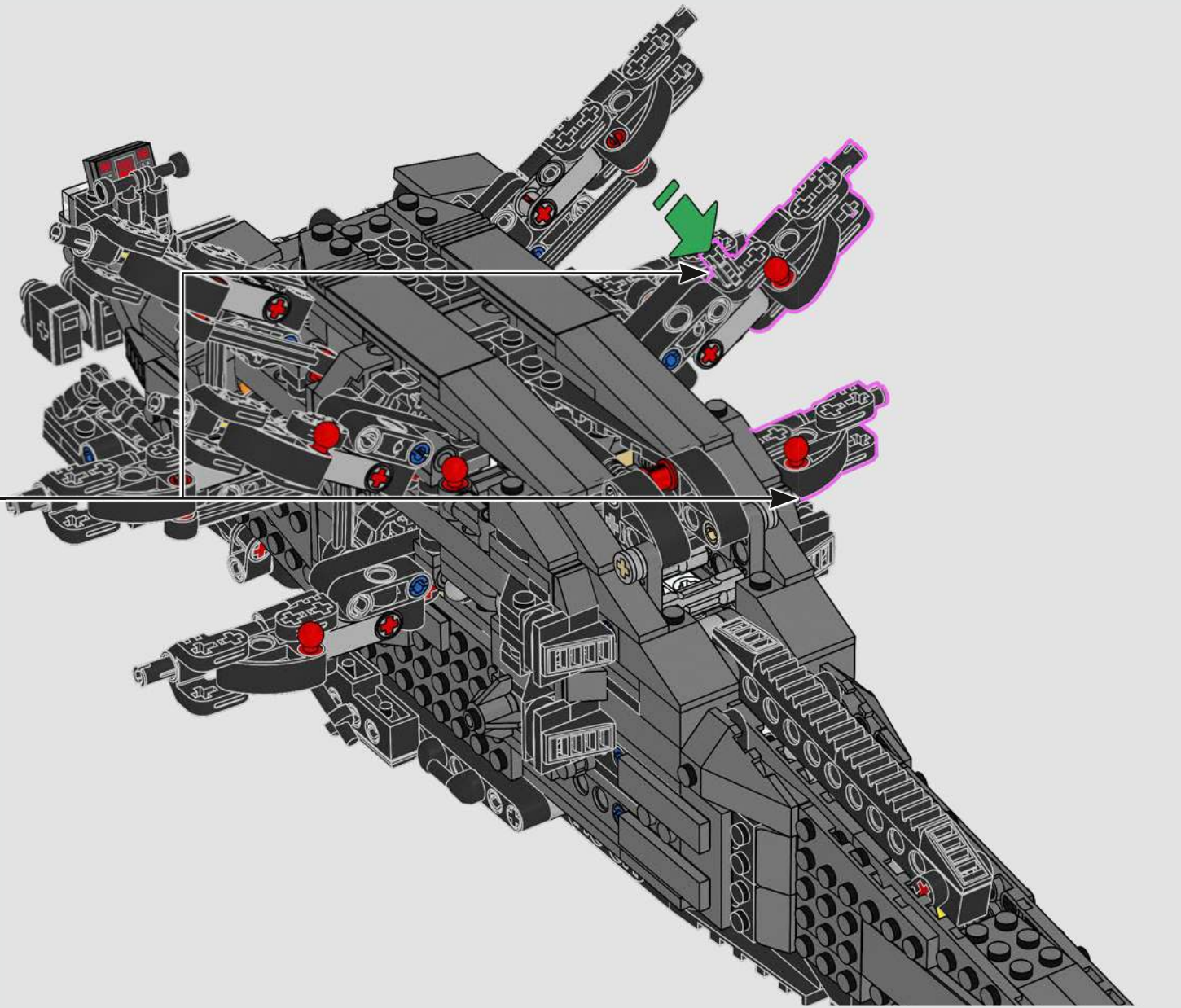

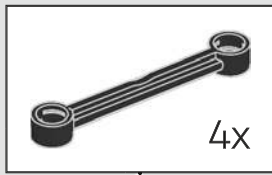
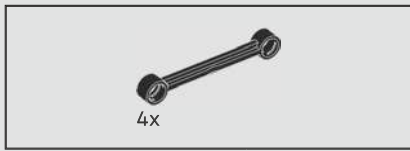

319

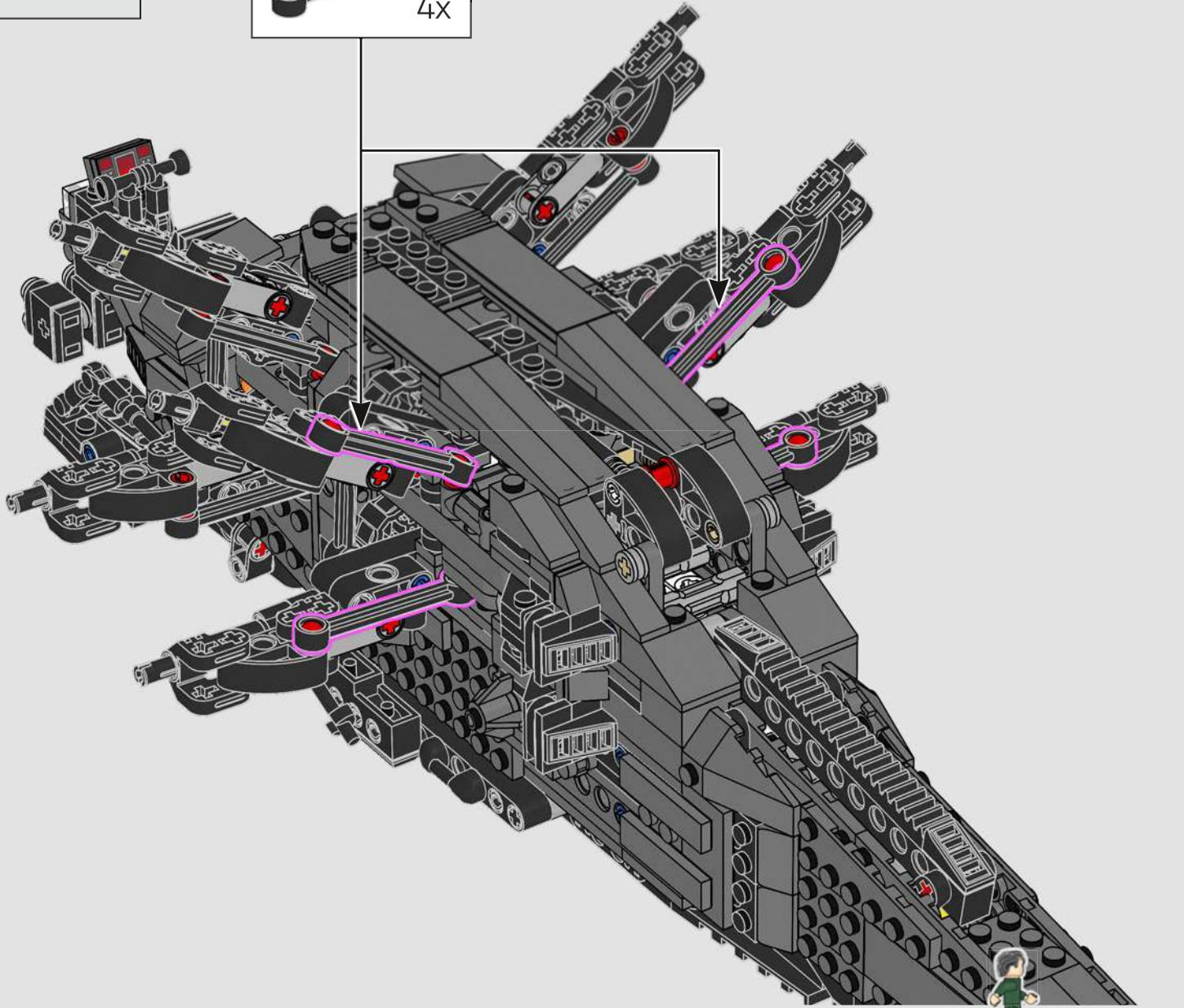

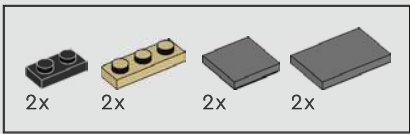

320

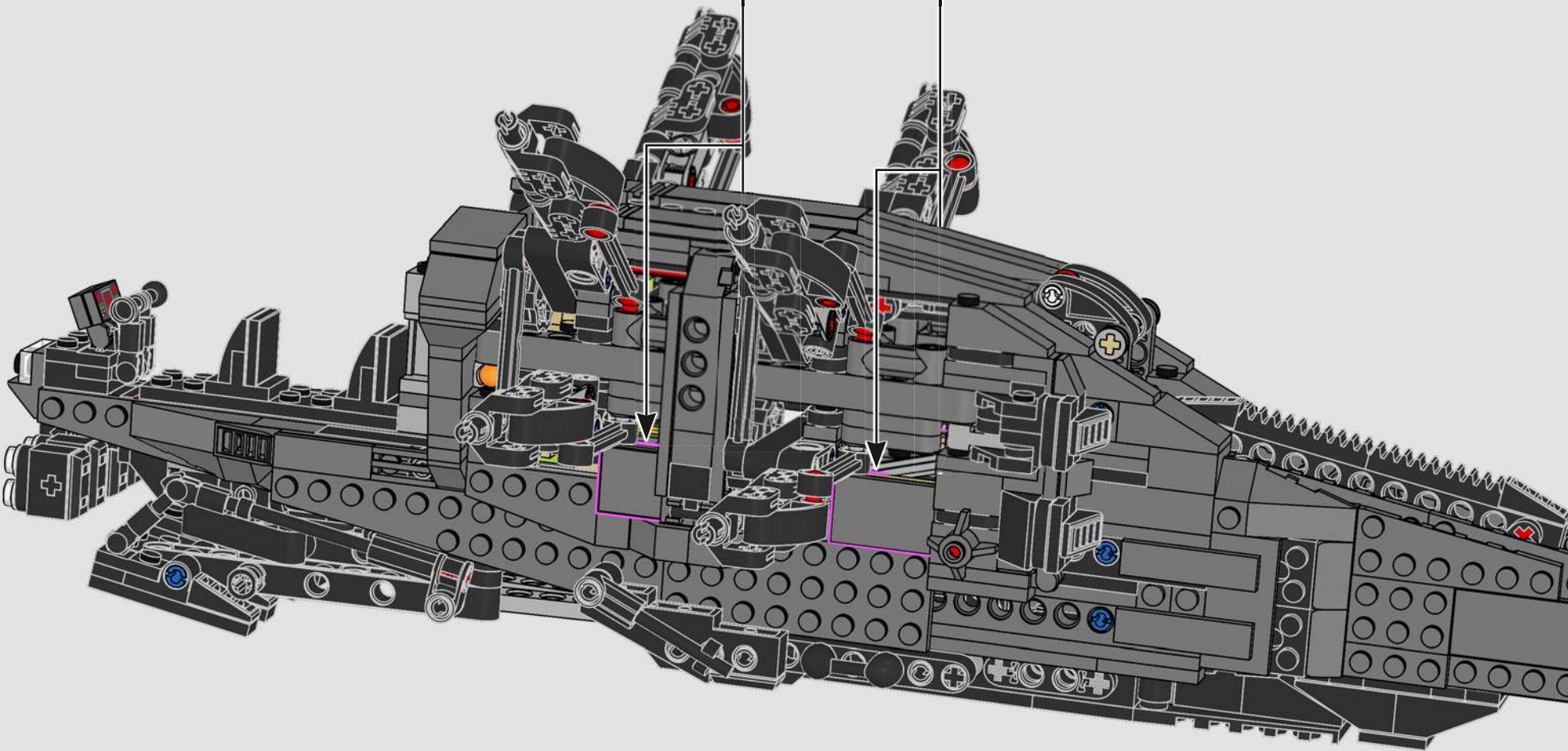
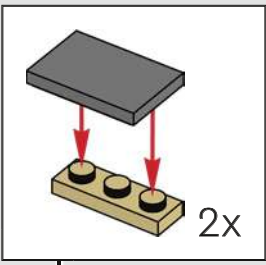
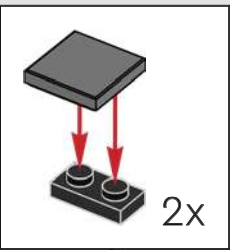

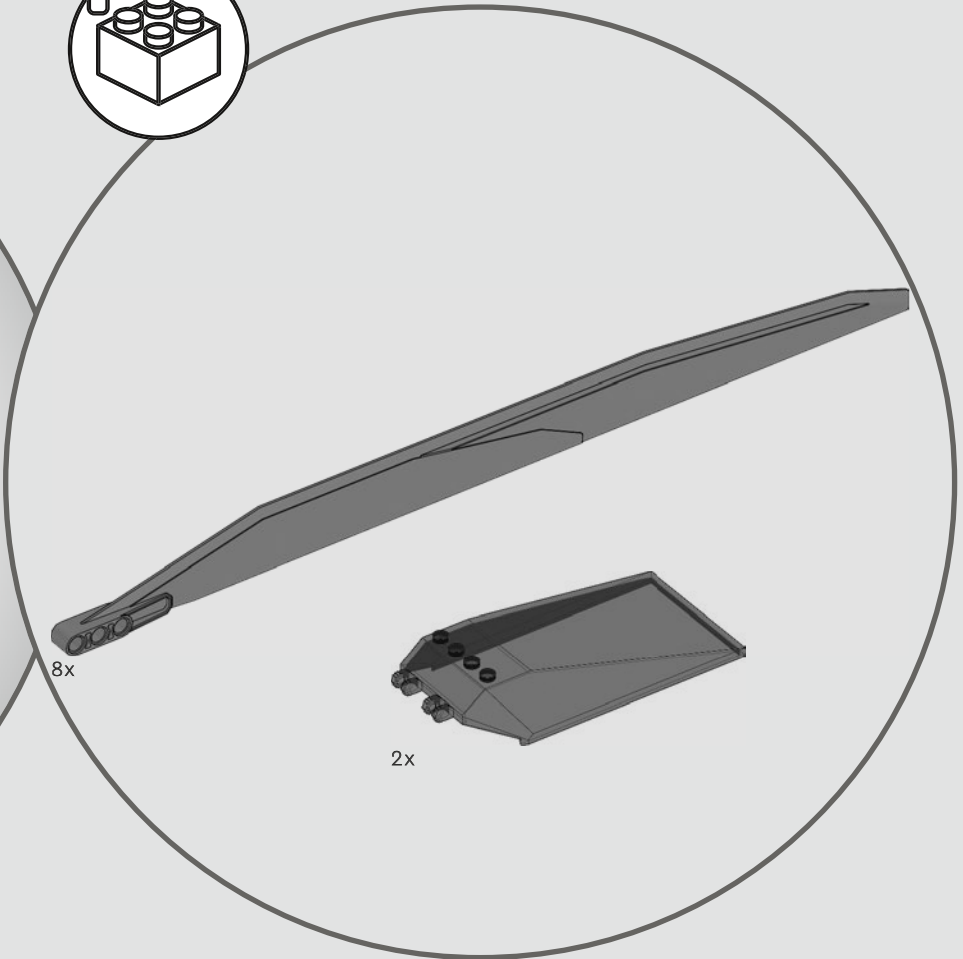
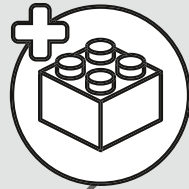

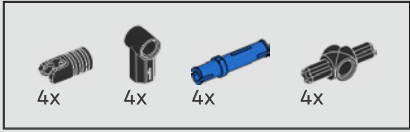
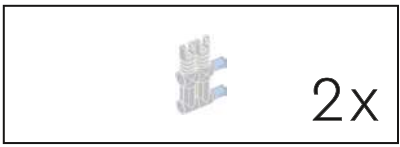

321

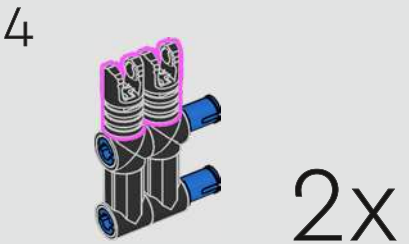
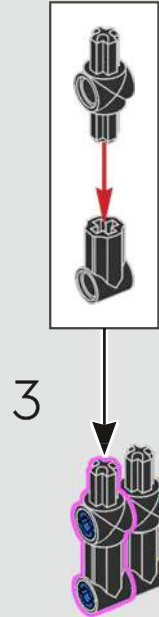

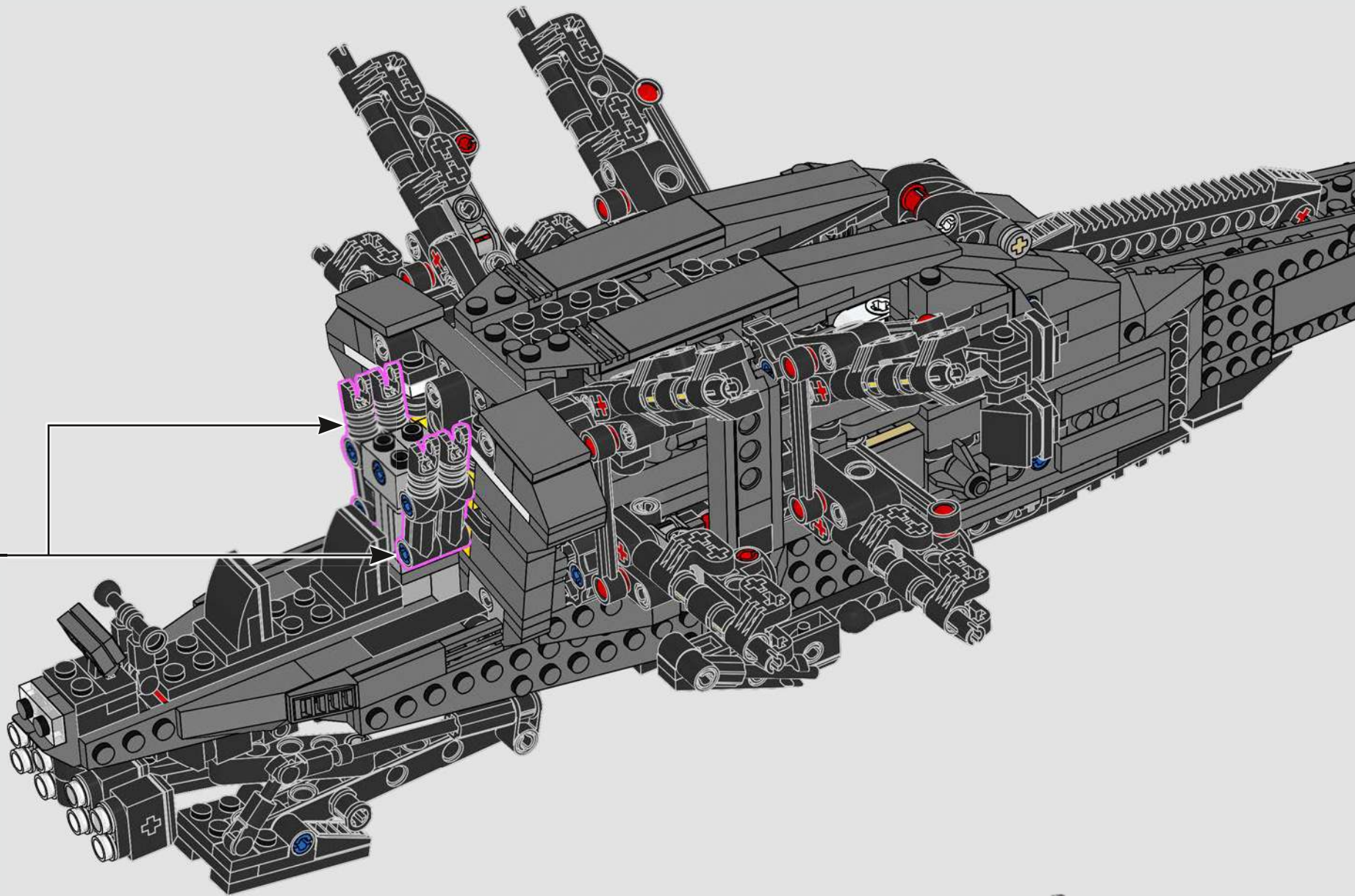

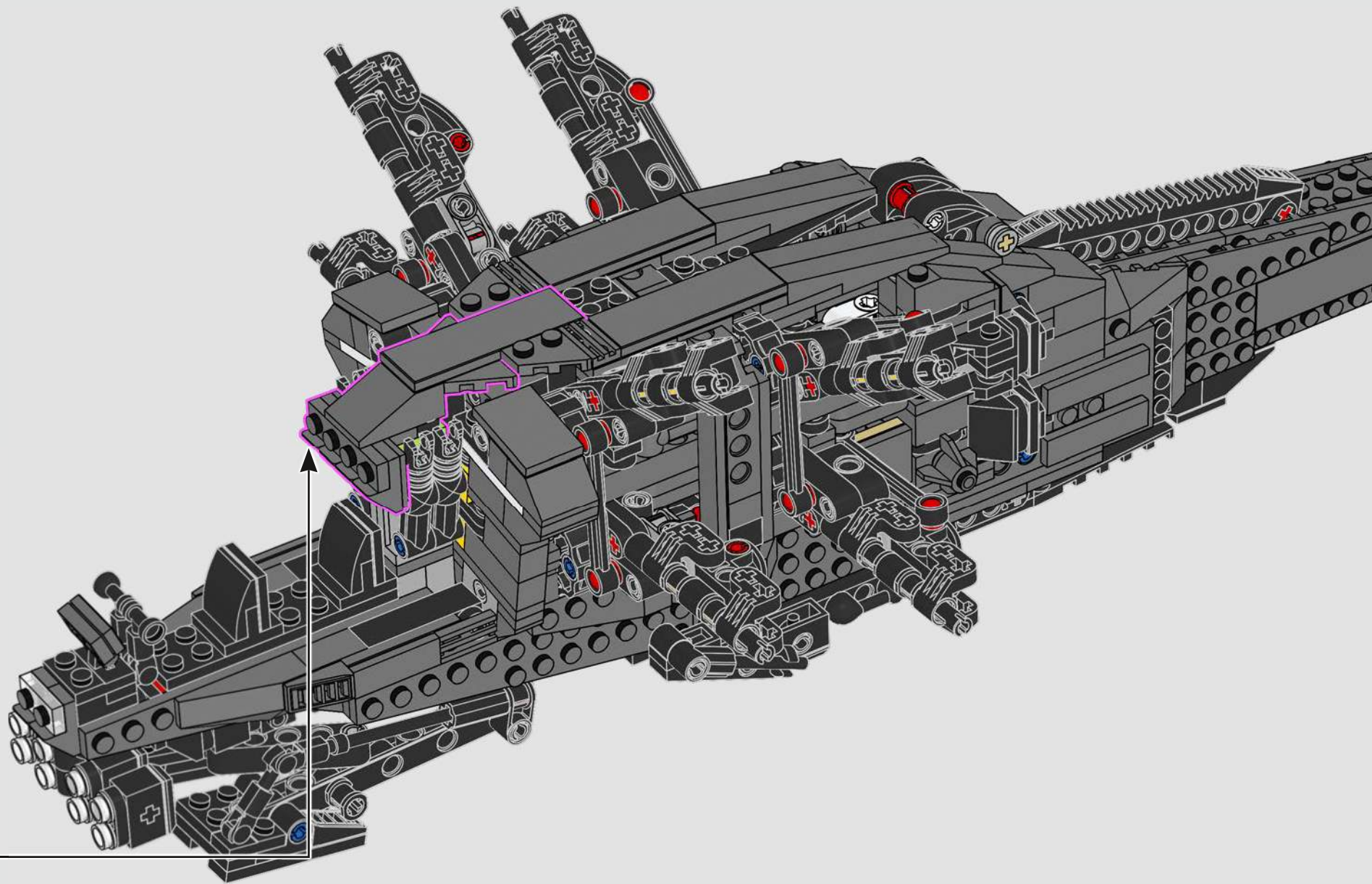

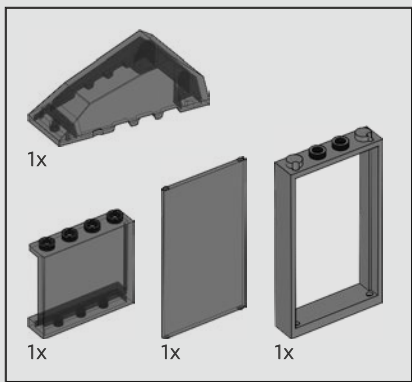

323

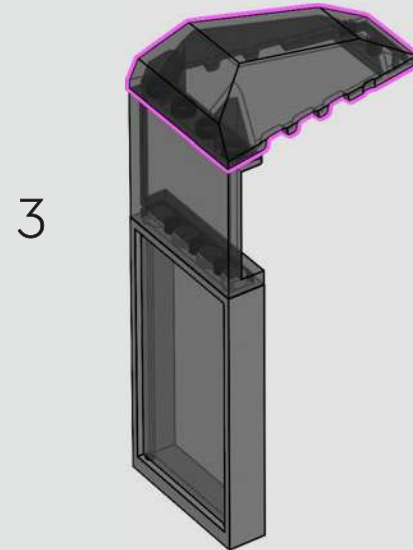
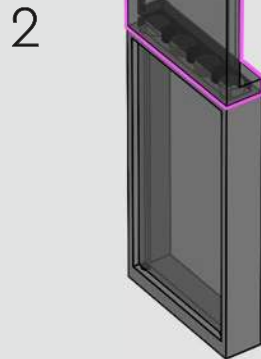
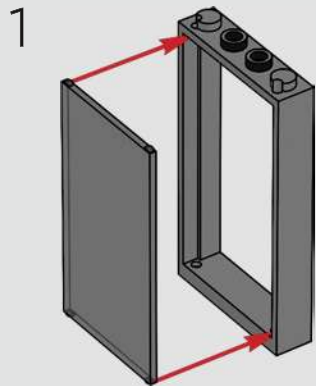



The cockpit is made very open to provide maximum visibility to the craft's pilot.

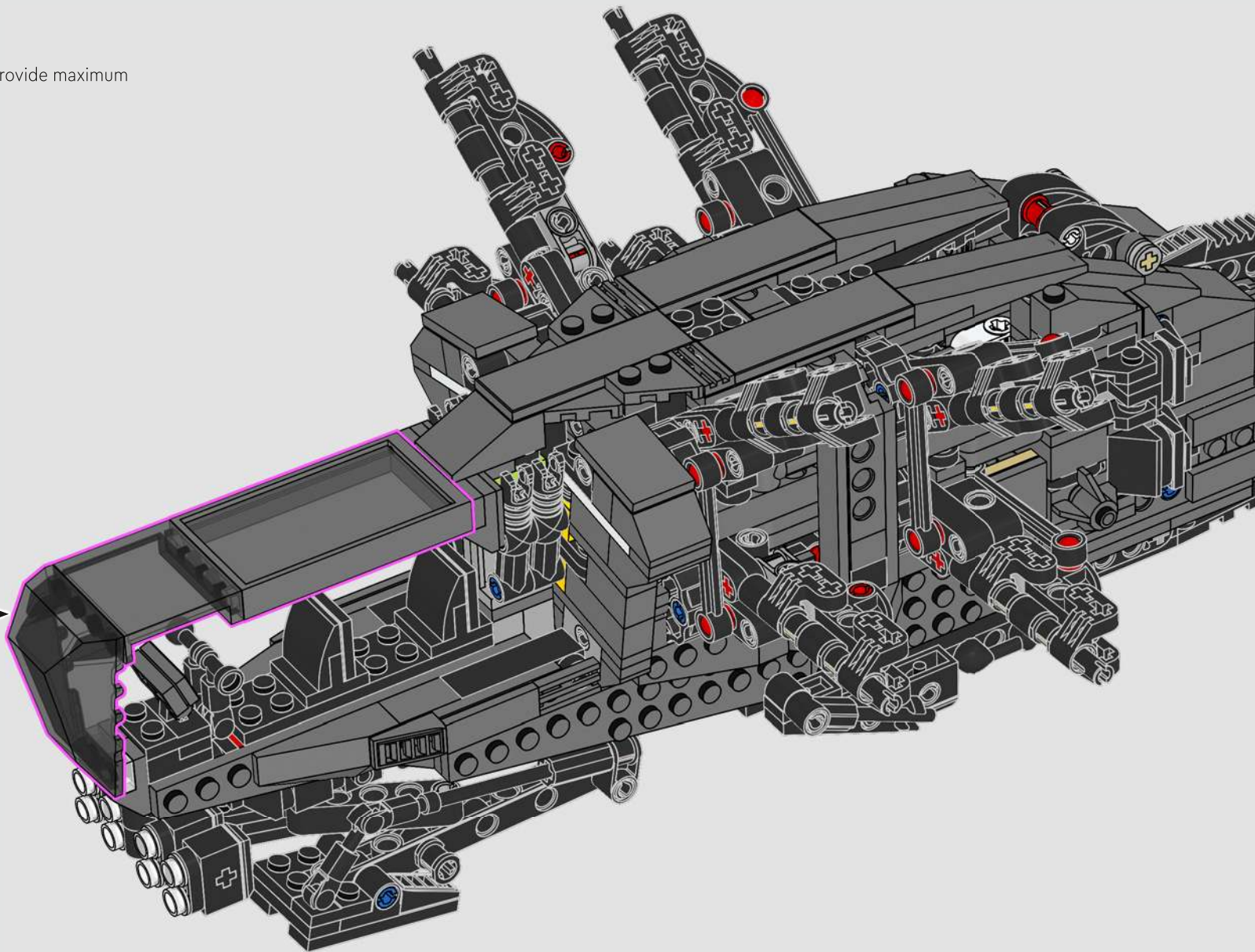

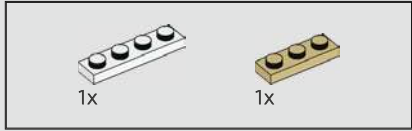
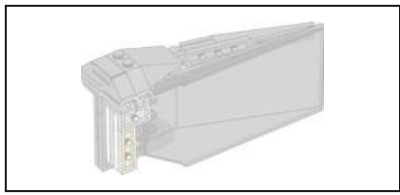

324

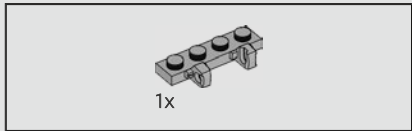
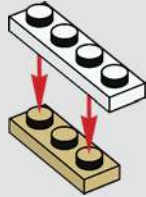

325

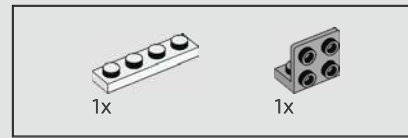
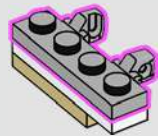

326

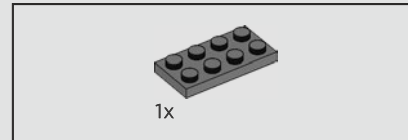
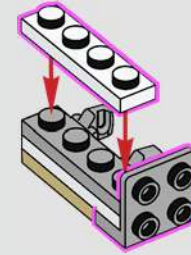

327

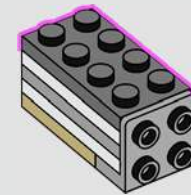

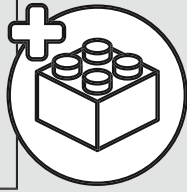
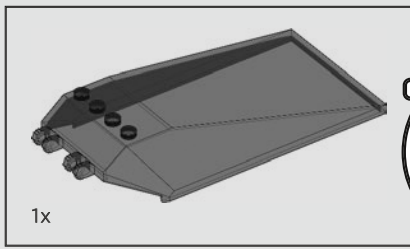

328

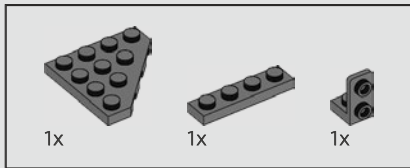
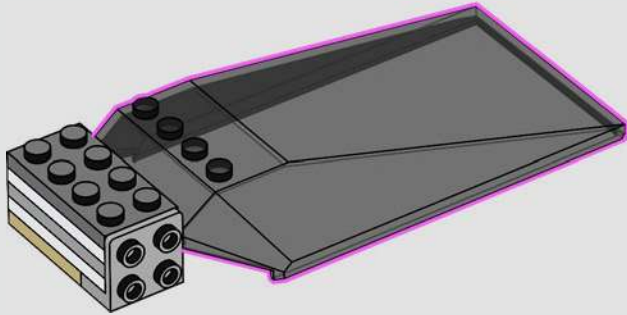

329

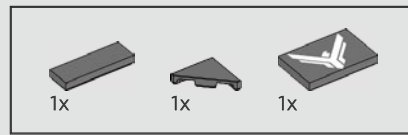
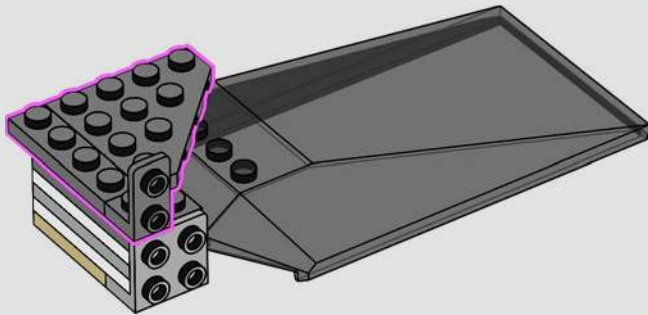

330

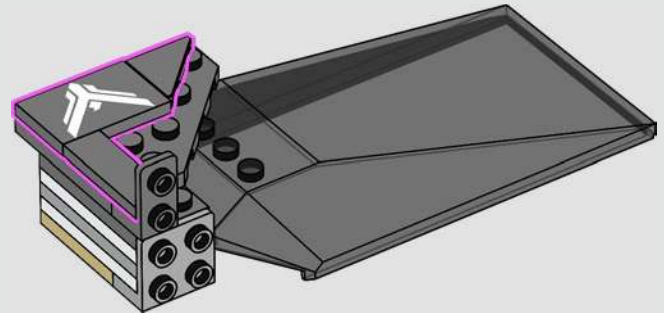

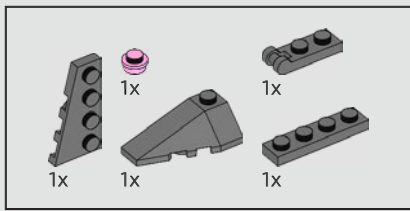

331

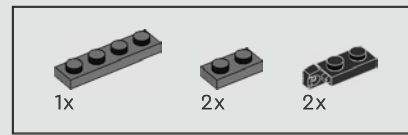
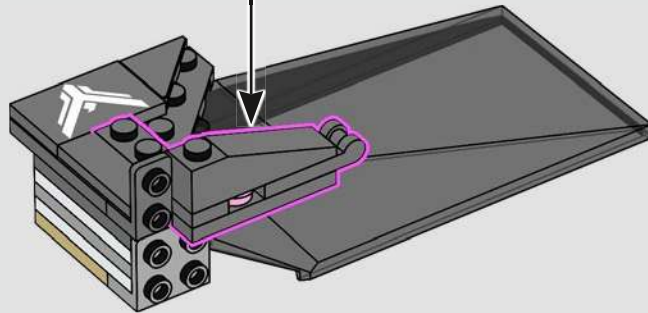
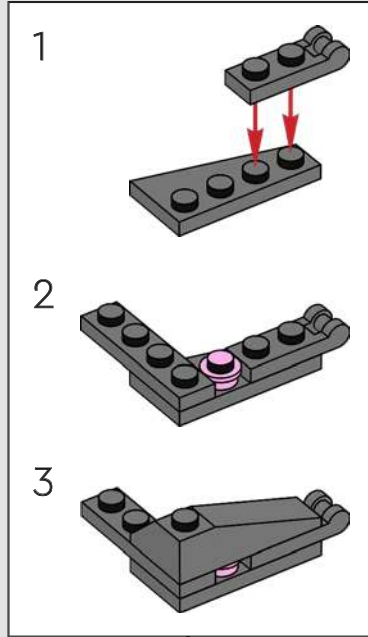

332

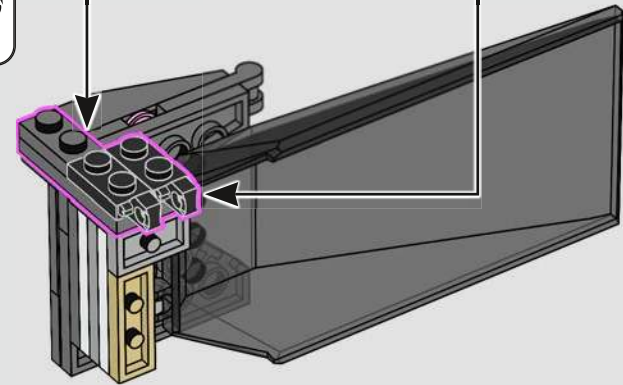
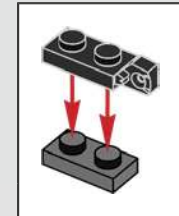
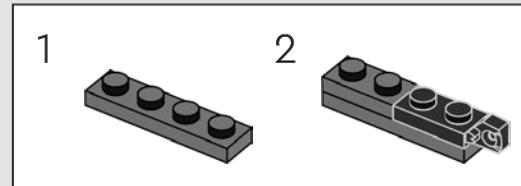

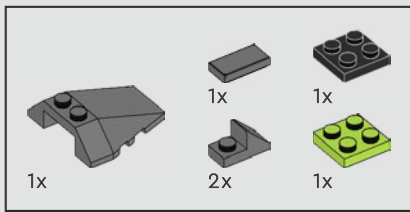

333

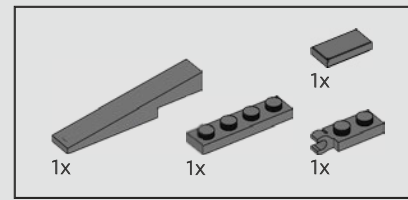
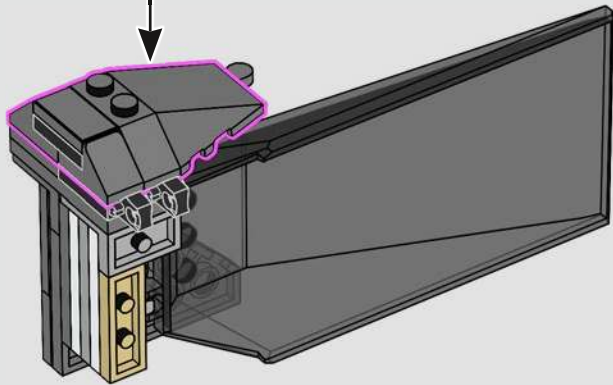
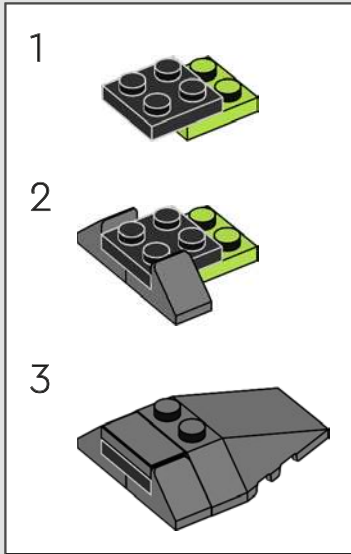

334

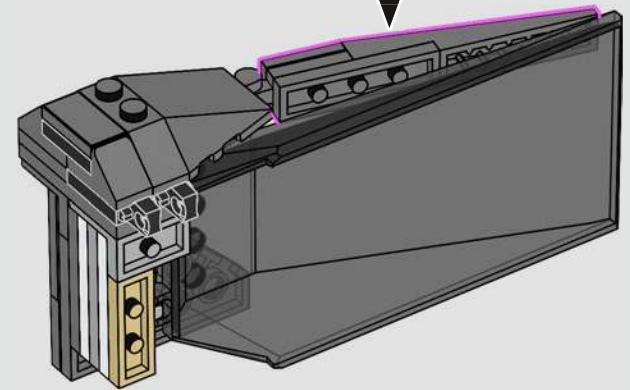
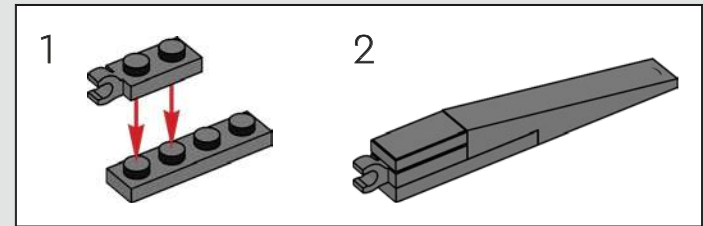

335

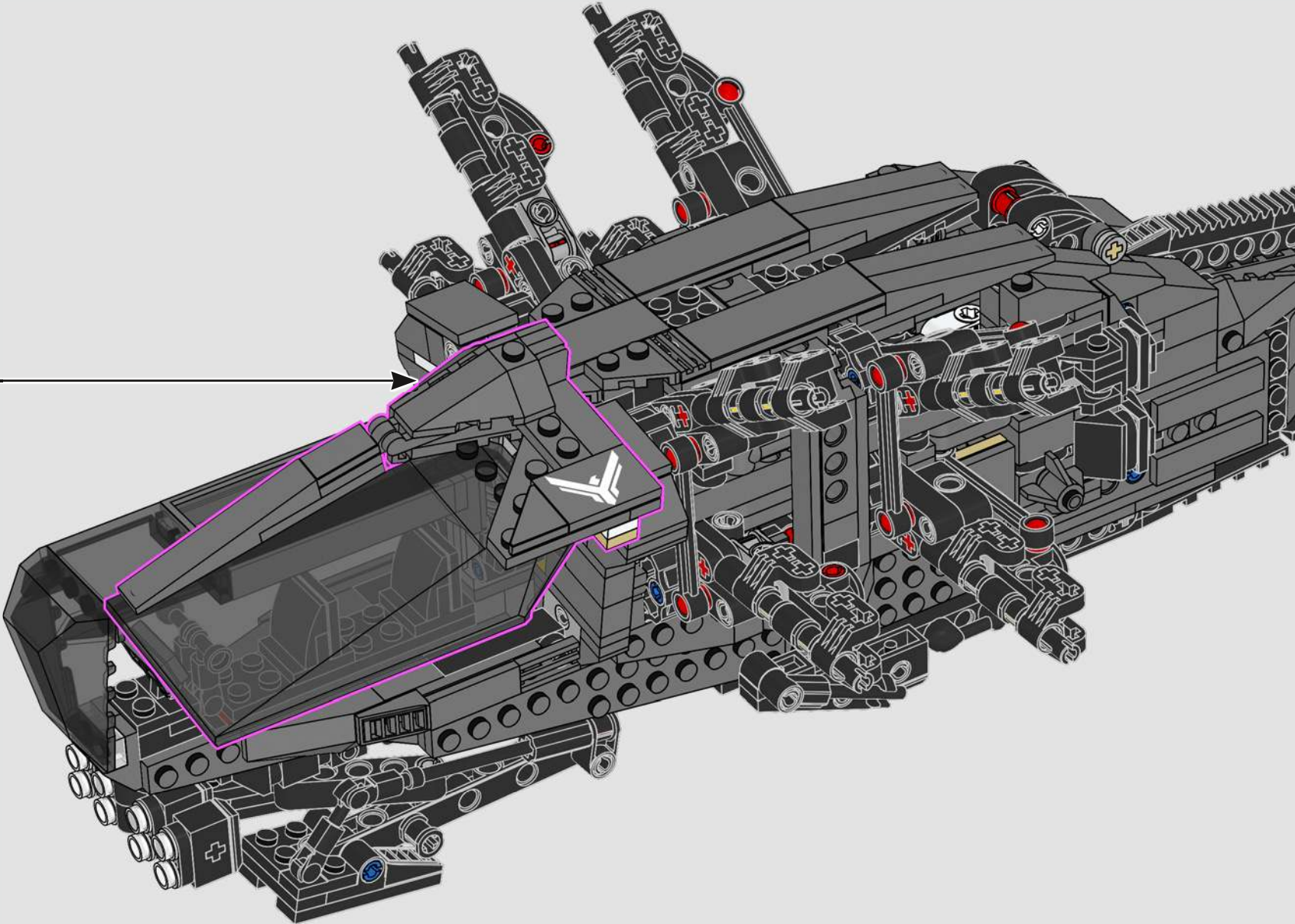

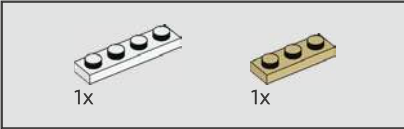
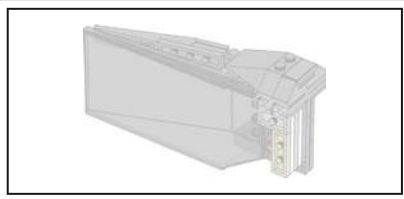

336

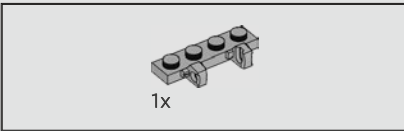
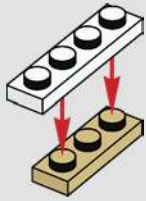

337

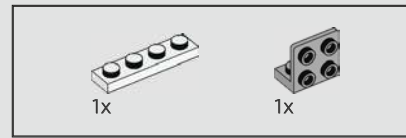
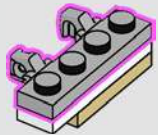

338

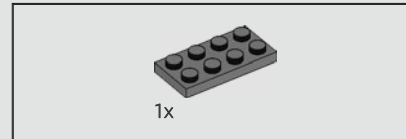
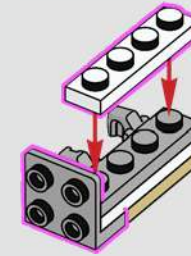

339

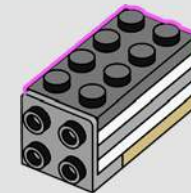

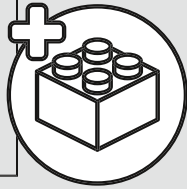
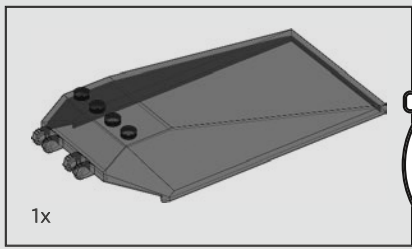

340

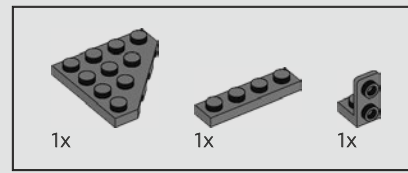
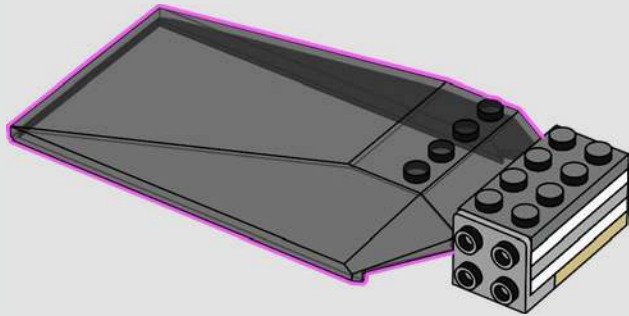

341

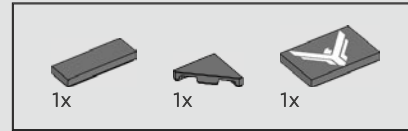
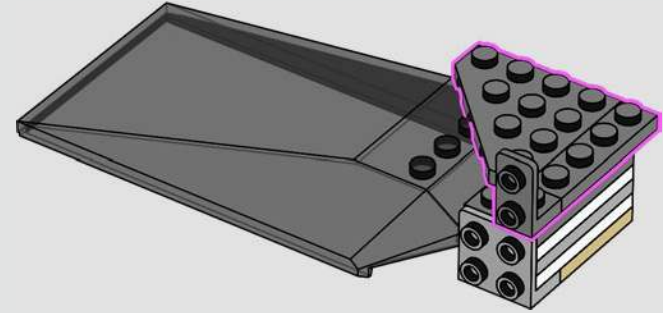

342

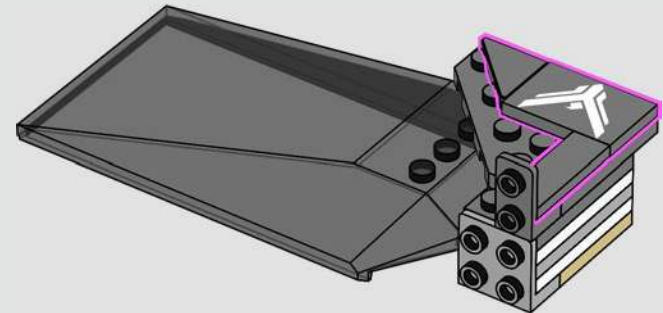

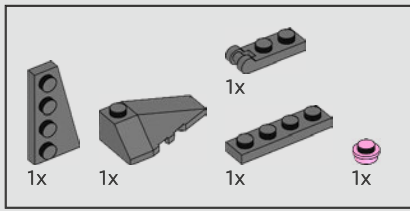

343

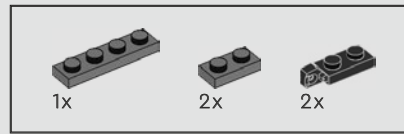
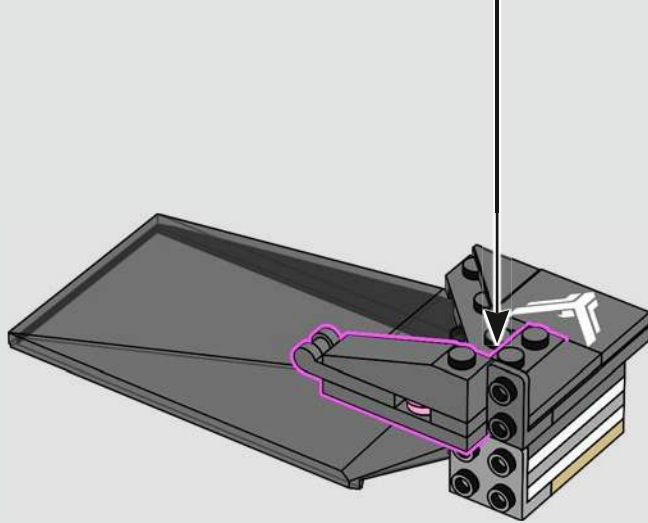
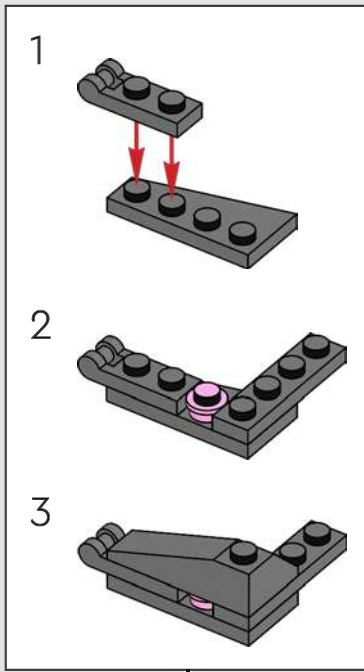

344

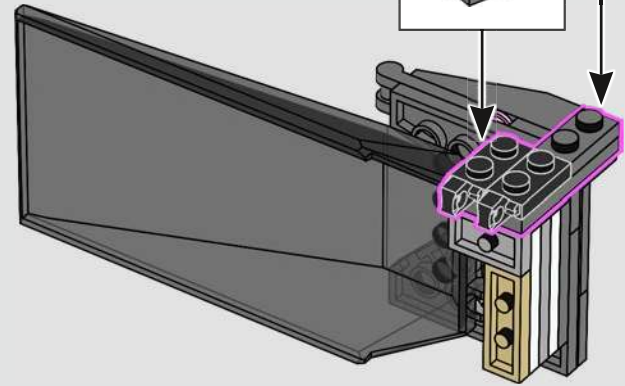
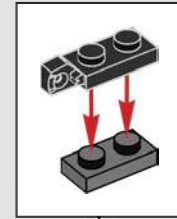
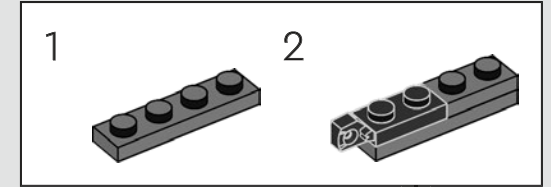

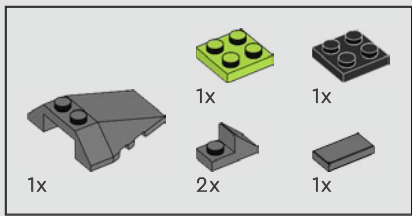

345

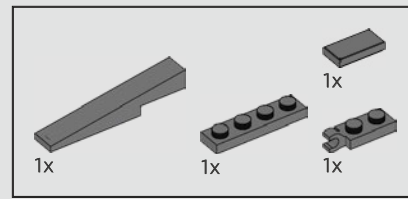
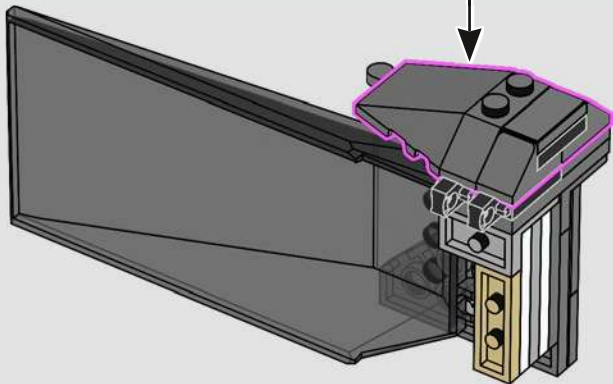
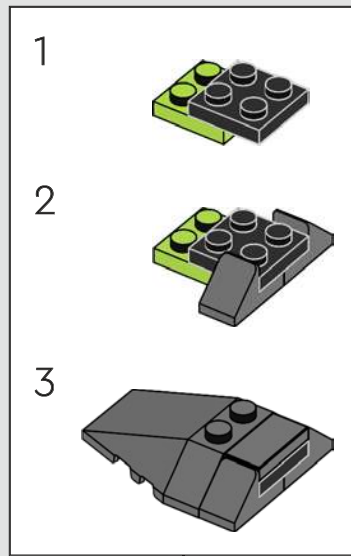

346

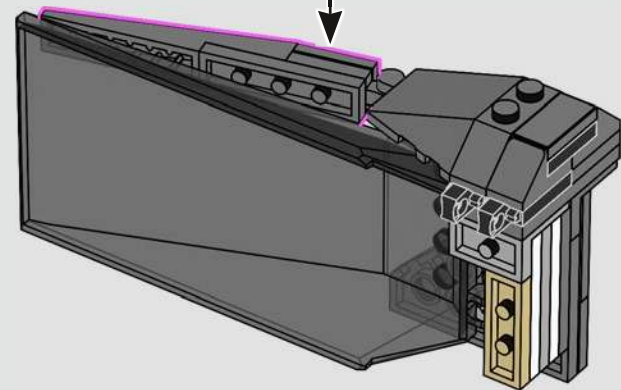
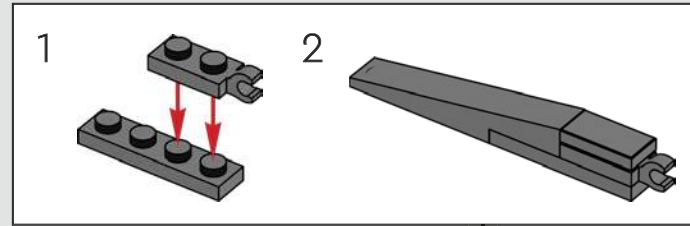

347

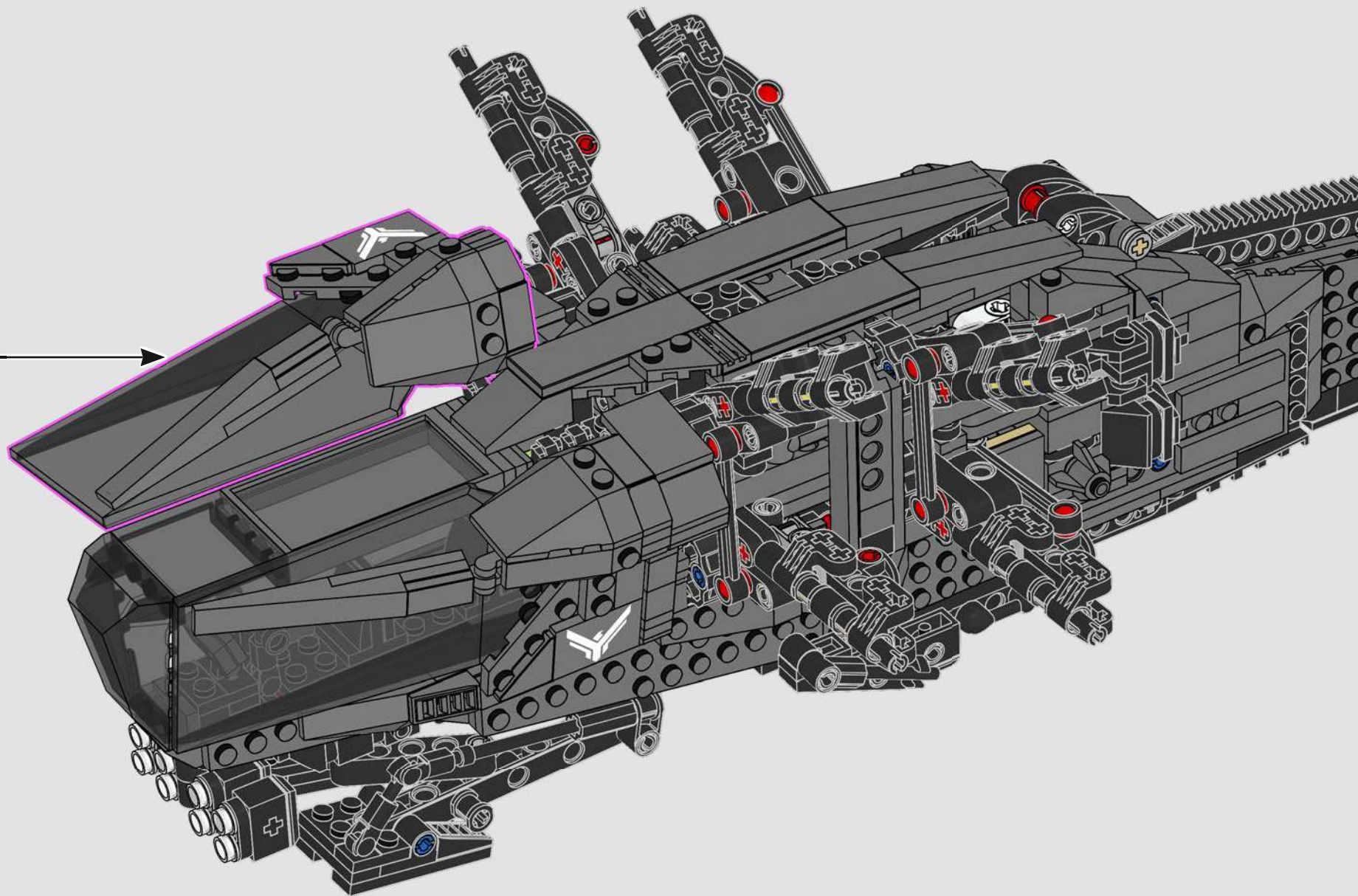



8x

348



8x

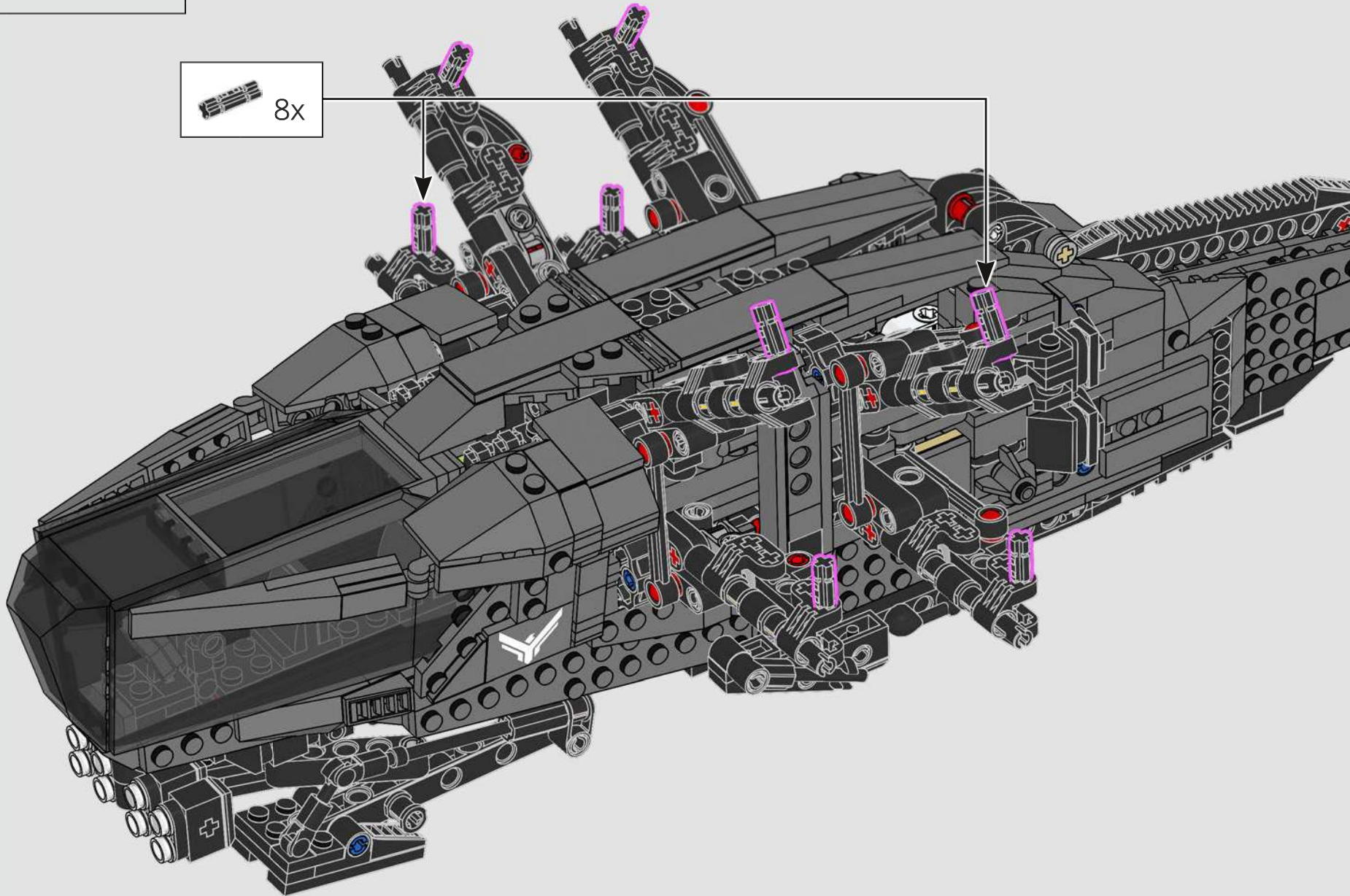

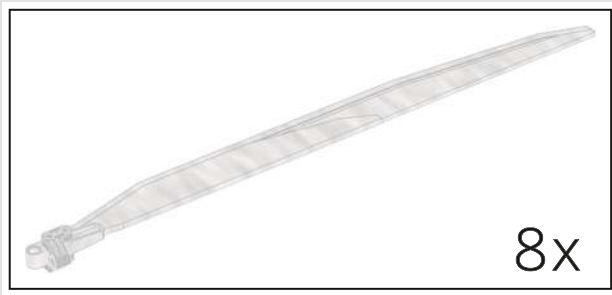

349

1



2



3

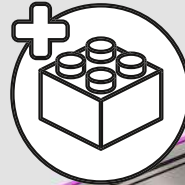

8x



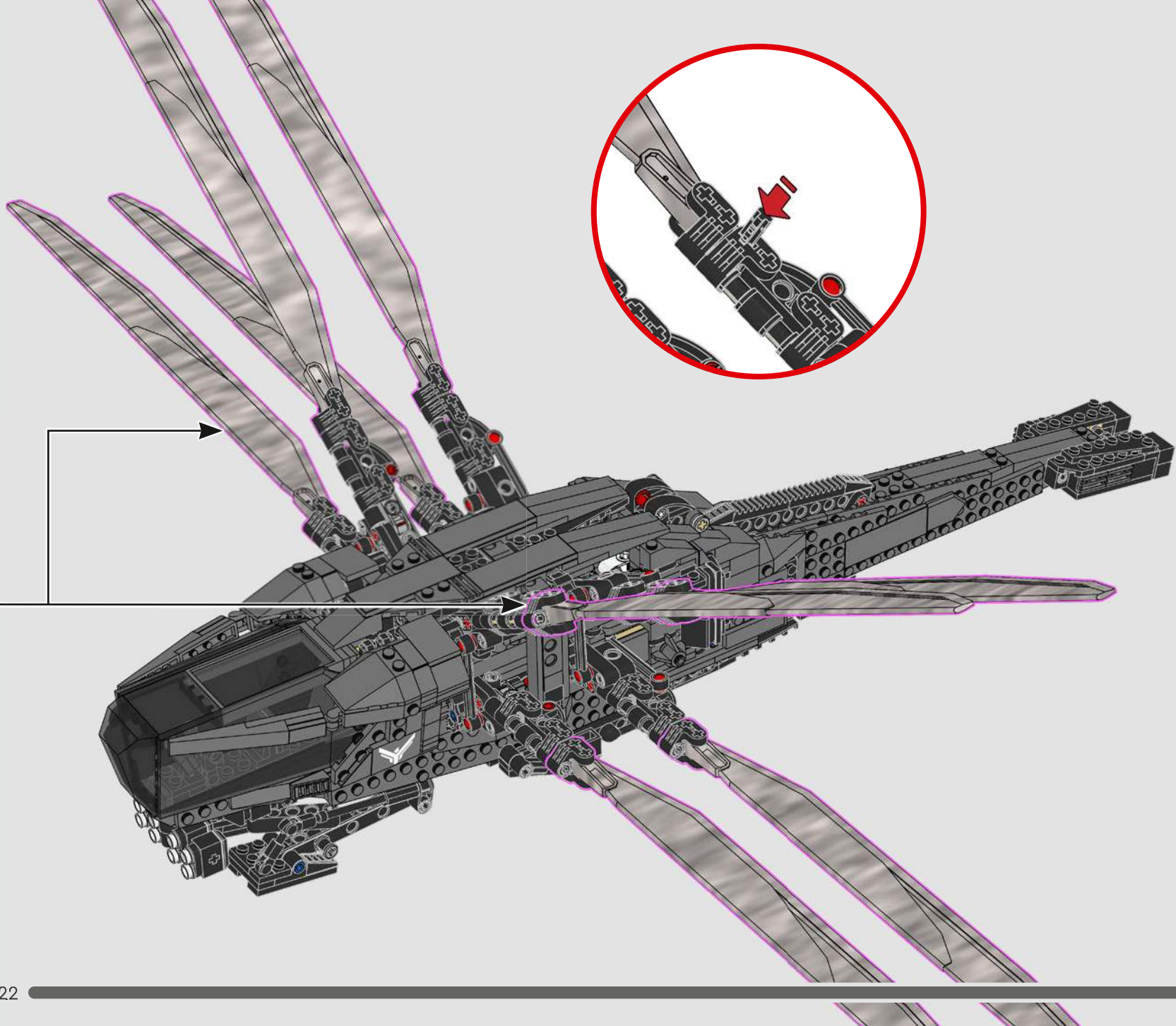

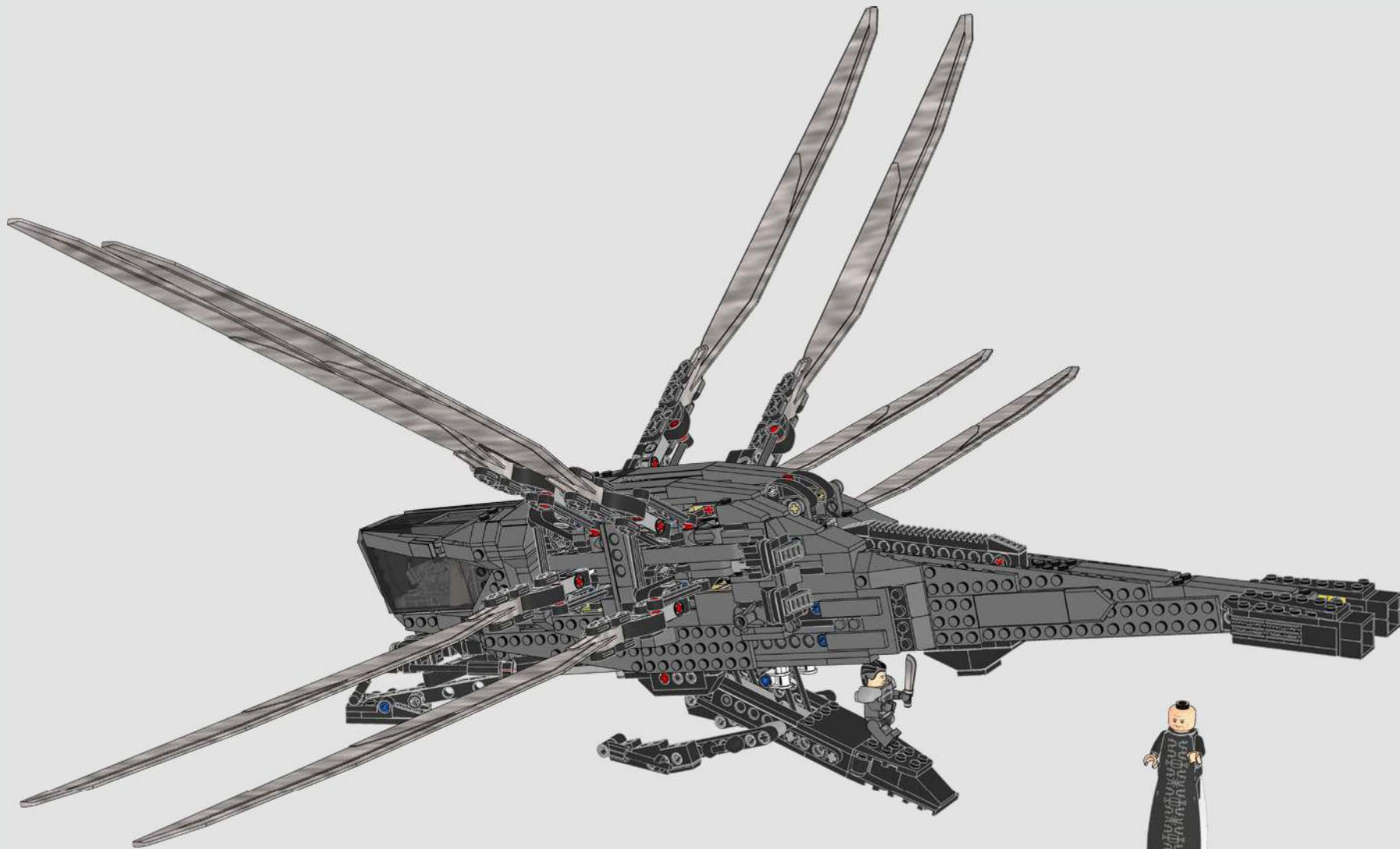

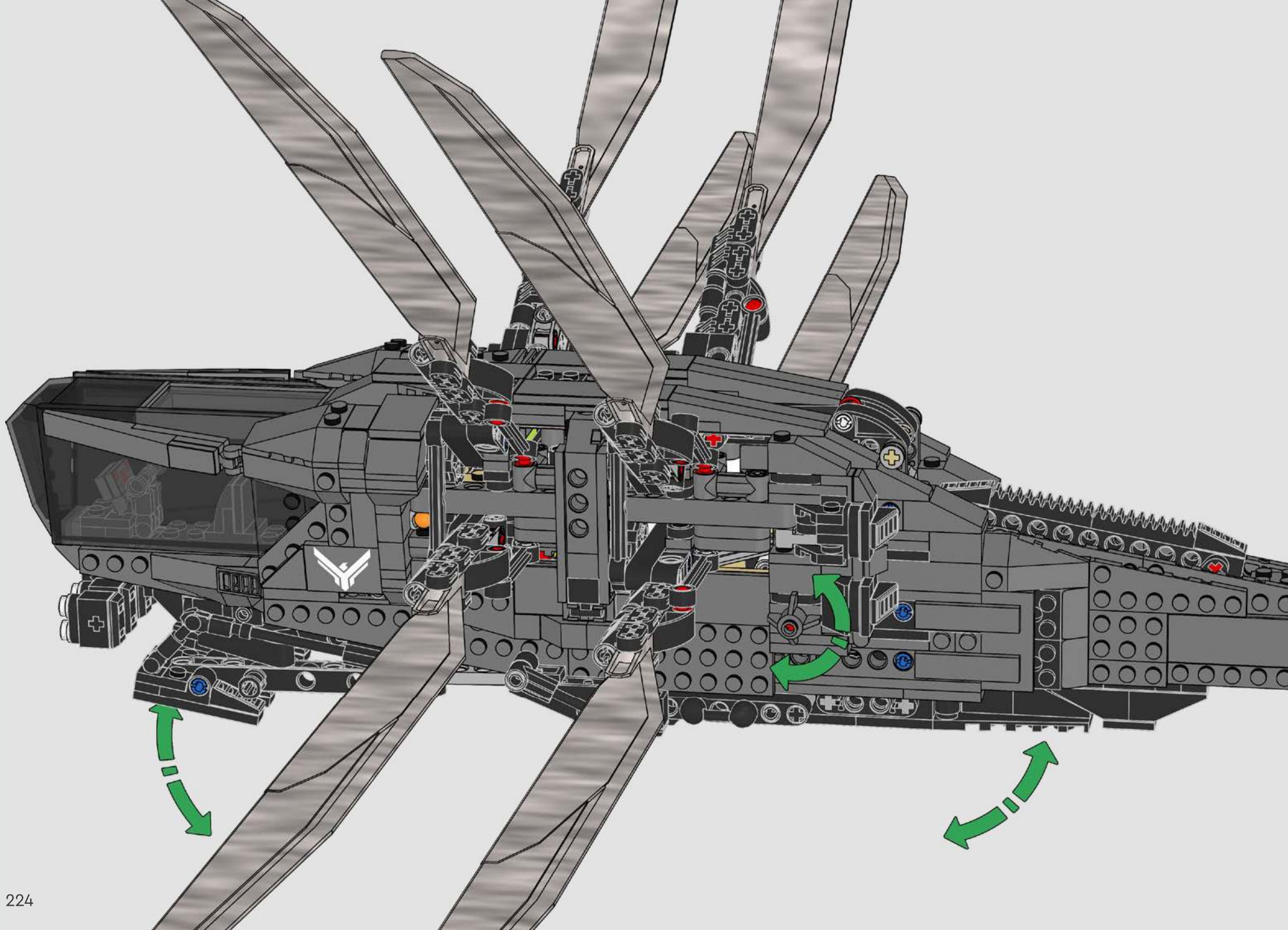

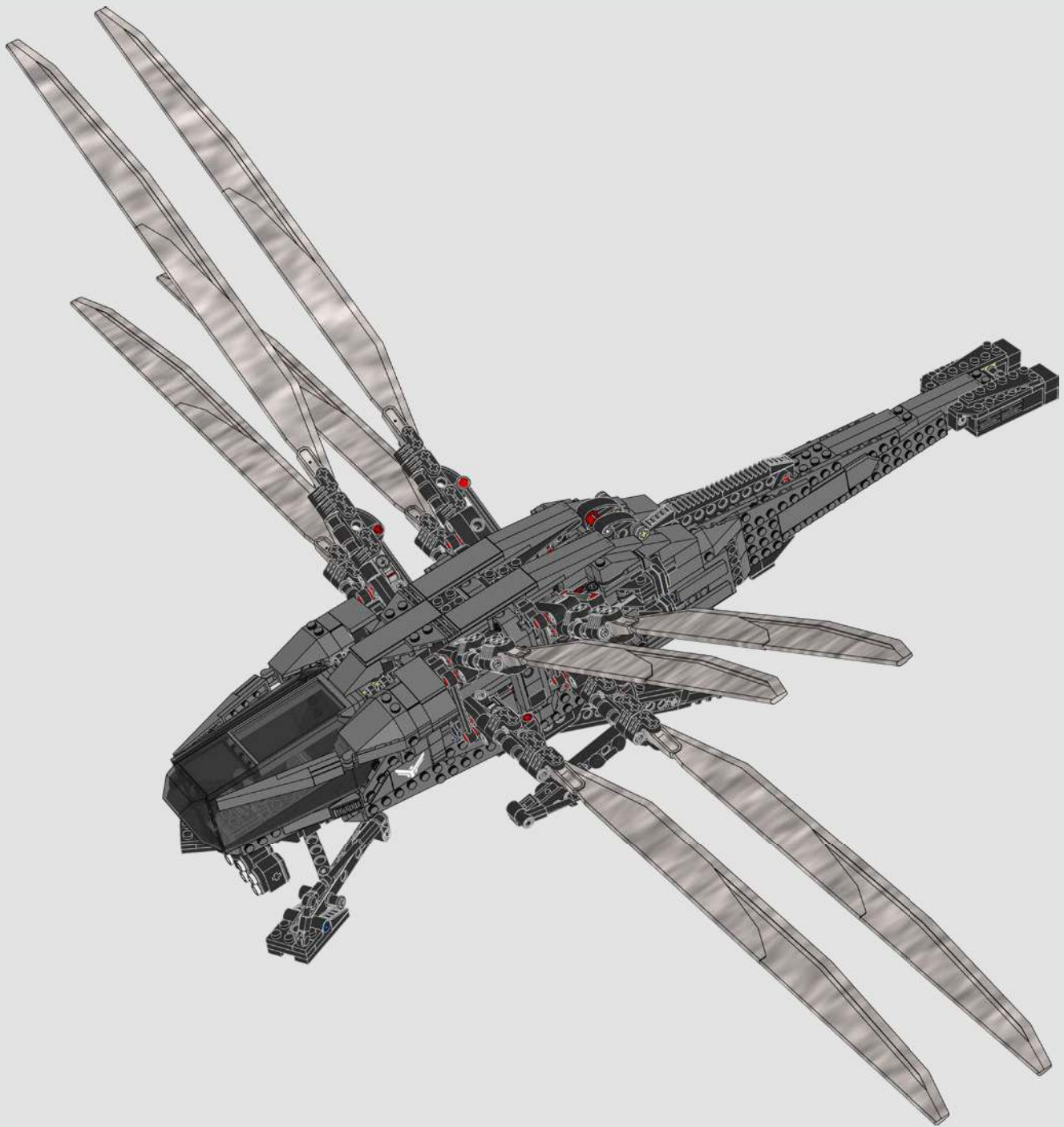

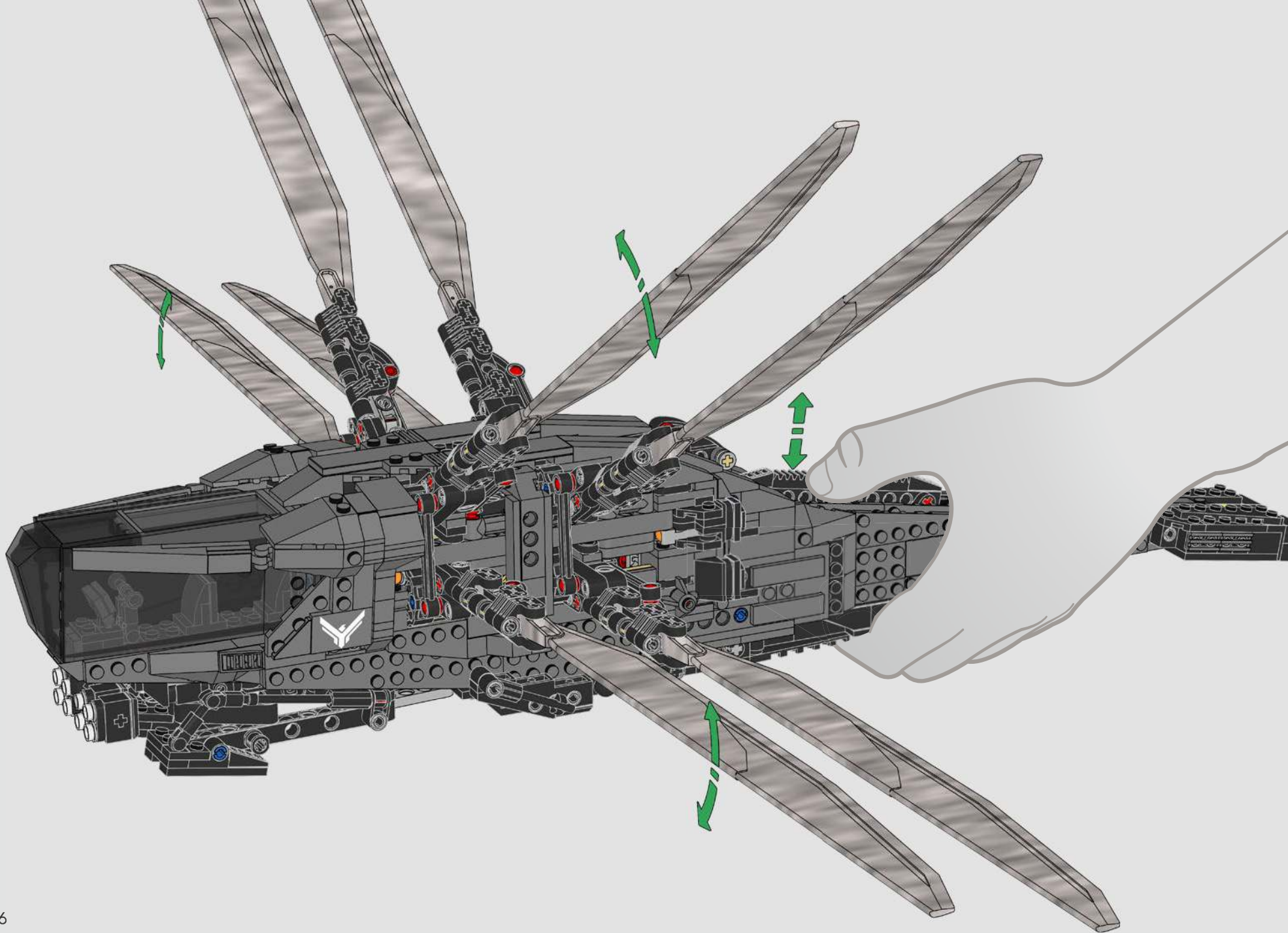

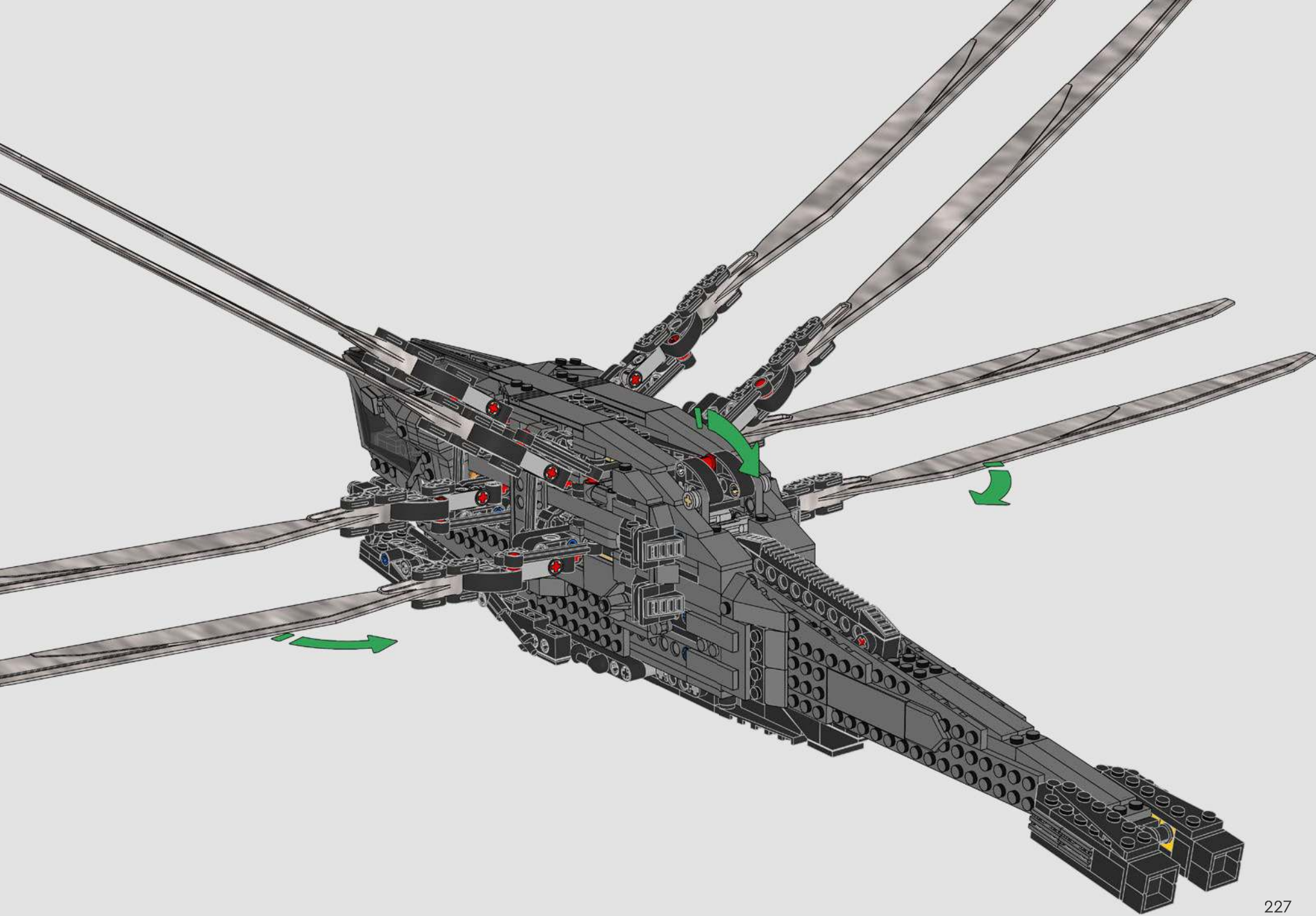

2x 6346389
5x 6058177
6x 6289797
4x 4208160
1x 6478175
1x 6480837
2x 6370532
10x 371001
2x 6360069
2x 389401
2x 6001831
4x 6013938
6x 4666579
1x 6117975

8x 4121921
4x 4118790
4x 4201062
5x 4550323
2x 4550324
1x 6186258
2x 4143409
7x 6271820
30x 6378120
20x 6360104
2x 6384112
31x 4142865
7x 300421
1x 6385920
2x 6271827

3x 6130002
1x 6335578
2x 379521
1x 6130005
7x 4206482
20x 6299413
4x 6271167
14x 654124
1x 6344181
8x 6130007
1x 6072627
2x 362224
2x 6170294

24x 614126
2x 306226
4x 6439039
6x 6284699
18x 6121485
2x 459926
8x 407026
2x 6170566
2x 6234695
2x 6299338
1x 6134617
1x 6055640
2x 6344427
60x 6210270
2x 6344428

2x 6338428
1x 6405548
3x 6261371
64x 6279875
5x 6271535
48x 4109810
8x 6282140
1x 6253260
2x 4512363
10x 6326047
1x 6280394
1x 9339
1x 6173119
10x 6114987
18x 6092585
6x 6174243

2x 302326
2x 6465248
1x 6266244
4x 6138173
6x 6156991
4x 6178922
10x 4541191
2x 4144024
1x 6146220
4x 6248496
2x 3200026
2x 6347310
2x 6192309
2x 6117973
1x 6310268

3x 6250020
1x 6276875
2x 6428168
2x 6151289
18x 6331723
4x 6266224
4x 6396457
24x 6279021
4x 6061032
2x 6265730
1x 303926
8x 302226
6x 242026
2x 306826
2x 6211476

1x 6013867
2x 235726
2x 6425507
1x 6365577
5x 6469445
19x 6321745
8x 6186133
8x 6477712
2x 362326
1x 6478958
2x 6435928
10x 6327548
2x 6116604
1x 329826

1x 370526
3x 370126
10x 371026
2x 301026
2x 6457282
2x 300126
2x 302026
8x 4142135
4x 6350415
1x 6256116
1x 6275401
2x 6170421
12x 4629921

1x 370626
5x 6039194
2x 4620763
2x 663626
2x 6311889
2x 6064228
1x 617926
1x 6414768
2x 379526
4x 4495935
1x 370726
4x 346026

9

3

10

5

7

8

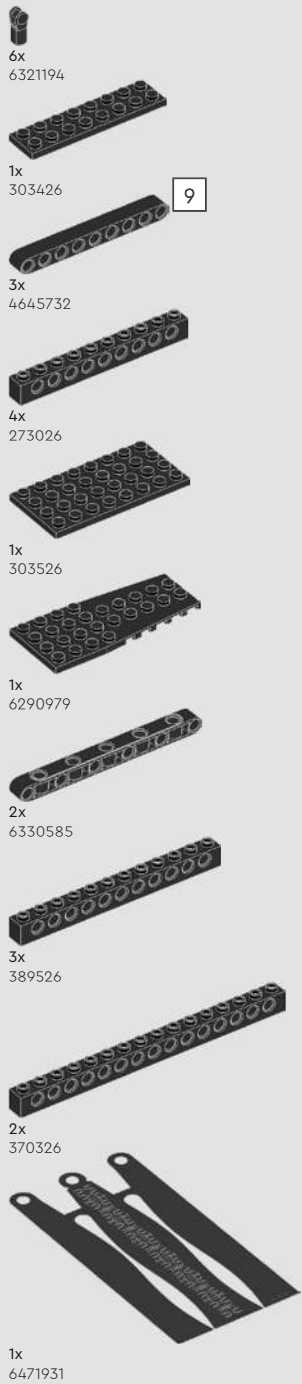

6x
6321194

1x
303426

3x
4645732

4x
273026

1x
303526

1x
303526

2x
6330585

3x
389526

2x
370326

1x
6471931

9

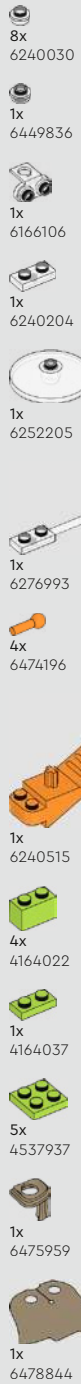

8x
6240030

1x
6449836

1x
6166106

1x
6240204

1x
6252205

1x
6276993

4x
6474196

1x
6240515

4x
4164022

1x
4164037

5x
4537937

1x
6475959

1x
6478844



2x
4226869

1x
6477704

4x
6271165

2x
4640844

3x
6275844

4x
6443149

1x
4550170

5x
6179186

10x
4211807

2x
6265089

1x
4211714

2x
6123809

8x
4211440



2x
4593679

2x
6173127

2x
4654580

2x
6331859

2x
6093527

8x
6273724

1x
4211815

4x
6043639

1x
6478014

2x
6273212

1x
4251163

2x
6276045

2x
4211639

2x
6170293

3

5



1x
4522934

1x
4211556

1x
6093515

8x
6296856

4x
4210719

4x
4211044

6x
4210848

4x
4504378

6x
4211098

4x
6336390

2x
6435043

1x
4542586

1x
6359369

2x
6331222

1x
6143423

13



1x
6143417

2x
6448323

2x
6448325

2x
4210788

2x
4210782

2x
6388119

4x
4567887

4x
6005331

2x
6388131

1x
6476887

2x
4211111

8x
4211063

3x
4210762



4x
6344754

8x
6019987

10x
6069164

9x
4210631

2x
4540386

4x
6168776

4x
6396058

4x
4211088

4x
4211052

1x
6342558

1x
6291791

2x
6308045

1x
6314192

2x
6262025

4x
6336990



3x
4586562

3x
4209014

14x
6271814

10x
4210635

4x
4211060

10x
4211094

2x
4211055

2x
6477380

2x
4211054

2x
4210862

8x
6015356



2x
4521187

2x
6335316

6x
4568734

10x
4211133

8x
4211045

2x
4211104

1x
6324639

1x
6478101

1x
6118832

1x
4527082

13x
4211043

3x
4211106

4x
6187008

2x
6476888

4

9x
6083620



1x
6271830



16x
4211001



5x
4211053



2x
4210728



3x
4210867



2x
6185675

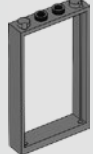

1x
6262942



6x
4211065



3x
4210866



2x
6307616

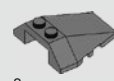

2x
6356488



16x
4211056



2x
4211100

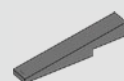

10x
6470155

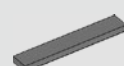

3x
4210651

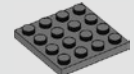

2x
4243831



5x
6321746



4x
4211002



1x
4210875

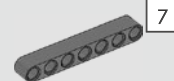

1x
4495931



2x
6477164

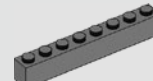

2x
4211099



2x
4211061



6x
6133611



2x
4211137

7

2x
4517996



1x
6476885



1x
6476878



1x
6476889



1x
6476894



1x
6473094



2x
4542576

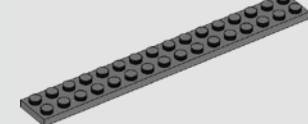

3x
4210796



1x
6476884



1x
6476891



1x
6478104



1x
6478066



1x
6093516

15

1x
6476883



1x
6399909



2x
6483955



2x
6270108



3x
6476882



3x
6477888



8x
6463040



1x
6473942



1x
6473942



1x
6473942



1x
6473942



1x
6467819

1x
6476892



1x
6476880



1x
6463049



2x
6473943



2x
6473943



LEGO.com/service



YOU COULD WIN



YOU COULD WIN

Your feedback will help shape the future development of this product series.

Visit:

DU KÖNNTEST GEWINNEN

Dein Feedback trägt zur Weiterentwicklung dieser Produktreihe bei.

Geh auf:

VOUS POURRIEZ GAGNER

Vos commentaires nous aideront à concevoir les futurs produits de cette gamme.

Visitez :

POTRESTI VINCERE TU

La tua opinione ci aiuterà a migliorare la creazione futura di questa linea di prodotti.

Visita:

PUEDES GANAR

Tu opinión contribuirá al futuro de esta serie de productos.

Visita:

轻松获奖

您的反馈将有助于我们在今后改进本产品系列。

请访问:

[LEGO.com/productfeedback](https://www.lego.com/productfeedback)

You also have the chance to win a LEGO® set.

Terms and conditions apply.*

Außerdem hast du die Chance, ein LEGO® Set zu gewinnen.

Es gelten die Teilnahmebedingungen.*

Vous pourriez également gagner un ensemble LEGO®.

Des conditions s'appliquent.*

Hai anche la possibilità di vincere un set LEGO®.

Termini e condizioni sono applicabili.*

También tienes la oportunidad de ganar un set LEGO®.

Aplican términos y condiciones.*

您还有机会赢取乐高®套装。

条款和条件适用。*

*[LEGO.com/productfeedback-terms](https://www.lego.com/productfeedback-terms)



LEGO and the LEGO logo are trademarks of the LEGO Group.
©2024 The LEGO Group. 6562106
© 2024 Legendary. All Rights Reserved.