

de - Montageplan für integrierte Geschirrspüler

Bitte beachten Sie diesen Montageplan und lesen Sie unbedingt die Gebrauchsanweisung vor der Aufstellung - Installation - Inbetriebnahme. Dadurch schützen Sie sich und vermeiden Schäden an Ihrem Gerät.

en - Installation drawings for semi-integrated dishwashers

To avoid the risk of accidents or damage to the dishwasher please observe this installation sheet and read the operating instruction manual supplied with it before it is installed or used for the first time.

fr - Notice de montage pour lave-vaisselle intégrables

Pour votre sécurité et afin d'éviter d'endommager votre appareil, veuillez suivre les indications de cette notice et lire le mode d'emploi avant de monter, d'installer ou de mettre en service votre lave-vaisselle.

nl - Installatietekening voor geïntegreerde vaatwassers

Bekijk dit montageschema en lees de gebruiksaanwijzing voordat u uw apparaat plaatst, installeert en in gebruik neemt. Dat is veiliger voor uzelf en u voorkomt daarmee onnodige schade aan uw apparaat.

it - Schema di montaggio per lavastoviglie integrabili

Prima di installare e mettere in funzione la lavastoviglie, leggere assolutamente le istruzioni per l'uso e attenersi a questo schema di montaggio per evitare di farsi male o di danneggiare l'elettrodomestico.

es - Plano de montaje para lavavajillas integrables

Le agradecemos su confianza y esperamos disfrute de su nuevo aparato. Para ello es imprescindible, antes de su emplazamiento, instalación y puesta en marcha, tener en cuenta este esquema de montaje y leer las instrucciones de manejo, para evitar daños tanto al usuario, como al aparato.

pt - Plano de montagem para máquina de lavar louça de integrar

Observe este plano de montagem e leia as instruções de utilização antes de instalar, ligar e iniciar o funcionamento com a máquina. Desta forma não só se protege como evita anomalias no seu aparelho.

tr - Ankastre Bulaşık Makinesi Montaj Planı

Bu montaj planını dikkate alınız ve cihazı kurmadan ve çalistirmadan önce kullanma kilavuzunu mutlaka okuyunuz.

el - Σχεδιάγραμμα τοποθέτησης για εντοιχίζόμενα πλυντήρια πιάτων

Λάβετε υπόψη σας αυτό το σχεδιάγραμμα τοποθέτησης και διαβάστε οπωσδήποτε τις οδηγίες χρήσης, πριν από την τοποθέτηση - σύνδεση - αρχική λειτουργία. Έτσι προστατεύετε τον εαυτό σας και αποφεύγετε πιθανές βλάβες στη συσκευή.

hr - Načrt za montažu integrirane perilice posuđa

Prije postavljanja - ugradnje - prve uporabe obvezno pročitatje upute za uporabu i pridržavajte se načrta za montažu. Time ćete zaštititi sebe i izbjeći oštećenja uređaja.

sl - Montažni načrt za vgradni pomivalni stroj

Pred namestitvijo in prvo uporabo pomivalnega stroja morate najprej prebrati priložena navodila za uporabo in tako preprečiti poškodbe ljudi in pomivalnega stroja.



Gebrauchsanweisung beachten.

See operating instruction manual.

Lisez le mode d'emploi.

Neem de gebruiksaanwijzing in acht.

Attenersi alle istruzioni d'uso.

Tenga en cuenta las instrucciones de manejo.

Observe o indicado no livro de instruções.

Kullanma kilavuzunu dikkate alınız.

Διαβάστε τις οδηγίες χρήσης.

Pridržavajte se uputa za uporabu.

Preberite navodila za uporabo.



Beschädigung oder Brandgefahr.

Risk of damage or fire hazard.

Risque de dommages ou d'incendie.

Gevaar voor schade of brand.

Attenzione: pericolo di danneggiamento o di incendio.

Daños o riesgo de incendio.

Risco de avarias ou de incêndio.

Hasar vey a yangin tehlikesi.

Κίνδυνος ζημιάς ή φωτιάς.

Opasnost od oštećenja ili požara.

Nevarnost škode ali požara.



Anschlusswerte beachten.

Check connection data.

Respectez les valeurs de raccordement.

Neem de aansluitwaarden in acht.

Controllare i valori di allacciamento.

Aténgase a los valores de conexión.

Observe os valores para a ligação.

Bağlantı değerlerine dikkat ediniz.

Προσοχή στην ισχύ ηλεκτρικής σύνδεσης.

Pridržavajte se priključnih vrijednosti.

Provjerite priključne vrijednosti uređaja.

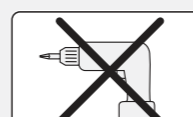

Keinen Akkuschräuber verwenden, Beschädigungsgefahr.

Do not use a cordless screwdriver, risk of damage.

N'utilisez pas de visseuse électrique, risque de dommages.

Gebruik geen accuschroevendraaier. Kans op beschadiging.

Non utilizzare un avvitatore a batteria, pericolo di danneggiamento.

No utilizar destornillador automático, peligro de sufrir daños.

Não usar aparafusadoras sem fios, risco de danos.

Şarjlı tornavida kullanmayınız, hasar tehlikesi.

Μη χρησιμοποιήσετε κατσαβίδι Akku, κίνδυνος ζημιάς.

Nemojte koristiti akumulatorski odvijač, opasnost od oštećenja.

Ne uporabljajte akumulatorskega vijačnika – nevarnost poškodbe.



Achtung Schnittgefahr.

Warning: Danger of being cut.

Attention. Risque de blessure par coupure.

Pas op. Snijgevaar.

Attenzione, pericolo di tagliarsi.

Atención. Peligro de cortes.

Atenção. Risco de ferimentos por corte.

Dikkat Kesik Tehlikesi.

Προσοχή. Κίνδυνος τραυματισμού.

Pažnja: opasnost od posjekotina.

Pozor: nevarnost ureznin.



Das minimale/maximale Frontplattengewicht finden Sie unter den Technischen Daten Ihres Geschirrspülers auf der Miele Internetseite.

The minimum/maximum weight of the front panel is quoted in the technical data for your dishwasher on the Miele website.

Vous trouverez le poids minimal/maximal du panneau de façade dans les caractéristiques techniques de votre lave-vaisselle sur le site Internet de Miele.

Het minimale/maximale gewicht van de frontplaat vindt u bij de technische gegevens van uw vaatwasser op de website van Miele.

Il peso minimo/massimo relativo al pannello frontale è indicato sotto i dati tecnici della lavastoviglie, sul sito internet di Miele.

El peso mínimo/máximo del panel frontal se puede encontrar en los datos técnicos del lavavajillas en la página web de Miele.

Pode encontrar o peso mínimo/máximo dos painéis frontais nas características técnicas da sua máquina de lavar louça no site da Miele.

Minimum/maksimum ön panel ağırlığını, Miele web sitesinde, bulaşık makinesinin teknik verilerinde bulabilirsiniz.

Μπορείτε να βρείτε το ελάχιστο/μέγιστο βάρος πρόσωσης στο τεχνικά χαρακτηριστικά του πλυντήριου πιάτων σας, στην ιστοσελίδα της Miele.

Minimalnu/maksimalnu težinu prednje ploče pronaći ćete u tehničkim podacima svoje perilice posuđa na Miele internet stranici.

Minimalna/maksimalna teža srednje plošče je navedena pod tehničnimi podatki pomivalnega stroja na spletni strani Miele.



Türfedern nach Montage der Frontplatte unbedingt auf beiden Seiten gleichmäßig einstellen.

The door springs must be set equally on both sides after fitting the front panel to the door.

Les ressorts de porte doivent impérativement être réglés de la même façon des deux côtés après le montage de la plaque d'habillage.

Het is beslist noodzakelijk dat u de deuren van na de montage van het frontpaneel aan beide kanten gelijkmatig instelt.

Dopo aver montato il pannello frontale, regolare assolutamente le molle dello sportello su entrambi i lati affinché siano uguali.

Después del montaje del aparato, ajustar equibradamente los muelles de la puerta a ambos lados.

Após montagem do painel frontal, regular as molas da porta uniformemente de ambos os lados.

Ön kapak takıldktan sonra kapak yayları her iki tarafta da mutlaka eşit ayarlanmalıdır.

Μετά την τοποθέτηση της διακοσμητικής πόρτας, ρυθμίζετε οπωσδήποτε τα ελατήρια πόρτας ομοιόμορφα και από τις δύο πλευρές της.

Nakon montaže prednje ploče, opruge vrata moraju biti ravnomjerno podešene na obje strane.

Na obeh straneh uravnajte tečaj vrat.



Vor dem Verschieben des Geschirrspülers Füße eindrehen.

Screw the feet in before moving the dishwasher.

Faire entrer les pieds en les vissant avant de déplacer le lave-vaisselle.

Draai de stelvoeten naar binnen voordat u de vaatwasser verschuift.

Avvitare i piedini prima di muovere la lavastoviglie.

Antes de deslizar el lavavajillas, atornillar las patas.

Antes de deslocar a máquina de lavar louça deve enroscar os pés.

Bulaşık makinesini yerinden oynatmadan önce vidalı ayakları içeri çeviriniz.

Πριν μετακινήσετε το πλυντήριο πιάτων βιδώστε τα πόδια του.

Prije pomicanja perilice posuđa zavrnite nožice uređaja.

Noge privijte pred premikanjem pomivalnega stroja!

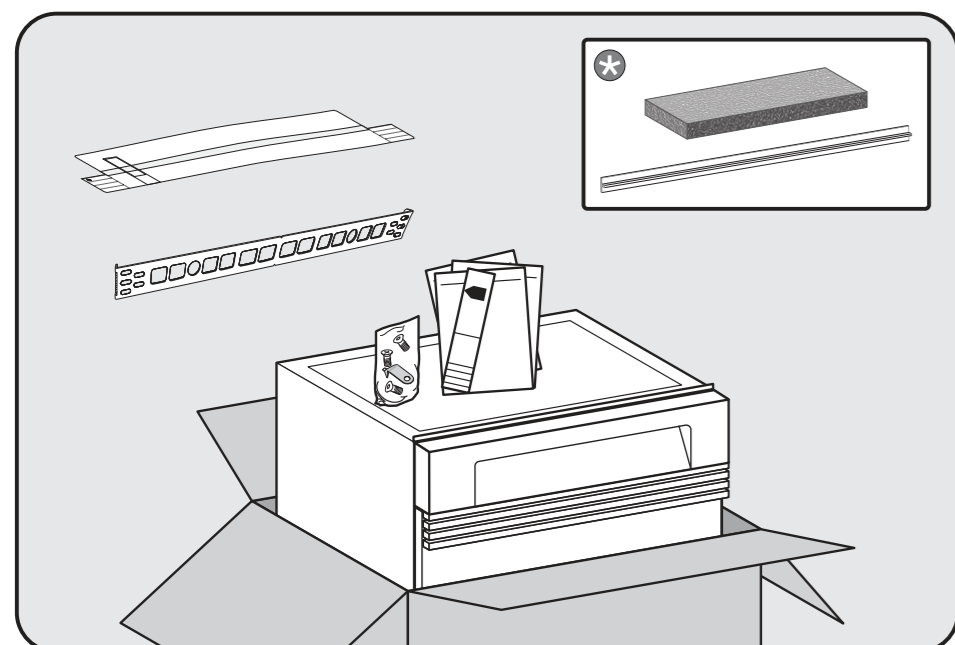

Je nach Modell beliegendes Montagezubehör.
Fittings supplied depend on model.
Accessoires fournis selon modèle.
Voor het desbetreffende model meegeleverde benodigde onderdelen.
Accessori di montaggio in dotazione, a seconda del modello.
Según el modelo, accesorios de montaje suministrados.

De acordo com o modelo, acessórios de montagem fornecidos junto.
Modelo bağı olarak verilen montaj parçaları.
Συνοδευτικό εξοπλισμό τοποθέτησης ανάλογα με το μοντέλο.
Dle modelu přiložený montážní materiál.
Priložena oprema za montažo, odvisna od modela.

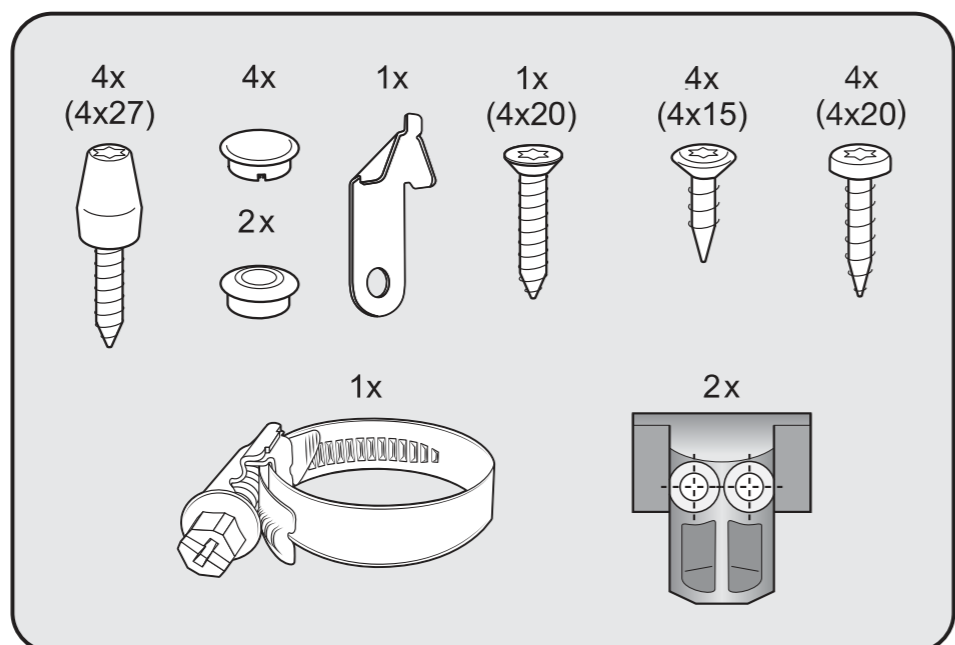

Je nach Modell benötigtes Werkzeug.
Tools required depend on model.
Matériaux requis selon modèle.
Voor het desbetreffende model benodigd gereedschap.
Utensili necessari, a seconda del modello.
Según el modelo, herramienta necesaria.
De acordo com o modelo, ferramentas necessárias.
Modelo bağı olarak gerekli aletler.

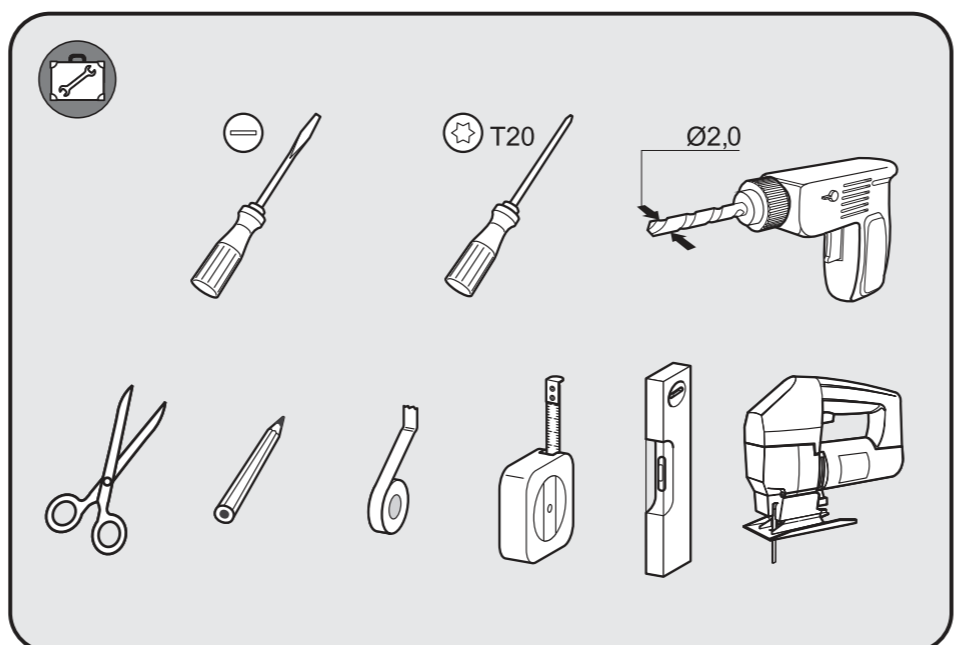

Απαιτούμενα εργαλεία ανάλογα με το μοντέλο.
Potreban alat ovisi o modelu.
Potrebno orodje, odvisno od modela.

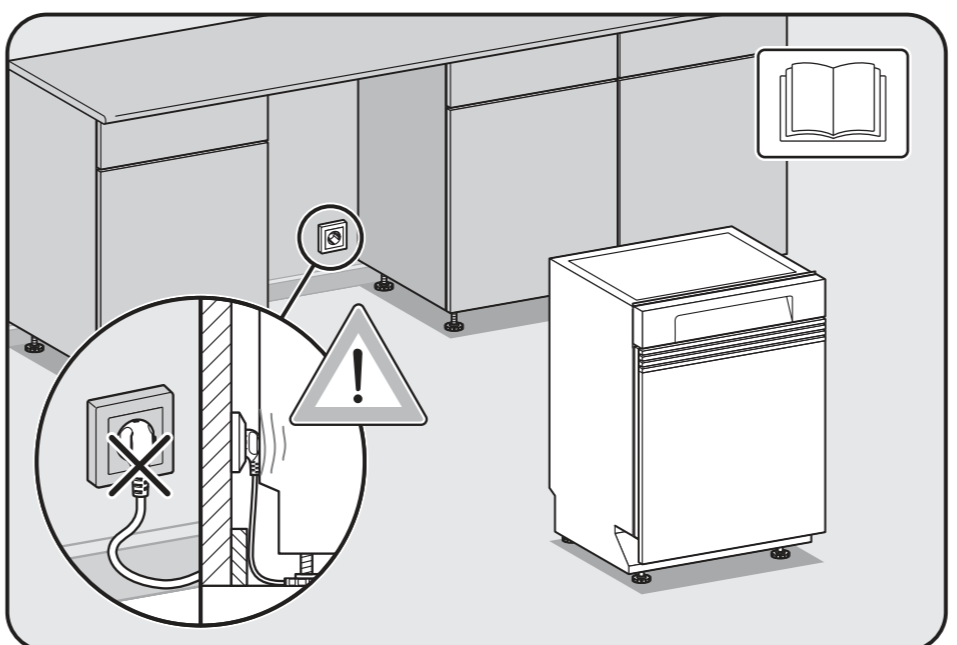

Wasserablauf belüften
Wenn der bauseitige Anschluss für den Wasserablauf tiefer liegt als die Führung für die Rollen des Unterkorbes in der Tür, muss der Wasserablauf belüftet werden.
Venting the water drain
If the on-site drainage connection is situated lower than the guide path for the lower basket rollers in the open door, the drainage system must be vented.
Purger la vidange d'eau
Si le raccord domestique de vidange est placé plus bas que les guides pour les roulettes du panier inférieur dans la porte, la vidange doit être mise à l'air.
Waterafvoer beluchten
Wanneer de waterafvoeraansluiting ter plaatse lager ligt dan de geleiding voor de wieltjes van het onderrek in de deur, moet de waterafvoer worden belucht.

Purgado del desagüe
Será necesario purgar el desagüe si la conexión del mismo estuviere situada a menor altura que la guía de las ruedas del cesto inferior en la puerta.
Ventilar o esgoto da água
Se a ligação para o esgoto da água existente no local se situar num nível mais baixo do que a calha onde o cesto inferior desliza, é necessário efetuar a ventilação do esgoto da água.
Su giderinin havalandırılması
Kurulum yerindeki su gideri bağlantısı, kapaktaki alt sepet tekerlekleri kilavuzundan daha alçaktaysa, su çikşiminin havalandırılması gerekir.
Εξερισμός αποχέτευσης νερού
Αν η σύνδεση για την εκροή του νερού στον χώρο εγκατάστασης βρίσκεται χαμηλότερα από τις πλαϊνές ράγες κύλισης του κάτω καυστρού στην πόρτα, τότε το σύστημα εκροής νερού χρειάζεται εξερισμό.
Prozračivanje odvoda vode
Ako je priključak kućne instalacije za odvod vode dublje postavljen od vodilice za kotačice donje košare u vratima, odvod se mora ventilirati.
Odzračevanje odtoka
Če priključek za odtok leži nižje od vodil za kolesca spodnje košare v vratih, je odtok treba prezračevati.

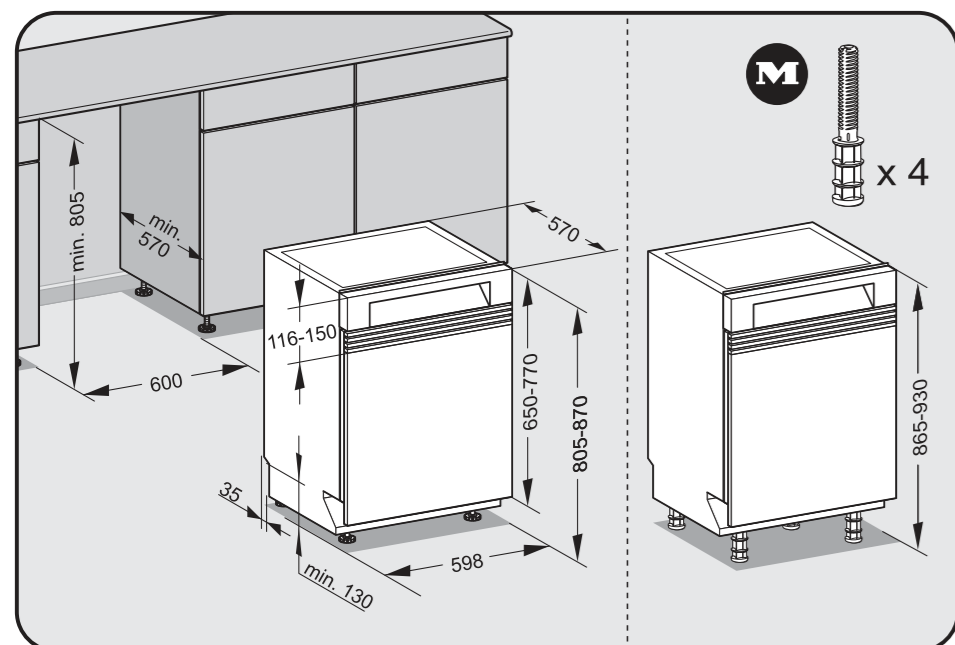

Nachkaufbares Zubehör
Optional accessories
Accessoires en option
Na te bestellen accessoire
Accessorio su richiesta
Accesorio especial

Acessório que pode adquirir
Somradan alinabilen aksesuar
Αγορά πρόσθετου εξοπλισμού
Dodatni pribor
Pribor koji možete naknadno kupiti

