

MANUALE D'USO

GASATORE D'ACQUA

IT

USER MANUAL

SPARKLING WATER MAKER

EN

MANUEL DE L'UTILISATEUR

GAZÉIFICATEUR D'EAU

FR

GEBRAUCHSANLEITUNG

WASSERSPRUDLER

DE

GEBRUIKSAANWIJZING

WATERCARBONATOR

NL

MANUAL DE USO

GASIFICADOR DE AGUA

ES

MANUAL DE USO

GASEIFICADOR DE ÁGUA

PT

BRUKSANVISNING

KOLSYREMASKIN FÖR VATTEN

SV

РУКОВОДСТВО ПО ЭКСПЛУАТАЦИИ

ГАЗОГЕНЕРАТОР ДЛЯ ВОДЫ

RU

BRUGSANVISNING

KULSYREAUTOMAT

DA

INSTRUKCJA OBSŁUGI

SATURATOR WODY

PL

KÄYTTÖOHJE

HIILIHAPOTUSLAITE

FI

BRUKSANVISNING

KULLSYREMASKIN

NO

كتيب الاستخدام

صانعة الماء الغازي

AR

The Smeg logo consists of a stylized cluster of four black circles of varying sizes on the left, followed by the word "smeg" in a bold, lowercase, sans-serif font.

Consigliamo di leggere attentamente questo manuale, che riporta tutte le indicazioni per mantenere inalterate le qualità estetiche e funzionali dell'apparecchio acquistato.

Per ulteriori informazioni sul prodotto: www.smeg.com

We advise you to read this manual carefully, as it contains all the instructions for managing the appliance's aesthetic and functional qualities.

For further information on the product: www.smeg.com

Nous conseillons de lire attentivement ce manuel, qui comprend toutes les indications pour maintenir inaltérées les qualités esthétiques et fonctionnelles de l'appareil acheté.

Pour obtenir des informations supplémentaires sur le produit : www.smeg.com

Wir empfehlen, diese Bedienungsanleitung, die sämtliche Anweisungen enthält, um das Aussehen und die Funktionsfähigkeit des Geräts zu erhalten, sorgfältig zu lesen.

Für weitere Informationen über das Produkt wird auf www.smeg.com verwiesen

We adviseren om deze handleiding aandachtig door te lezen. Ze bevat aanwijzingen die nodig zijn om de esthetische en functionele eigenschappen van het gekochte apparaat intact te houden.

Bezoek voor meer informatie over het product: www.smeg.com

Aconsejamos leer atentamente este manual que contienen todas las indicaciones para mantener inalterada la calidad estética y funcional del aparato adquirido.

Más información sobre el producto en: www.smeg.com

Aconselhamos que leia atentamente este manual, que refere todas as indicações para manter inalteradas as qualidades estéticas e funcionais do aparelho comprado.

Para mais informações sobre o produto: www.smeg.com

Vi rekommenderar att ni noga läser denna handbok som anger alla de nödvändiga anvisningarna för att bibehålla den inköpta apparatens utseende och funktioner.

För mer information om produkten: www.smeg.com

Мы рекомендуем вам внимательно прочитать данное руководство, в котором приводятся все указания, необходимые для поддержания неизменными эстетических и функциональных свойств приобретенного прибора.

Дополнительную информацию об изделии можно получить на сайте: www.smeg.com

Vi anbefaler, at du nøje læser denne vejledning, som indeholder alle anvisninger til at holde det købte apparat i perfekt funktionsmæssig og æstetisk stand.

For yderligere informationer om produktet: www.smeg.com

Zalecamy uważne przeczytanie niniejszej instrukcji, która zawiera wszystkie wskazania dla utrzymania jakości estetyki i funkcjonalności zakupionego urządzenia.

Dalsze informacje dotyczące produktu znajdują się na stronie: www.smeg.com

Lue tämä käyttöopas huolellisesti. Ohjeita noudattamalla taataan laitteen oikeapoppinen ylläpito ja sen ominaisuuksien säilyvyys. Tuotteeseen liittyvät lisätiedot löytyvät osoitteesta www.smeg.com

Vi anbefaler at du leser denne brukerveiledningen grundig, da den inneholder alle indikasjonjer for å bevare de estetiske og funksjonelle kvalitetene til produktet du har kjønt.

For ytterligere informasjon om produktet: www.smeg.com

نصح بقراءة هذا الكتيب بعناية حيث يضم جميع التعليمات التي تضمن الحفاظ على الخصائص الجمالية والوظيفية للمنتج الذي قمت بشرائه.
للمزيد من المعلومات عن المنتج برجاء زيارة www.smeg.com

Model: SKC01

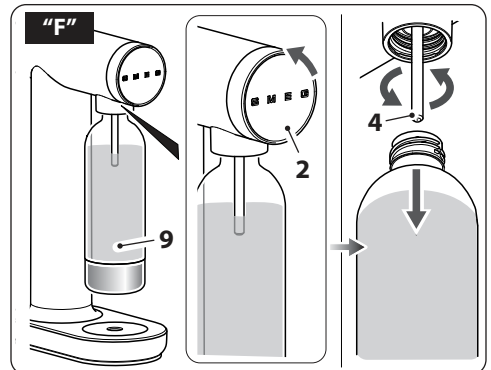
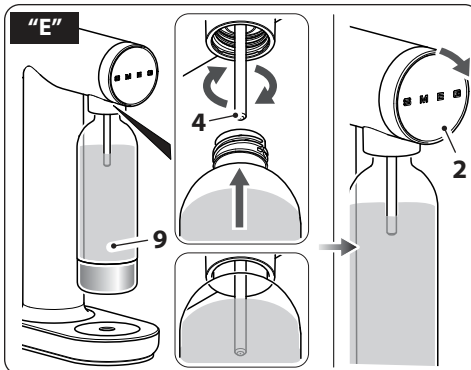
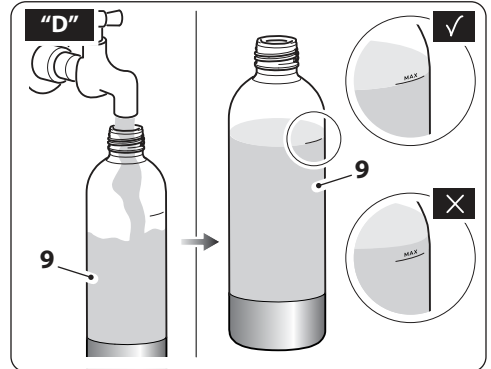
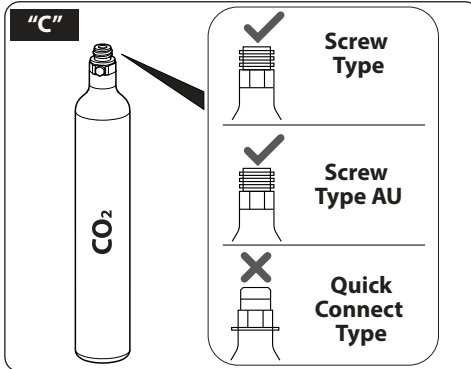
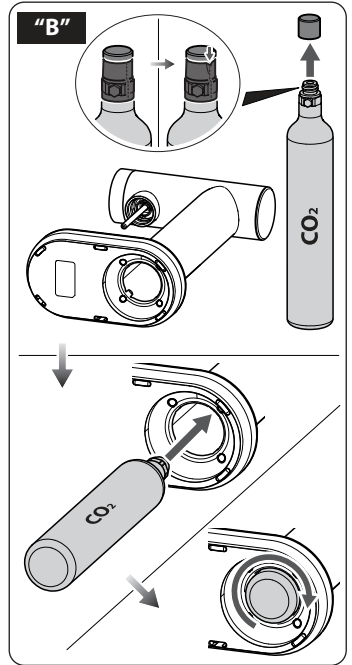
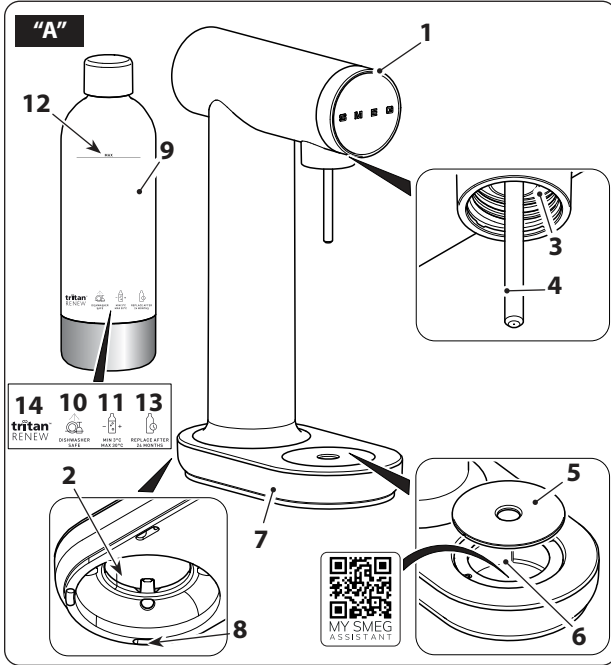



MY SMEG
ASSISTANT

Scansiona il QR code per un accesso rapido al portale My Smeg Assistant
Scan the QR code for a quick access to the portal My Smeg Assistant
Scannez le code QR pour accéder rapidement au portail My Smeg Assistant
Scannen Sie den QR-Code für einen schnellen Zugriff auf das Portal My Smeg Assistant
Scan de QR-code voor snelle toegang tot de portal Mijn Smeg Assistant
Escanee el código QR para acceder rápidamente al portal My Smeg Assistant
Digitalizar o código QR para um acesso rápido ao portal My Smeg Assistant
Skanna QR-koden för snabb åtkomst till portalen My Smeg Assistant
Отсканируйте QR-код для быстрого доступа к portalу My Smeg Assistant
Scan QR-koden for at få hurtig adgang til portalen My Smeg Assistant
Zeskanuj kod QR, aby uzyskać szybki dostęp do portalu My Smeg Assistant
Skannaa QR-koodi, niin pääset nopeasti portaaliin My Smeg Assistant
Skann QR-koden for rask tilgang til portalen My Smeg Assistant

امسح رمز الاستجابة السريعة ضوئيًا للوصول السريع إلى بوابة My Smeg Assistant

Il costruttore si riserva di apportare senza preavviso tutte le modifiche che riterrà utili al miglioramento dei propri prodotti. Le illustrazioni e le descrizioni contenute in questo manuale non sono quindi impegnative ed hanno solo valore indicativo.

The manufacturer reserves the right to make any changes deemed useful for the improvement of its products without prior notice. The illustrations and descriptions contained in this manual are therefore not binding and are merely indicative.

Le fabricant se réserve la faculté d'apporter, sans préavis, toutes les modifications qu'il jugera utiles pour l'amélioration de ses produits. Les illustrations et les descriptions figurant dans ce manuel ne sont pas contraignantes et n'ont qu'une valeur indicative.

Der Hersteller behält sich vor, ohne vorherige Benachrichtigung alle Änderungen vorzunehmen, die er zur Verbesserung seiner Produkte für nützlich erachtet. Die in diesem Handbuch enthaltenen Illustrationen und Beschreibungen sind daher unverbindlich und dienen nur zur Veranschaulichung.

De fabrikant behoudt zich het recht voor zonder waarschuwing alle wijzigingen aan te brengen die hij nodig acht om zijn producten te verbeteren. De afbeeldingen en de beschrijvingen die aanwezig zijn in deze handleiding zijn niet bindend, en hebben enkel een aanduidende waarde.

El fabricante se reserva el derecho a aportar sin aviso previo todas las modificaciones que considere útiles para la mejora de sus propios productos. Las ilustraciones y las descripciones contenidas en este manual no comprometen, por tanto, al fabricante y tienen un valor meramente indicativo.

O fabricante reserva-se o direito de efetuar, sem aviso prévio, qualquer modificação que vise o melhoramento dos respectivos produtos. As ilustrações e descrições contidas neste manual, não são, por isso, vinculativas e possuem apenas valor indicativo.

Tillverkaren förbehåller sig rätten att genomföra alla de ändringar som anses nödvändiga för att förbättra de egna produkterna utan att meddela detta i förväg. De illustrationer och beskrivningar som finns i denna bruksanvisning är vägledande och därmed inte bindande.

Производитель оставляет за собой право вносить без предупреждения все изменения, которые посчитает полезными для улучшения собственной продукции. Рисунки и описания, содержащиеся в данном Руководстве по эксплуатации, не имеют обязательств и имеют ознакомительный характер.

Producenten forbeholder sig retten til at foretage eventuelle ændringer, der anses for at være en forbedring af det oprindelige produkt, uden forudgående varsel. Illustrationer og beskrivelser i denne betjeningsvejledning er derfor ikke bindende og kun vejledende.

Producent zastrzega sobie prawo do nanoszenia, bez uprzedniego powiadomienia, wszelkich zmian, które uzna za przydatne w celu ulepszenia swoich produktów. Rysunki i opisy zawarte w niniejszej instrukcji nie są zobowiązujące i mają charakter poglądowy.

Valmistaja pidättää itsellään oikeuden tehdä ohjeisiin mielestään tarpeellisia muutoksia ilman ennakkoilmoitusta. Tässä oppaassa olevat kuvat ja piirroksot eivät näin ollen ole sitovia, vaan ne annetaan vain viitteellisessä mielessä.

Produsenten forbeholder seg rett til endringer på sine produkter grunnet tekniske fremskritt, uten forutgående varsel. Illustrasjonene og beskrivelsene i denne bruksanvisningen er derfor ikke bindende og skal kun betraktes som retningsgivende.

“تحفظ جهة التصنيع لنفسها بالحق في القيام بجميع التعديلات التي تراها مناسبة لتحسين منتجاتها دون إخطار مسبق. ولذلك، لا تعتبر الرسوم التوضيحية والأوصاف الواردة في هذا الدليل ملزمة وإنما ذات قيمة إرشادية فقط”

Informazioni importanti per l'utente / Important information for the user
Informations importantes pour l'utilisateur / Wichtige Informationen für den Benutzer
Belangrijke informatie voor de gebruiker / Información importante para el usuario
Informações importantes para o utilizador / Viktig information til brugænderen
Важная информация для пользователя / Viktig information til brukeren
Ważne informacje dla użytkownika / Tärkeitä tietoja käyttäjälle
Viktig informasjon for brukere / معلومات هامة للمستخدم

⚠ Avvertenze / Instructions / Avertissements / Hinweise / Waarschuwingen / Advertencias / Advertências / Varningar / Меры предосторожности / Advarsler / Ostrzeżenia / Varoitukset / Advarsler / تحذيرات

Informazioni generali su questo manuale d'uso, di sicurezza e per lo smaltimento finale / General information on this user manual, on safety and final disposal / Informations générales sur ce manuel d'utilisation, sur la sécurité et sur l'élimination définitive de l'appareil / Allgemeine Informationen zu dieser Gebrauchsanleitung, zur Sicherheit und die endgültige Entsorgung / Algemene informatie over deze handleiding, veiligheidsinstructies en uiteindelijke verwerking / Información general del manual relativa al uso, la seguridad y la eliminación final / Informações gerais sobre este manual do utilizador, segurança e para a eliminação final / Allmän information om denna bruksanvisning, om säkerhet och för slutligt bortskaffande / Общая информация о данном руководстве по эксплуатации, безопасности и окончательной утилизации / Generelle oplysninger om denne betjenings- og sikkerhedsvejledning samt endelig bortskaffelse / Ogólne informacje dotyczące użytkowania, bezpieczeństwa i użycyacji / Käyttöohjetta, turvallisuutta ja käytöstä poistoa koskevat yleisiedot / Generell informasjon om denne brukerveiledningen, sikkerhet og endelig kassering av produktet / معلومات عامة عن دليل استخدام هذا الجهاز وسلامته / استخدامه وكيفية التخلص عن الجهاز بشكل نهائي

📖 Descrizione / Description / Description / Beschreibung / Beschrijving / Descripción / Descrição / Beskrivning / Описание / Beskrivelse / Opis / Kuvaus / Beskrivelse / الوصف

Descrizione dell'apparecchio / Appliance description / Description de l'appareil / Beschreibung des Geräts / Omschrijving van het apparaat / Descripción del aparato / Descrição do aparelho / Beskrivning av apparaten / Описание прибора / Beskrivelse af apparatet / Opis urządzenia / Laitteen kuvaus / Beskrivelse av apparatet / وصف الجهاز

👉 Uso / Use / Utilisation / Gebrauch / Gebruik / Uso / Utilização / Användning / Использование / Anvendelse / Użytkowanie / Käyttö / Bruk / الإستعمال

Informazioni sull'uso dell'apparecchio / Information on using your appliance / Informations sur l'utilisation de l'appareil / Informationen zum Gebrauch des Geräts / Informatie over het gebruik van het apparaat / Información sobre el uso del aparato / Informações sobre a utilização do aparelho / Information om användning av apparaten / Информация об использовании прибора / Oplysninger om brug af apparatet / Informacje dotyczące użytkowania urządzenia / Laitteistoa koskevat käyttöohjeet / Informasjon om bruken av apparatet / معلومات عن استخدام الجهاز

🧹 Pulizia e manutenzione / Cleaning and care / Nettoyage et entretien / Reinigung und Wartung / Reiniging en onderhoud / Limpieza y mantenimiento / Limpeza e manutenção / Rengöring och underhåll / Чистка и техническое обслуживание / Rengøring og vedligeholdelse / Czystczenie i konserwacja / Puhdistus ja hoito / Rengjøring og vedlikehold / التنظيف والصيانة

Informazioni per la corretta pulizia e manutenzione dell'apparecchio / Information for proper cleaning and maintenance of the appliance / Informations pour un nettoyage et un entretien corrects de l'appareil / Informationen zur ordnungsgemäßen Reinigung und Wartung des Geräts / Informatie voor de juiste wijze van reiniging en onderhoud van het apparaat / Información sobre la limpieza y el mantenimiento correctos del aparato / Informações para a limpeza e manutenção corretas do aparelho / Information för korrekt rengöring och underhåll av apparaten / Информация по корректной очистке и техобслуживанию прибора / Oplysninger om korrekt rengøring og vedligeholdelse af apparatet / Informacje dotyczące prawidłowego czyszczenia i konserwacji urządzenia / Laitteiston oikeaa puhdistusta ja huoltoa koskevat tiedot / Informasjon for korrekt rengjøring og vedlikehold av apparatet / معلومات لتنظيف وصيانة الجهاز بشكل صحيح

⚠ Avvertenza di sicurezza / Safety instructions / Consignes de sécurité / Sicherheitshinweise / Veiligheidswaarschuwingen / Advertencia de seguridad / Advertências de segurança / Säkerhetsvarning / Предупреждение о безопасности / Sikkerhedsanvisninger / Ostrzeżenia dotyczące bezpieczeństwa / Turvallisuuteen liittyvät varoitukset / Sikkerhetsadvarsler / تحذير السلامة

📄 Informazione / Information / Information / Information / Information / Informatie / Información / Informação / Information / Информация / Information / Informacja / Tietoja / Informasjon / معلومات

📝 Suggerimento / Advice / Conseil / Empfehlungen / Aanbeveling / Sugerencia / Sugestões / Råd / Рекомендация / Forslag / Porada / Neuvo / Forslag / اقتراحات



1 WARNINGS

This user manual is an integral part of the appliance and must therefore be kept in its entirety and on-hand for the whole working life of the appliance.

1.1 Intended use

Failure to comply with the safety recommendations and not reading the instruction manual can lead to improper use of the appliance by the users and consequent personal injury.

- Use the appliance indoors only.
- This appliance and its accessories are intended for use in the home and similar environments, such as:
 - in the kitchen area for the staff of shops, offices and other work environments;
 - in bed and breakfast and agritourism accommodation;
 - by guests at hotels and motels, and in residential environments.
- Other uses, in restaurants, bars and cafés for example, are improper.
- Do not use the appliance for purposes different to those for which it is intended.
- Only gasify plain water. Never fill the bottle with anything other than drinking water.
- Keep the water gasifier out of the reach of children.
- This appliance may not be used by people of reduced physical, sensory or mental capacity, or without sufficient experience and knowledge (including children under the age of 12), unless they are supervised or instructed by adults who are responsible

for their safety.

- Children must not be allowed to play with the machine.

1.2 General safety warnings

Follow all safety instructions for safe use of the appliance:

- Read this user manual carefully before using the appliance.
- Always use the water gasifier vertically.
- Do not move the water gasifier when gasifying.
- Keep the appliance and CO₂ cylinder away from heat or steam.
- Do not position the appliance above or near gas or electric hob burners or inside an oven. Keep away from direct sunlight.
- Do not immerse the appliance or CO₂ cylinder in water or any other liquid.
- Do not wash the appliance in the dishwasher.
- Do not use the appliance when it has fallen on the floor or is damaged in any way whatsoever. In the event of a fault, have the appliance repaired only by a qualified technician or by an authorised after-sales service.



Warnings

1.3 Safety recommendations for this appliance

- Do not move the water gasifier with the gas cylinder attached. Always unscrew the cartridge before transport or travel to avoid damaging the internal parts.
- Only use gas cylinders approved for this gasifier. Other cartridges may compromise the operation of the appliance or pose a safety risk.
- Never rotate the gasification knob to release CO₂ without having first inserted a full bottle.
- Never gasify an empty bottle. It is highly dangerous. Always fill with water up to the filling line.
- Before gasifying water, make sure that the gas cylinder has been properly secured in the compartment. It may loosen over time, making its action less effective.
- Fill the bottle with water up to the filling line. If it is filled beyond the indicated filling line, water flows through the appliance and ends up in the collection tray. This is not dangerous or harmful to the appliance.
- Do not remove the bottle during carbonation.
- Do not add sliced fruit, ice and flavourings in the bottle with the water to be gasified. Add AFTER gasification.
- Stop gasification when the sound emitted by the overpressure valve is heard.
- Do not freeze the bottle.
- Always keep the bottle clean to avoid bacteria and bad odours.
- Never use a deformed, discoloured or scratched bottle. Replace damaged or

deformed bottles with new ones.

- Using other bottles may compromise the operation of the appliance or pose a safety risk.
- The instructions for correct cleaning of the appliance are given in the "Cleaning and Maintenance" paragraph.



Max permitted operating pressure:

1.0Mpa

Max permitted operating

temperature: 30°C

1.4 CO₂ cylinder safety

To reduce the risk of CO₂ leaks, personal injury and property damages:

- Do not move the gas cylinder when it is screwed onto the water gasifier. When moving, keep the cylinder and appliance separate.
- Do not place the gas cylinder near heat sources. Cylinder pressure depends on room temperature, so it is good to keep it away from hot plates, radiators, direct sunlight, etc.
- The gas cylinder should only be used at room temperature. After transportation and frequent use, the cylinder may become cold and less effective. Avoid touching it if it is covered with ice.
- Do not expose the CO₂ cylinder to temperatures over 50°C / 120°F. Keep it away from sunlight and store in a ventilated area.
- In the event of CO₂ leaks, ventilate the area, breathe fresh air and, in case of malaise, seek medical attention immediately.

Warnings



- Do not insert the CO₂ cylinder in its compartment when the appliance is running.
- Do not remove the CO₂ cylinder when the appliance is running.
- Do not handle or remove the CO₂ cylinder when it is releasing CO₂.
- Keep the gas cylinder out of the reach of children.
- The design or shape of the gas cylinder cannot be manipulated or changed in any other way.
- If the gas cylinder breaks or is damaged, it cannot be used with the water gasifier. Contact your dealer for replacement.

1.5 Manufacturer's liability

The manufacturer declines all liability for injury/damage undergone by persons and objects due to:

- failure to comply with safety warnings.
- use of the appliance different from that envisioned;
- the user manual not being read;
- tampering with individual parts of the appliance;
- damages caused by using non Smeg bottles;
- damages caused by the use of non compliant or defective CO₂ cylinders;
- use of non-original spare parts;



Keep these instructions carefully. Whenever the appliance is transferred to other persons, it must be accompanied by these user instructions.

These instructions can be downloaded from the Smeg website www.smeg.com or from the My Smeg Assistant App by scanning the QR inside the drip tray.

DISPOSAL



This appliance must be disposed of separately from other waste (Directive 2012/19/EU).

- This appliance does not contain substances in quantities such to be considered hazardous to health and the environment, pursuant to current European Directives.
- For the disposal of the water gasifier and Smeg bottles, the applicable national and international legislation establishes that the machine must be disposed of through a municipal recycling plant. (cit. Philips)
- Take packing materials at an appropriate recycling facility. To help protect the environment, please dispose of the product properly at the end of its useful life and do not treat it as household waste. Please contact your local authorities for more information about recycling centres and opening hours.





Description/Use

2 APPLIANCE DESCRIPTION (Fig. A)

- 1 Control knob.
- 2 Gas cylinder compartment.
- 3 Water bottle compartment.
- 4 Nozzle.
- 5 Drip tray cover.
- 6 Drip tray.
- 7 Base.
- 8 Non-slip feet.
- 9 Bottle with cap and steel bottom

2.1 Bottle icons

Icon	Meaning
 (10)	The bottle is dishwasher safe.
 (11)	The bottle filled with carbonated water can withstand temperatures ranging from a minimum of 3°C / 35°F to a maximum of 30°C / 85°F. Do not expose the bottle to temperatures other than the indicated range.
MAX (12)	Fill the bottle to the filling mark. Otherwise, the excess water that comes out of the machine during the carbonation process ends up in the drip tray.
 (13)	It is recommended to replace the bottle with a new one after 24 months of first use.
tritan™ RENEW (14)	The bottle body is made of special Tritan™ Renew plastic, with 50% recycled material.

3 USE

3.1 Gas cylinder purchases and compatibility (Fig. C)

The Smeg Sparkling Water Maker is compatible with 400-425g/60L- 80L (14.5 oz CO₂/60L) screw type cylinders from Philips, Aarke and Sodastream (except for the QuickConnect coupling), and many other standard screw type gas cylinders approved for use with sparkling water producers.

CO₂ gas cylinder are readily available at major hypermarkets, electrical retailers or e-commerce websites.

If you purchase the Smeg Sparkling Water Maker in Australia or New Zealand, it will be compatible with Australian and New Zealand CO₂ gas cylinders available at major hypermarkets, electrical retailers or e-commerce websites.



Other gas cylinders may seem suitable, but they could damage the machine or cause safety hazards.



We recommend keeping a spare CO₂ cylinder at home to use as soon as gas runs out.



3.2 Before commissioning

- Unpack the appliance carefully and remove all packaging materials.
- Clean the body with a damp cloth to remove any dust.
- Hand wash the bottle with hot water and dish washing liquid. Rinse and dry the exterior thoroughly with a soft cloth.

3.3 Gas cylinder assembly and replacement (Fig. B)

- Carefully place the gasifier horizontally on one side, making sure to place it on a flat and stable surface.
- Remove the CO₂ cylinder seal and cap.
- Insert the cylinder through the hole in the bottom, without letting it fall.
- When you feel that the cylinder has reached the bottom, start screwing it clockwise until it is fully tightened, taking care not to tighten it too much.
- When empty, replace the cylinder in the same way as it was installed the first time, thus unscrew it counter-clockwise and carefully remove it from the compartment.

3.4 Carbonation process (Fig. D-E-F)



NEVER gasify substances other than pure water:

- do not add pieces of fruit, vegetables or herbs in the bottle before gasification;
- do not add sugary drinks or those with other additives before gasification; the use of these substances could cause the pressure relief valve to be blocked and therefore make gasifier use dangerous;
- do not gasify wine, carbonated beverages, juices or milk;
- do not add ice before gasification;
- do not attempt to re-gasify sparkling water.

- Make sure you have inserted the gas cylinder in the appropriate compartment (2).
- Place the gasifier on a flat and stable surface.
- Fill the bottle (9) with cold, clean water to the maximum level indicated (800 ml).
- Screw the bottle (9) with water in its housing (3) by turning it clockwise until it is fully tightened. Make sure that it is positioned straight and that the nozzle (4) is immersed in water.
- Turn the knob (1) clockwise to dispense gas.



Use

- Turn the knob counter-clockwise to stop gasification. The remaining pressure in the bottle is automatically released with a murmur-like sound. Finally, unscrew the bottle (9).



Water in the bottle starts to rise when CO₂ is released. For this reason it is important to fill the bottle to the maximum filling level indicated, so that water does not enter the cylinder compartment and does not leave the safety valves.

Although it is not dangerous or harmful to the product, exceeding the maximum level causes the water to pass through the safety valves and the excess water ends up in the drip tray.

Carbonation levels

With the Smeg Sparkling Water Maker Sparkling Water Maker you can manually adjust the desired amount of bubbles using the knob. It is important to remember that the absorption of carbon dioxide by water depends on a few factors:

- If the water is too hot, it is more difficult for CO₂ to bind with water. For best results, it is recommended to use refrigerator water (5°C).
- As CO₂ runs out, less CO₂ is gradually added to water. The results therefore vary with a new or almost new cartridge.

Therefore, to obtain a good amount of CO₂ in water, we recommend keeping the knob turned for 2-3 seconds or repeating this action several times.

For the opposite results, to obtain a less sparkling water, run the carbonation process only once or turn the knob only halfway.



When a hiss is heard, it means that the overpressure safety valve has tripped. Release the knob and return it to the starting position.

3.5 Addition of concentrates

It is possible to add an aroma to sparkling water using concentrates, juices and syrups of the brands specially developed for use with gasifiers and available in major supermarkets and department stores.

It is possible to add the flavoured syrup directly into the bottle only and exclusively after the carbonation process.

After consuming the sugar water, always wash the bottle thoroughly so that the sugar is not dispersed in the appliance the next time you use it.



4 CLEANING AND MAINTENANCE



Incorrect use. Risk of damage to the surfaces.

- Do not use steam jets to clean the appliance.
- Never wash the product in the dishwasher.
- Do not use abrasive or corrosive detergents (e.g. powder products, stain removers and metallic scourers).
- Do not use rough or abrasive materials or sharp metal scrapers.

4.1 Body cleaning

For good product preservation, wipe the surfaces regularly with a damp cloth and dry with a soft cloth.

4.1 Bottle cleaning

Clean the inside of the bottle before and after each use to remove any residue, such as added flavourings. The bottle can be washed by hand with the help of a brush with soft bristles or in a dishwasher. At the end of the cleaning, store the empty bottle without a cap to avoid moisture inside.

What To Do If.....

Problem	Possible causes	Solution
When you turn the knob clockwise, the gas is not released or too little is released.	CO ₂ cylinder empty.	Check whether the CO ₂ cylinder is empty.
	CO ₂ cylinder incorrectly screwed in.	Try to screw in the CO ₂ cylinder more securely and try again.
	Leak	If you hear a machine leak noise when turning the knob clockwise, refer to the third problem listed below.
When you turn the knob clockwise, the gas flows into the bottle, but the water does not receive carbon dioxide.	Incomplete knob rotation.	Be sure to keep the knob turned clockwise until the valve buzzes. Now let go. Do not let go until you hear CO ₂ being released.
There is a leaking noise when you turn the knob clockwise and very little gas flows into the bottle with the water.	CO ₂ cylinder incorrectly screwed in.	Try to screw in the CO ₂ cylinder more securely and try again.
	Problem with the CO ₂ cylinder gasket.	Contact the technical after-sales Service for its replacement.
There are drops of water in the cylinder compartment.	CO ₂ cylinder incorrectly screwed in.	Try to screw in the CO ₂ cylinder more securely and try again.
	Problem with the CO ₂ cylinder gasket.	Contact the technical after-sales Service for its replacement.
The gas begins to expand when you screw the cylinder into the machine, even if you do not turn the knob to the left.	Cylinder gasket problem.	Contact the technical after-sales Service for its replacement.
The cylinder freezes in the machine when it is used.	Possible leakage between cylinder and machine	Try to screw in the cylinder more securely and try again
	Cylinder gasket problem.	Contact the technical after-sales Service for its replacement.
 Contact local technical support if the problem is not solved or in case of other types of faults.		