



72046

GAME BOY™



Booklet available in English
Heft in deutscher Sprache erhältlich
Livret disponible en français
Libretto disponibile in italiano
Folleto disponible en español
如需中文版手册

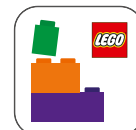

LEGO® Builder

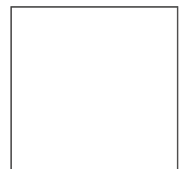



LEGO.com/sustainable-packaging



FR

DONNEZ
OU
RECYCLEZ



ASSOCIATION

OU



MAGASIN

OU



DÉCHÈTERIE

Adresses sur quefairedemesdechets.fr



BUiLDER



Apple and the Apple logo are trademarks of Apple Inc., registered in the U.S. and other countries and regions. App Store is a service mark of Apple Inc. Google Play and the Google Play logo are trademarks of Google LLC. Tencent and the Tencent logo are trademarks of Tencent Inc.

Q LEGO.com/devicecheck



Q LEGO® Builder

THANK YOU FOR SELECTING THE LEGO® GAME BOY™

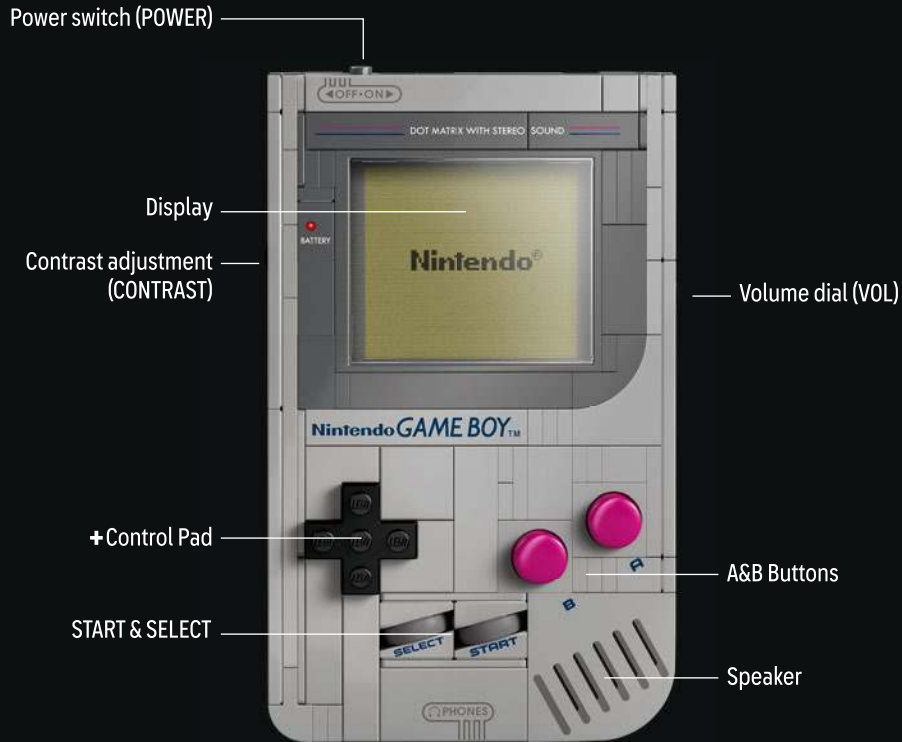

CAUTION! Clicking the power switch may result in acute feelings of nostalgia.

INSERT TO CONTINUE



This authentic LEGO® Game Boy™ has been constructed using the finest materials to appeal to you, the discerning retro gamer. For the full 1989 experience, insert the Game Pak cartridge and realistic Lenticular Screen and ignore repeated calls to come downstairs for your dinner.



BASIC SET INCLUDES:

- 421 PIECES
- TWO GAME PAK CARTRIDGES
- THREE LENTICULAR SCREENS
- ZERO BATTERIES (DON'T NEED 'EM!)



HAND-HELD HISTORY

Upon its launch in Japan in 1989, the original Game Boy™ was considered a revolution in video gaming. The powerful, portable console allowed video-game fans to enjoy their favourite games on the go, with a battery life that lasted up to a whole day. Our designers, very much fans themselves, have lovingly recreated its iconic form, so that you can own an authentic piece of hand-held history. Batteries not included.

UNCOVER AN ICON

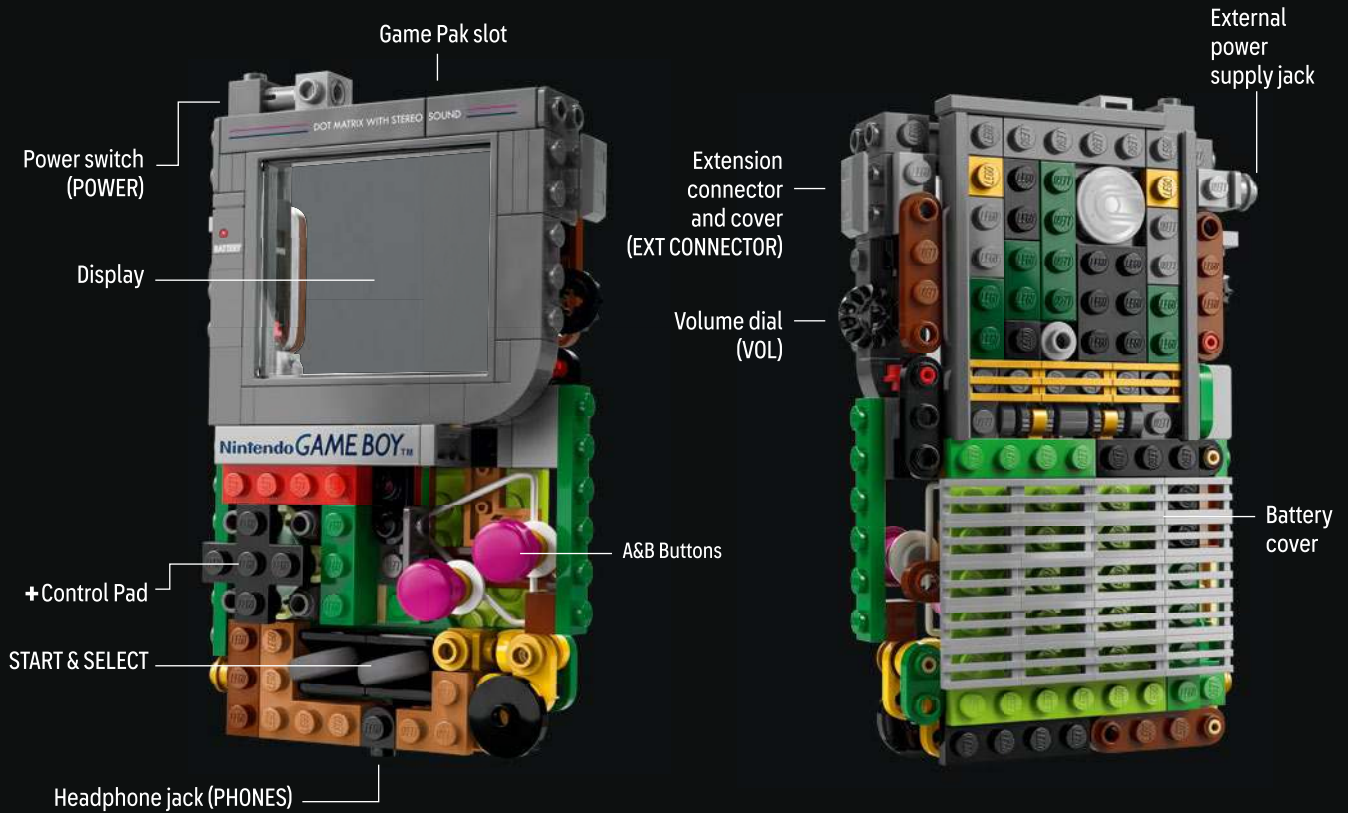

IT'S WHAT'S INSIDE THAT COUNTS:

Sure, the iconic casing might be the star of the show, but we showed just as much love to the interior of both the LEGO® Game Boy™ and Game Pak, obsessing over detail and colour for that authentic feel.

"I love watching people use the power switch, when they feel that snap, it always takes them back to that Game Boy realm!"

LEGO® Game Boy™
Lead Designer Carl Merriam



SUPER MARIO LAND™

ONE GIANT LEAP

With appearances in numerous NES, arcade and Game & Watch titles, Mario was no stranger to the world when he jumped onto the Game Boy™ for the first time in *Super Mario Land™*. Launched alongside the Game Boy's release in 1989, the game sees Mario explore a whole new world, called Sarasaland, as he attempts to rescue Princess Daisy in her debut appearance. The responsibility to translate the much-loved, platform-based gameplay from the more powerful NES to the small screen fell to the same team developing the Game Boy itself, giving them precious insights into the console's potential. They couldn't have fared better – critics and fans alike agreed that it was a giant leap forwards for a handheld title, with 12 expertly plotted levels packed with original enemies and a devilish expert mode for seasoned gamers. It's still considered a classic.

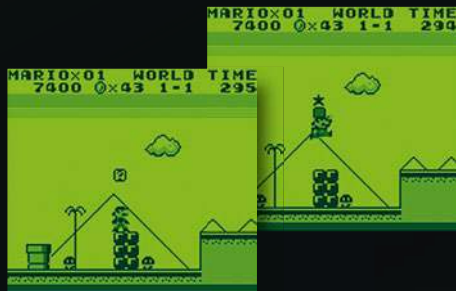

ICONIC: Game Pak and in-game screens from the original *Super Mario Land*[™].



SMALL SCREEN. BIG ADVENTURE.

Released in 1993, four years after the Game Boy's launch, *Link's Awakening* was the small-screen debut for the already-popular *Zelda* franchise. Adored by fans for its emotionally driven, story-based gameplay, with wonderfully creative puzzles and challenges, this was the first *Zelda* title to be set outside of the kingdom of Hyrule, and the first not to feature Princess Zelda. In *Link's Awakening*, the titular character is stranded on an island. His only chance of escape is to awaken the mythical Windfish by collecting magical musical instruments. Its place in the hearts and minds of gamers of all ages, all over the world, remains to this day.

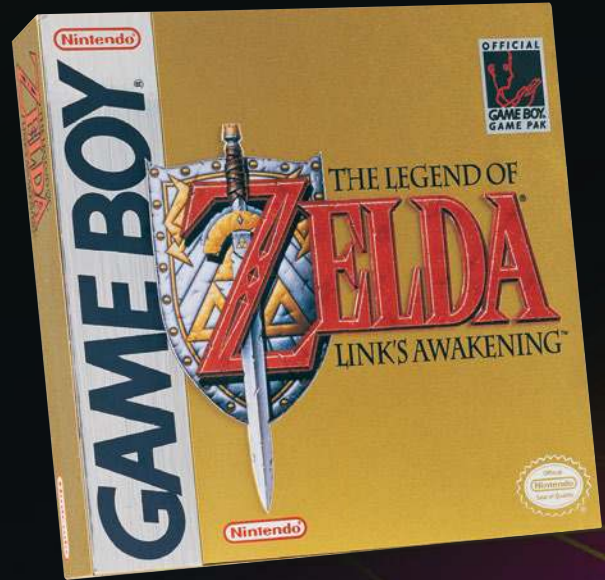

LEGENDARY: Original in-game screens from *Link's Awakening*.



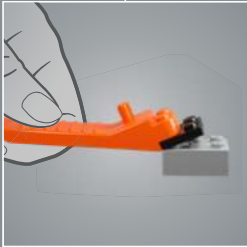
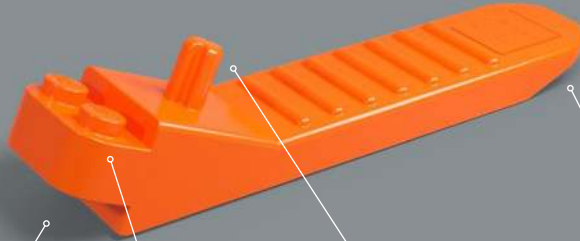

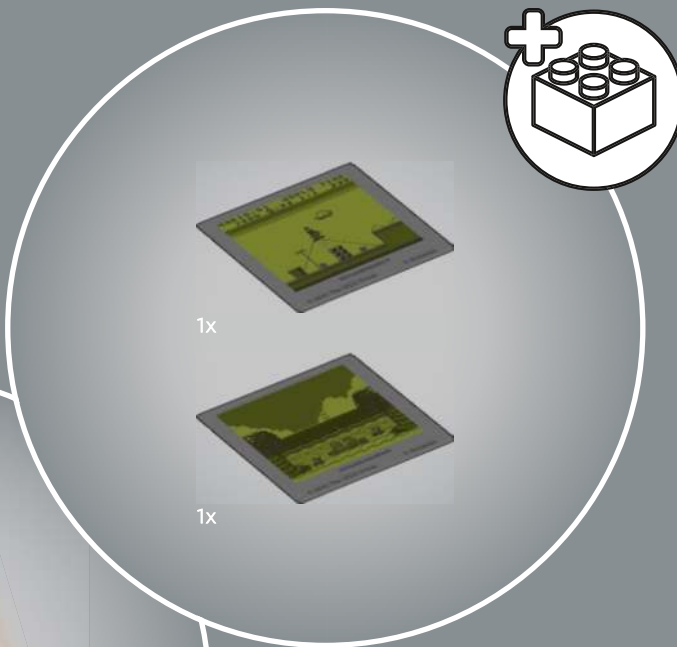

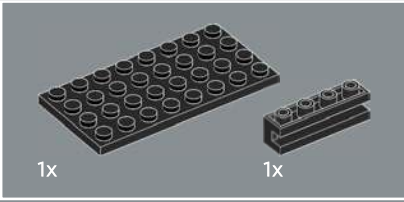

1

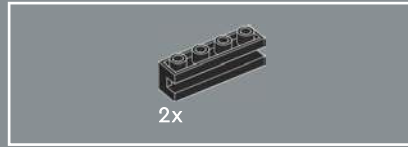
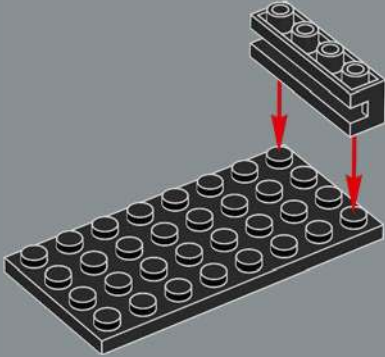

2

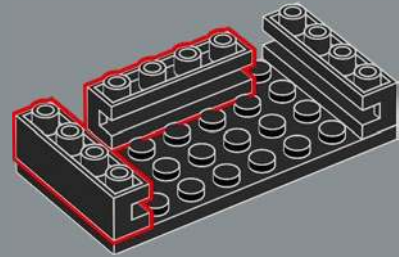

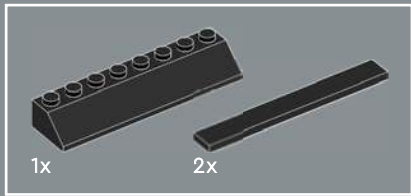

3

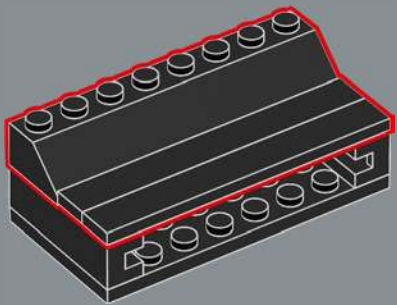

4

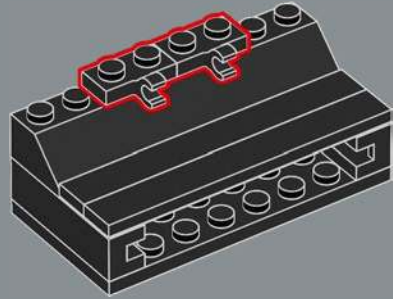

5

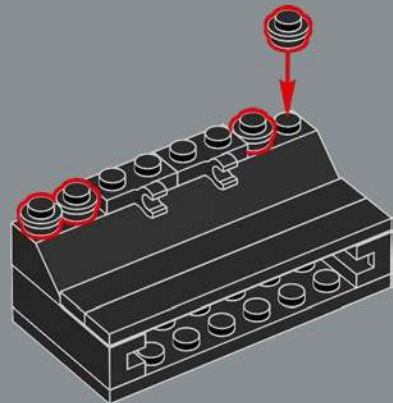



6

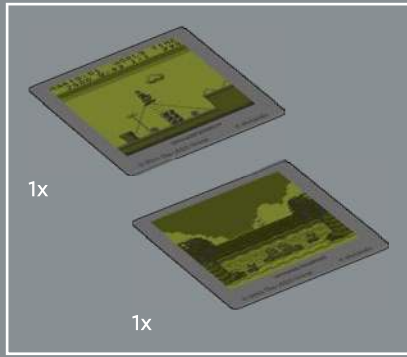
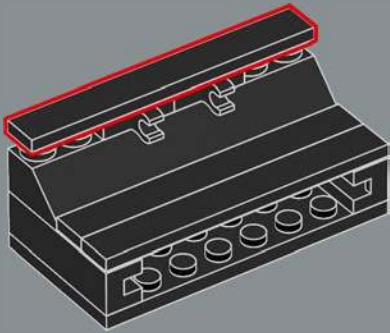

7

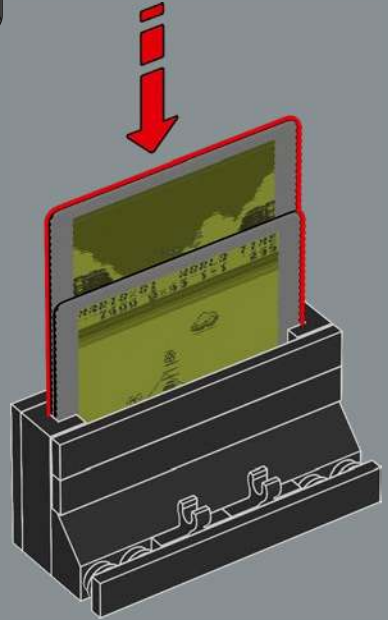

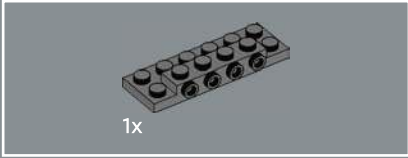

1

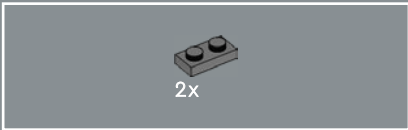
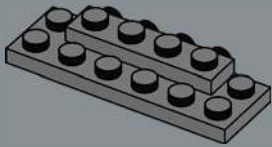

2

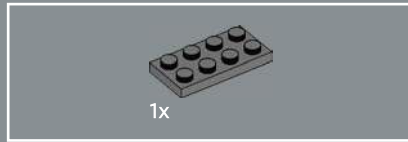
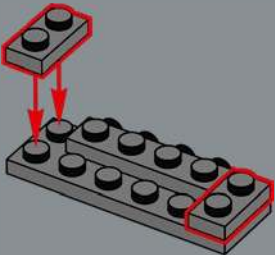

3

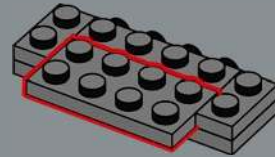

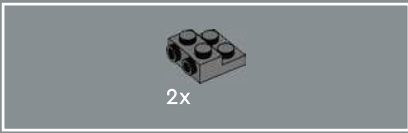

4

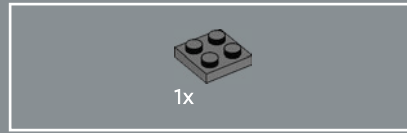
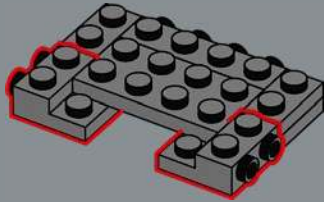

5

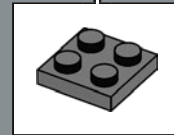
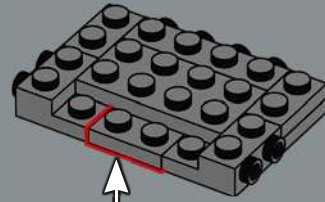

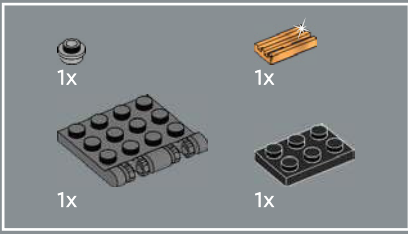

6

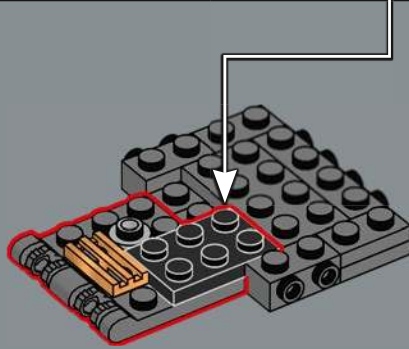
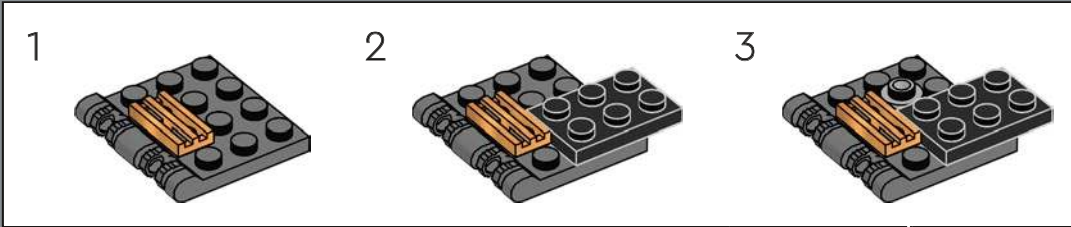



7

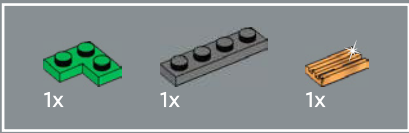
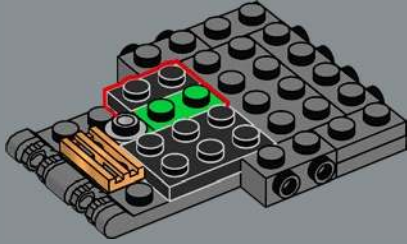

8

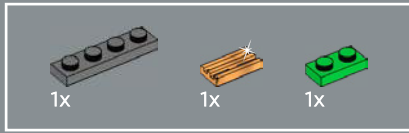
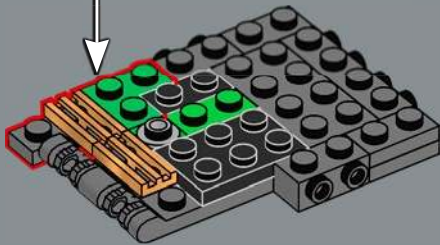
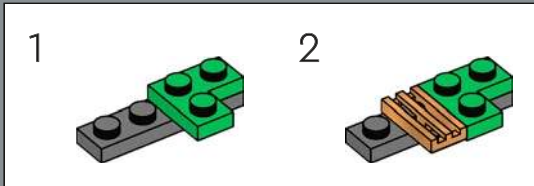

9

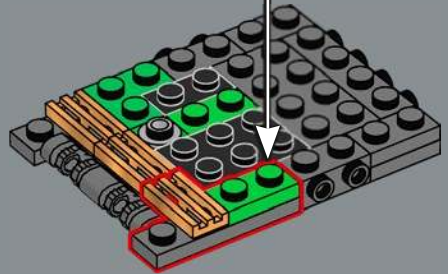
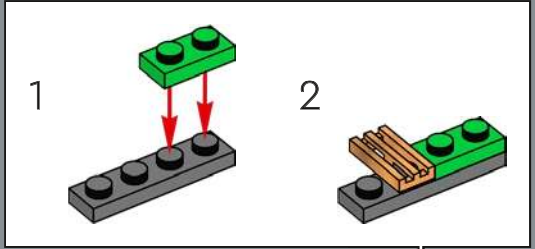

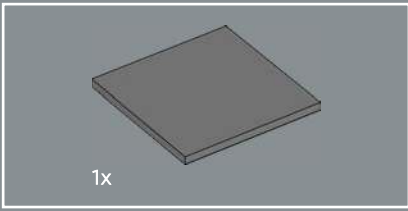

10

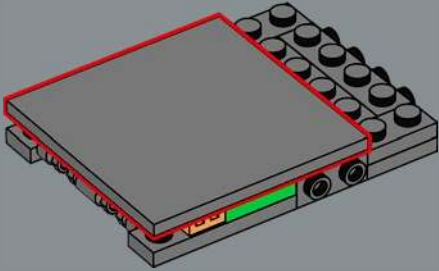

11

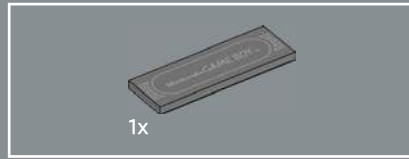

12



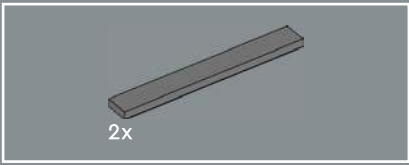

13

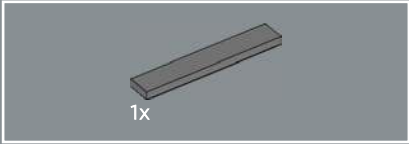

14



15

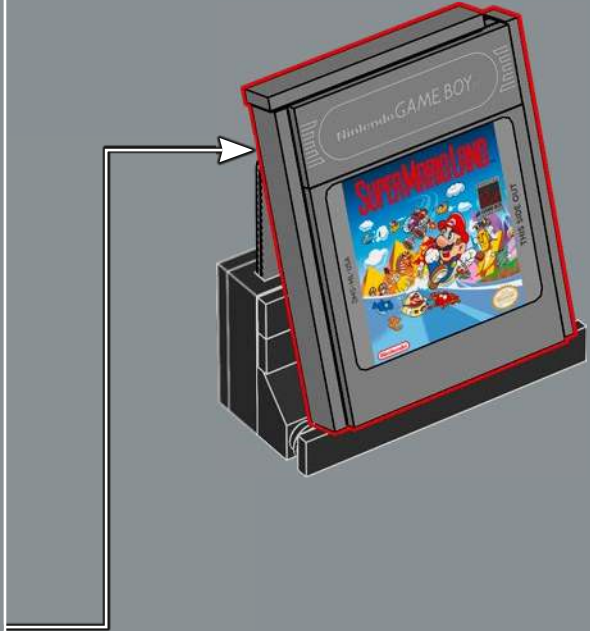



1x



1x

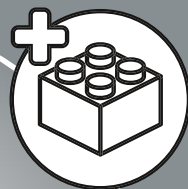

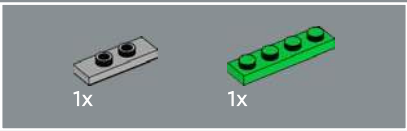

1

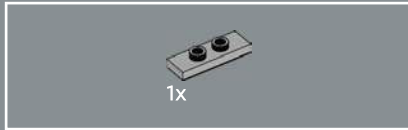
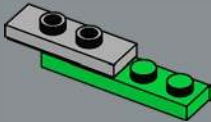

2

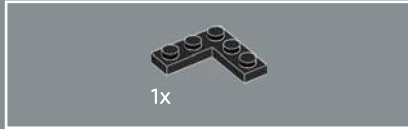
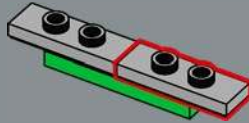

3

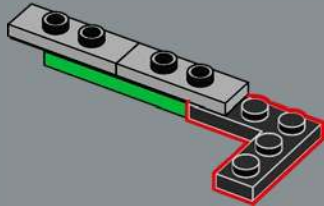

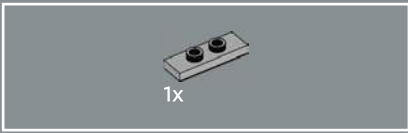

4

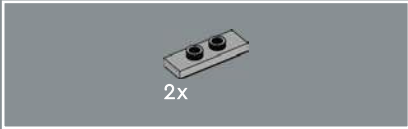
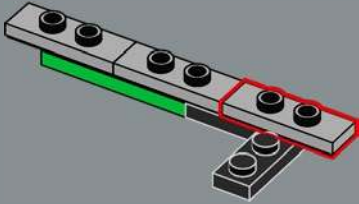

5

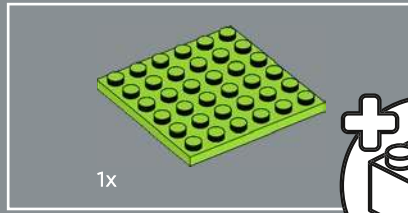
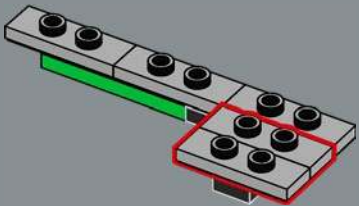

6

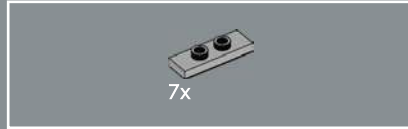
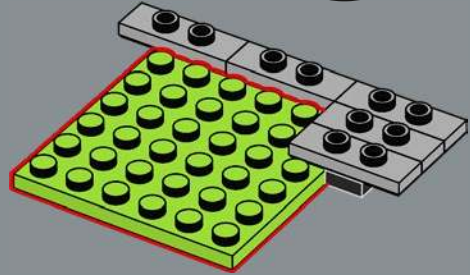

7

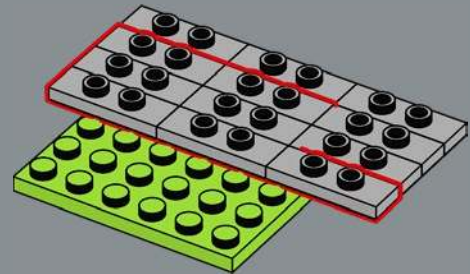

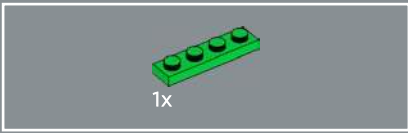

8

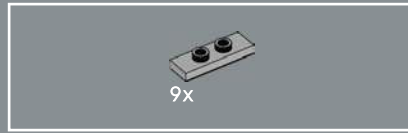
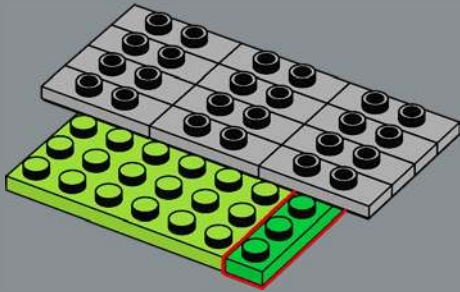

9

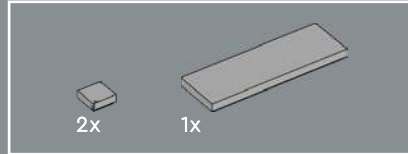
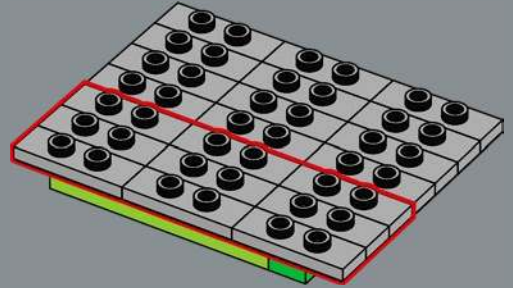

10

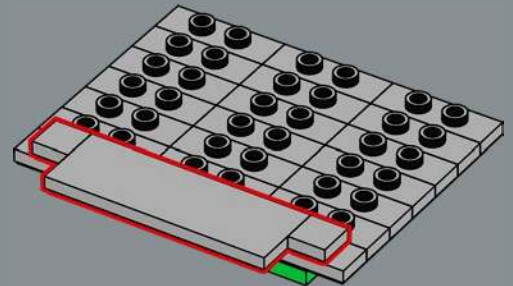

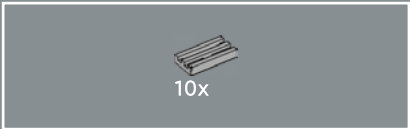

11

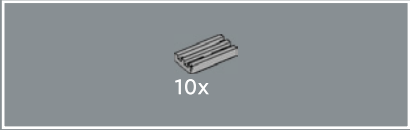
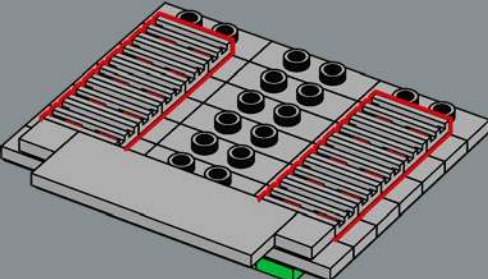

12

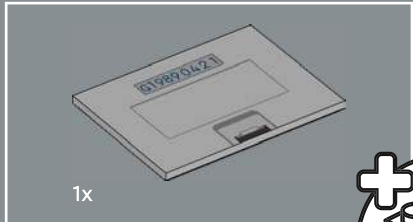
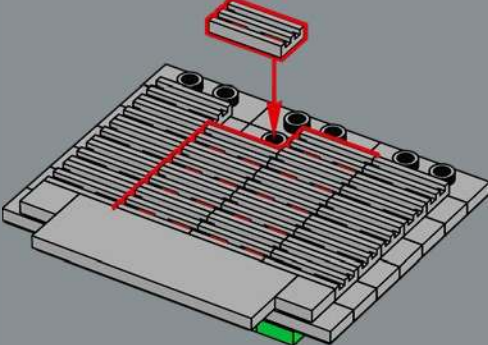

13

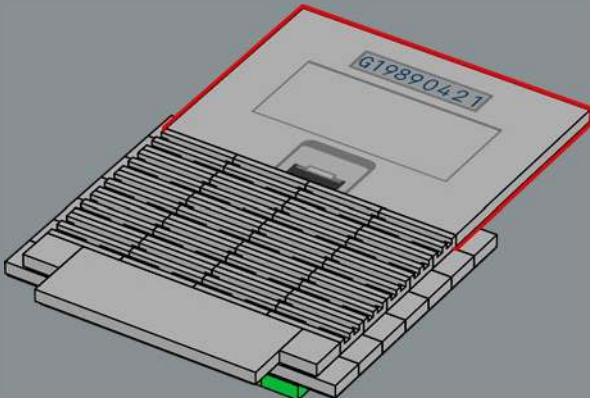
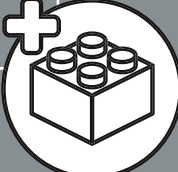

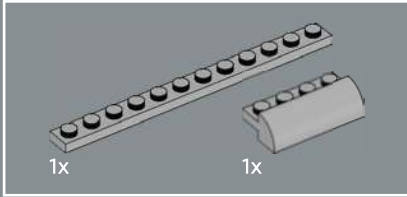
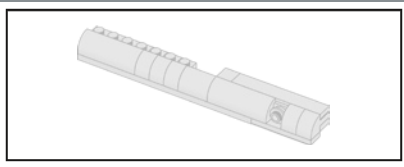

14

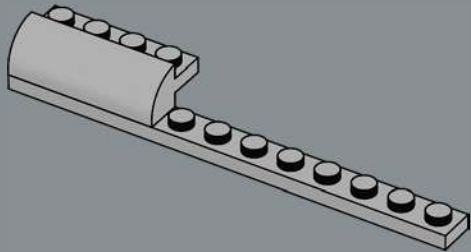

15

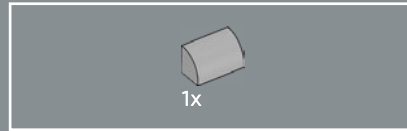
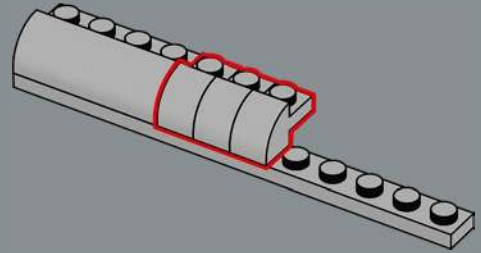

16

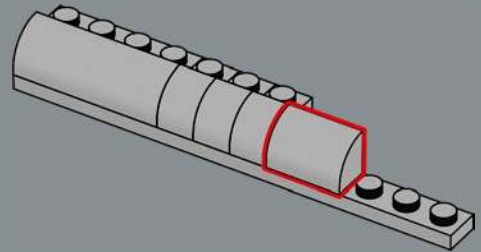

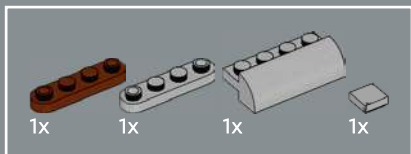

17

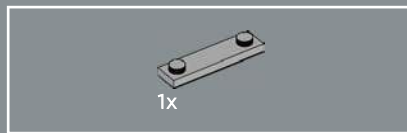
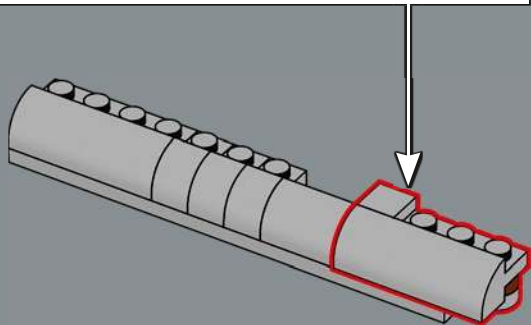
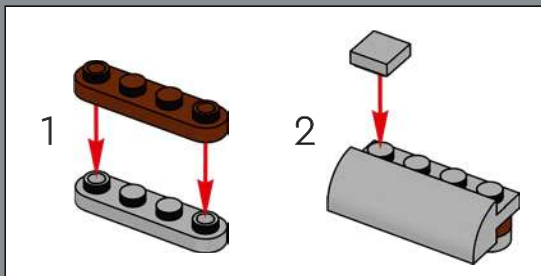

18

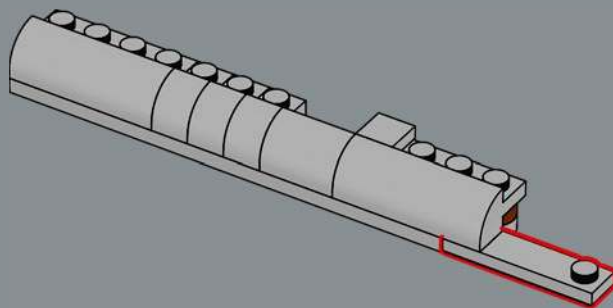

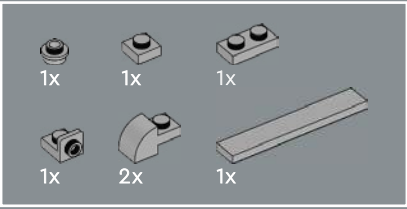
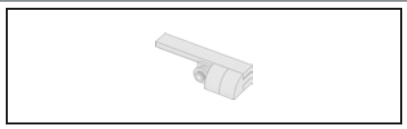

19

1

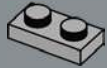

2



3



4

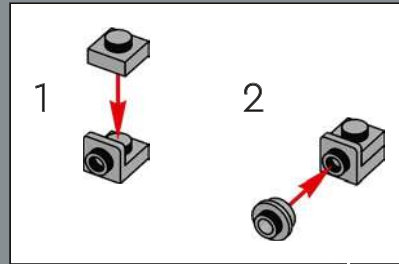
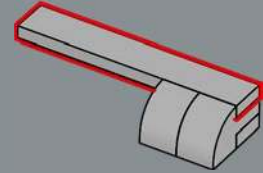

5

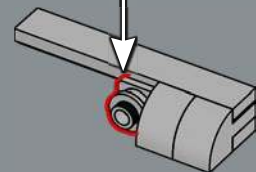

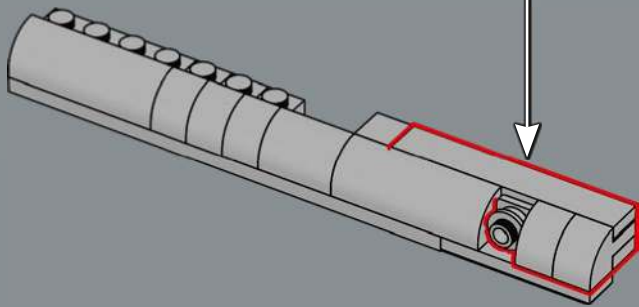

20

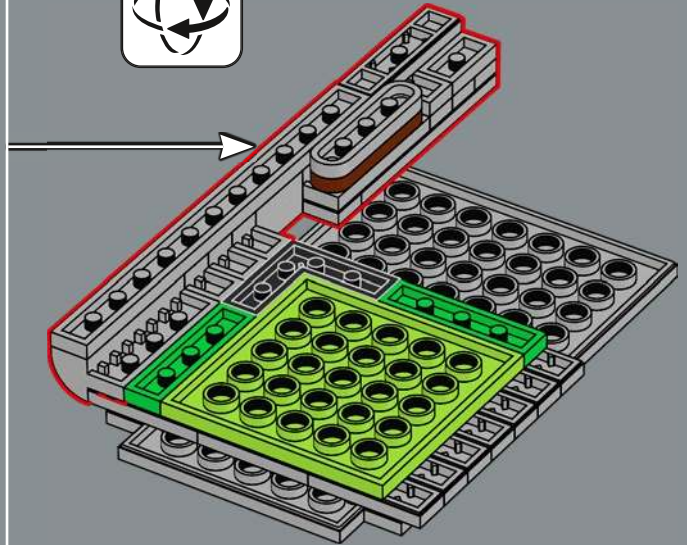

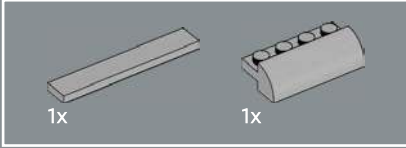
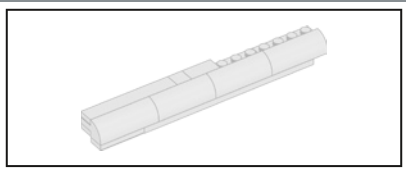

21

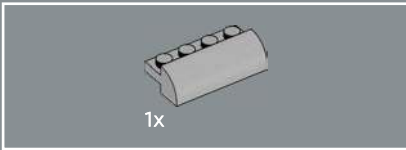
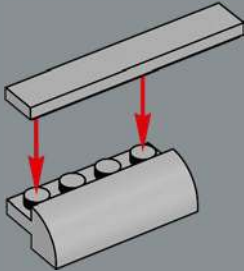

22

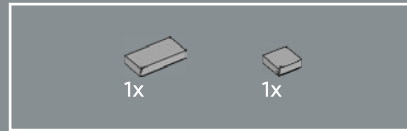
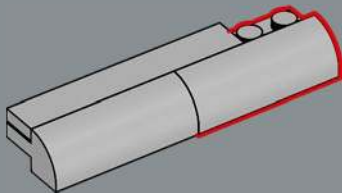

23

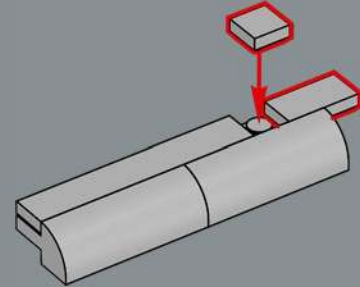

24

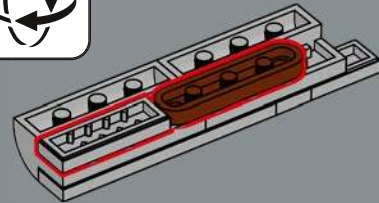

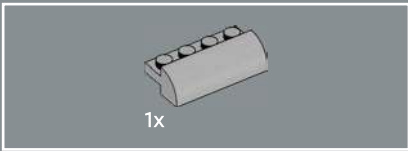

25

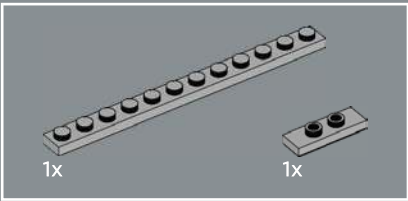
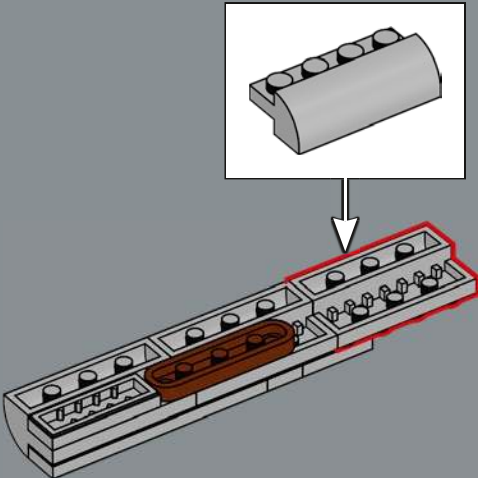

26

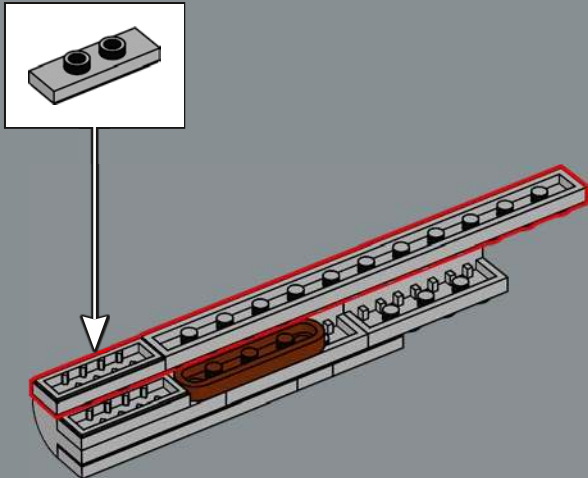

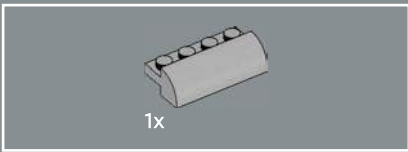

27

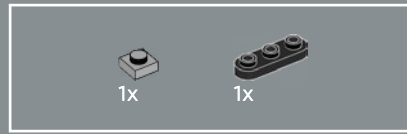
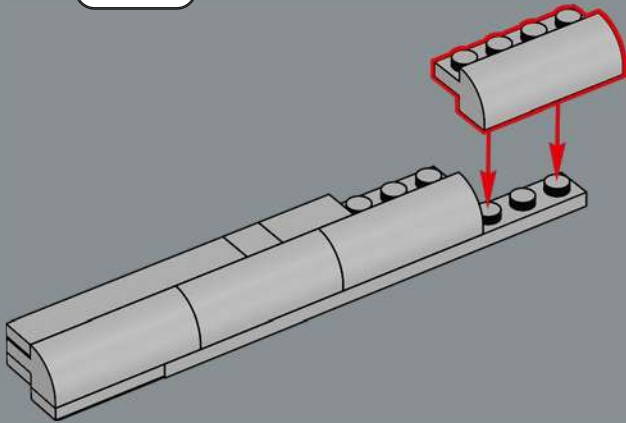

28

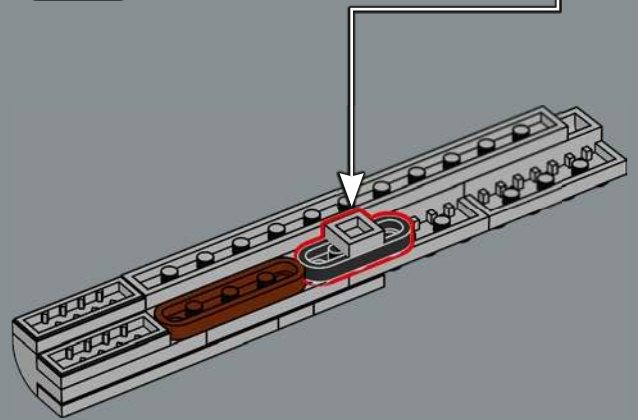
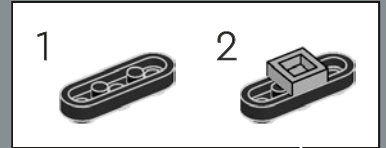

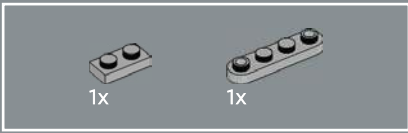

29

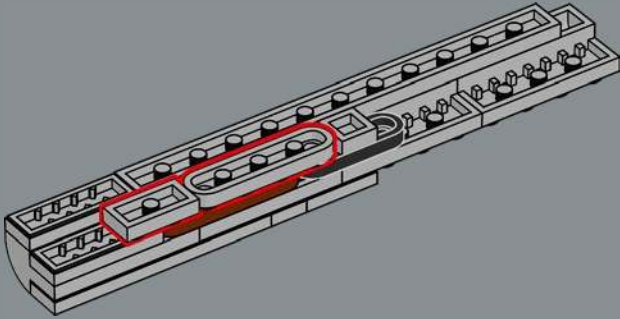

30

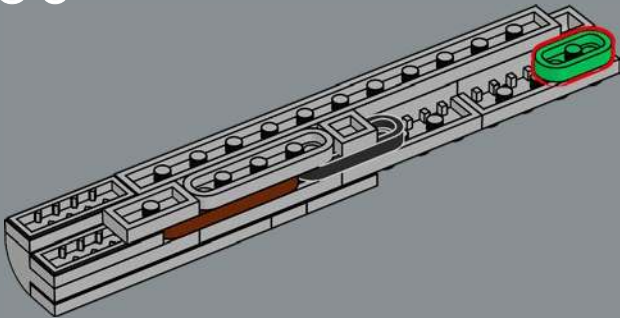

31

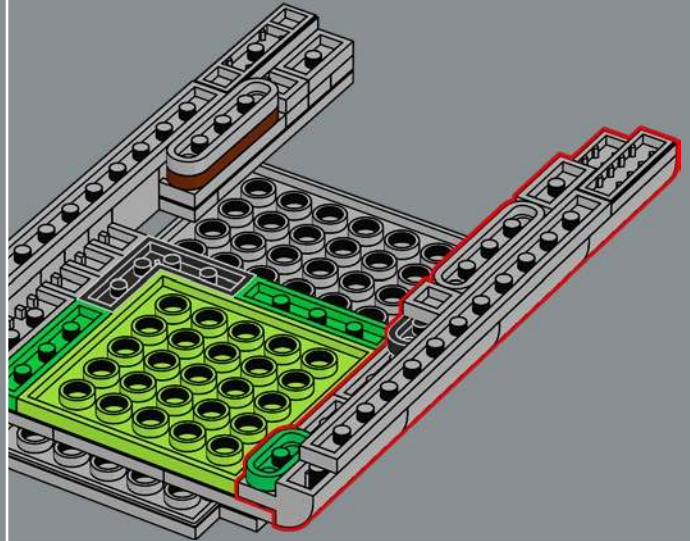

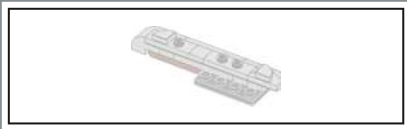

34

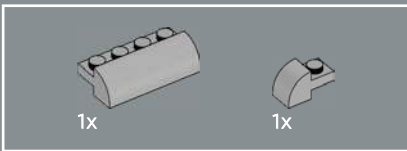
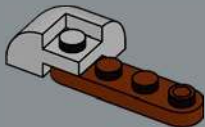

35

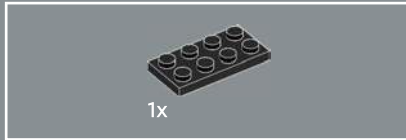
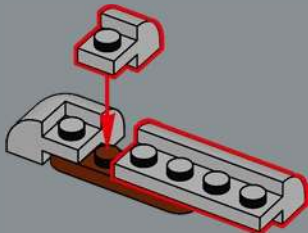

36

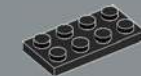

1x

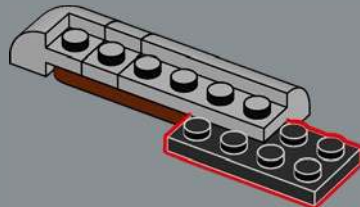

37

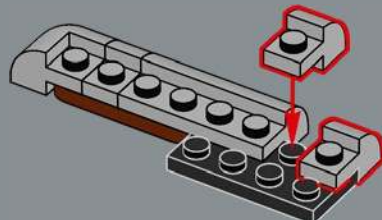

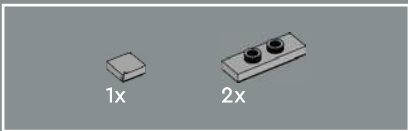

38

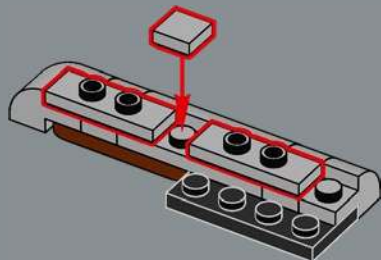

39

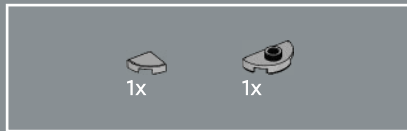
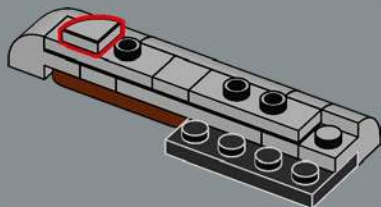

40

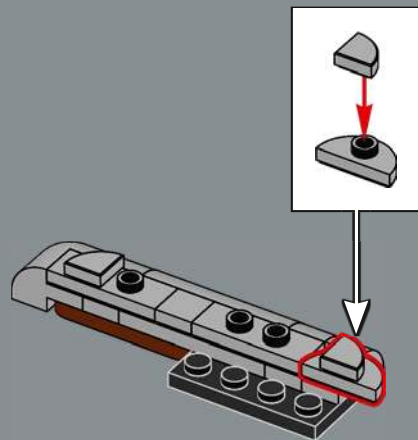

41

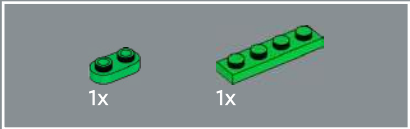
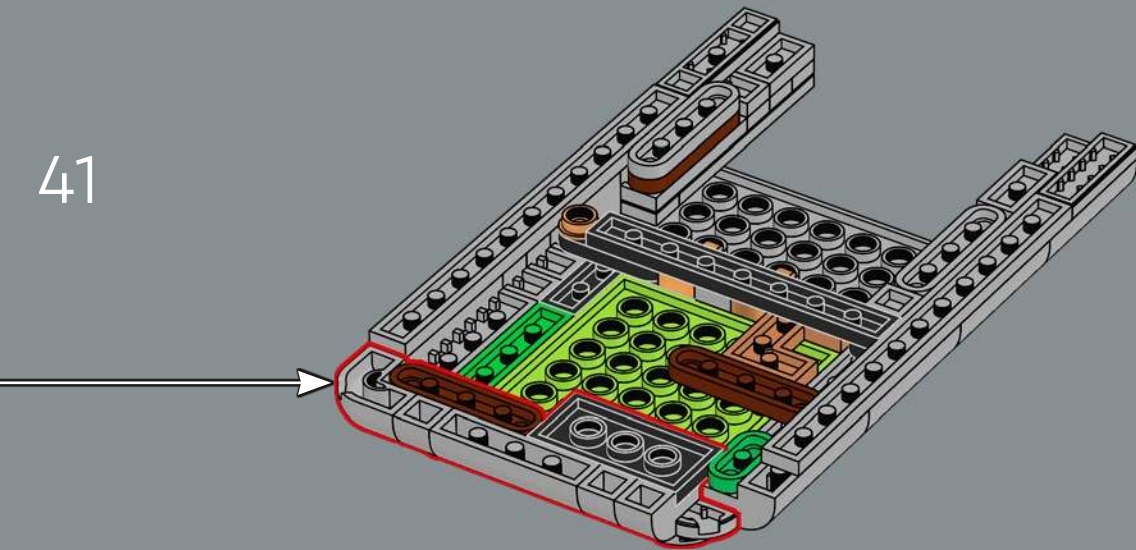

42

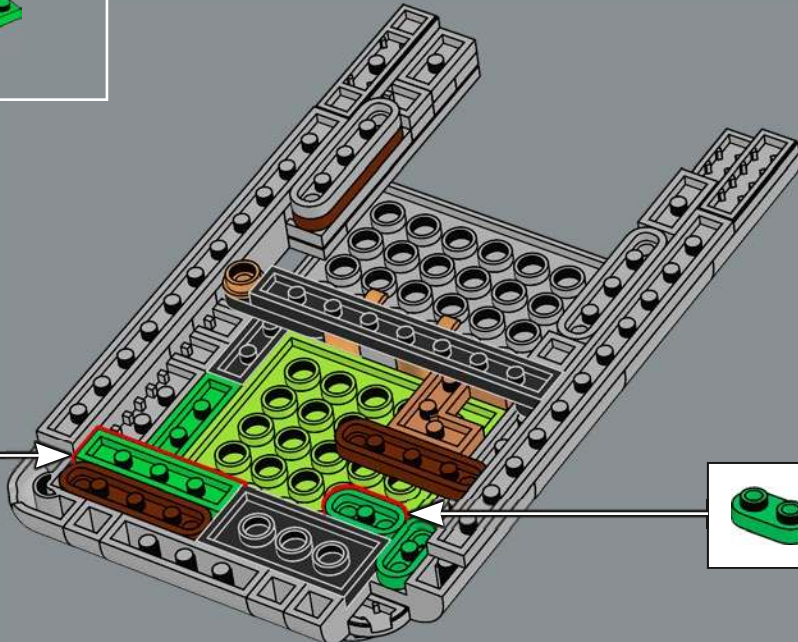
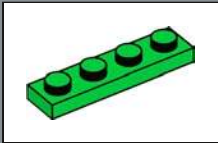

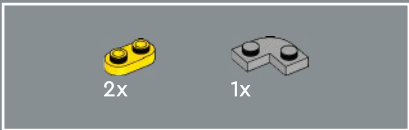

43

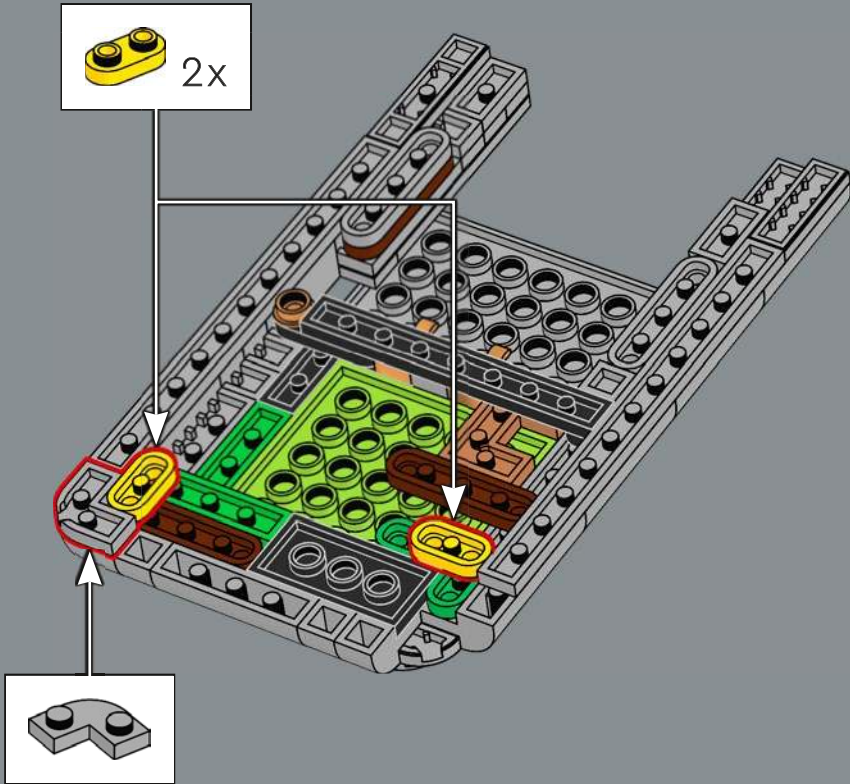

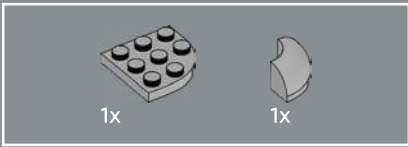

44

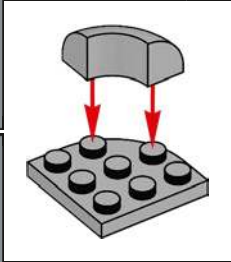
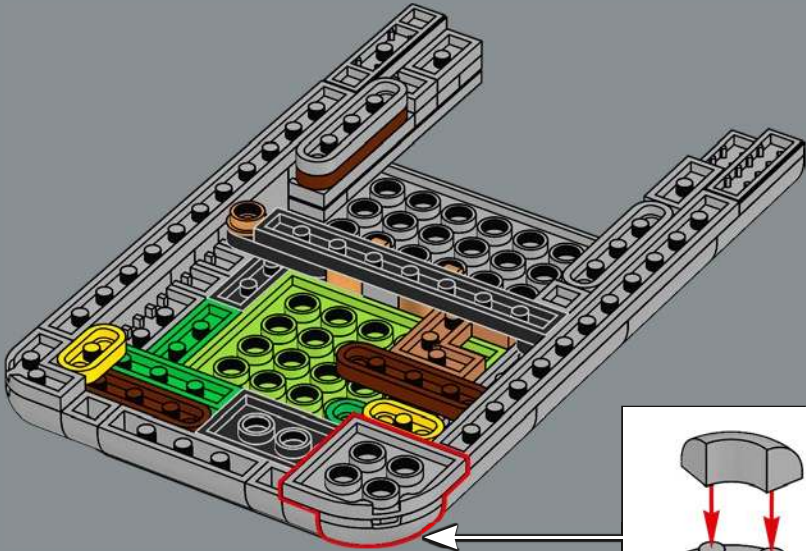

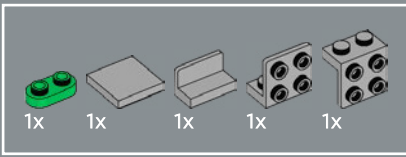

45

1

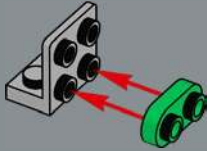

2

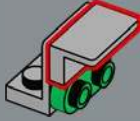

3

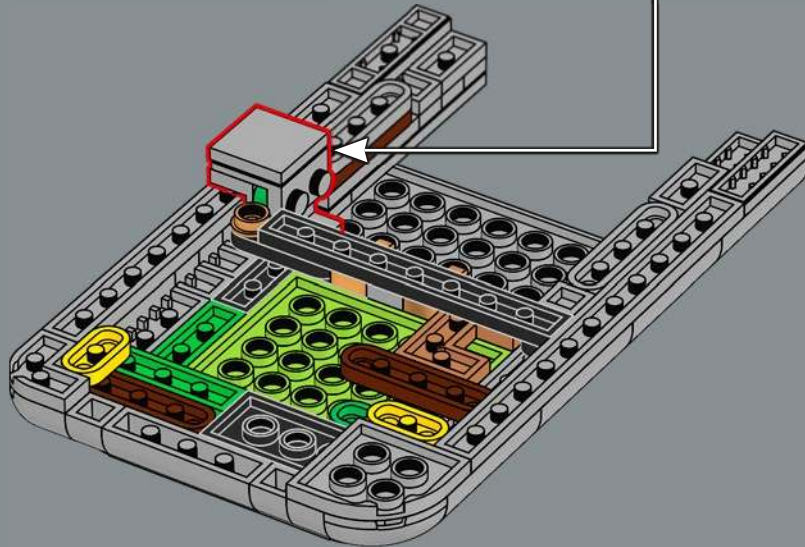
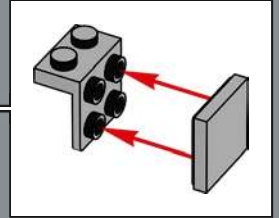
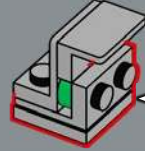

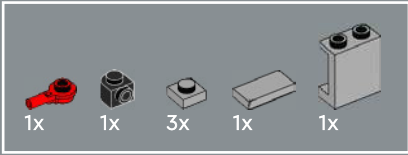
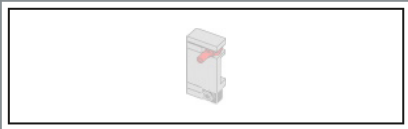

46

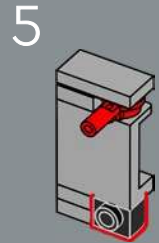
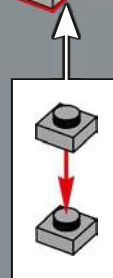
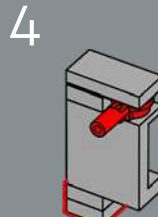
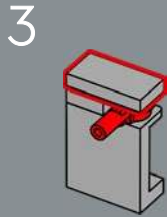
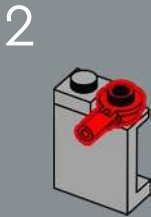
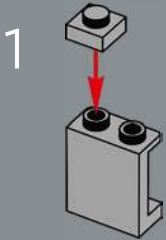

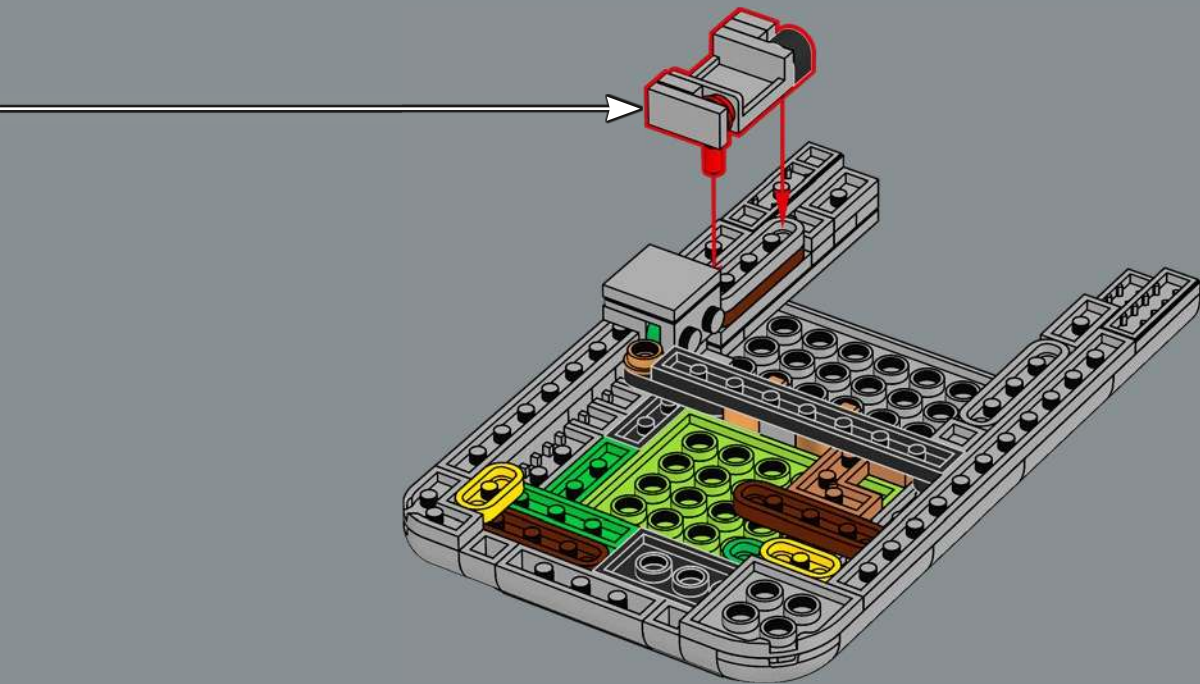

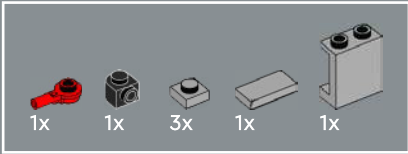
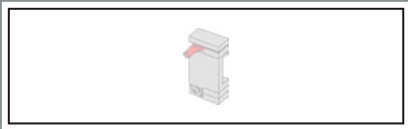

47

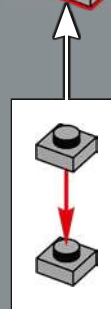
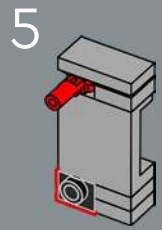
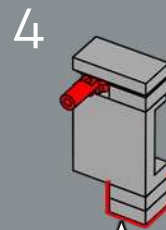
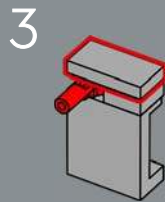
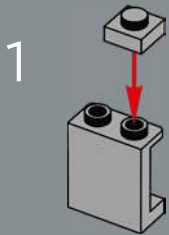

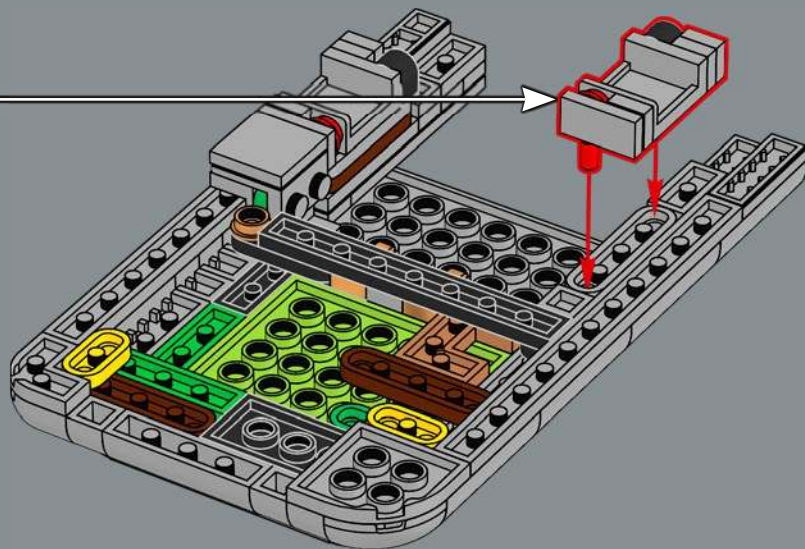



48

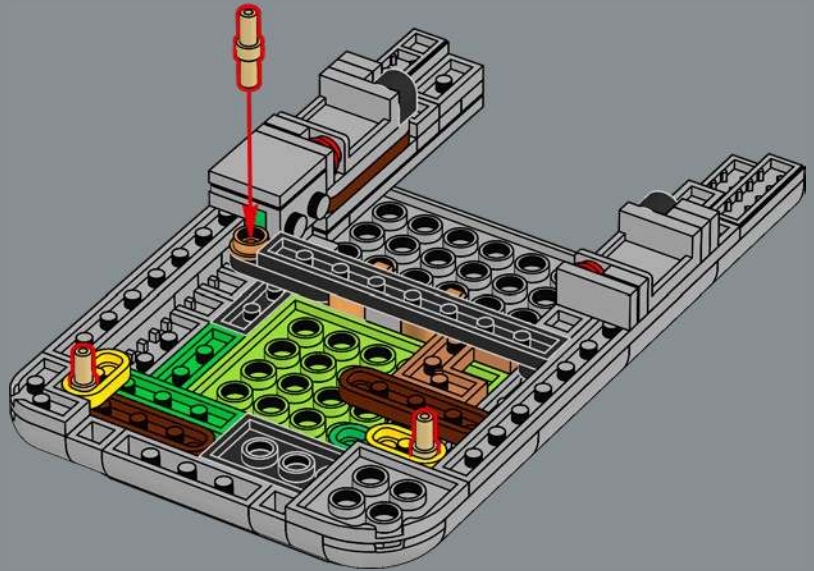

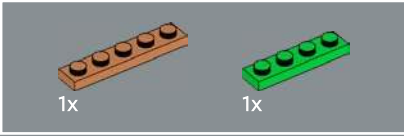

49

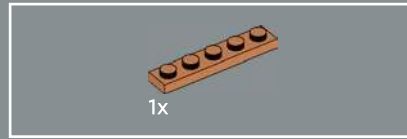
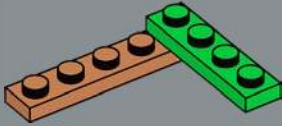

50

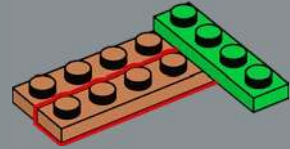



51

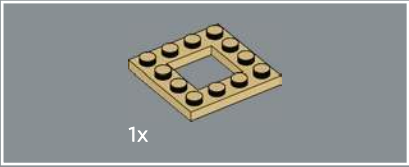
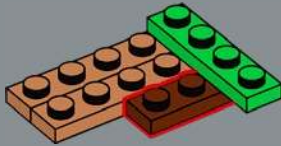

52

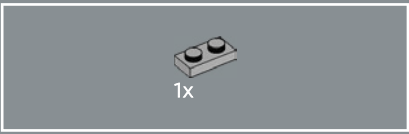
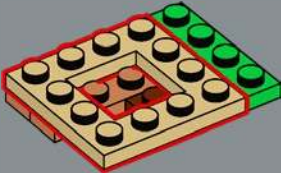

53

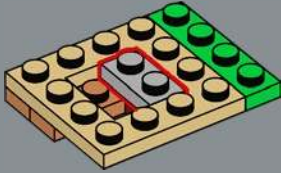

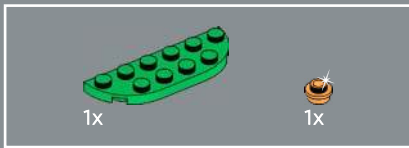

54

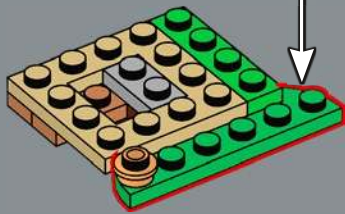
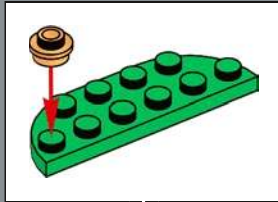

55

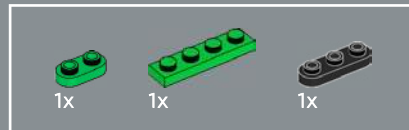
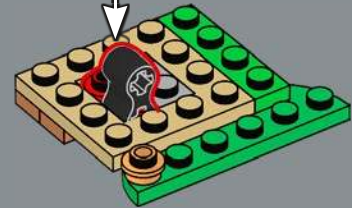
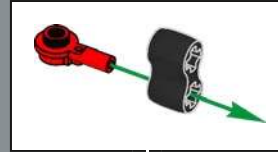

56

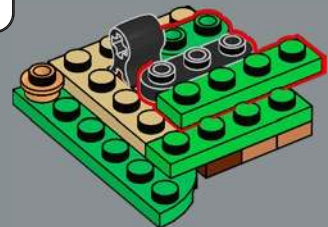



57

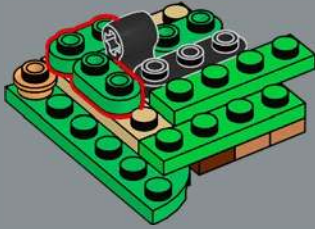

58

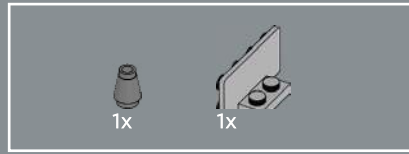
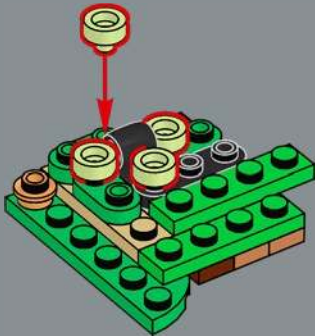

59

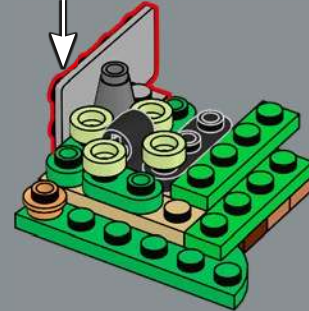
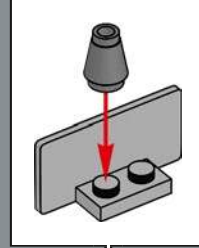



60

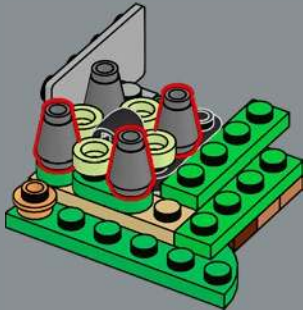

61

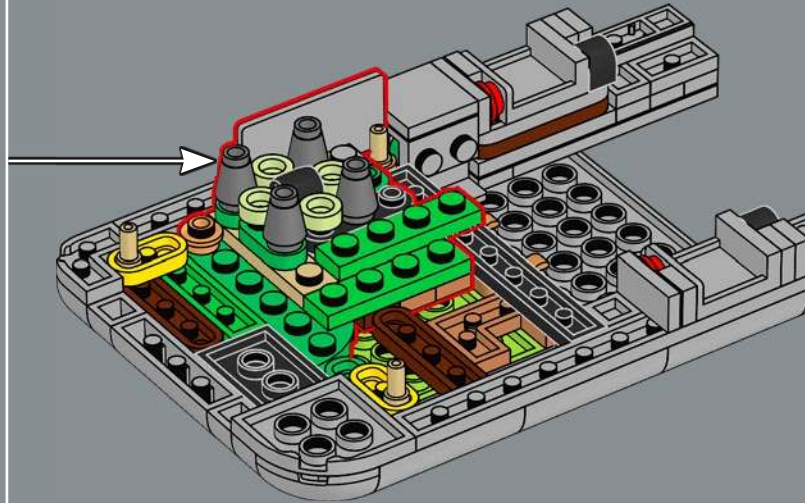

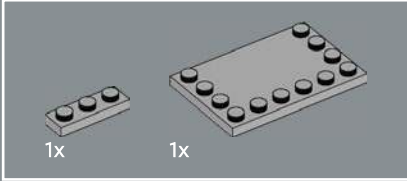
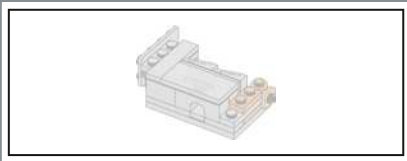

62

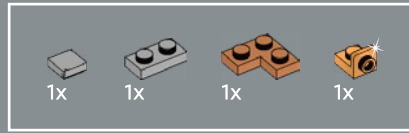
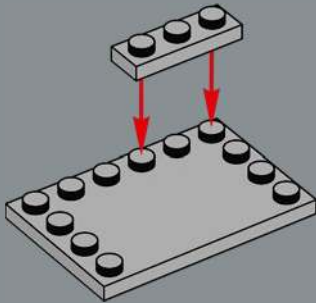

63

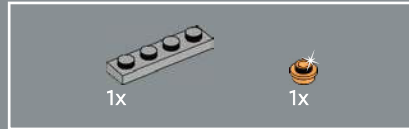
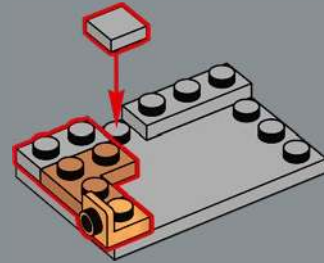

64

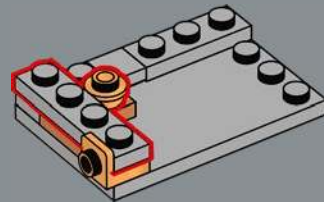



68

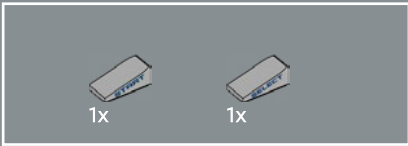
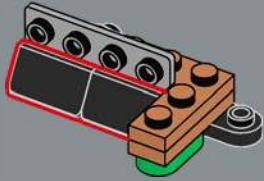

69

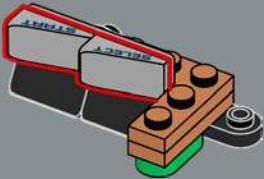

70

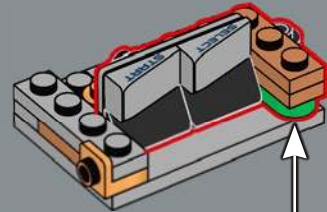

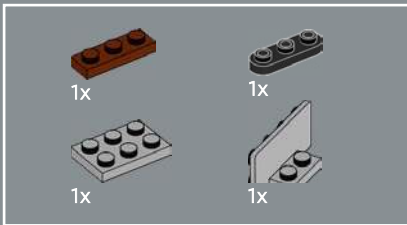

71

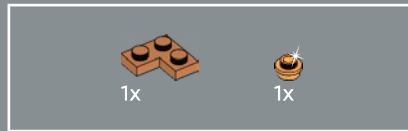
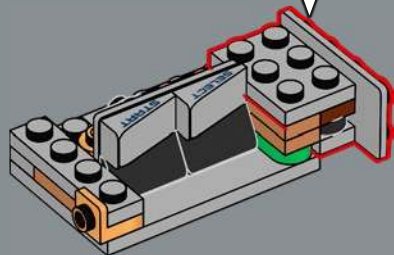
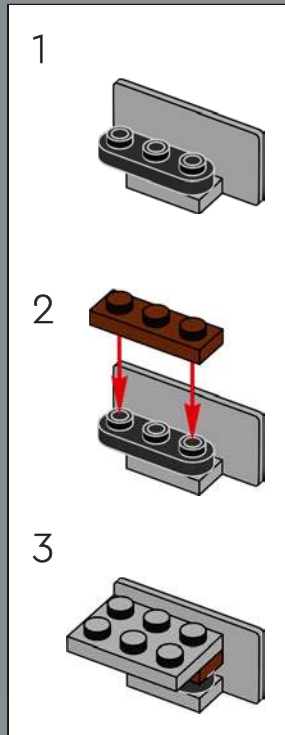

72

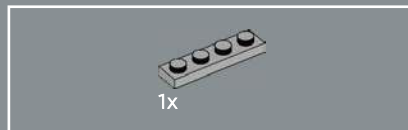
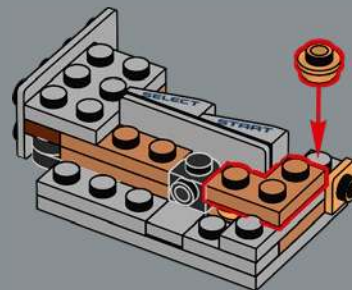

73

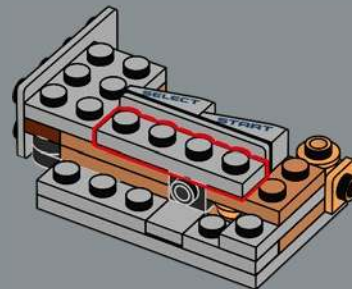

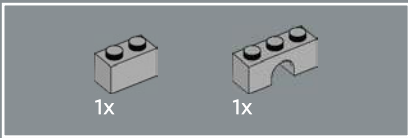

74

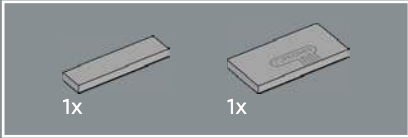
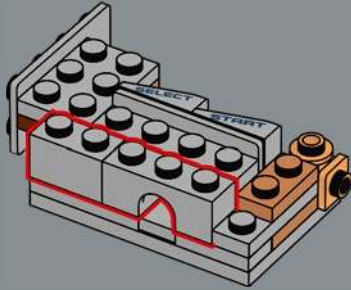

75

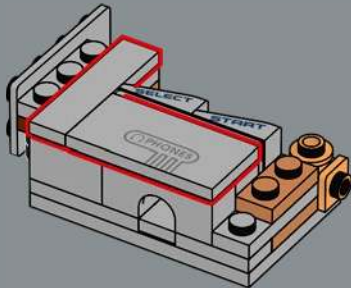

76

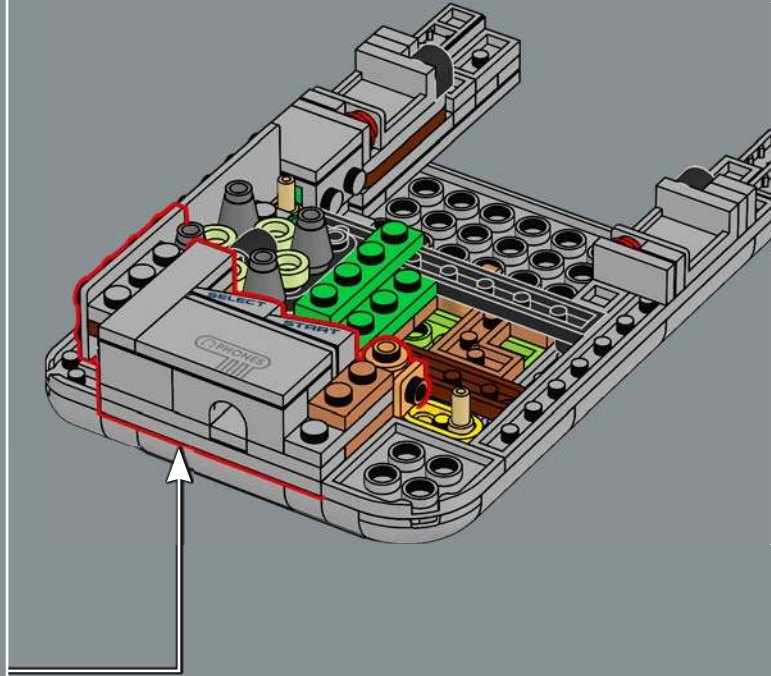

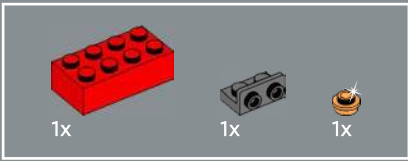

77

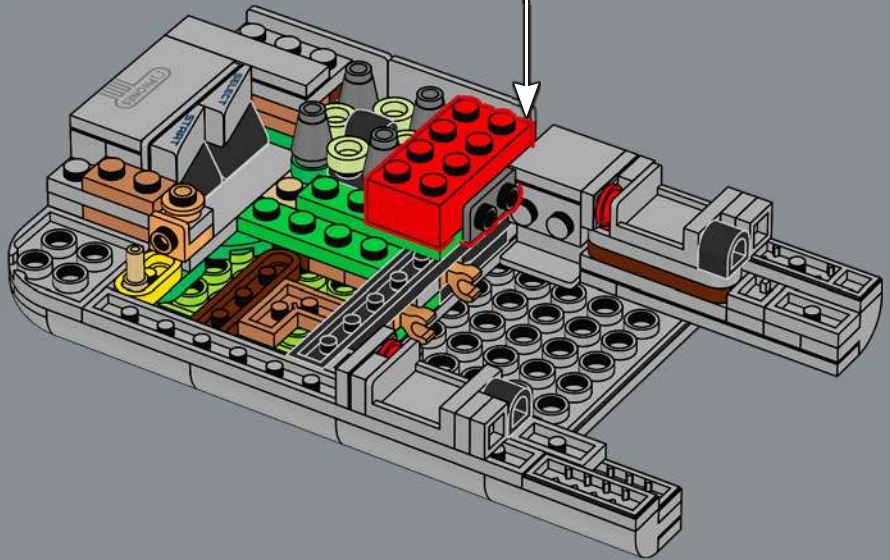
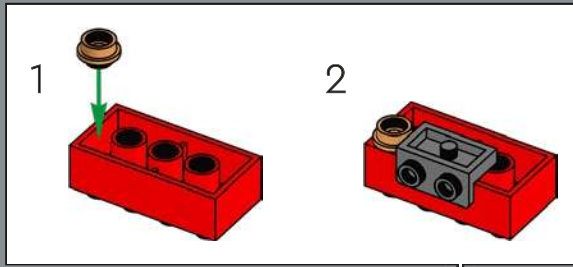

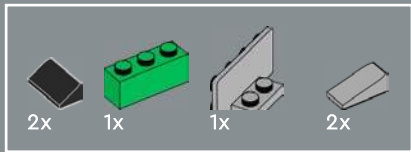

78

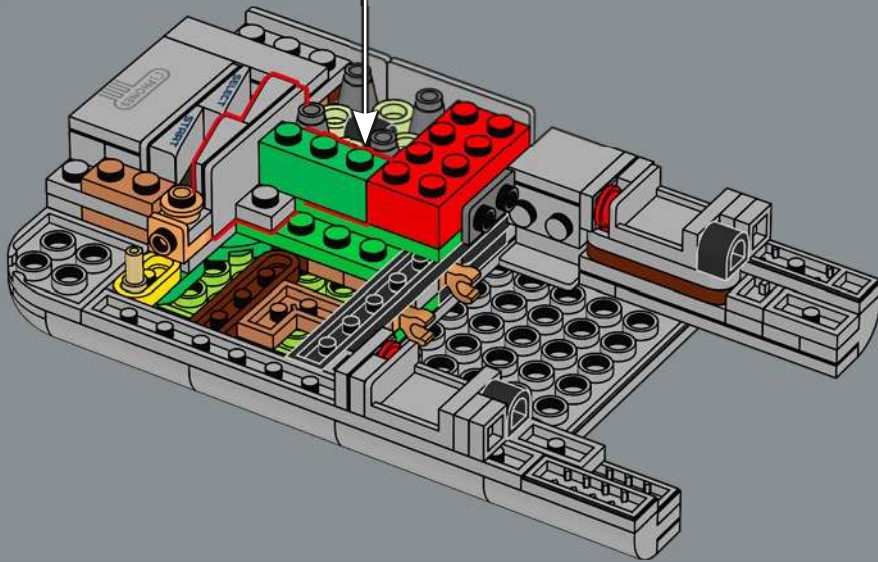
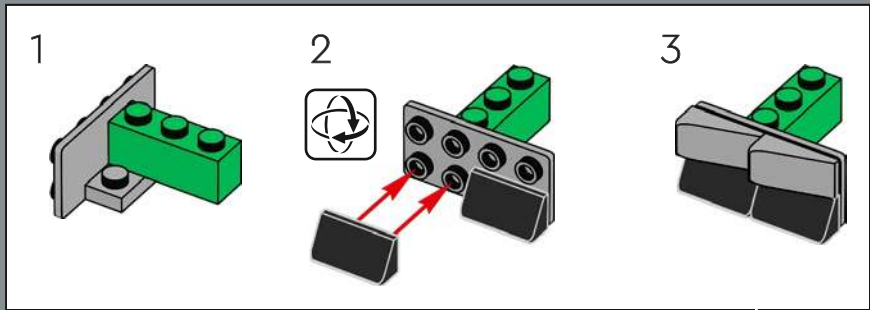



79

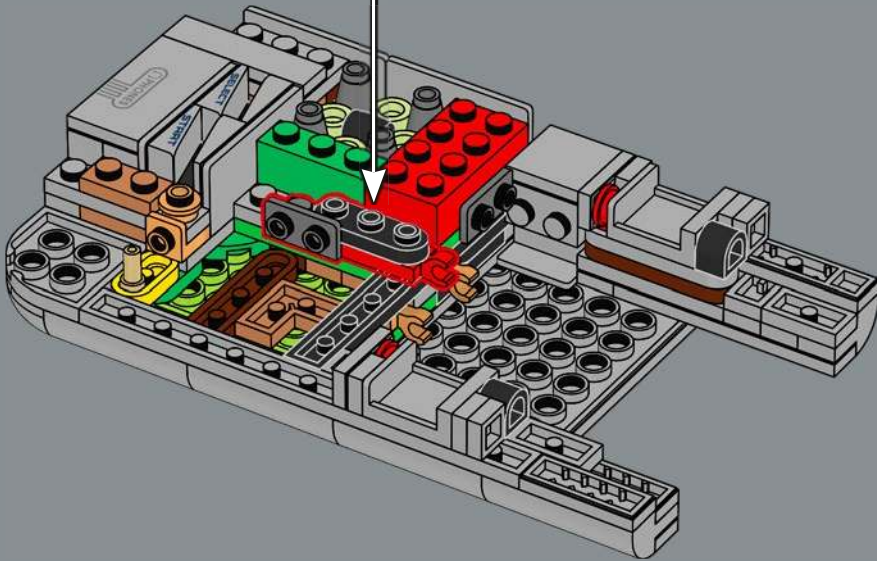
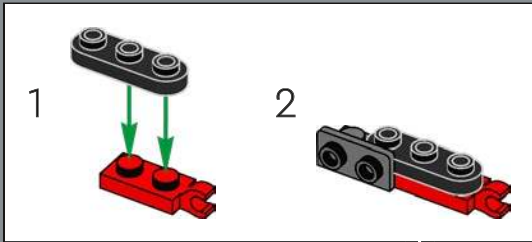

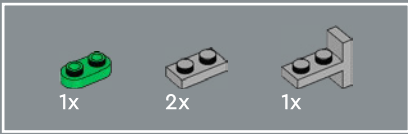

80

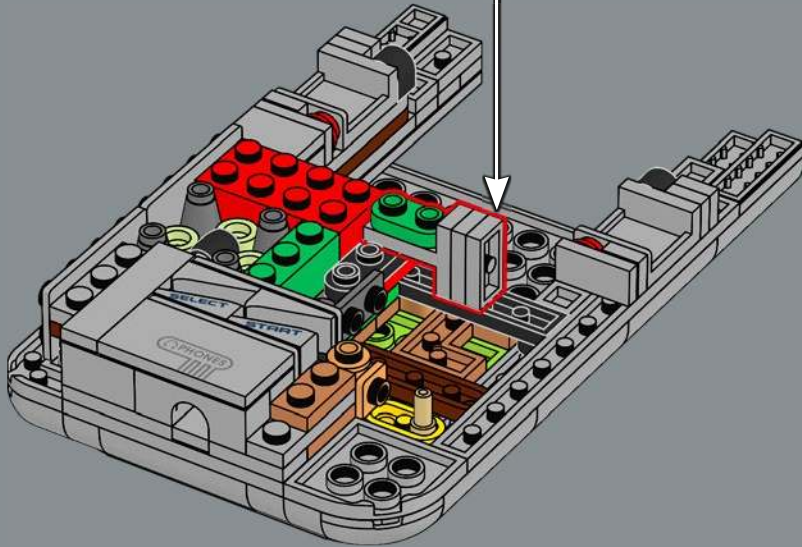
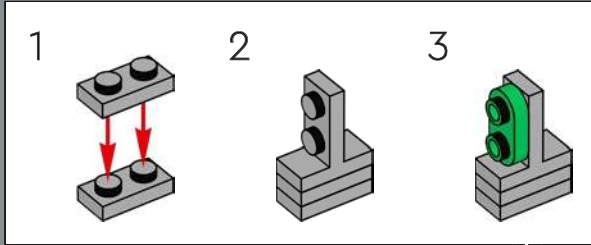

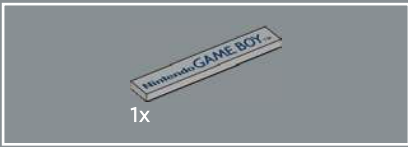

81

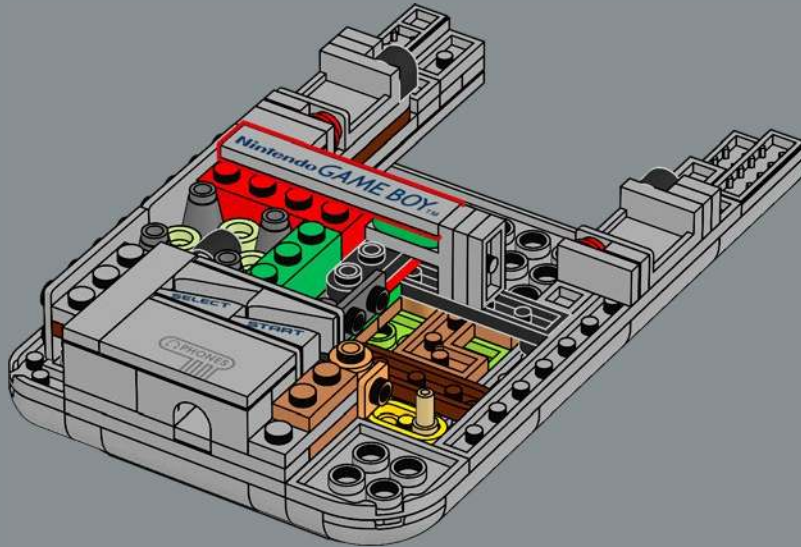

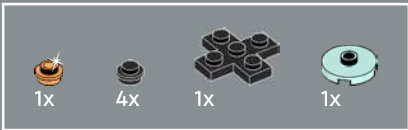

82

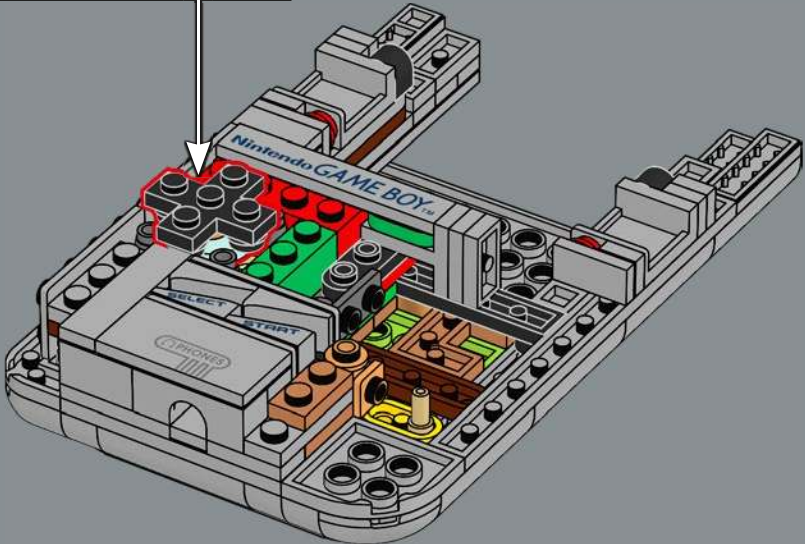
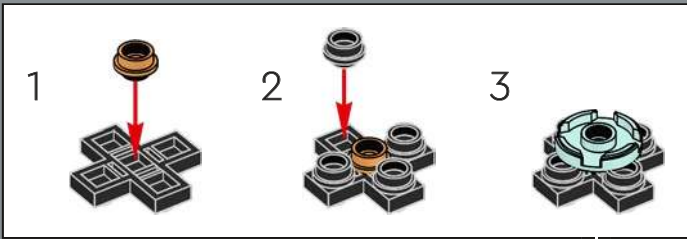

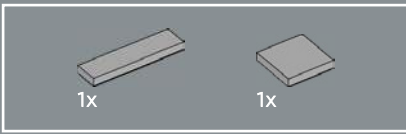

83

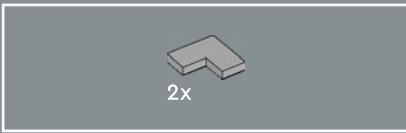
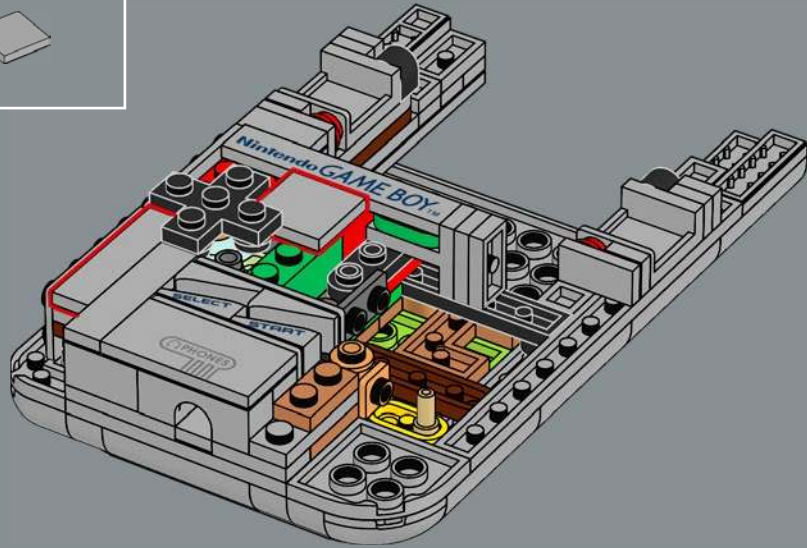

84

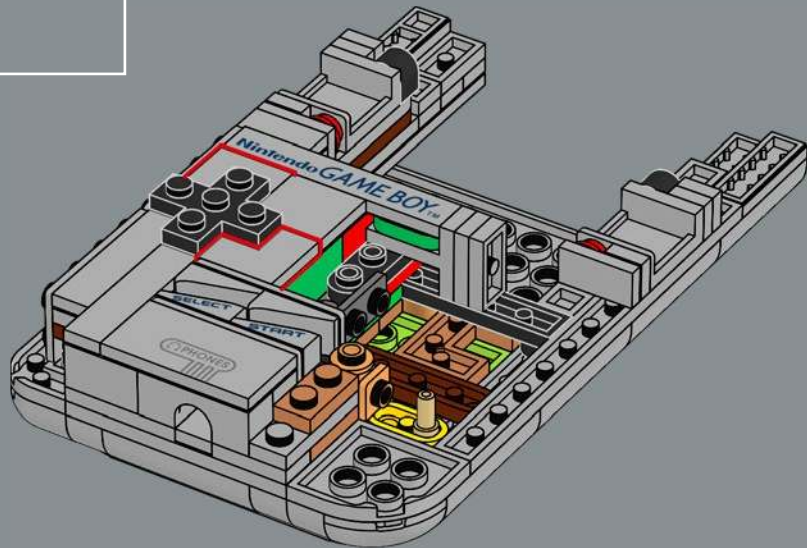

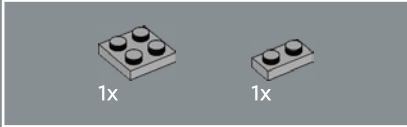
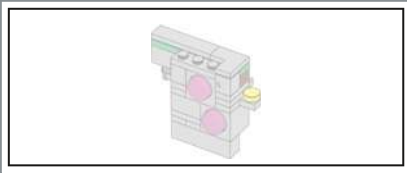

85

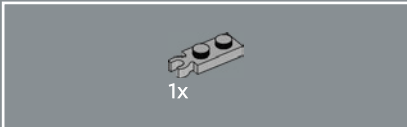
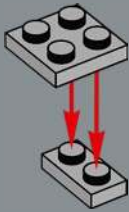

86

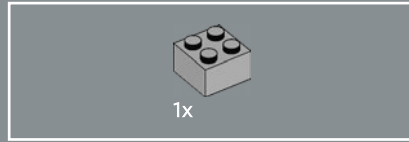
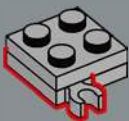

87

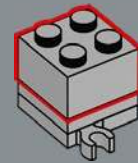

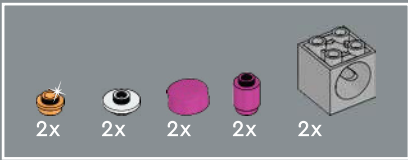

88

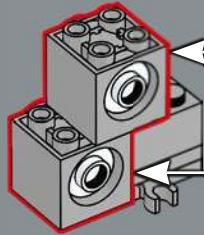
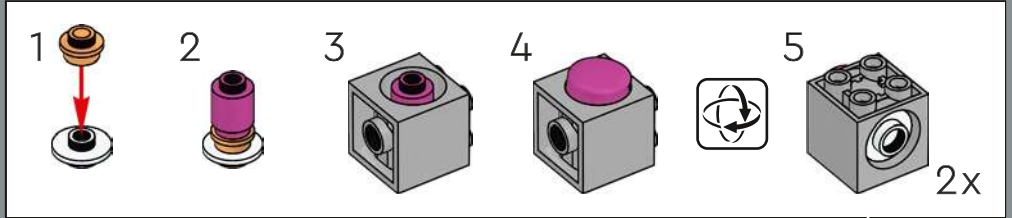

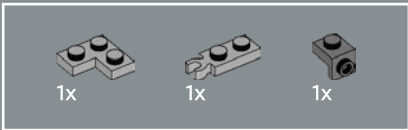

89

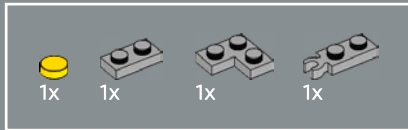
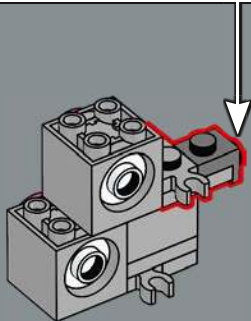
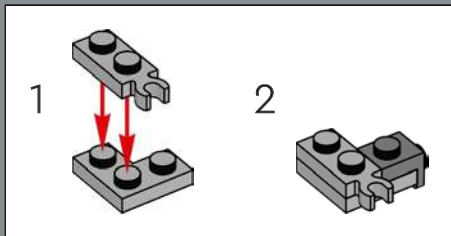

90

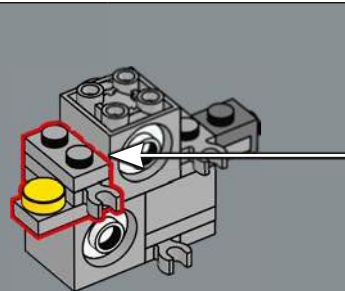
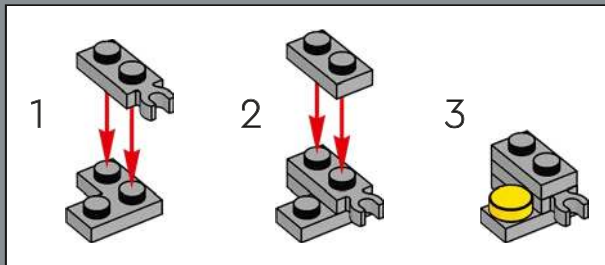

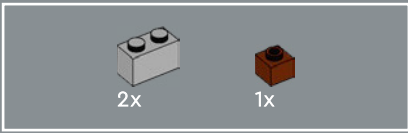

91

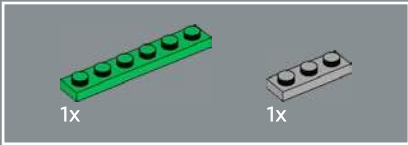
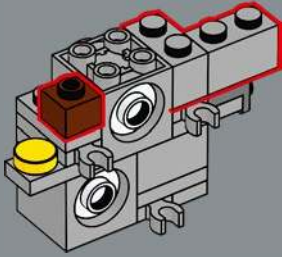

92

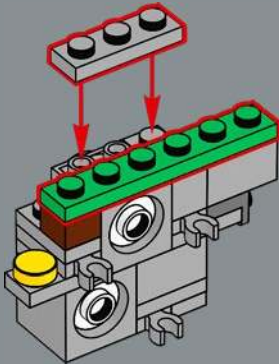

93

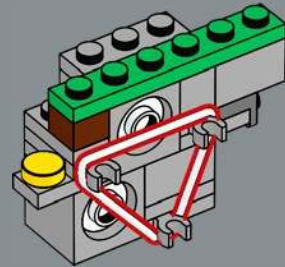



94

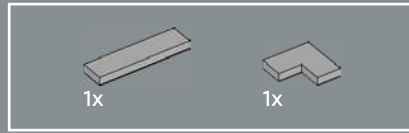
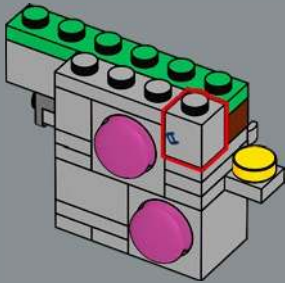

95

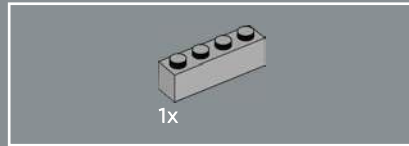
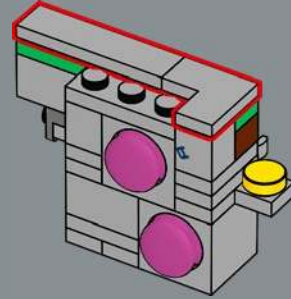

96

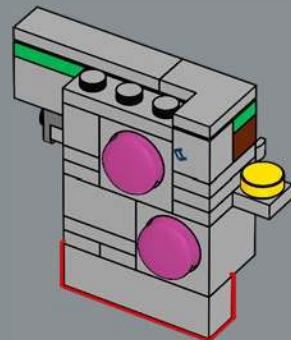

97

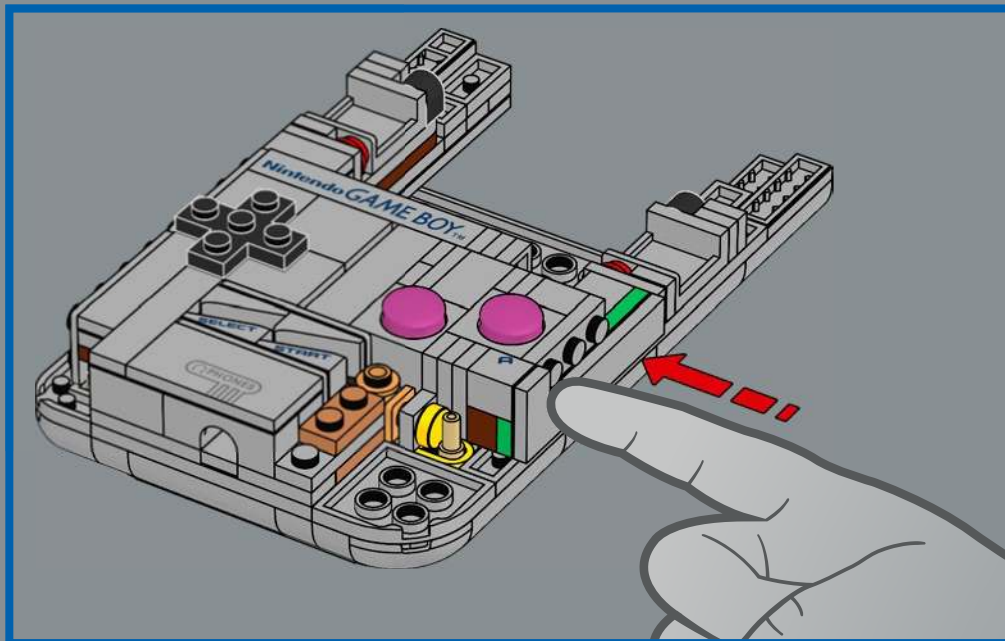
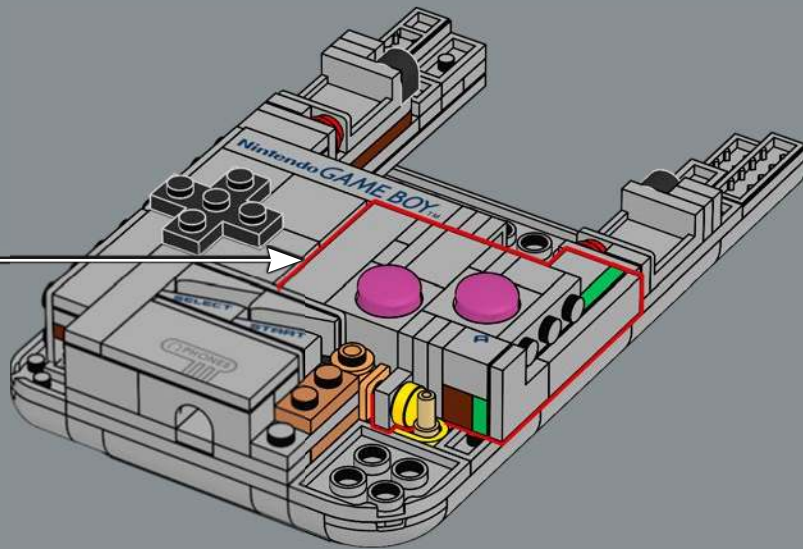

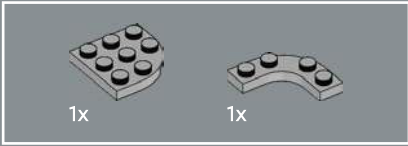

98

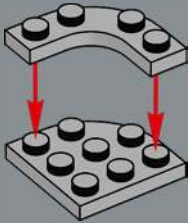

99

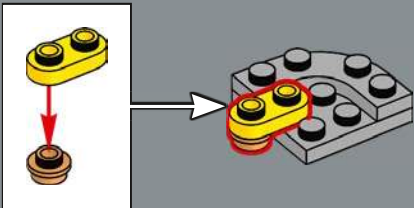

100

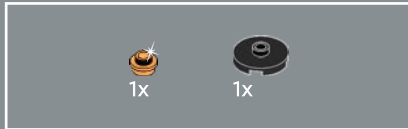

101



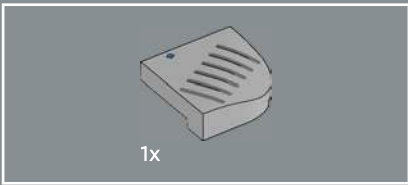

102

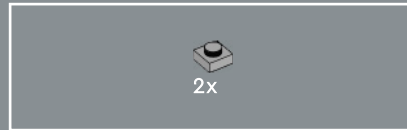
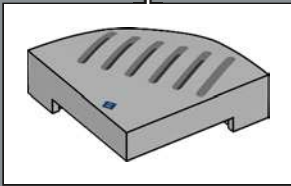
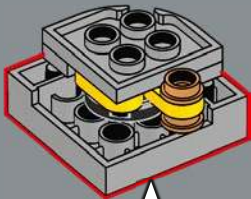

103

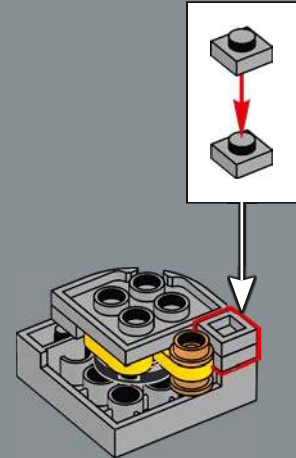

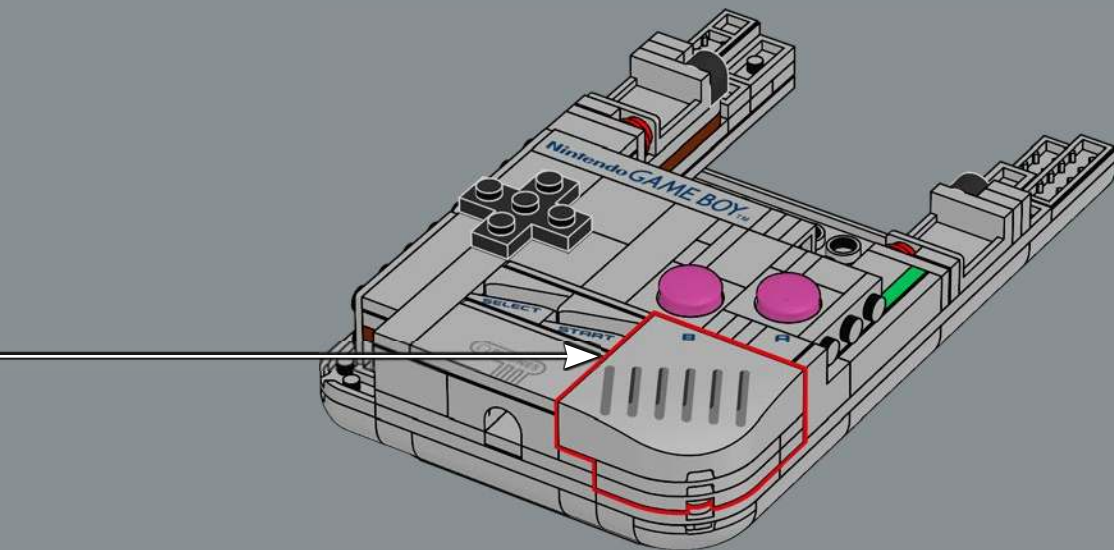

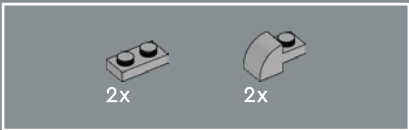

105

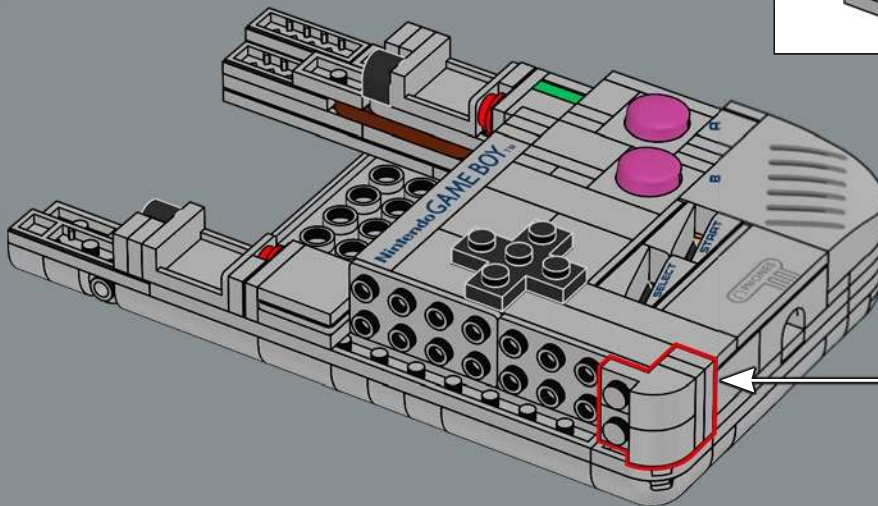
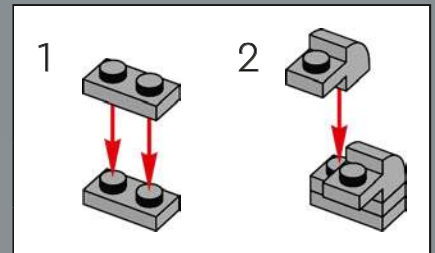

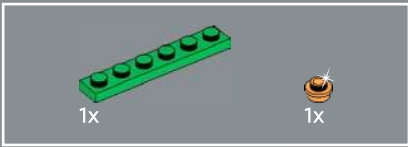

106

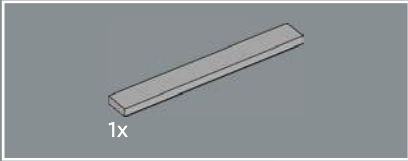
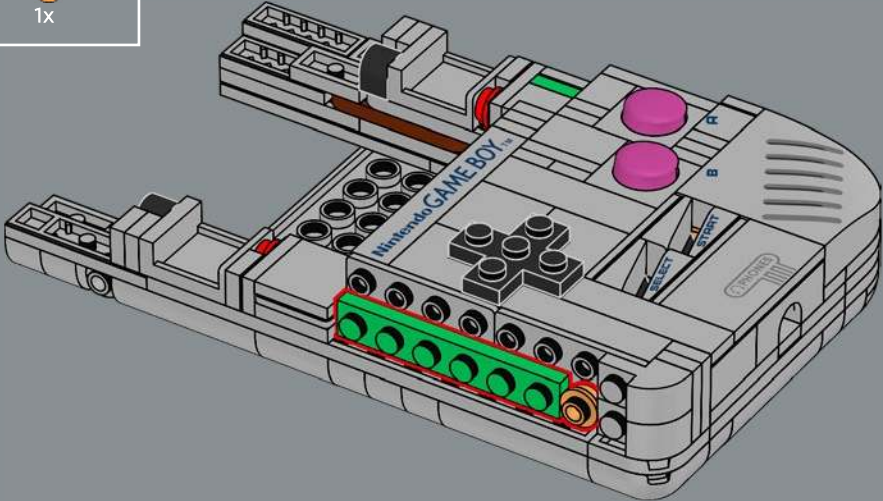

107

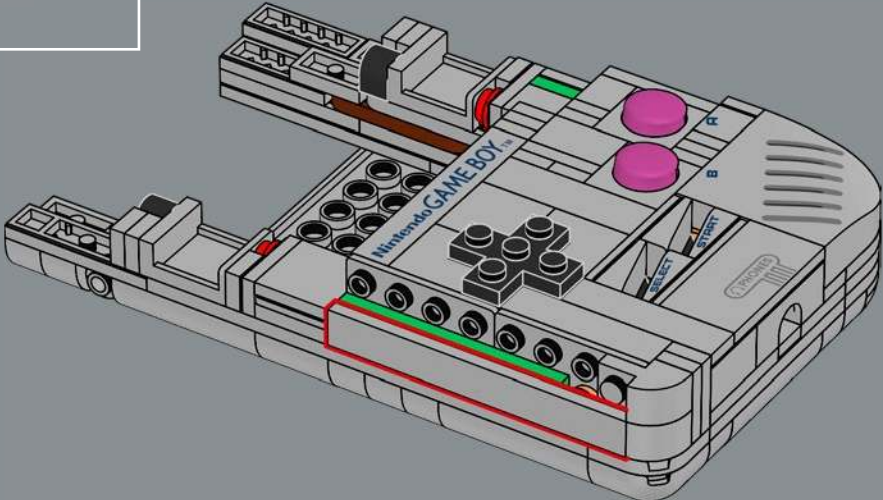



108

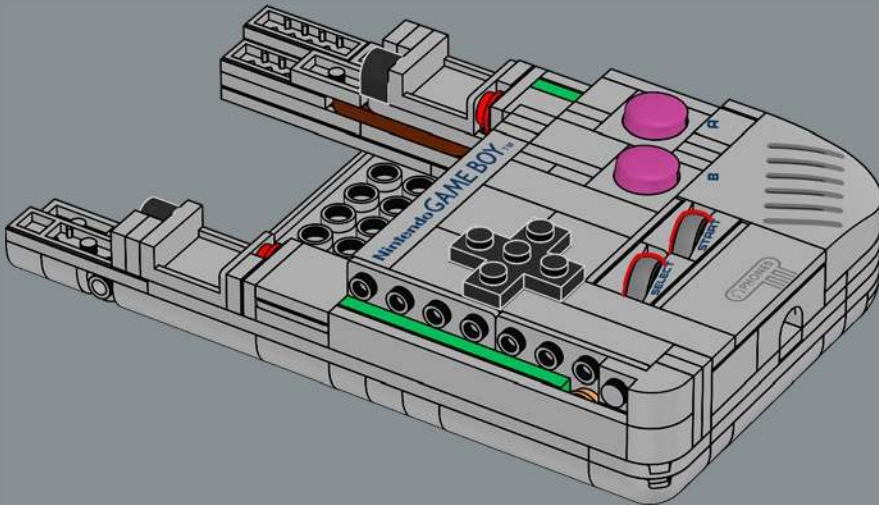

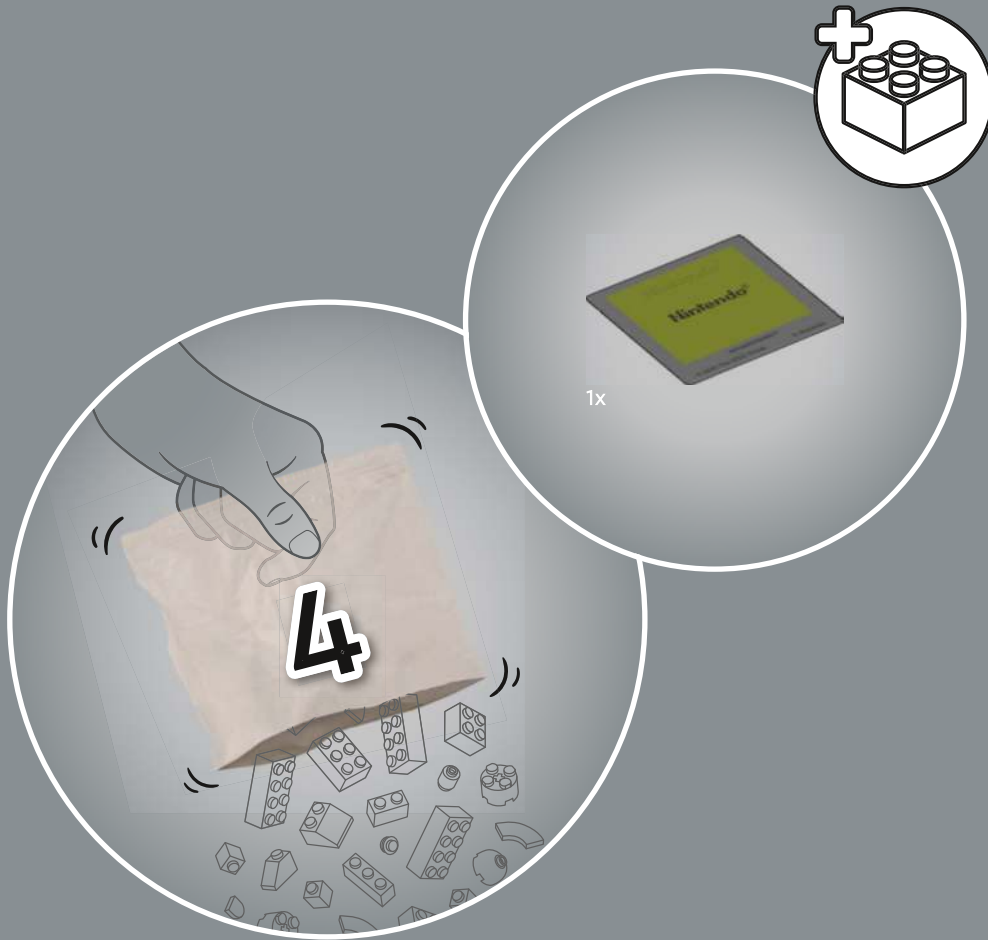

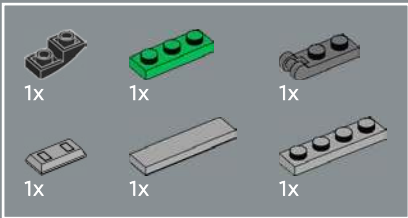

109

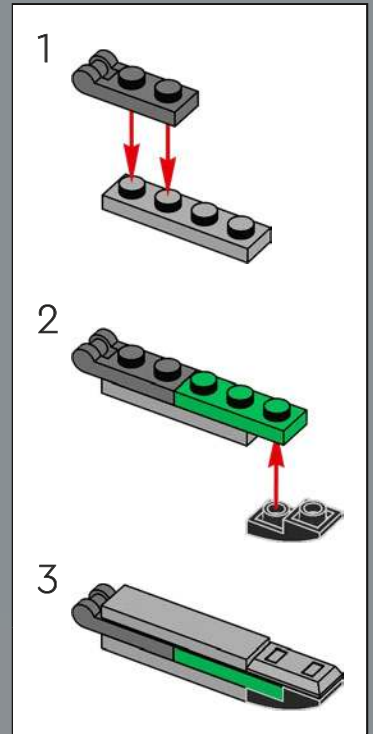
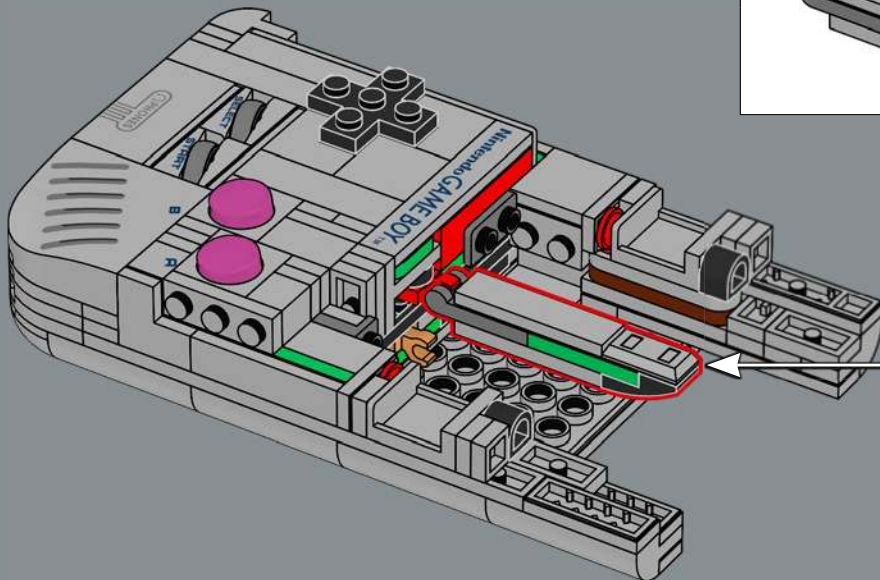

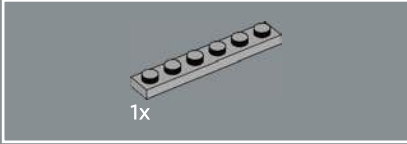
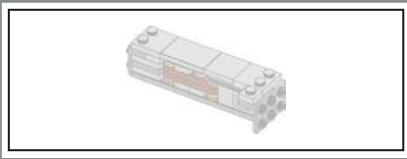

1x

110

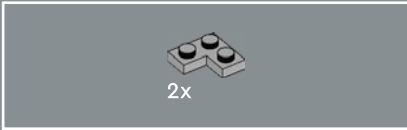
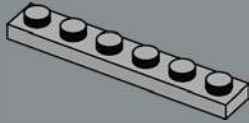

2x

111

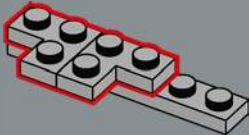

1x

112

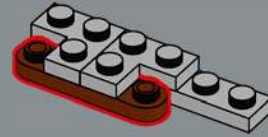

2x

113



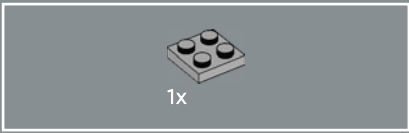

114

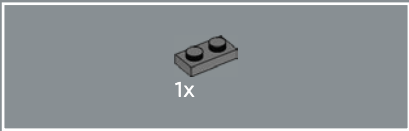
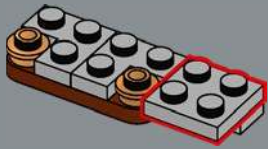

115

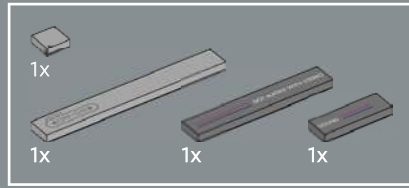
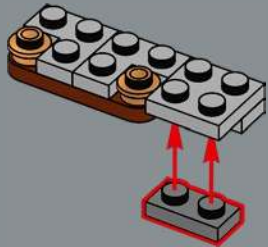

116

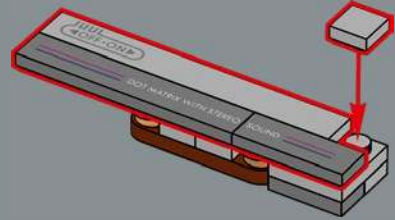

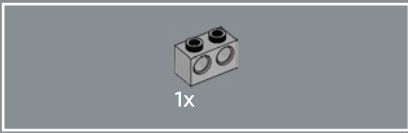

117

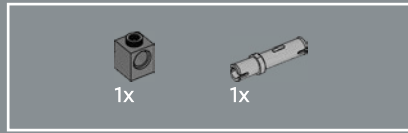
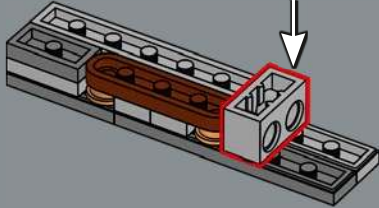
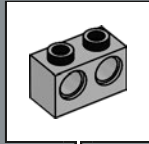

118

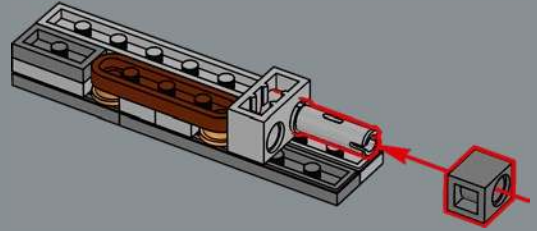

119

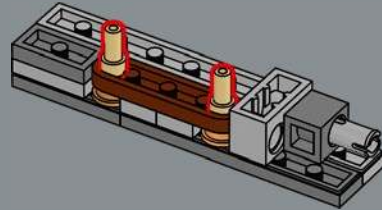

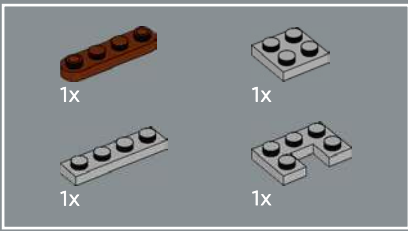

120

1



2

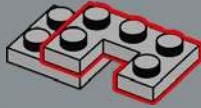

3

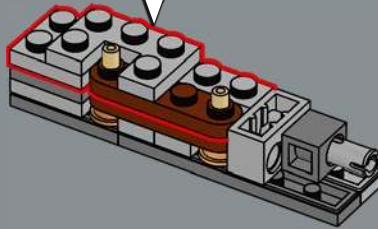
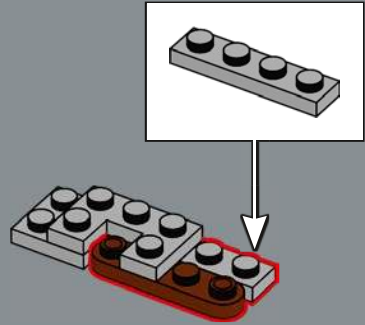

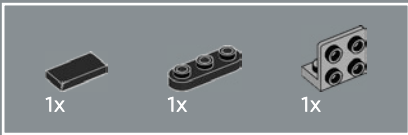

121

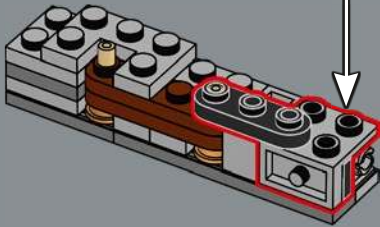
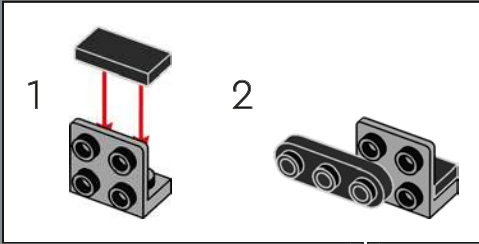

122

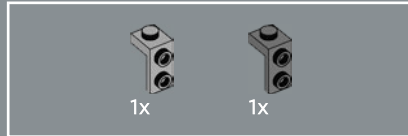
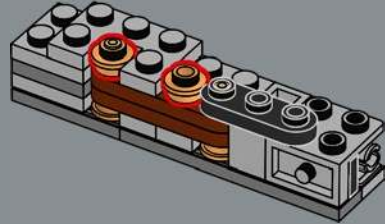

123

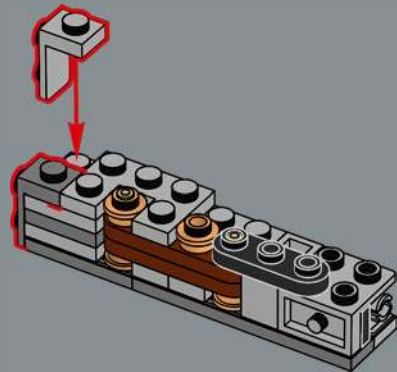

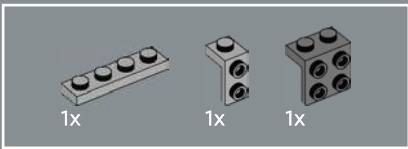

124

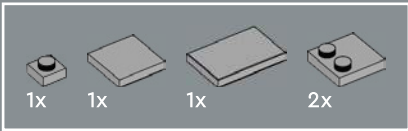
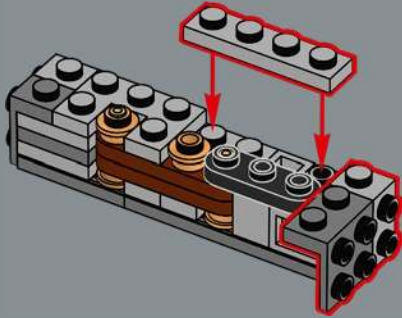

125

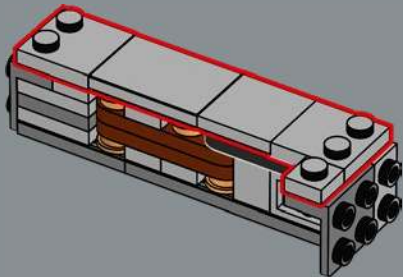

126

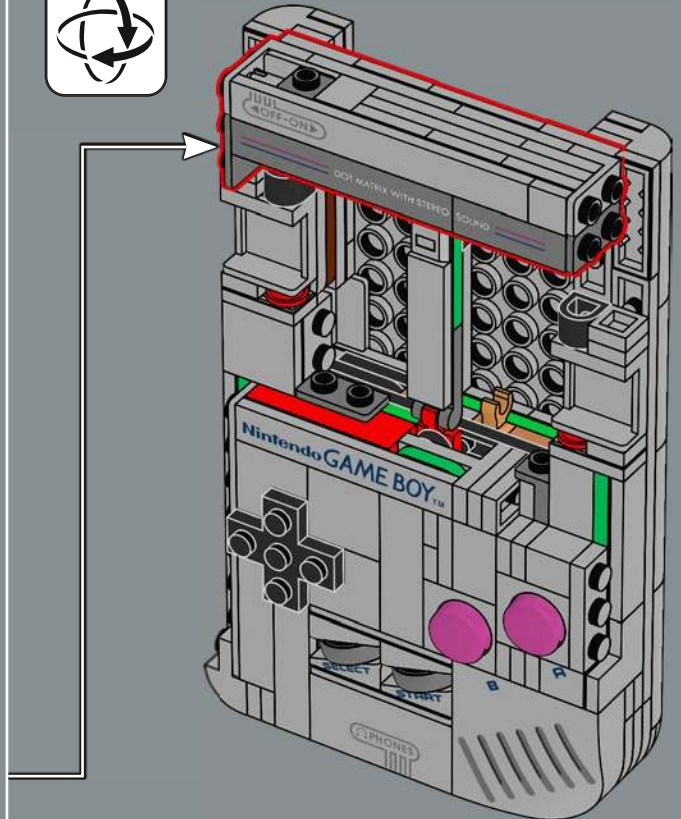

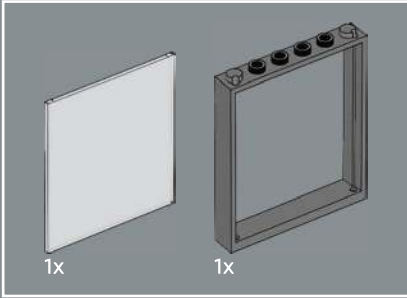
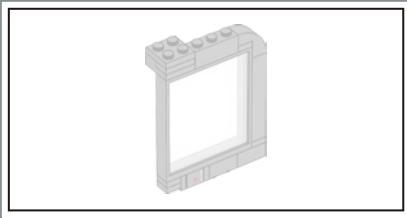

127

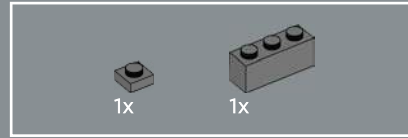
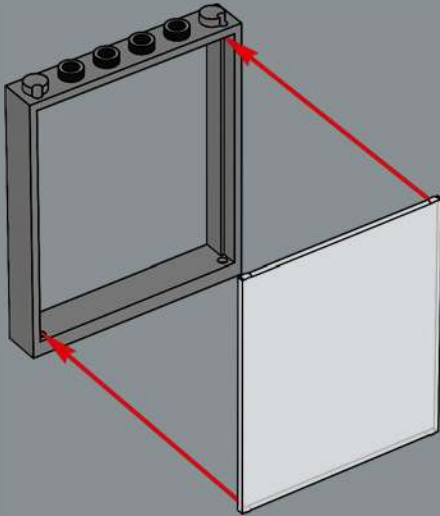

128

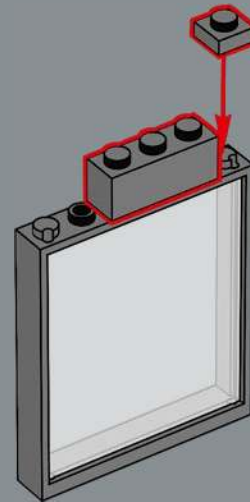

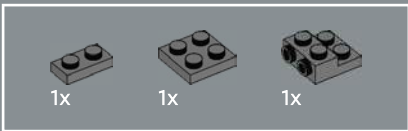

129

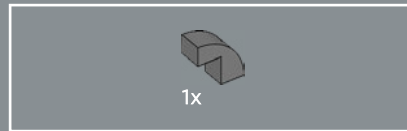
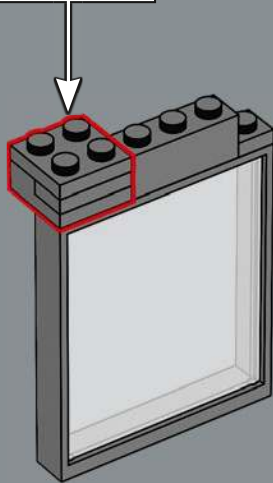
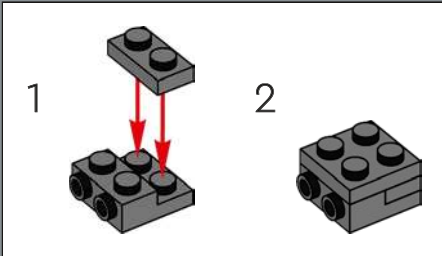

130

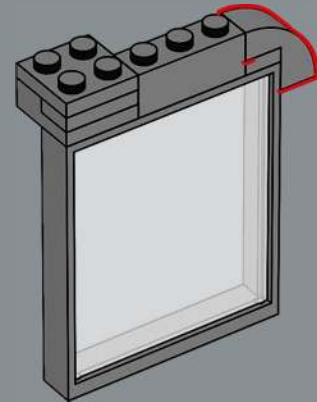

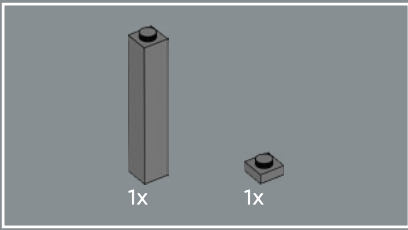

131

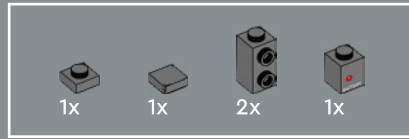
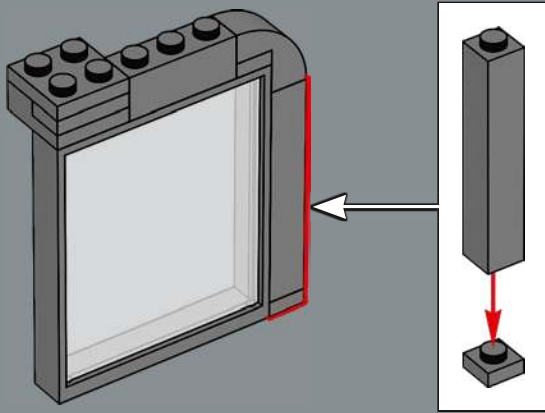

132

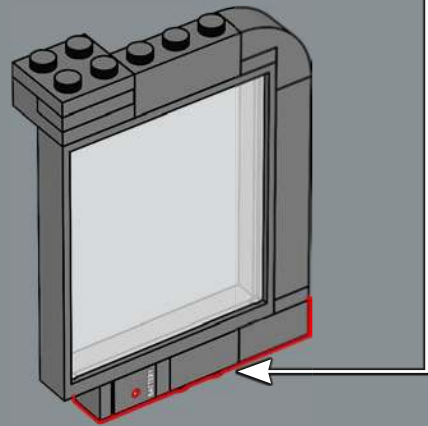
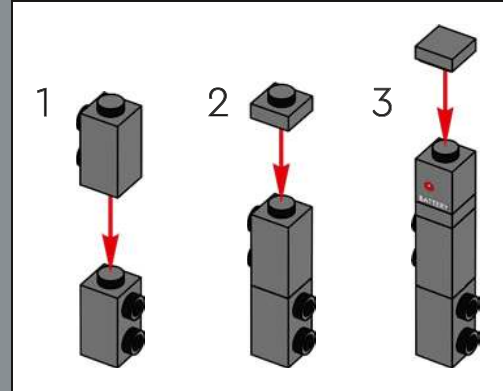

2x

133

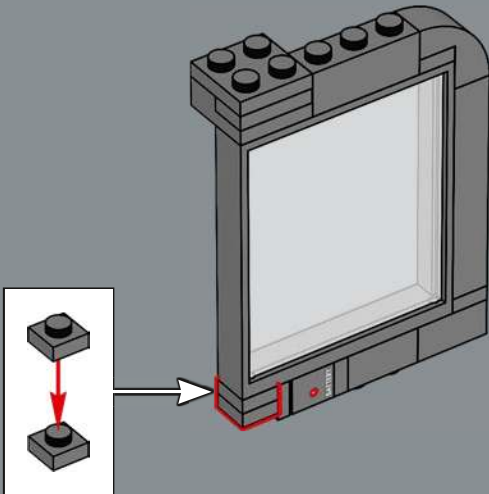

134

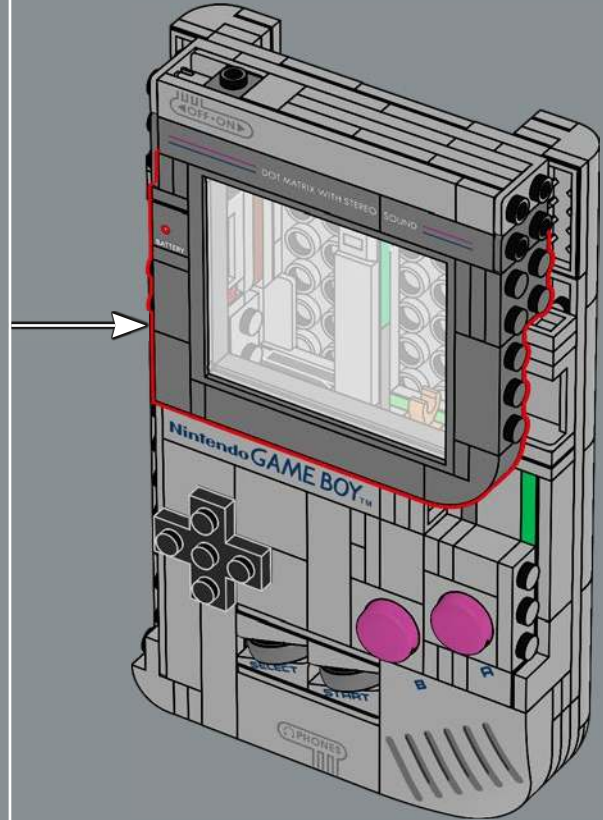

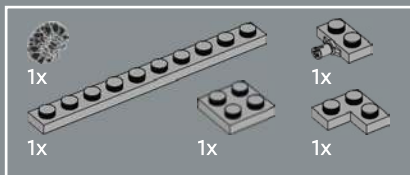

135

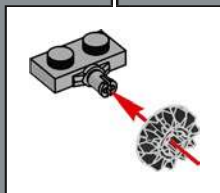
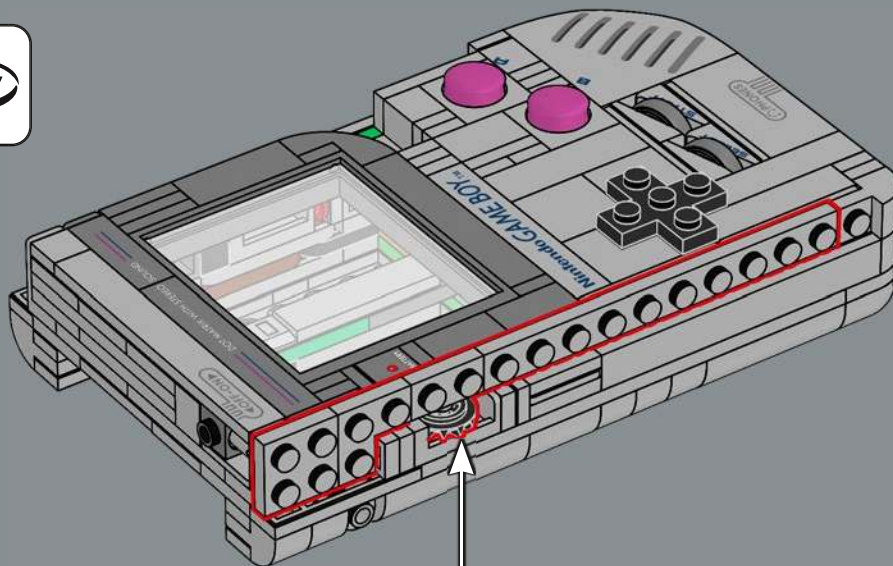

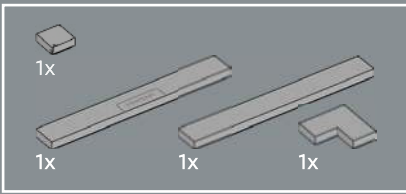

136

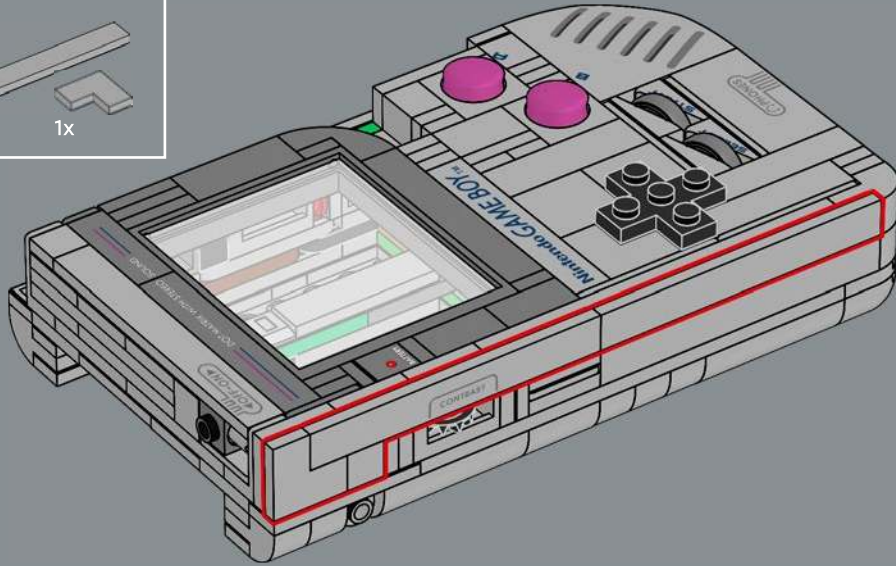

137

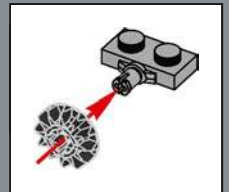
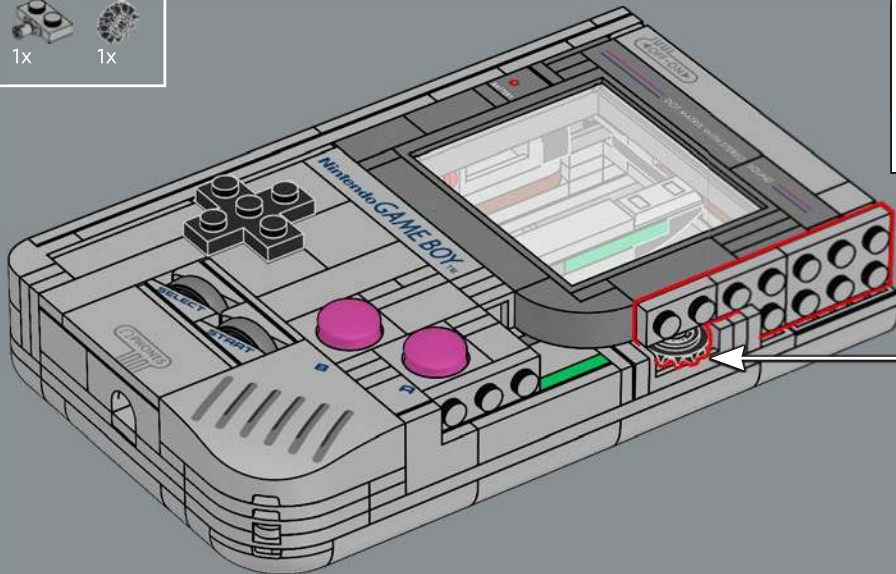

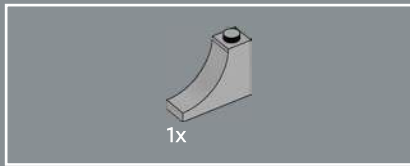

138

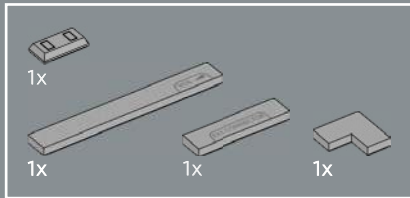
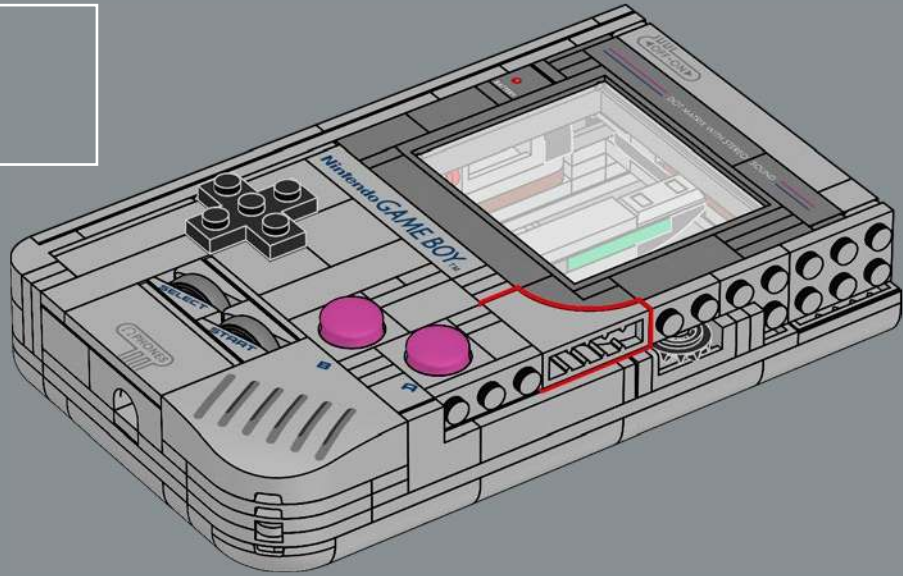

139

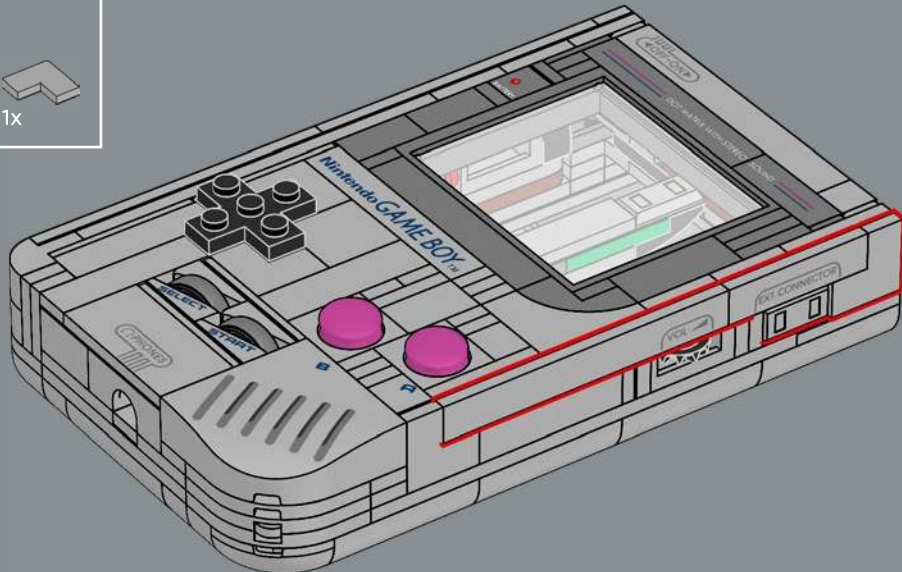

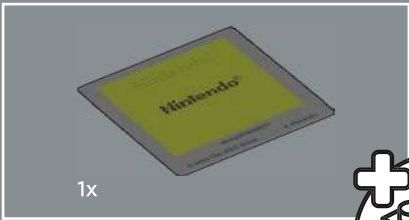

140

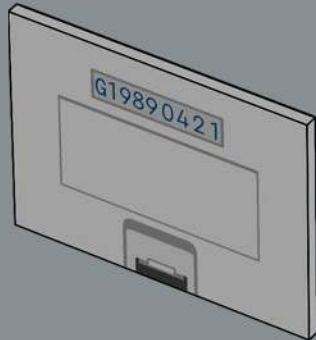
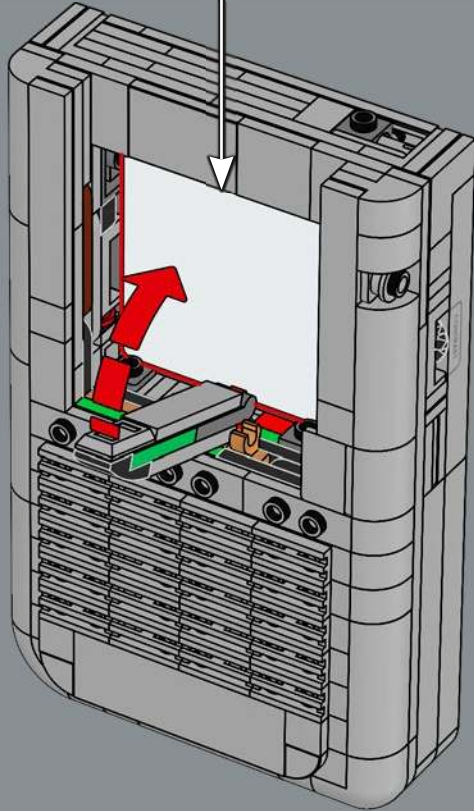
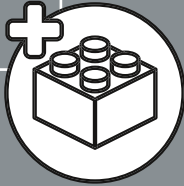

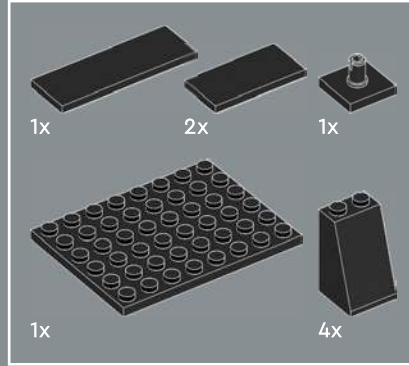
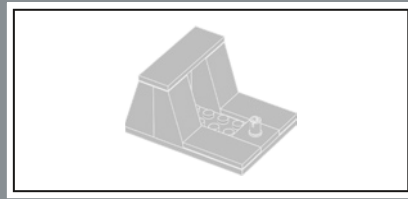

1

1

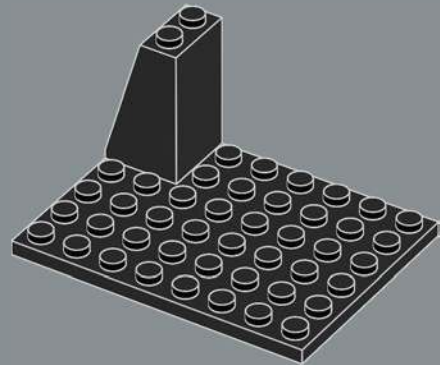

2

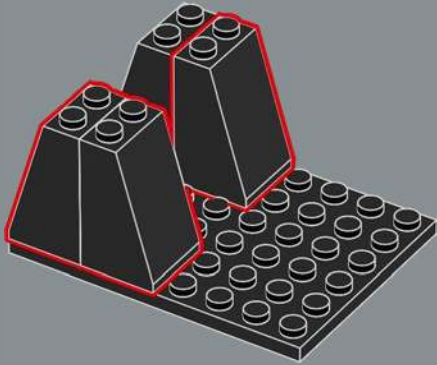

3

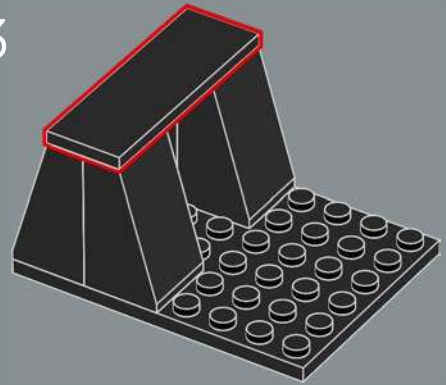

4

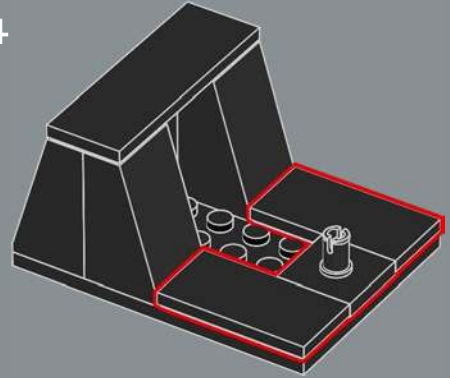

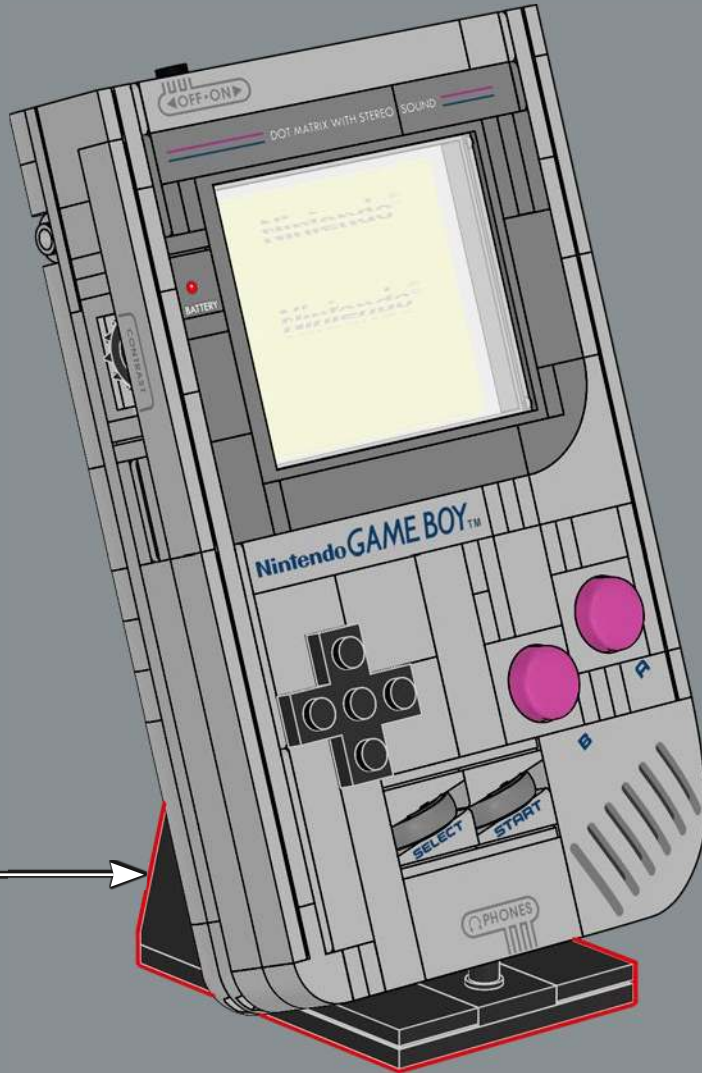

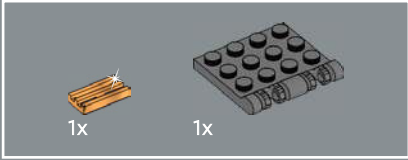

1

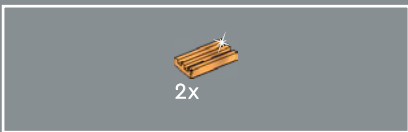

2

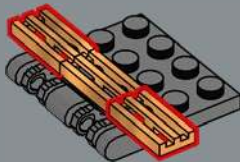

3

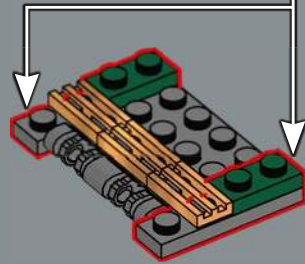
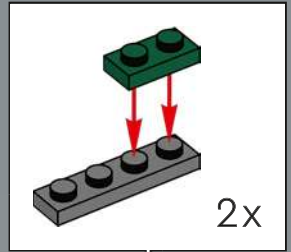

4

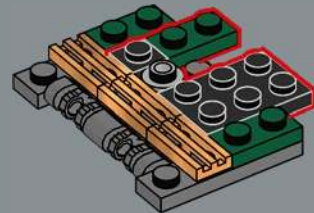

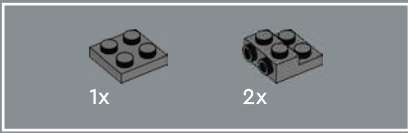

5

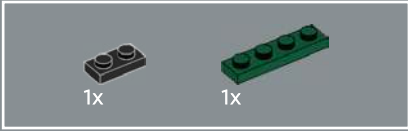
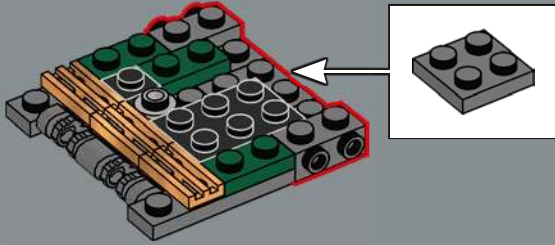

6

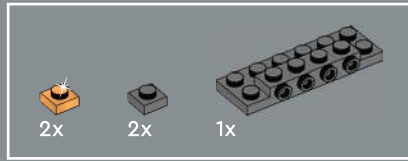
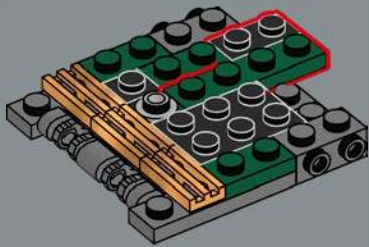

7

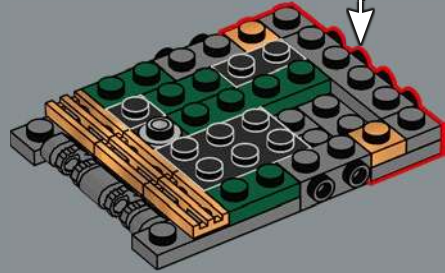
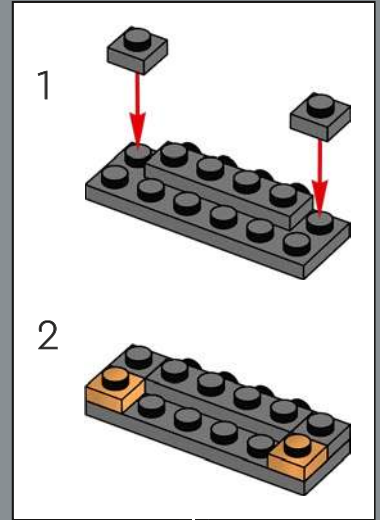

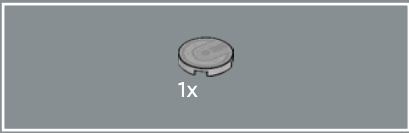

8

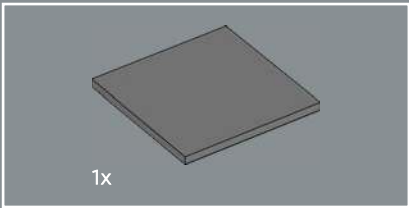
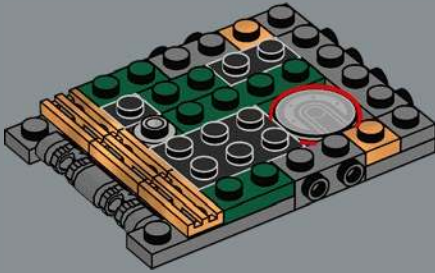

9



10

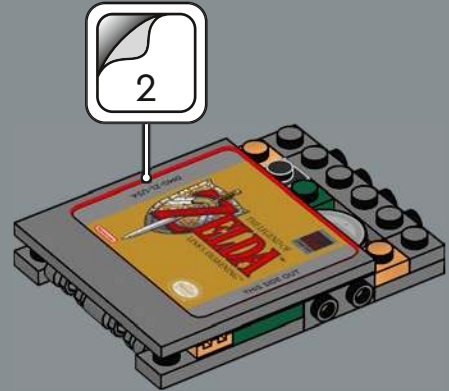

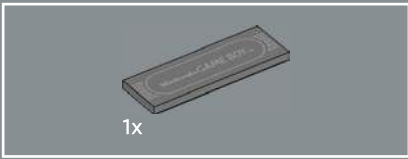

11

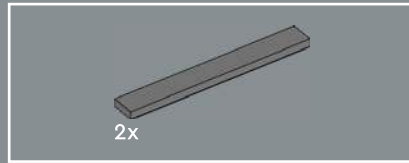

12

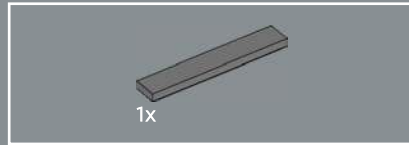

13

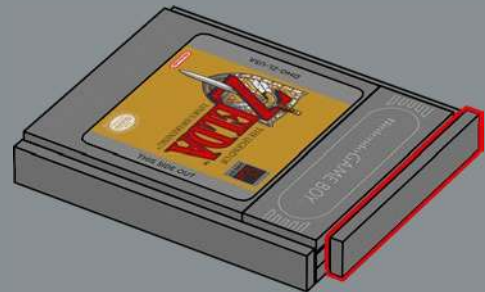

14

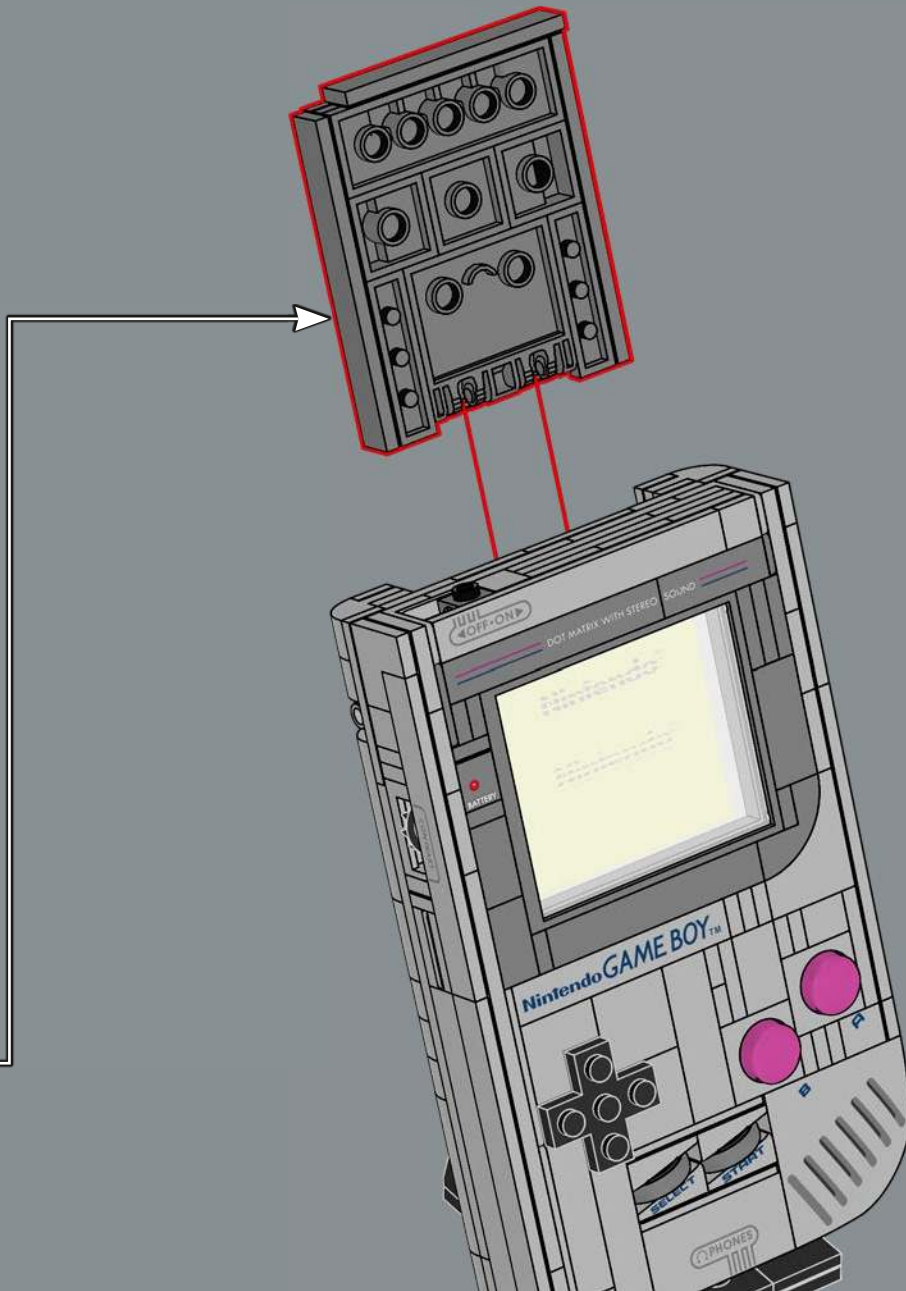

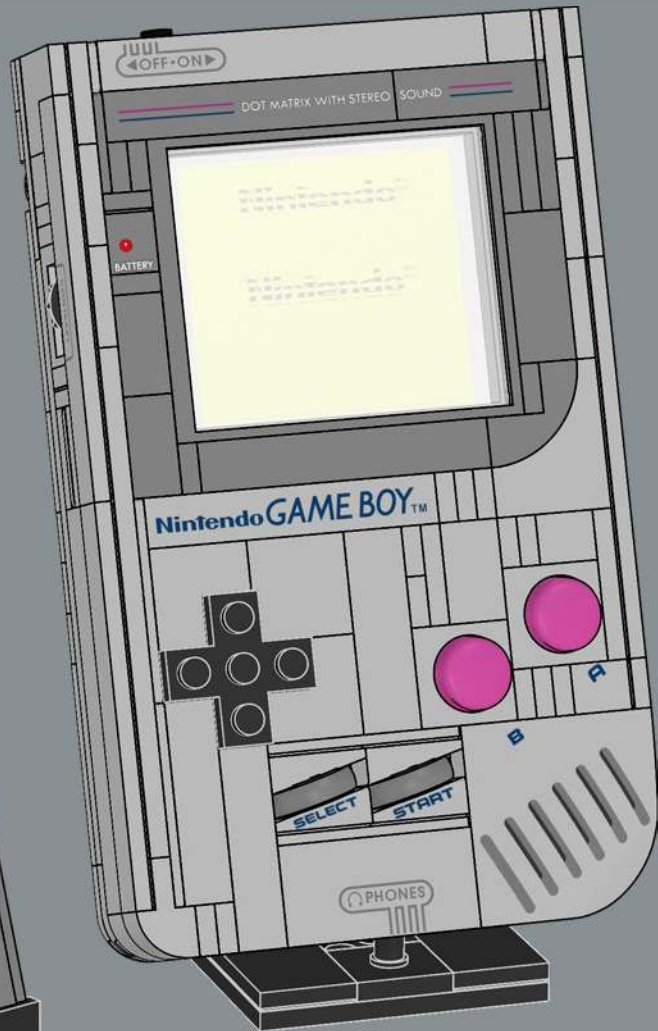

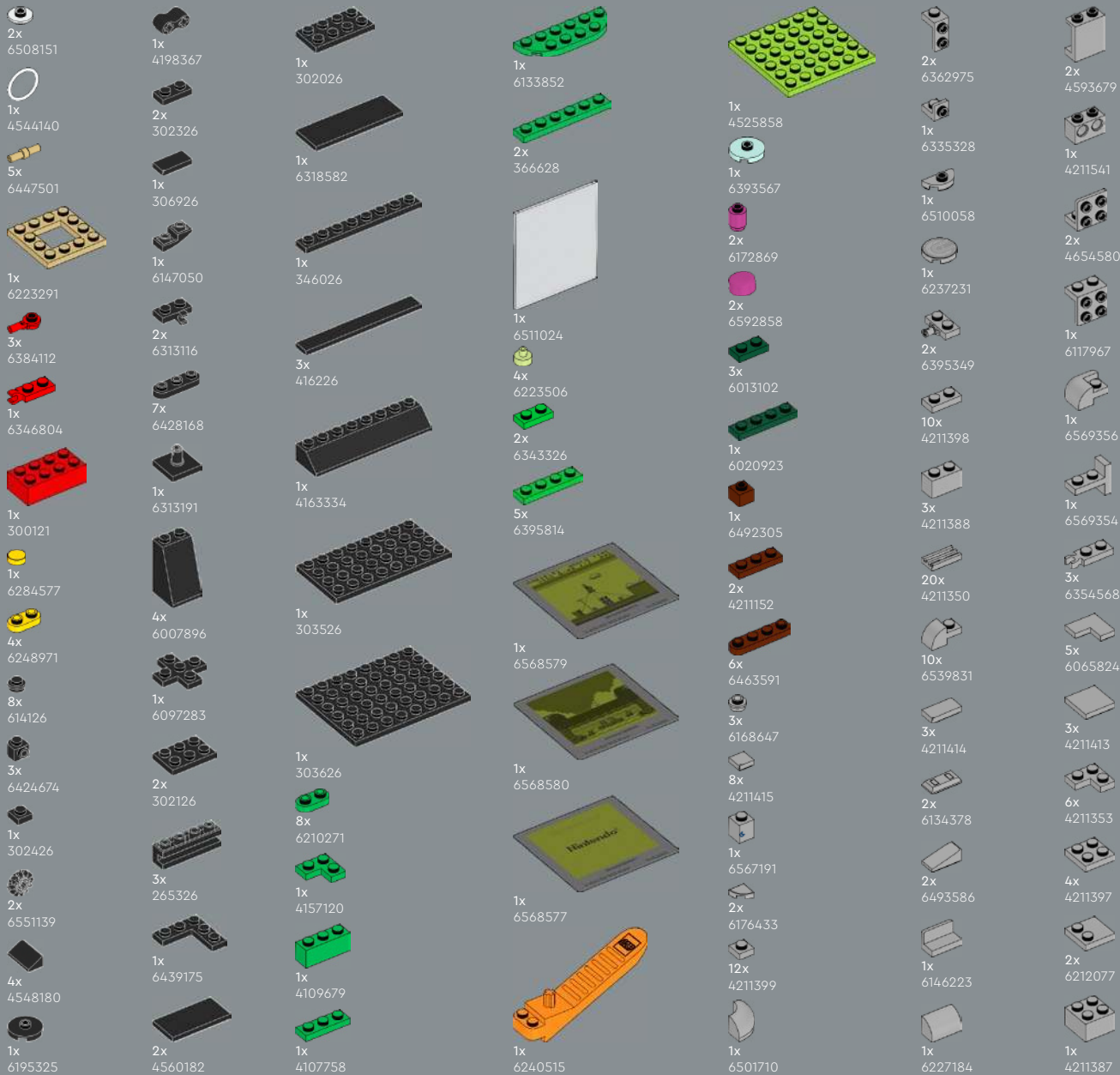

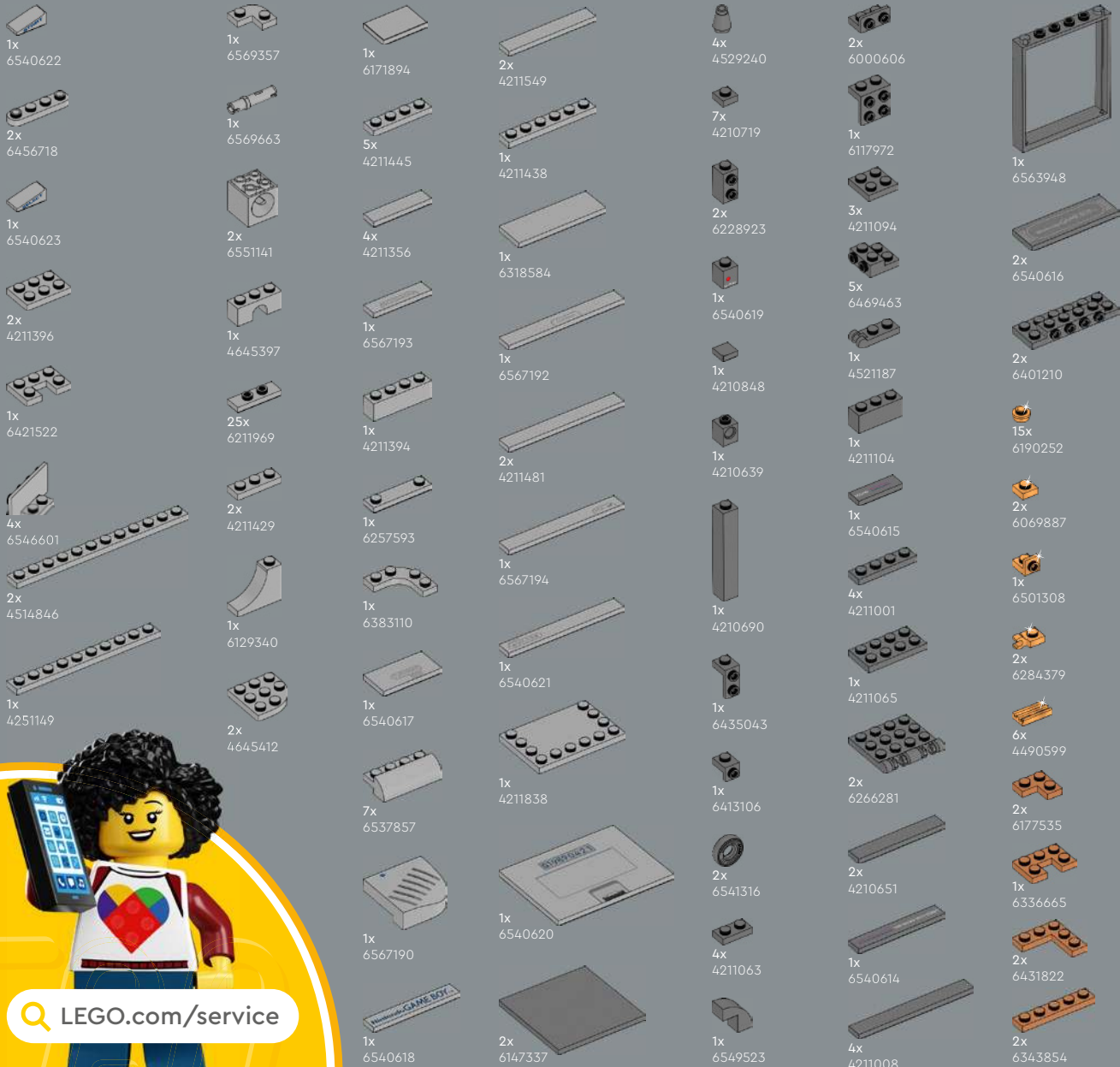

 [LEGO.com/service](https://www.LEGO.com/service)



YOU COULD WIN

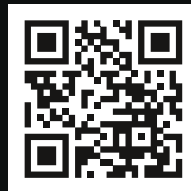

YOU COULD WIN

Your feedback will help shape the future development of this product series.

Visit:

DU KÖNNTST GEWINNEN

Dein Feedback trägt zur Weiterentwicklung dieser Produktreihe bei.

Geh auf:

VOUS POURRIEZ GAGNER

Vos commentaires nous aideront à concevoir les futurs produits de cette gamme.

Visitez :

POTRESTI VINCERE TU

La tua opinione ci aiuterà a migliorare la creazione futura di questa linea di prodotti.

Visita:

PUEDES GANAR

Tu opinión contribuirá al futuro de esta serie de productos.

Visita:

轻松获奖

您的反馈将有助于我们在今后改进本产品系列。

请访问:

LEGO.com/productfeedback

You also have the chance to win a LEGO® set.

Terms and conditions apply.*

Außerdem hast du die Chance, ein LEGO® Set zu gewinnen.

Es gelten die Teilnahmebedingungen.*

Vous pourriez également gagner un ensemble LEGO®.

Des conditions s'appliquent.*

Hai anche la possibilità di vincere un set LEGO®.

Termini e condizioni sono applicabili.*

También tienes la oportunidad de ganar un set LEGO®.

Aplican términos y condiciones.*

您还有机会赢取乐高®套装。

条款和条件适用。*

*LEGO.com/productfeedback-terms

GAME BOY™



LEGO, the LEGO logo and the Brick and Knob configurations are trademarks and/or copyrights of the LEGO Group.
©2025 The LEGO Group.

© Nintendo

 6634362