

BRAUN

MultiQuick 3



Type 4192

型号 4192

手持式搅拌机

Register your product

www.braunhousehold.com/register

MQ 3000 Smoothie+
MQ 3025 Spaghetti

English 6

中文 9

De'Longhi Braun Household GmbH
Carl-Ulrich-Straße 4
63263 Neu-Isenburg/Germany

5722112514/01.17 MQ 3000-3025 CN
GB/China



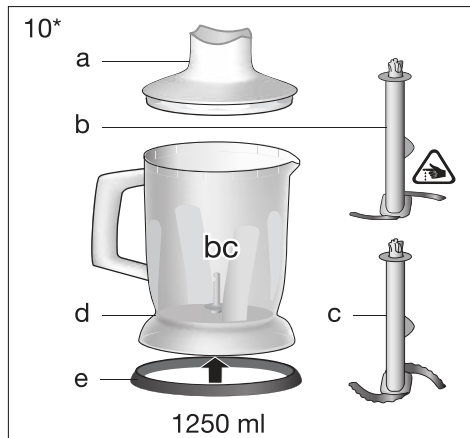
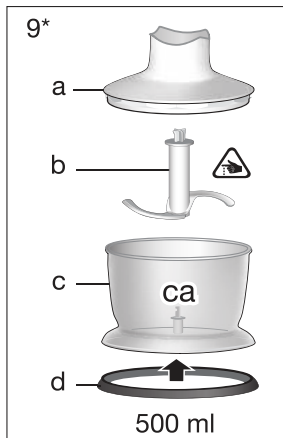
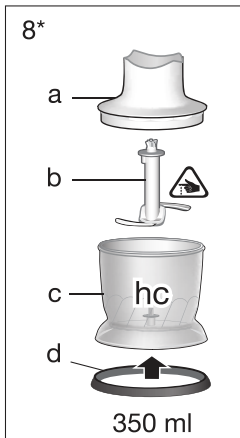
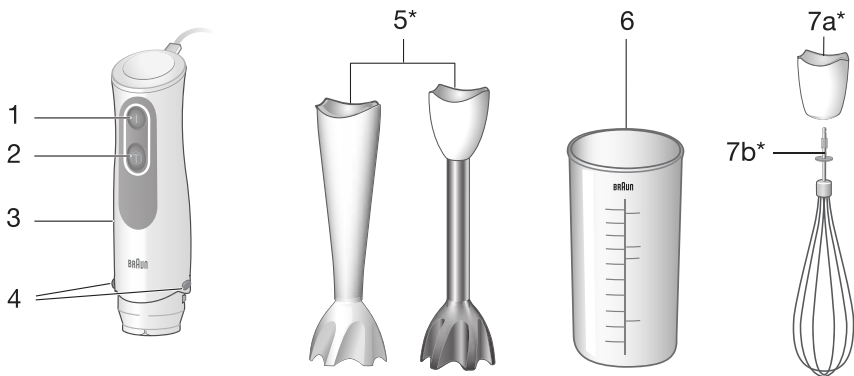

*certain models only *部分机型适用

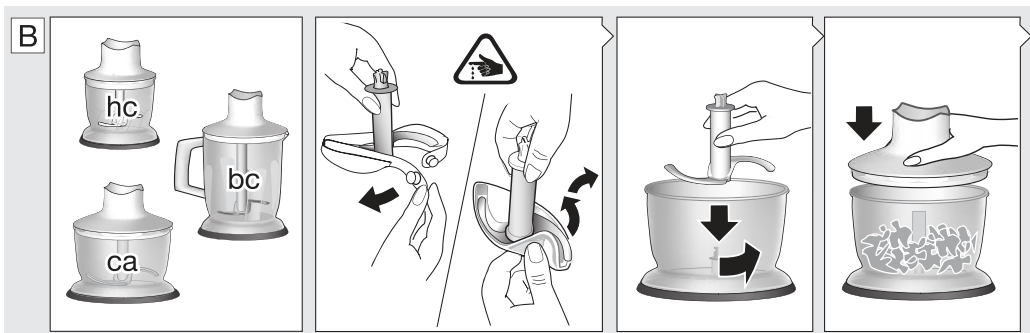
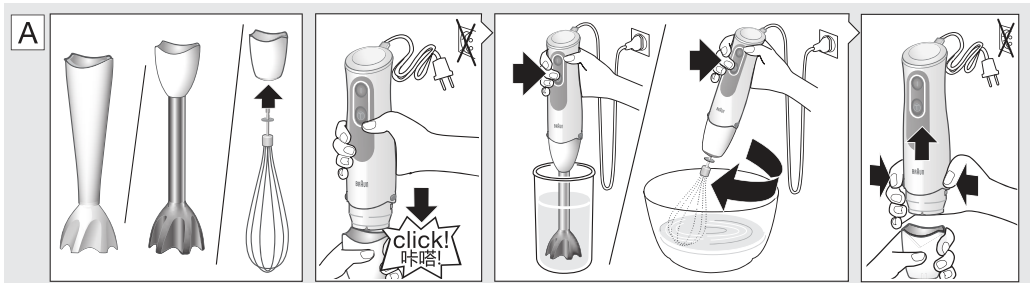

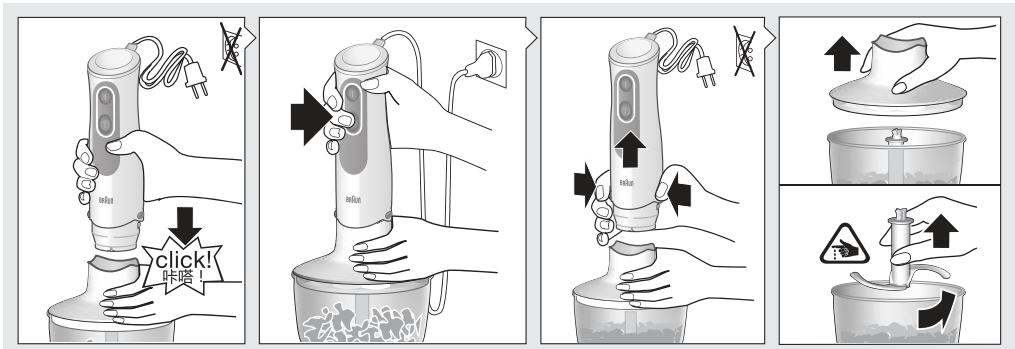

料理指南B		牛肉	帕尔马干酪 Parmesan	西芹	坚果	胡桃	洋葱	大蒜	胡萝卜	辣椒	香蕉、草莓
		1cm	1cm								
	最大食物料理量 max.	100g	100g	10g	100g	80g	50g	7	80g	90g+	X
	速度档位 speed	II			I 5 s + 5 s	I 5 s + 5 s	I			II	
	处理时间/秒 ⌚ sec.	10	20	5	I 5 s + II 5 s	I 5 s + II 5 s	5	5	10	45	
	最大食物料理量 max.	300g	200g	30g	350g	300g	200g	20	200g		X X
	速度档位 speed	II			I 30 s + 5 s	I	I				
	处理时间/秒 ⌚ sec.	15-30	30	20	I 30 s + II 5 s	I 25	10x1	5	15		
	最大食物料理量 max.	400g	200g	30g	400g	350g	250g	30	250g		150 g + 700 ml
	速度档位 speed	II			I 15 s + 5 s	I 15 s + 10 s	I			X	
	处理时间/秒 ⌚ sec.	30	20-30	15	I 15 s + II 5 s	I 15 s + II 10 s	15x1	10	15		II 60 + 15

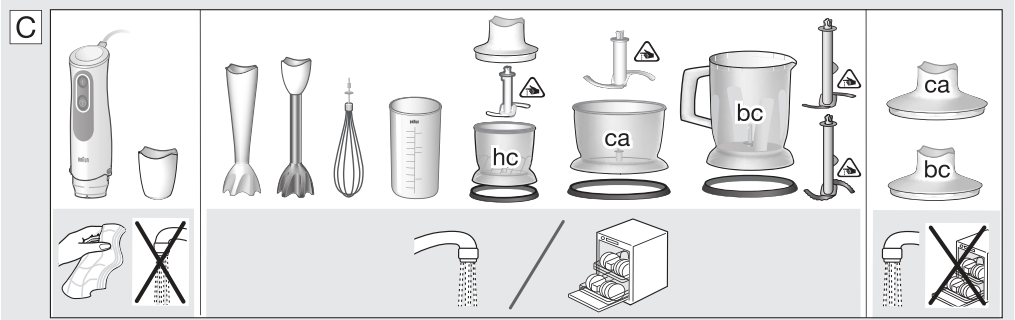

English

Our products are engineered to meet the highest standards of quality, functionality and design. We hope you thoroughly enjoy your new Braun appliance.

Before use

Please read instructions carefully and completely before using the appliance.

Caution

-  The blades are very sharp! To avoid injuries, please handle blades with utmost care.
- Care shall be taken when handling the sharp cutting blades, emptying the bowl and during cleaning.
- This appliance can be used by persons with reduced physical, sensory or mental capabilities or lack of experience and knowledge if they have been given supervision or instruction concerning use of the appliance in a safe way and if they understand the hazards involved.
- Children shall not play with the appliance.
- This appliance shall not be used by children.
- Children shall be kept away from the appliance and its mains cord.
- Always unplug or switch off the appliance when it is left unattended and before assembling, disassembling, cleaning and storing.
- If the supply cord is damaged, it must be replaced by the manufacturer, its service agent or similarly qualified persons in order to avoid a hazard.
- Before plugging into a socket, check whether your voltage corresponds with the voltage printed on the bottom of the appliance.
- This appliance is designed for household use only and for processing normal household quantities.

- Do not use any part in the microwave.
- Please clean all parts before first use or as required, following the instructions in the Care and Cleaning section.

Parts and Accessories

- On switch: speed «I»
- On switch: speed «II»
- Motor part
- EasyClick Release buttons
- Blender shaft
- Beaker
- Whisk accessory
 - Gearbox
 - Whisk
- 350 ml chopper accessory «hc»
 - Lid
 - Chopping blade
 - Chopper bowl
 - Anti-slip rubber ring
- 500 ml chopper accessory «ca»
 - Lid (with gear)
 - Chopping blade
 - Chopper bowl
 - Anti-slip rubber ring
- 1250 ml chopper accessory «bc»
 - Lid (with gear)
 - Chopping blade
 - Ice blade
 - Chopper bowl
 - Anti-slip rubber ring

How to Use the Appliance

Blending Shaft (A)

The hand blender is perfectly suited for preparing dips, sauces, salad dressings, soups, baby food, as well as drinks, smoothies and milkshakes. For best results, use the highest speed.

Assembly and Operation

- Attach the blending shaft (5) to the motor part until it clicks.
- Place the blending shaft into the mixture to be blended. Then switch the appliance on.
- Blend ingredients to the desired consistency using a gentle up-and-down motion.
- After use, unplug the hand blender and press the release buttons (4) to detach the blending shaft.

Caution

- If using the appliance to purée hot food in a saucepan or pot, remove the saucepan or pot

from the heat source and ensure the liquid is not boiling. Allow hot food to cool slightly to avoid risk of scalding.

- Do not let the hand blender sit in a hot pan on the cooktop when not in use.

Recipe Example: Mayonnaise

250 g oil (e.g. sunflower oil)

1 egg and 1 extra egg yolk

1–2 tbsp. vinegar

Salt and pepper to taste

- Place all ingredients (at room temperature) into the beaker in the order as above.
- Place the hand blender at the bottom of the beaker. Blend at maximum speed until the oil starts emulsifying.
- With the hand blender still running, slowly raise the shaft to the top of the mixture and back down to incorporate the rest of the oil.

NOTE: Processing time: approx. 1 minute for salads and up to 2 minutes for a thicker mayonnaise (e.g. for dip).

Whisk Accessory (A)

Use the whisk only for whipping cream, beating egg whites, making sponge cakes and ready-mix desserts.

Assembly and Operation

- Attach the whisk (7b) to the gearbox (7a).
- Align the motor part with the assembled whisk attachment and push the pieces together until they click.
- After use, unplug and press the release buttons to detach the motor part. Then pull the whisk out of the gearbox.

Tips for Best Results

- Move the whisk clockwise while holding it at a slight incline.
- To prevent splattering, start with speed «I» and use the whisk attachment in deep containers or pans.
- Place the whisk in a bowl and only then switch the appliance on.
- Always ensure the whisk and mixing bowl are completely clean and free of fat before whisking egg whites. Only whip up to 4 egg whites.

Recipe Example: Whipped Cream

400 ml chilled cream (min. 30% fat content, 4 - 8 °C)

- Only use speed «I» to operate the whisk
- Always use fresh chilled cream to achieve greater and more stable volume when whisking.

Chopper Accessory (B)

The choppers (8/9/10) are perfectly suited for chopping meat, hard cheese, onions, herbs, garlic, vegetables, bread, crackers and nuts.

Use the «hc» chopper (8) for fine results.

Use the «ca» (9) and «bc» chopper (10) for larger quantities and for hard foods.

Furthermore, the «bc» chopper offers a variety of other applications like shakes, drinks, purées, batter or crushed ice.

Refer to the Processing Guide B for maximum quantities, recommended times and speeds.

Maximum operation time for the «hc» chopper: 2 minutes for large amounts of wet ingredients, 30 seconds for dry or hard ingredients or amounts < 100 g. Immediately stop processing when motor speed decreases and/or strong vibrations occur.

Before Use

- Pre-cut foods into small pieces for easier chopping.
- Remove any bones, tendons and gristle from meat to help prevent damage to the blades.
- Make sure the anti-slip rubber ring (8d/9d/10e) is attached to the bottom of the chopper bowl.

Assembly and Operation

- Carefully remove the plastic cover from the blade.
- The blades (8b/9b/10b/10c) are very sharp! Always hold them by the upper plastic part and handle them carefully.
- Place the blade on the center pin of the chopper bowl (8c/9c/10d). Press it down and give it a turn so that it locks into place.
- Fill the chopper with food and put on the lid (8a/9a/10a).
- For ice crushing, fill up to 7 ice cubes into the chopper bowl (10d) and use the special ice blade (10c).
- Align the chopper with the motor part (3) and click together.
- To operate the chopper, switch on the appliance. During processing, hold the motor part with one hand and the chopper bowl with the other.
- Always chop harder foods (e.g. parmesan cheese) at full speed.
- When chopping is complete, unplug and press the release buttons (4) to detach the motor part.
- Lift the lid up. Carefully take out the blade before pouring out the contents of the bowl. To remove the blade, slightly turn it then pull it off.

Caution

- Do not use the chopper accessories (8/9/10) to process extremely hard foods, such as unshelled nuts, coffee beans, grains, or hard spices e.g. nutmeg. Processing these foods could damage the blades.
- Only the «bc» chopper accessory with the special ice blade is allowed to crush ice cubes.
- Never place the chopper bowl in the microwave oven.

«bc» Recipe Example: Pancake Batter

375 ml milk

250 g plain flour

2 eggs

- Pour milk into the «bc» bowl, then add flour and finally the eggs.
- Using speed «I», mix the batter until smooth.

«hc» Recipe example: Honey-Prunes (as a pancake stuffing or spread):

50 g prunes

70 g creamy honey

10 ml water (vanilla-flavoured)

- Fill the «hc» chopper bowl with prunes and creamy honey.
- Chop 4 seconds at maximum speed
- Add 10 ml water (vanilla-flavoured).
- Resume chopping for another 1,5 seconds.

Care and Cleaning (C)

- Unplug hand blender before cleaning.
- Do not immerse the motor part (3) or gearbox (7a) in water or any other liquid. Clean with a damp cloth only.
- The lid (9a/10a) can be rinsed under running water. Do not immerse in water, nor place in a dishwasher.
- All other parts can be cleaned in a dishwasher. Do not use abrasive cleaners that could scratch the surface.
- You may remove the anti-slip rubber rings from the bottom of the bowls for an extra thorough clean.
- When processing foods with high pigment content (e.g. carrots), the accessories may become discolored. Wipe these parts with vegetable oil before cleaning them.

Both the design specifications and these user instructions are subject to change without notice.

Do not dispose of the product in household waste at the end of its useful life.



Materials and accessories coming into contact with food conform to EEC regulation 1935/2004.



本产品经过精心设计，功能完备、质量优异，满足高标准要求。希望您喜欢这款新型的博朗产品。

使用本产品前请仔细阅读使用说明书。

注意

-  刀片非常锋利！操作时必须格外小心，避免受伤。
- 当取出或使用切割刀片，排空混料盆，清洗期间都应该小心。
- 本产品不适宜身体或精神上有缺陷者或缺乏相关使用经验和知识的人群使用，除非有专人负责照看或指导以保证他们的安全。
- 请勿让儿童把玩本产品。
- 本产品不适宜儿童使用。
- 请勿让儿童接触本产品及其电源线。
- 无人看管时或安装、拆卸、清洗及收藏本产品时，请拔掉插头。
- 电源线损坏时，为了避免危险，请务必由制造商、代理商或相关专业人员更换。
- 通电前，请确保电源电压与产品底部标注的电压一致。
- 本产品仅限于家用，适合处理普通家庭量的食物。
- 本机及其配件不可用微波炉加热。
- 切勿将电机部件浸入水中。
- 初次使用前请清洗所有部件，之后按需要清洗。具体清洗方法参照《维护和清洗》部分。

组件和附件

- 1 开关按钮：速度“I”档
- 2 开关按钮：速度“II”档
- 3 电机部件
- 4 快捷松解按钮
- 5 搅拌轴
- 6 搅拌杯
- 7 打蛋器附件
 - a 打蛋器齿轮箱
 - b 打蛋器
- 8 350毫升切碎器《hc》

- a 盖罩
 - b 切碎刀
 - c 切碎碗
 - d 防滑垫
- 9 500毫升切碎器《ca》

- a 盖罩（带齿轮）
 - b 切碎刀
 - c 切碎碗
 - d 防滑垫
- 10 1250毫升切碎器《bc》
- a 盖罩（带齿轮）
 - b 切碎刀
 - c 碎冰刀
 - d 切碎碗
 - e 防滑垫

MQ3025 Spaghetti不包含9、10附件
MQ3000 Smoothie+不包含7、8、9、10附件

如何使用手持式搅拌机

搅拌轴（参见图示A）

手持式搅拌机十分适用于制备蘸酱、调味汁、色拉酱、汤、婴儿食品以及饮品、冰沙和奶昔。
使用最高速可实现最佳处理效果。

组装和操作

- 将搅拌轴(5)和电机部件(3)连接直至锁紧。
- 将手持式搅拌机放入待搅拌食物中，启动搅拌机。
- 搅拌过程中轻轻地上下移动直至食物达到理想的均匀度。
- 使用完毕后，拔掉电源插头，按下松解按钮（4），卸下搅拌轴。

注意

- 如用手持式搅拌机在平底锅或其他锅中将高温食物捣成泥，请先将锅从热源处移开，确保液体不再沸腾。高温食物适当冷却后再处理，以免烫伤。
- 不用搅拌机时，请勿将其放在炉灶台上的热锅内。

食谱实例：蛋黄酱

250克食用油（例如：葵花籽油）

一个鸡蛋加一个蛋黄

一到二汤匙醋

盐和胡椒粉调味

· 将所有食材（常温）按照上述顺序放入搅拌杯(6)。

· 将手持式搅拌机置于搅拌杯(6)底部。以最高速进行搅拌，直至食用油开始乳化。

· 搅拌机保持运转状态，慢慢上下移动搅拌棒，直至剩下的食用油充分混合。

注意：色拉的处理时间为大约1分钟，而较浓的蛋黄酱则至多需要2分钟。

打蛋器配件(参见图示A)

打蛋器仅适用于打发奶油、打散蛋白以及搅拌海绵蛋糕面糊与预拌好的甜点。

组装和操作

· 连接打蛋器（7b）和齿轮箱（7a）。

· 连接电机部件(3)与组装好的打蛋配件直至锁紧。

· 使用完毕后，拔掉电源插头，按下松解按钮(4)，卸下电机部件。然后将打蛋器从齿轮箱中拔出。

为实现最佳处理效果

· 略微倾斜打蛋器，以顺时针方向搅动。

· 为了避免液体溅出，开始时请使用速度“1”档，并在较深的容器或平底锅中使用打蛋器配件。

· 将打蛋器放入搅拌杯后再启动搅拌机。

· 打散蛋白前，请确保打蛋器和搅拌杯完全干净且不带油脂。每次最多打散4个蛋白。

食谱实例：打发奶油

400毫升冷冻奶油（脂肪含量最低为30%，4-8℃）

· 使用打蛋器时速度只能设定在“1”档。

· 请使用新鲜的冷冻奶油，才能使打发出来的量更多更均匀。

切碎器配件(参见图示B)

切碎器（8/9/10）十分适用于切碎肉类、奶酪、洋葱、药草、蒜、蔬菜、面包、饼干和坚果等食物。

使用«hc»切碎器（8）可实现更细腻的处理效果。

使用«ca»切碎器(9)和«bc»切碎器(10)来处理量比较大或比较坚硬的食物。

此外，«bc»切碎器(10)还可用于制作奶昔、饮品、浓汤等食物以及捣碎冰块。

如欲了解最大处理量以及处理时间和速度建议，请参阅《料理指南B》。

«hc»切碎器(8)的最长运作时间：

量大的湿材料：2分钟

干燥或坚硬的材料或量小于100克的材料：30秒钟

电机速度减小和/或出现强烈震动时请马上停止处理。

使用切碎器前

· 请预先将食物切成小块，方便切碎器处理。

· 去掉肉类中的骨头、肌腱以及软骨，以免损坏刀片。

· 确保防滑垫（8d/9d/10e）始终放置在切碎碗底部。

组装和操作

· 请小心取下刀片上的塑料套。

· 刀片(8b/9b/10b/10c)非常锋利！取用时始终握住刀片上部的塑料部分，小心使用。

· 将刀片放置在切碎碗（8c/9c/10d）的中心轴上，轻轻旋转将其锁紧。

· 将食物放入切碎碗中，盖上盖罩(8a/9a/10a)。

· 碎冰时，最多可以往切碎碗（10d）里装7块冰块，使用特殊的碎冰刀（10c）进行处理。

· 连接切碎器和电机部件（3）直至锁紧。

· 使用时，启动搅拌机。处理过程中，一手握着电机部件，另一只手固定切碎碗。

- 请使用全速处理比较坚硬的食物(例如, 帕尔马干酪)。
- 使用完毕后, 拔掉电源插头, 按下松懈按钮(4), 卸下电机部件。
- 打开盖罩, 小心地旋松刀片将其取出, 然后将碗中的食物倒出来。

注意

- 请勿使用切碎器(8/9/10)处理未脱壳的坚果、咖啡豆、谷物和肉豆蔻等十分坚硬的食物。处理这类食物可能会损坏刀片。
- 只有带有特殊碎冰刀片10C的切碎器((bc))才能用来碎冰。
- 请勿将切碎碗放入微波炉加热。

《bc》食谱实例: 煎饼面粉

375毫升牛奶
250克纯面粉
2个鸡蛋

- 先把牛奶倒入((bc))切碎碗中, 然后加入面粉, 最后加入鸡蛋。
- 使用速度“II”档, 将面糊混合至均匀。

《hc》食谱实例: 蜂蜜西梅酱

(用作煎饼馅或外层装饰物):

50克去核西梅干
70克奶油蜂蜜
10毫升水

- 把去核西梅干和奶油蜂蜜放入((hc))切碎碗中。
- 用最高速II档搅拌4秒。
- 加入10毫升水。
- 接着搅拌1,5秒。

维护和清洗(参见图示C)

- 清洗前拔掉电源插头
- 仅可使用湿布清洁电机部件(3)或齿轮箱(7a), 切勿浸于水或其他液体中。
- 盖罩(9a/10a)可以在流水下冲洗, 但不可浸泡在水中, 也不可以用洗碗机清洗。
- 其他所有零件都可用洗碗机清洗。不要使用会刮花零件表面的摩擦性清洁物清洗。

- 你可以将切碎碗底部的防滑垫拿出来彻底清洁。

- 处理色素含量高的食材时(比如, 胡萝卜), 配件可能会染色。可用植物油擦拭后再进行清洗。

设计规格和使用说明书如有修改, 恕不另行通知。

请勿在本产品达到使用寿命后与普通垃圾一起扔掉。



保修

我们为产品提供为期两年的保修, 保修期从购买日开始计算。

在保修期内对于产品因材料或生产过程引起的各种瑕疵, 我们会视情况更换零件或整个产品。

申请保修必须将本产品 and 能够证明购买日期的证据(购货发票)一起交给授权的Braun维修站, 本产品附有一张授权的维修站名单。

请确认已将购货发票放置在安全的地方。

上述保修不包括以下内容:

- 由于使用不当而造成的产品损坏(如: 使用错误的电流、电压, 将产品插入不合适的插座, 或者人为损坏等)。
- 正常使用引起的产品老化、磨损, 但对产品的使用功能及价值影响不大。
- 按行业惯例定义的易损、易耗件。
- 如果产品经过未经授权的人员的修理, 或产品使用了非本公司(Braun)的零件, 保修期即终止。
- 非家庭使用(如工业、商业用)引起的损坏。
- 在保修期内提供的服务并不影响保修期按时结束, 保修期中替换的零件或整机的保修服务与本产品的保修期同时终止。
- 除非确有法律规定, 本公司不对其他任何要求负责。同供货商的销售合同中规定的各项权利不受此保修的影响。

如果需要保修或维修, 请与当地的维修站, 或就近的维修站联系。

客服热线: 400 827 1668



名称和产品中有害物质的含量

Name and content of hazardous substances in products

组件 名称 Components Name	有害物质 Hazardous substances					
	铅 Lead (Pb)	汞 Mercury (Hg)	镉 Cadmium (Cd)	六价铬 Hexavalent Chromium (Cr (VI))	多溴联苯 Polybrominated biphenyls (PBB)	多溴二苯醚 Polybrominated diphenyl ethers (PBDE)
印刷电路板 组装 Printed Circuit Board Assembly	X	○	○	○	○	○

本表格依据SJ/T 11364 的规定编制。This table is prepared in accordance with the provisions of SJ/T 11364.

○:表示该有害物质在该部件所有均质材料中的含量均在GB/T 26572规定的限量要求以下。

○: The content of such hazardous substance in all homogeneous material of such components is below the limit required by GB/T 26572.

X:表示该有害物质至少在该部件的某一均质材料中的含量超出GB/T 26572规定的限量要求。主要是由于受技术发展水平限制,暂时无法实现替代或减量化,但这部分零部件本身不直接与食物接触,正常使用条件下不会对使用者造成任何健康影响。我们的产品均通过食品安全检测,可安心使用。

X: The content of such hazardous substance in a certain homogeneous material of such components is beyond the limit required by GB/T 26572, **mainly due to the level of technical development situation, temporarily unable to achieve replacement or reduction. But this part of the component itself does not directly contact with food, it will not cause any health issue under normal conditions of use. All our products passed Food Safety Monitoring and can be used safely.**

