

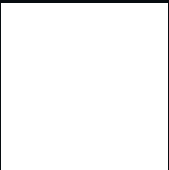

McLaren
FORMULA 1 TEAM



Booklet available in English on
Livret disponible en français sur
Folleto disponible en español en



McLAREN 2022





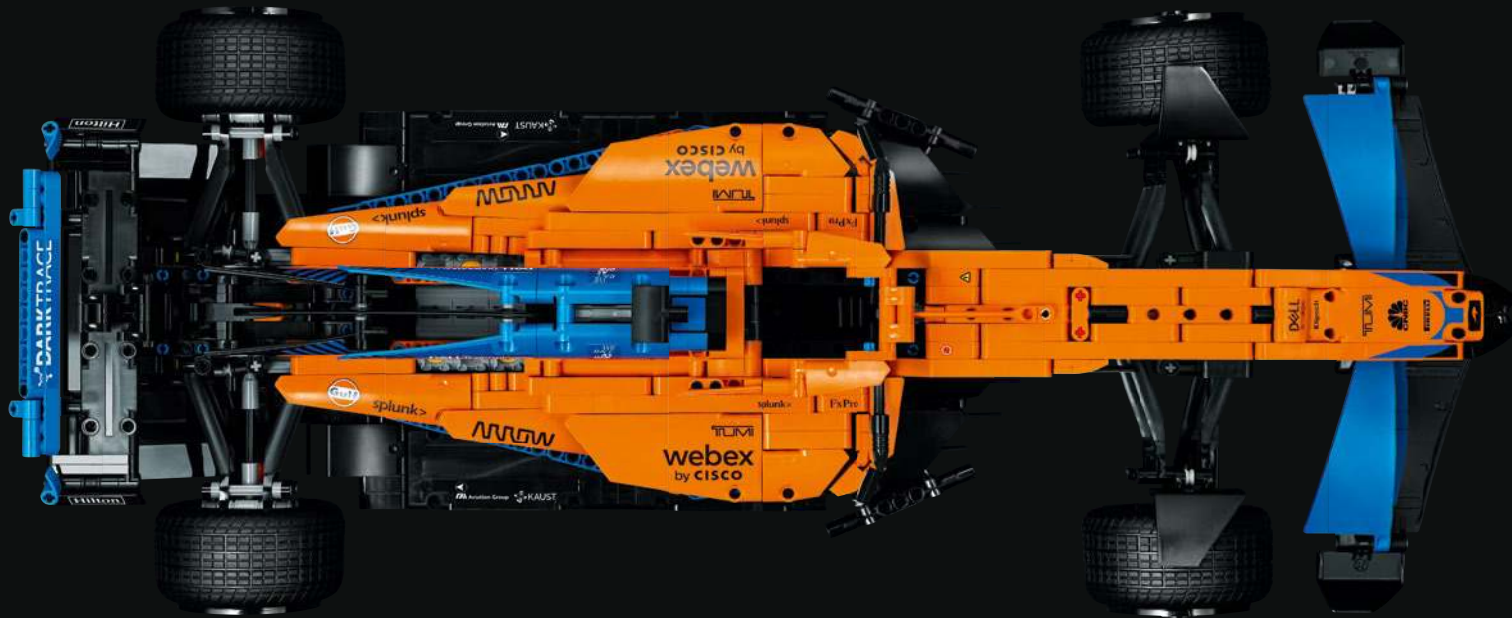

THE PASSION FOR PERFECTION **LA PASSION POUR LA PERFECTION** **PASIÓN POR LA PERFECCIÓN**

With over 180 race victories and 20 World Championships, McLaren Racing is one of the most successful names in the history of Formula 1. During five decades of racing, the team has become famous for its iconic vehicle designs and technical innovation.

Nothing symbolizes this more than the stunning McLaren F1 race car. Developed specifically for the 2022 season, it combines a smooth "organic" form with state-of-the-art technology. It provided the perfect challenge for the LEGO® Technic™ design team as they tried to recreate the McLaren 2022 Formula 1 car in Technic elements.

Avec plus de 180 courses et 20 championnats du monde remportés à son actif, McLaren Racing est l'un des plus grands noms de l'histoire de la Formule 1. Au cours de cinq décennies de course, l'écurie est devenue célèbre pour ses véhicules emblématiques et ses innovations techniques.

L'époustouflante voiture de course McLaren F1 en est la preuve. Produite tout spécialement pour la saison 2022, elle marie une forme lisse « organique » avec une technologie de pointe. Elle a posé un défi idéal pour l'équipe de conception LEGO® Technic™, chargée de recréer la voiture de Formule 1 McLaren 2022 en éléments Technic.

Con más de 180 victorias en carreras y 20 Campeonatos Mundiales, McLaren Racing es uno de los nombres más exitosos de la historia de la Fórmula 1. Durante cinco décadas de competencias, la escudería ha alcanzado la fama por el diseño característico de sus vehículos y sus innovaciones técnicas.

Nada lo representa mejor que el impresionante monoplaza McLaren F1. Desarrollado específicamente para la temporada 2022, combina una fluida forma "orgánica" con la tecnología más avanzada. Era un desafío perfecto para el equipo de diseño de LEGO® Technic™, que se propuso recrear el Fórmula 1 McLaren para 2022 con elementos Technic™.



2021 Bahrain Grand Prix

CREATING A NEW FORMULA LA CRÉATION D'UNE NOUVELLE FORMULE UNA NUEVA FÓRMULA

The new regulations for the 2022 season presented McLaren Racing's design team with the exciting challenge of developing an entirely new race car from scratch.

With a format that looks to encourage more competitive racing, the team improved the car's aerodynamic wake to allow for closer contests with more thrilling maneuvers. The new, enhanced performance also demanded the development of completely new braking and suspension systems.

"Developing a new Formula 1 car is like assembling a puzzle. We have built significant momentum over recent seasons, and it's important that we continue our upward trajectory as we enter new, uncharted territory. The team has worked hard to embrace the new formula, and we are excited to go racing in a new chapter of the sport."

Andreas Seidl, Team Principal, McLaren F1

Après l'introduction d'une nouvelle réglementation pour la saison 2022, l'équipe de conception de McLaren Racing a dû relever le défi de développer de toutes pièces une voiture de course entièrement nouvelle.

L'équipe a amélioré le sillage aérodynamique de la voiture pour permettre des luttes plus serrées et des manœuvres plus excitantes et ainsi donner lieu à des courses plus compétitives. Les nouvelles performances accrues ont également nécessité l'élaboration de systèmes de freinage et de suspension entièrement nouveaux.

« Développer une nouvelle voiture de Formule 1, c'est comme assembler un casse-tête. Nous avons progressé considérablement au cours des dernières saisons, et il est important que nous poursuivions notre trajectoire ascendante alors que nous nous aventurons en terrain inconnu. L'équipe a travaillé dur pour adopter la nouvelle formule, et nous sommes impatients de participer à un nouveau chapitre du sport automobile. »
Andreas Seidl, Team Principal, McLaren F1

El reglamento para la temporada 2022 planteó al equipo de diseño de McLaren Racing el apasionante reto de desarrollar un auto de carreras completamente nuevo.

Con un formato que busca propiciar carreras más competitivas, el equipo mejoró la huella aerodinámica del auto para lograr competencias más reñidas con maniobras más emocionantes. El nuevo y mejorado desempeño exigió también el desarrollo de sistemas de frenado y suspensión desde cero.

"Desarrollar un nuevo monoplaza de Fórmula 1 es como armar un rompecabezas. Hemos tomado un gran impulso durante las últimas temporadas y es importante no abandonar esa trayectoria ascendente a medida que nos adentramos en territorio nuevo e inexplorado. El equipo ha trabajado duro para adoptar la nueva fórmula y nos entusiasma la idea de pisar el acelerador e iniciar un nuevo capítulo en este deporte".

Andreas Seidl, Team Principal, McLaren F1





**DEVELOPING A NEW FORMULA 1 RACING CAR IS LIKE
DEVELOPING AND ASSEMBLING A PUZZLE**
**DÉVELOPPER UNE NOUVELLE VOITURE DE FORMULE 1,
C'EST COMME ASSEMBLER UN CASSE-TÊTE**
**DESARROLLAR UN NUEVO MONOPLAZA DE
FÓRMULA 1 ES COMO ARMAR UN ROMPECABEZAS**

Andreas Seidl, Team Principal, McLaren F1



**LARS KROGH
JENSEN**
Designer/
Concepteur
LEGO® Technic™



FROM THE DESIGN TEAM UN MOT DE L'ÉQUIPE DE CONCEPTION IMPRESIONES DEL EQUIPO DE DISEÑO

The biggest challenge LEGO® designer Lars Krogh Jensen faced while recreating the LEGO Technic™ version of the McLaren Formula 1 car was the fact that the real race car was still under development. *"It was exciting following the process and seeing their car evolve, but of course, it also meant I was constantly having to make adjustments to our model."* The team started with a sketch build, which quickly revealed extra stability would be needed due to the model's 25.5 in. (65 cm) extended length. Capturing the smooth rounded lines of the car's design in rigid Technic elements was the next big test. But for Lars it was also about the features and functions: *"It wouldn't be a real Technic model without things like the working differential and steering."*

Le plus grand défi auquel le concepteur LEGO® Lars Krogh Jensen a été confronté en travaillant sur la version LEGO Technic™ de la voiture de Formule 1 McLaren était le fait que la vraie voiture de course était toujours en cours de développement. *« C'était passionnant de suivre le processus et de voir leur voiture évoluer, mais bien sûr, cela signifiait aussi que je devais constamment faire des ajustements à notre modèle. »* L'équipe a commencé par un croquis, qui a rapidement révélé qu'il serait nécessaire d'augmenter la stabilité du modèle en raison de sa longueur (65 cm). L'épreuve suivante a été de reproduire les lignes arrondies et lisses de la silhouette de la voiture avec des éléments Technic rigides. Mais selon Lars, il fallait aussi penser aux caractéristiques et aux fonctions : *« Ce ne serait pas un vrai modèle Technic sans des fonctionnalités comme un différentiel et une direction qui fonctionnent. »*

El mayor obstáculo que tuvo que superar el diseñador de LEGO® Lars Krogh Jensen al recrear la versión LEGO Technic™ del Fórmula 1 McLaren fue que el verdadero auto de carreras todavía estaba en desarrollo. *"Fue emocionante seguir el proceso y ver cómo evolucionaba su auto, pero, por supuesto, eso implicó también ajustar constantemente nuestra recreación".* El equipo partió de un borrador que pronto reveló una necesidad de mayor estabilidad por la gran longitud del modelo, de 65 cm. La siguiente gran prueba consistió en plasmar las suaves líneas curvadas del diseño del auto usando los rígidos elementos Technic™. Sin embargo, para Lars también eran fundamentales las características y funciones: *"No sería un verdadero modelo Technic™ sin mecanismos como el diferencial y la dirección".*



THE PERFECT PARTNERSHIP LE PARTENARIAT PARFAIT UNA ASOCIACIÓN PERFECTA

Frequent check-ins between the two design teams were vital to ensuring the final model captured both the look and spirit of the real 2022 McLaren Formula 1 race car. James Key, Executive Director, Technical at McLaren F1 was pleased with the flexibility and collaboration of the Technic designers – *"We began working on the next generation of racing car as soon as the blueprint is revealed. From there the process is almost continuous until the very last moment. We were delighted to have that agile working relationship with the Technic team. The final result looks fantastic."*

De fréquentes consultations entre les deux équipes de conception ont été essentielles pour garantir que le modèle final reflète à la fois l'aspect et l'esprit de la véritable voiture de Formule 1 McLaren 2022.

James Key, directeur général du service technique de McLaren F1, a grandement apprécié la flexibilité et la collaboration des concepteurs de Technic : *« Nous avons commencé à travailler sur la prochaine génération de voitures de course dès que le plan a été révélé. À partir de ce moment, le processus est continu presque jusqu'au tout dernier instant. Nous avons été ravis d'avoir une telle relation de travail avec l'équipe de Technic. Le résultat final est tout simplement fantastique. »*

Las frecuentes reuniones entre los dos equipos de diseño fueron esenciales para garantizar que el modelo final capturara tanto el aspecto como el espíritu del auténtico auto de carreras de Fórmula 1 McLaren para 2022.

A James Key (Executive Director, Technical en McLaren F1) le agradó la flexibilidad de los diseñadores de Technic™ tanto como colaborar con ellos: *"Empezamos a trabajar en la próxima generación del auto de carreras tan pronto como se dio a conocer el proyecto. A partir de ahí, el proceso fue casi continuo hasta el último momento. Nos encantó mantener esa relación de trabajo tan ágil con el equipo de Technic™. El resultado final se ve fantástico".*

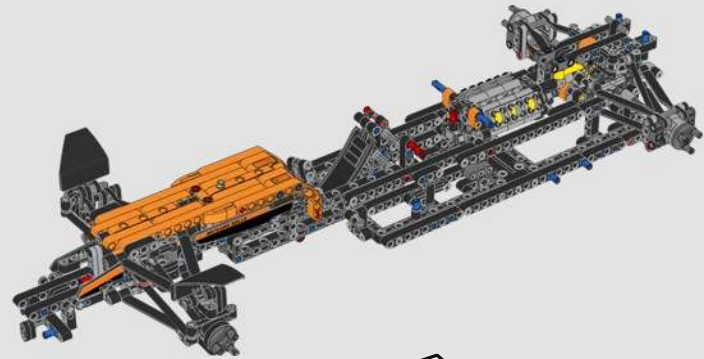
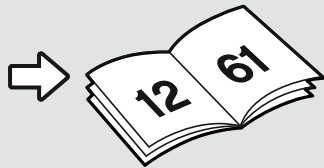
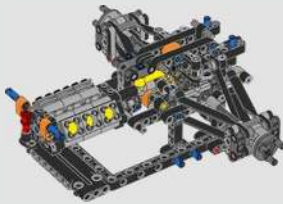
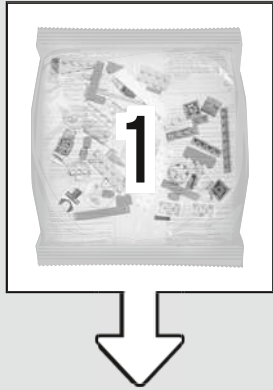

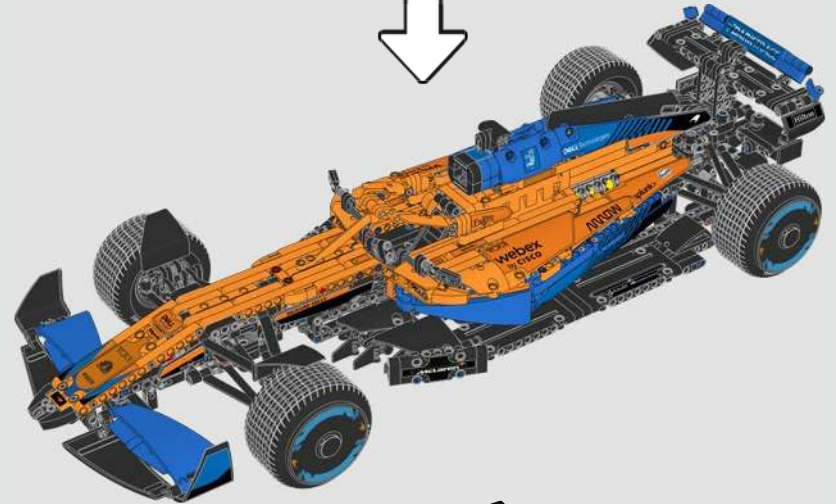
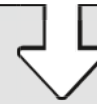
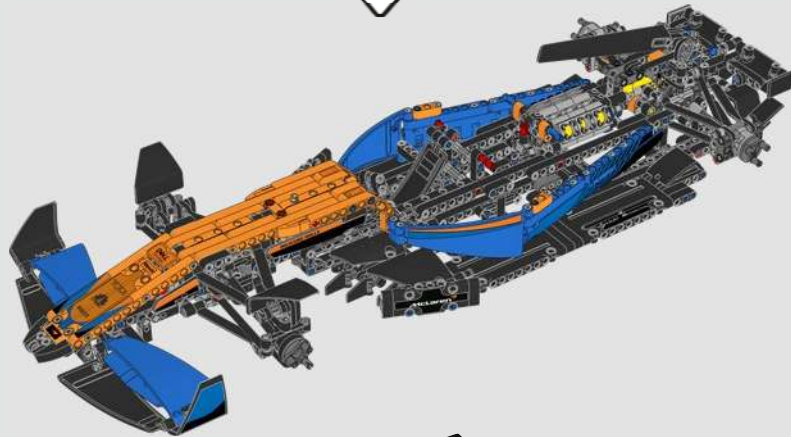
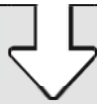

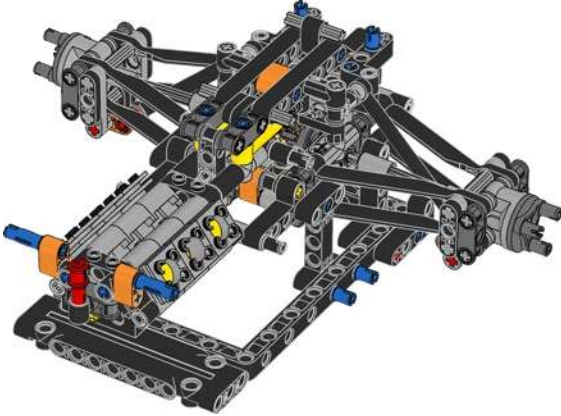
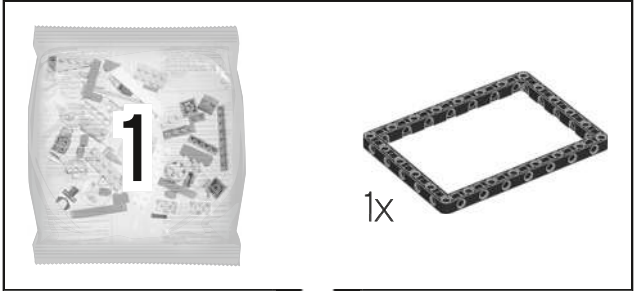

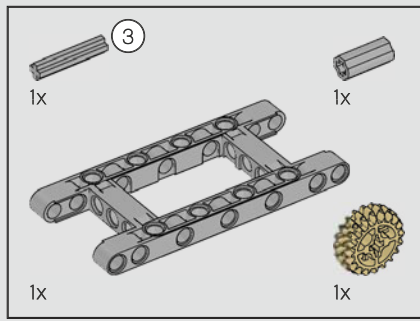

1

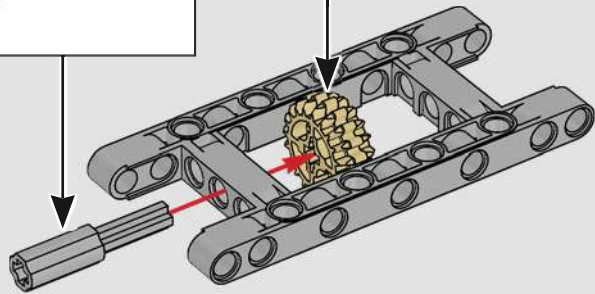
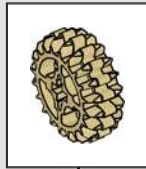
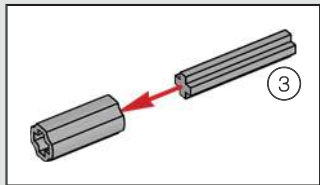

2

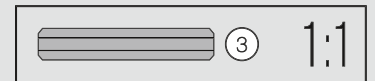
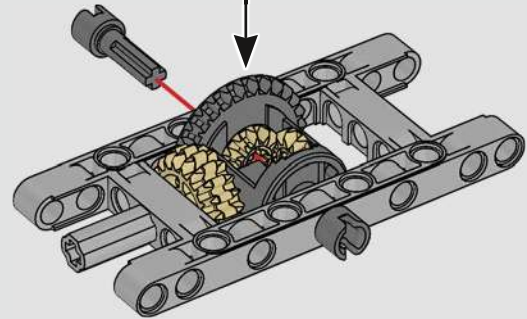
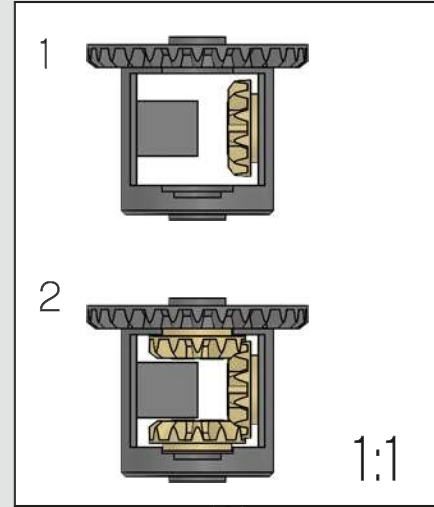

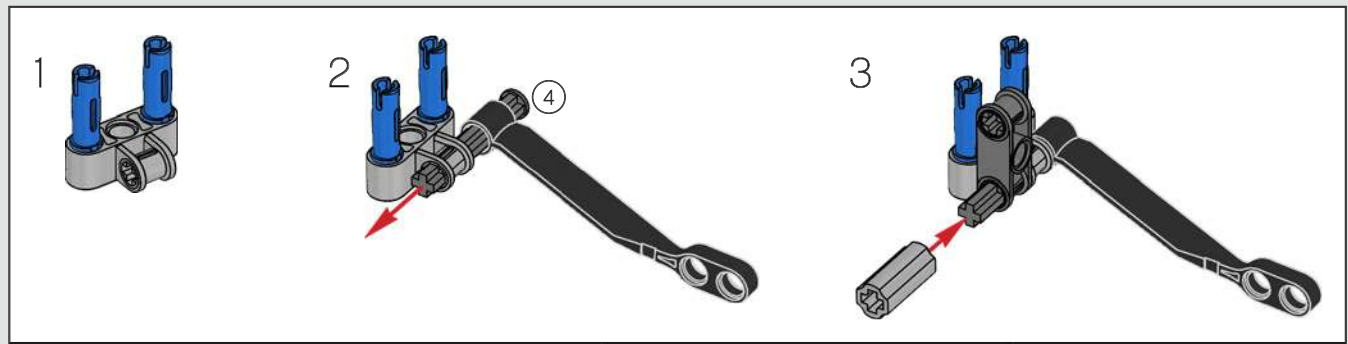
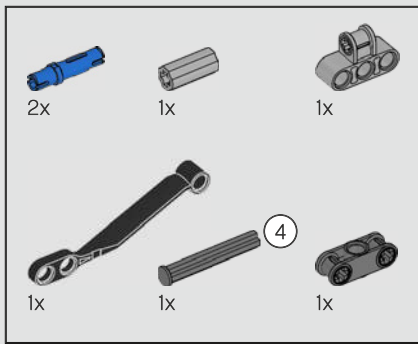

3

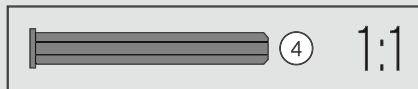
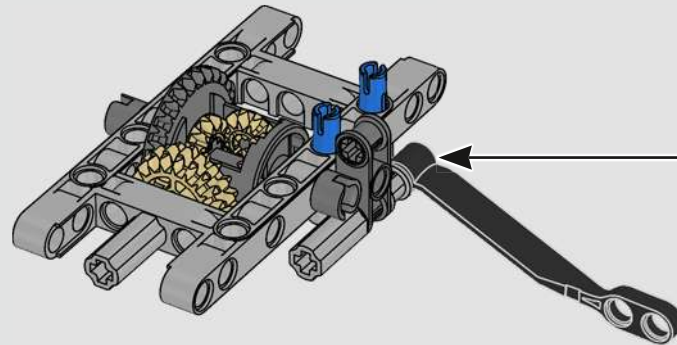

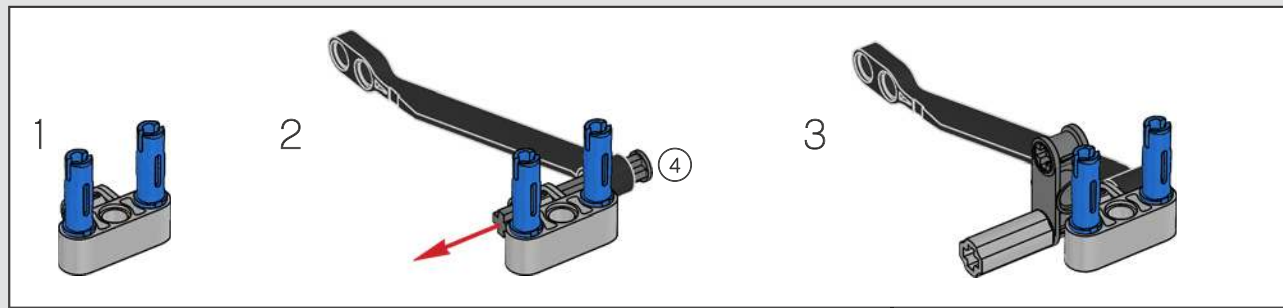
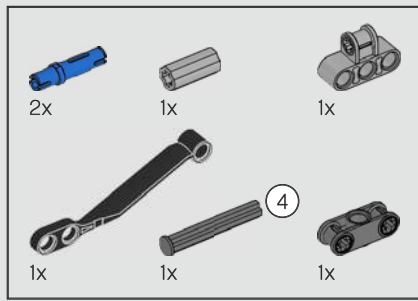

4

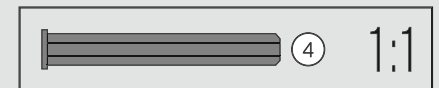
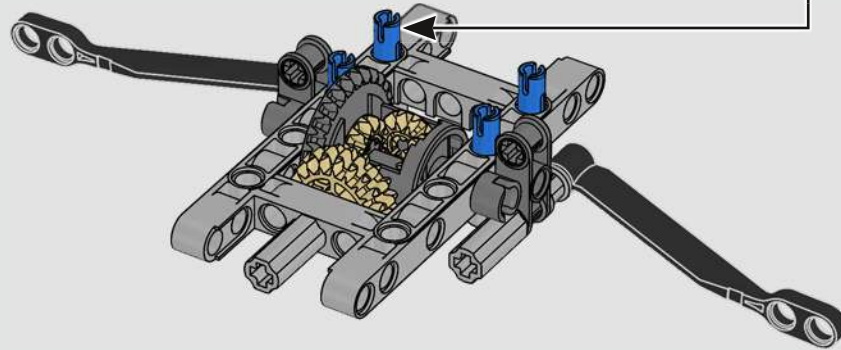

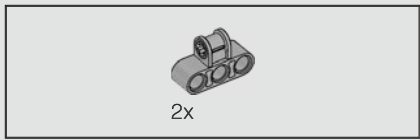

5

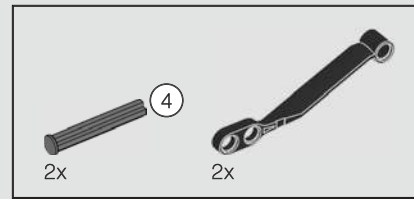
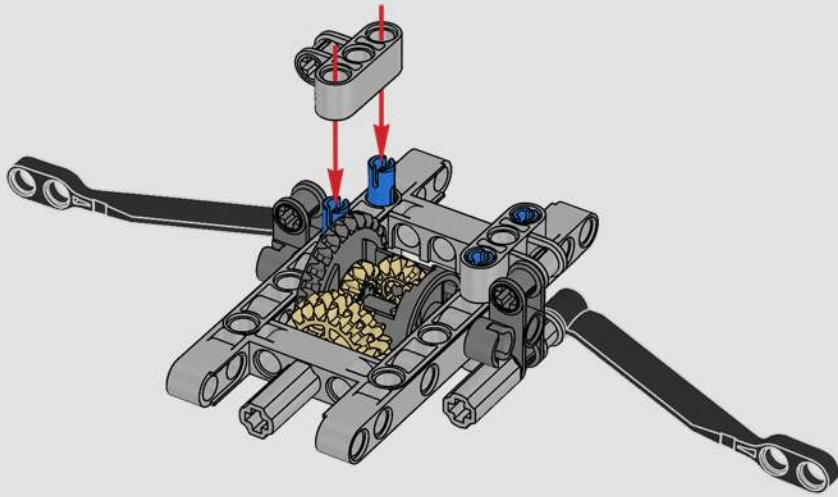

6

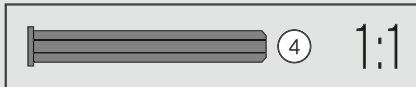
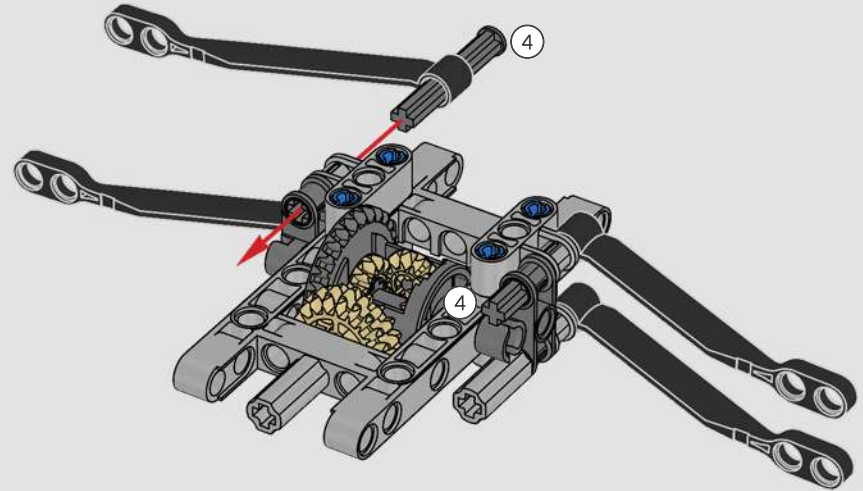

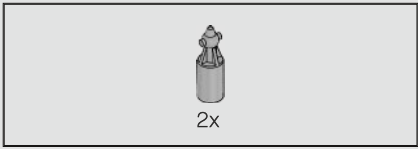

7

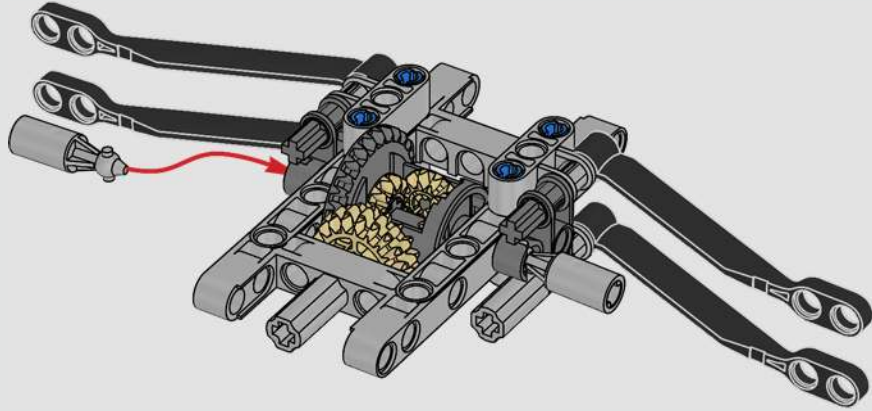

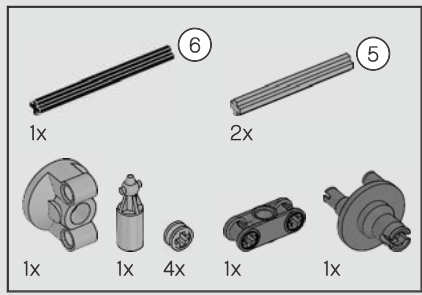

8

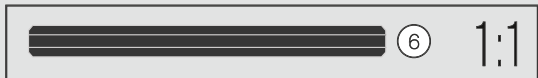
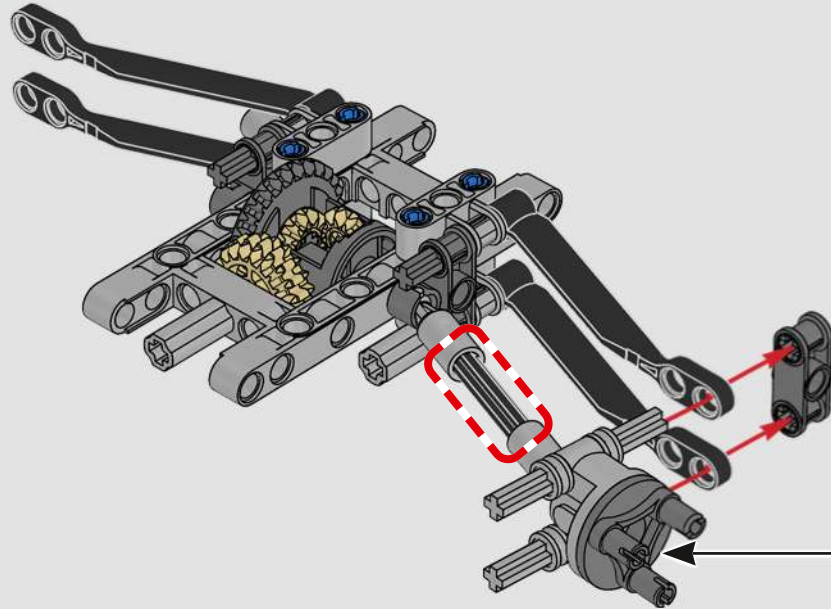
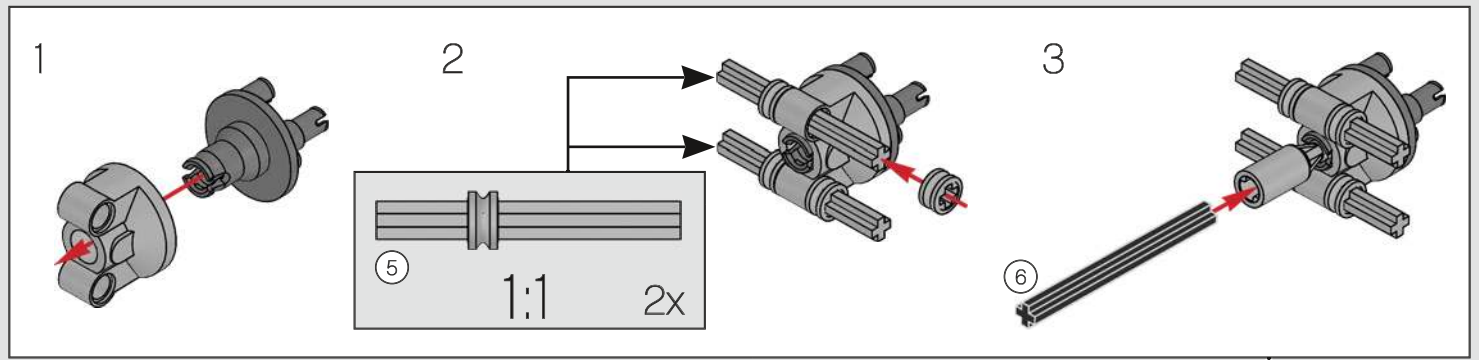

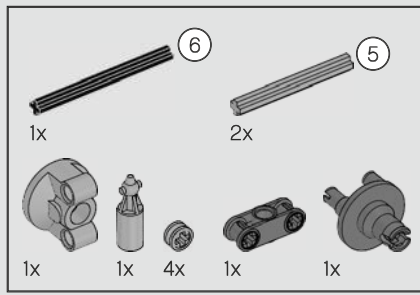

9

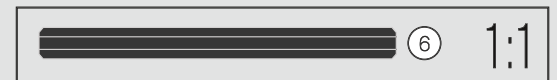
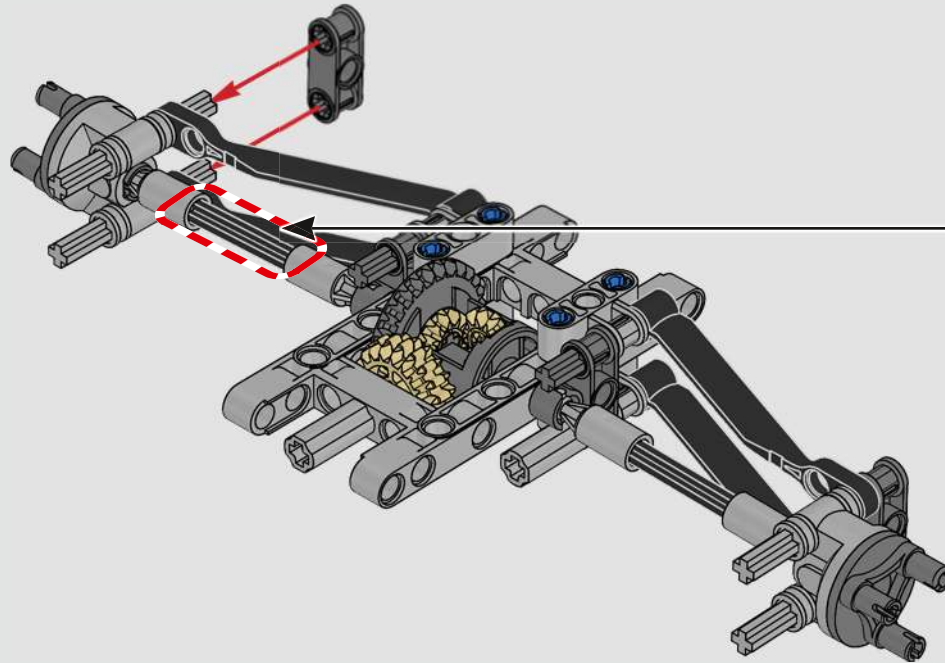
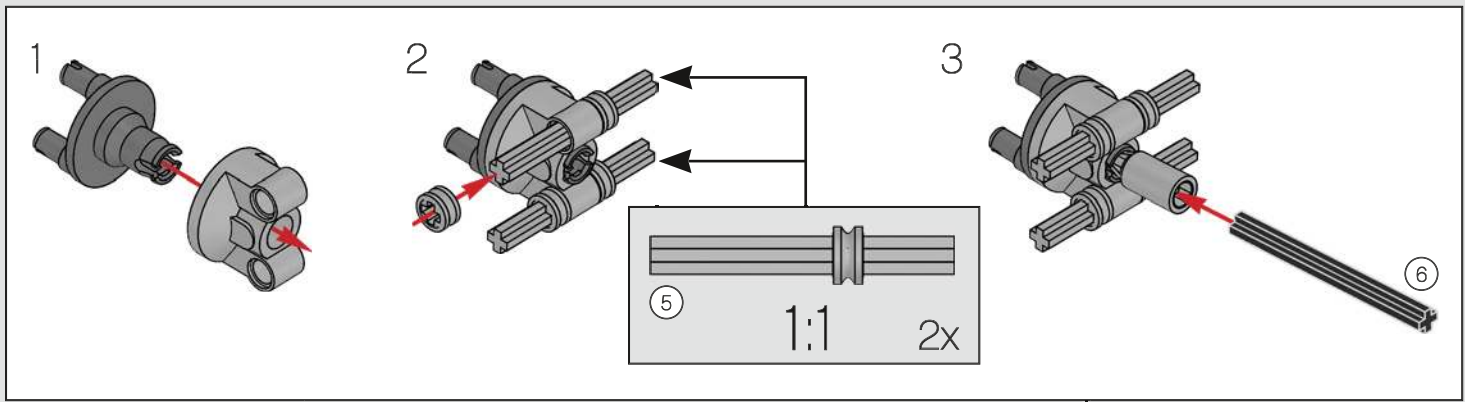

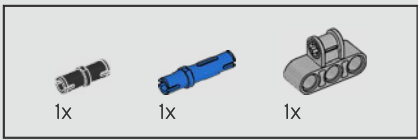

10

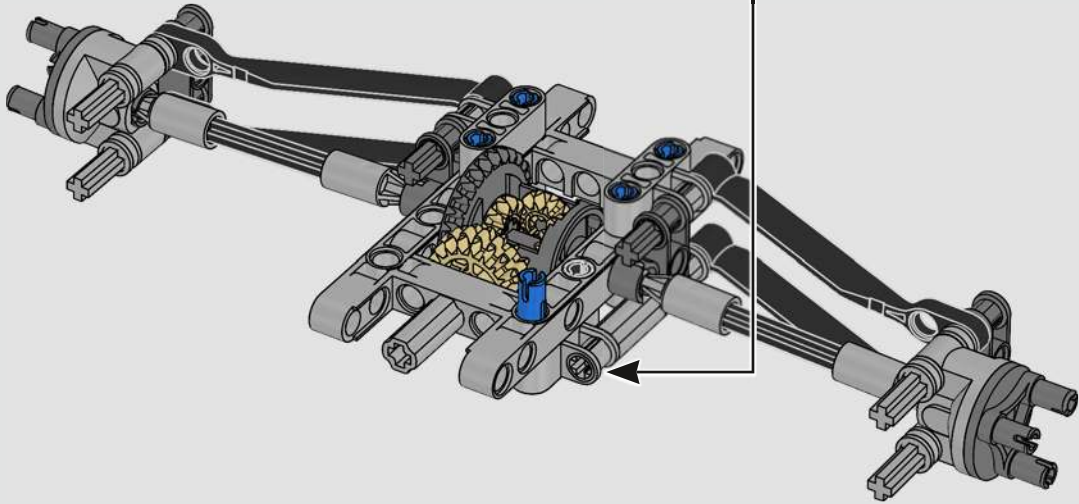
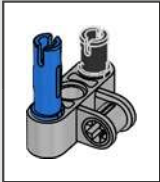

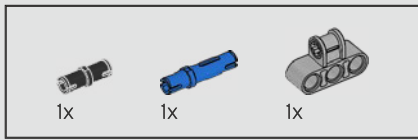

11

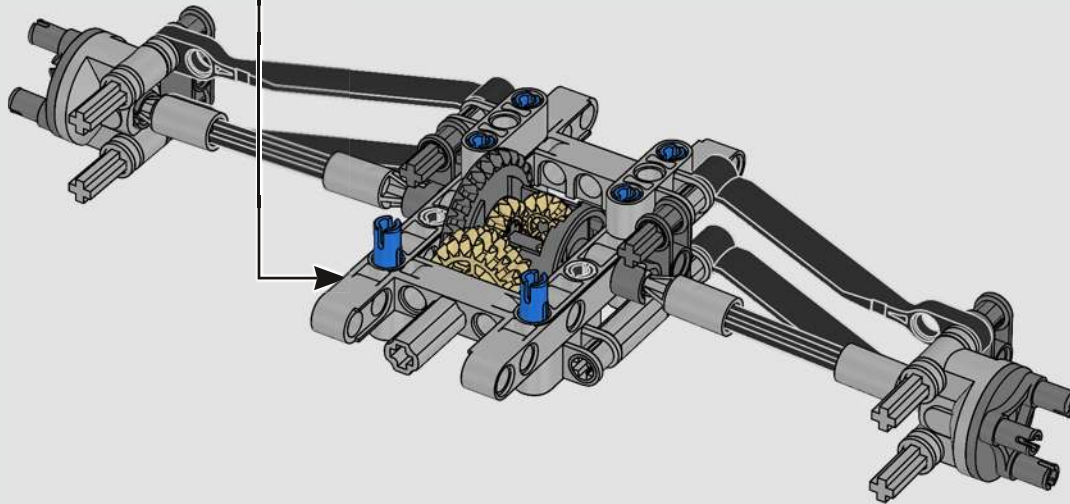
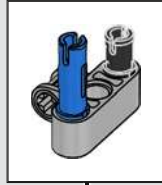

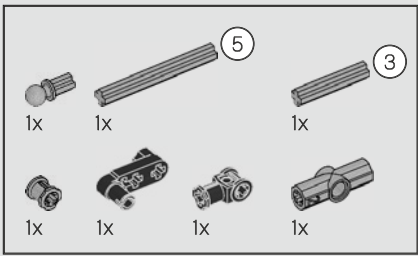

12

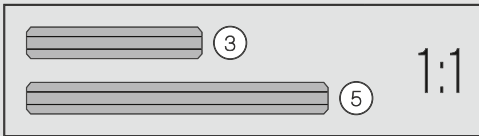
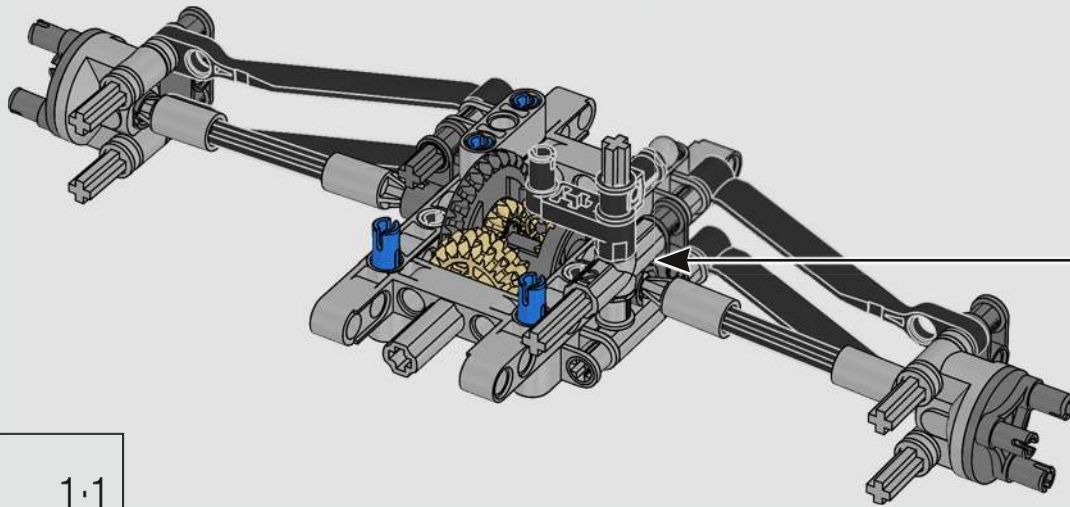
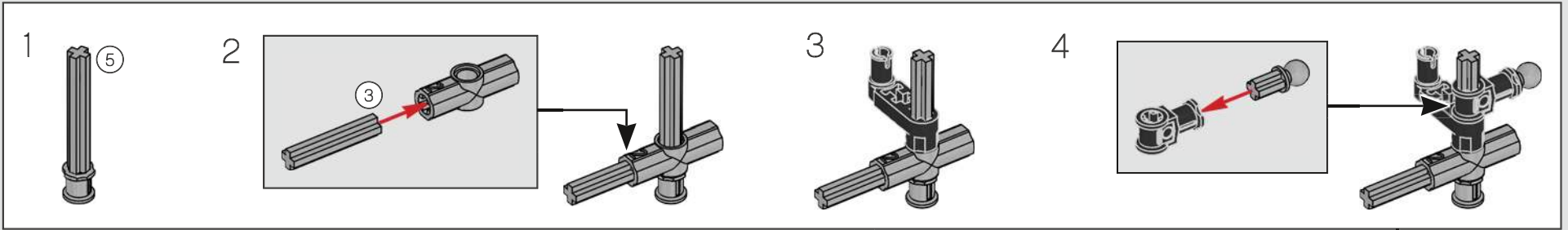

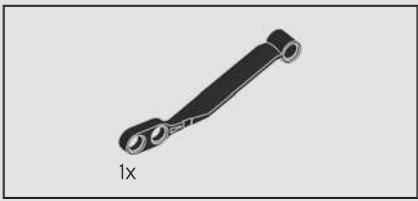

13

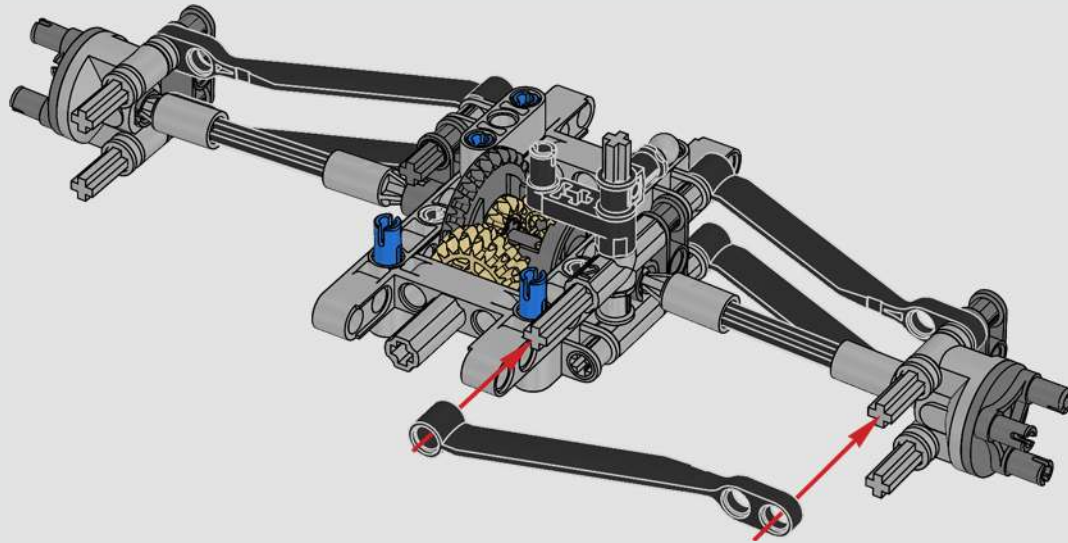

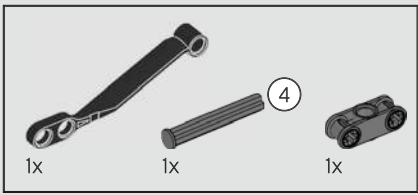

14

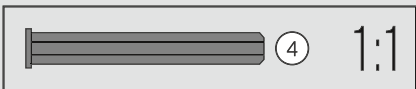
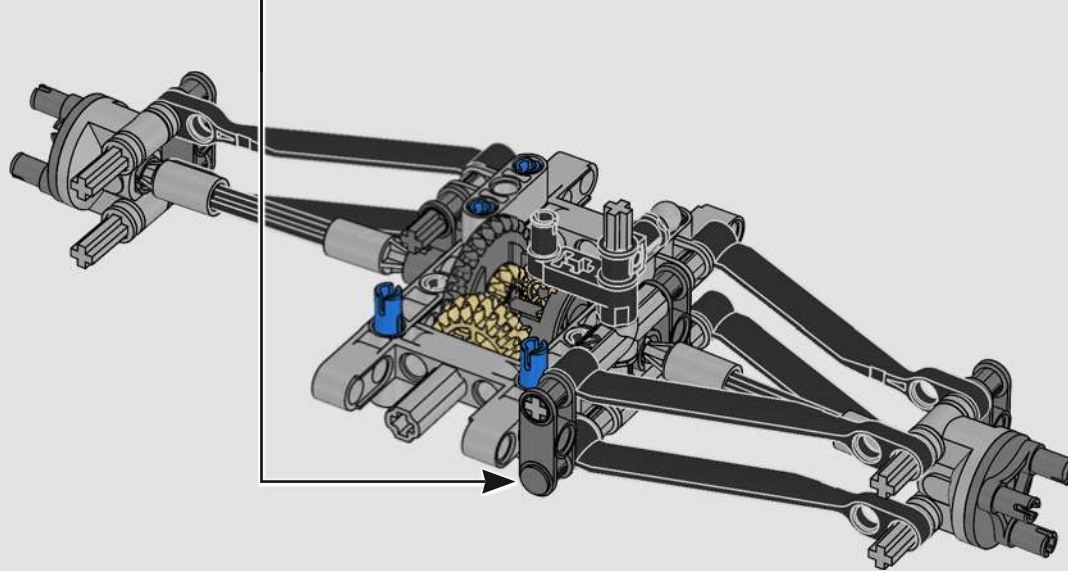
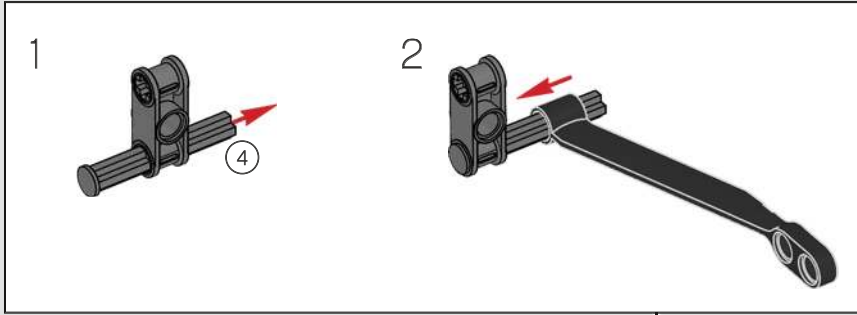

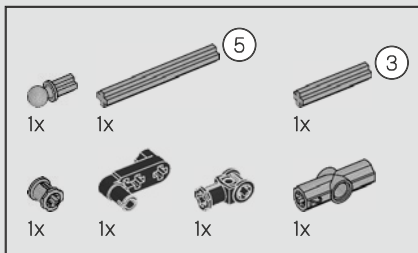

15

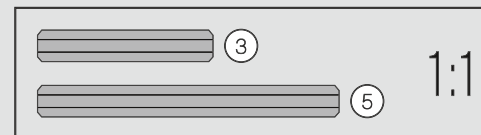
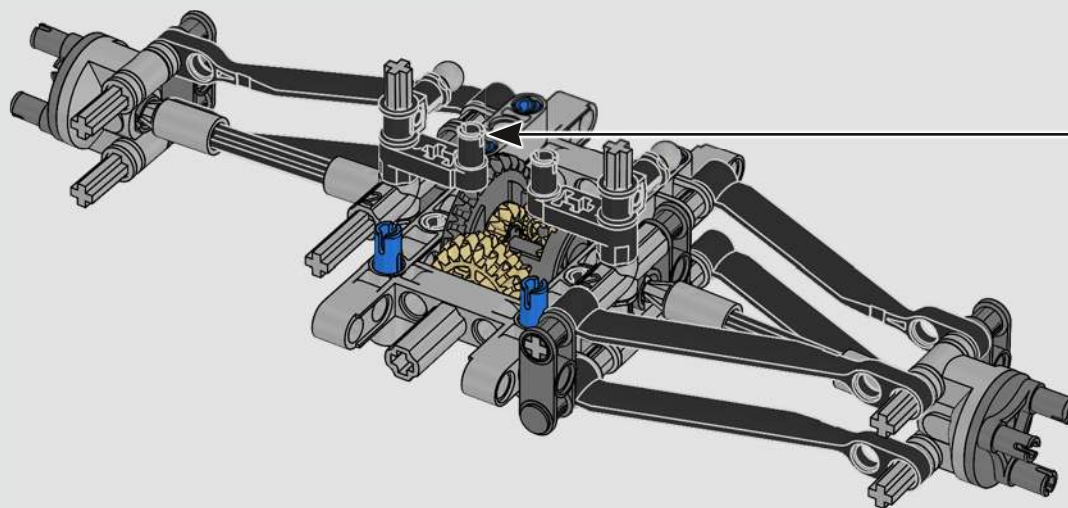
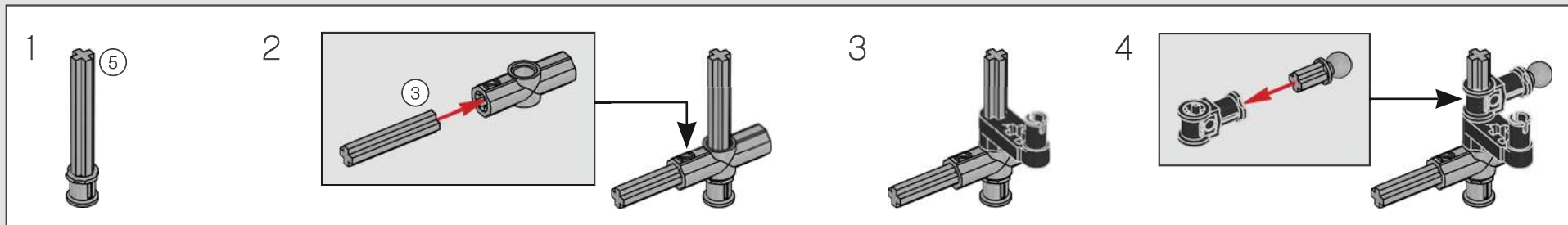

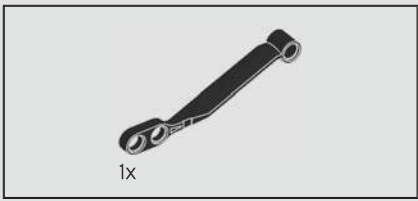

16

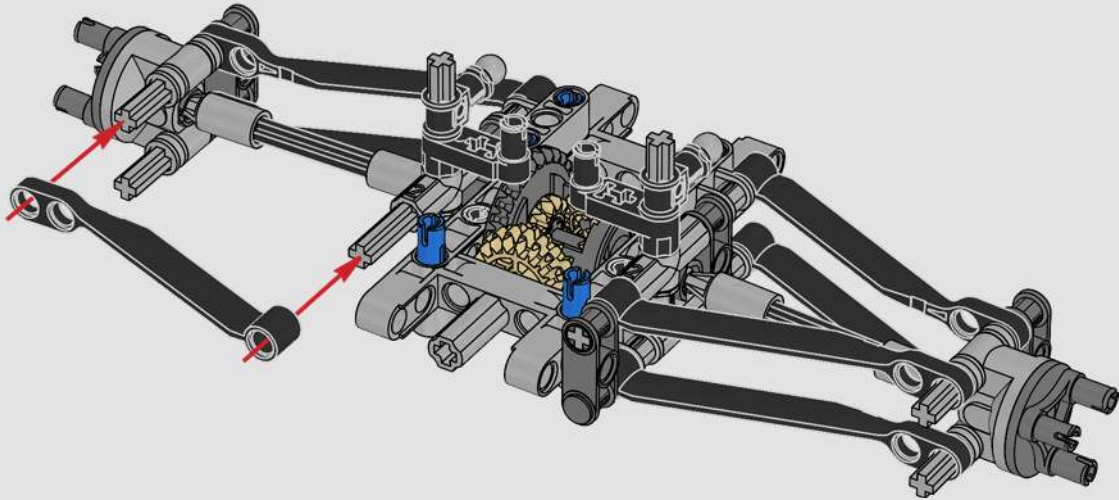

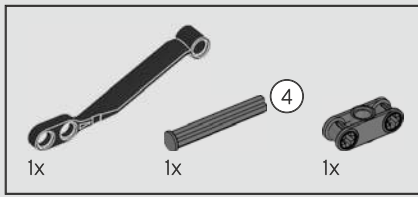

17

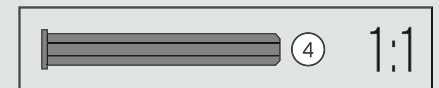
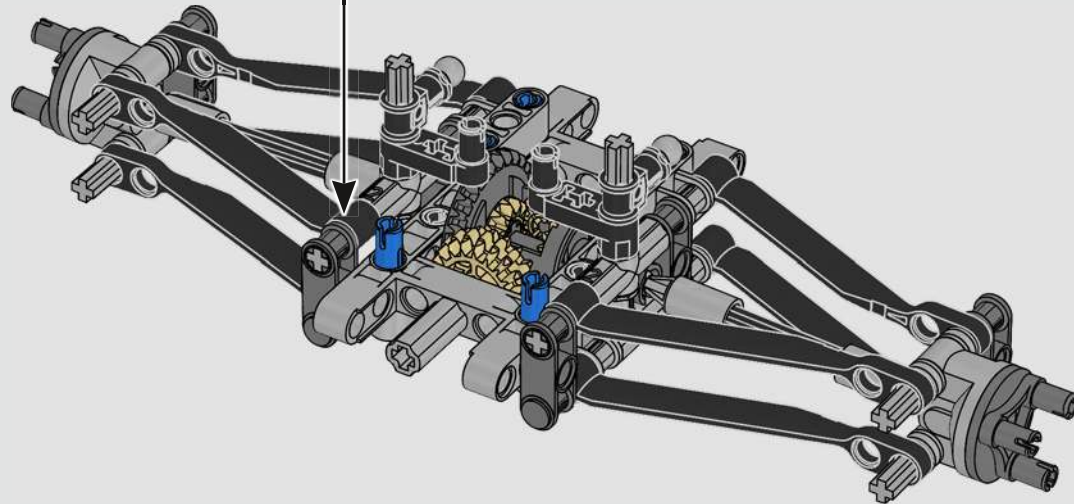
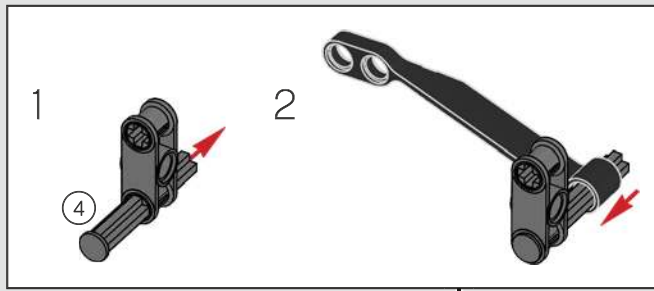



18

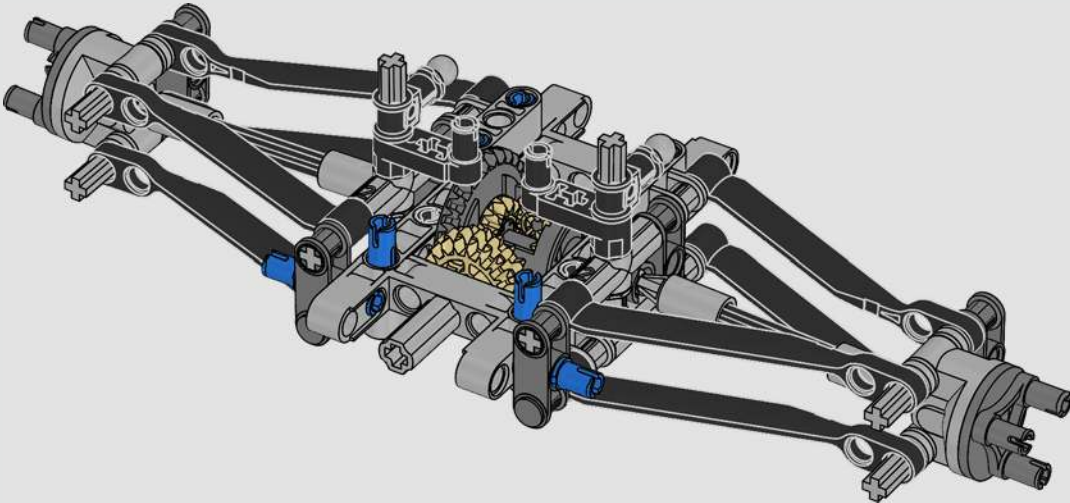

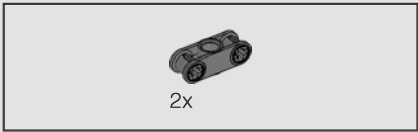

19

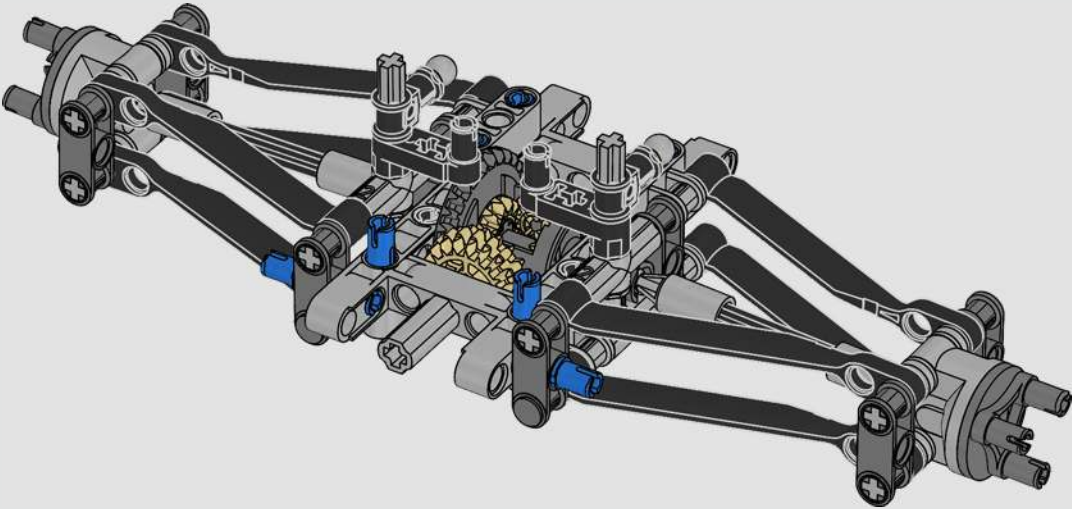

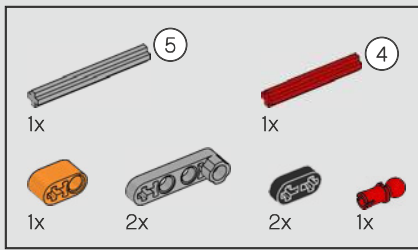

20

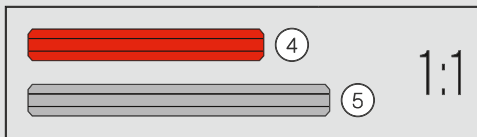
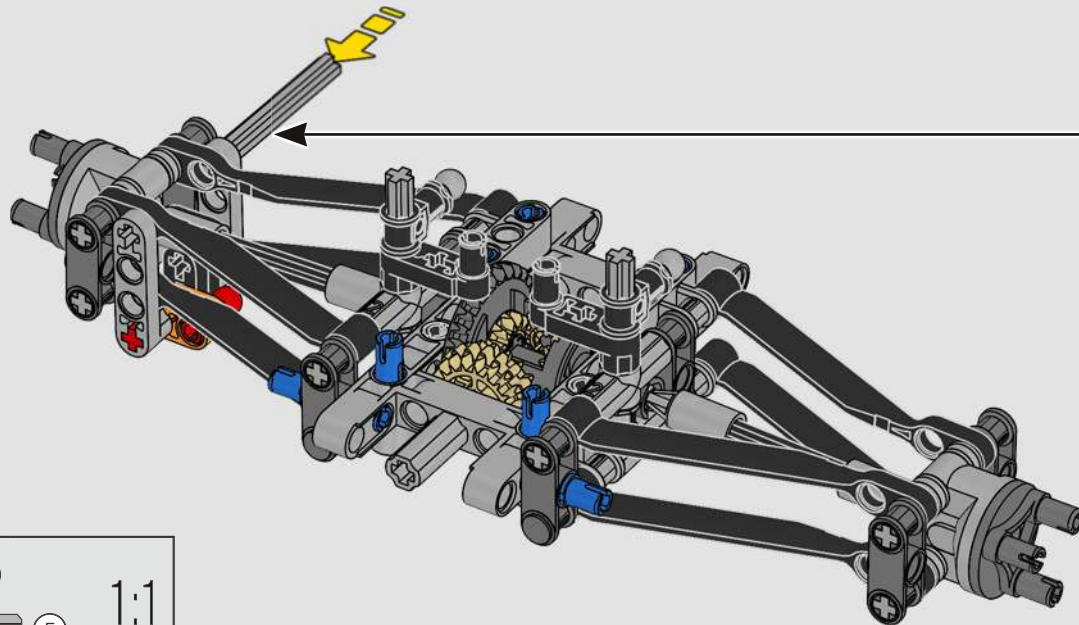
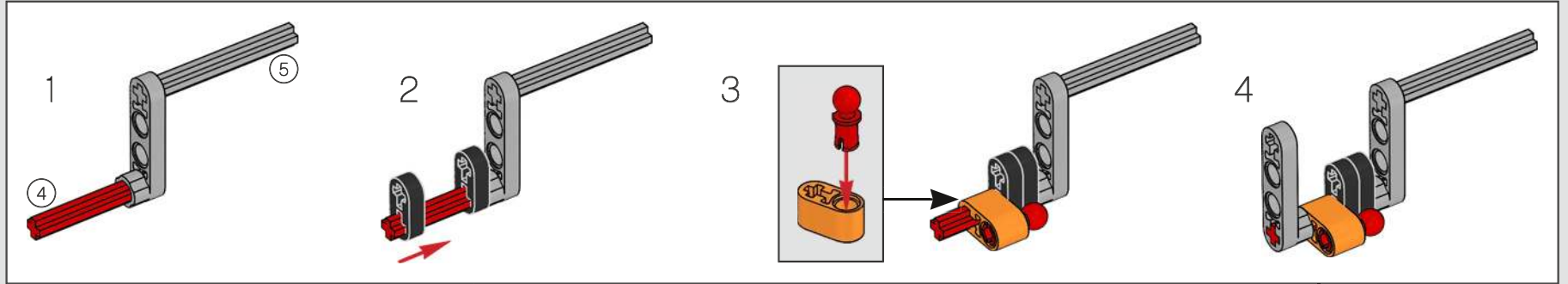

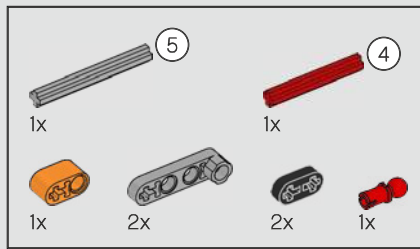

21

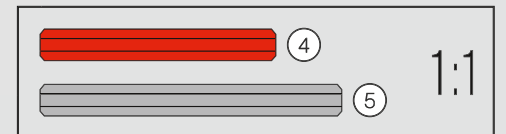
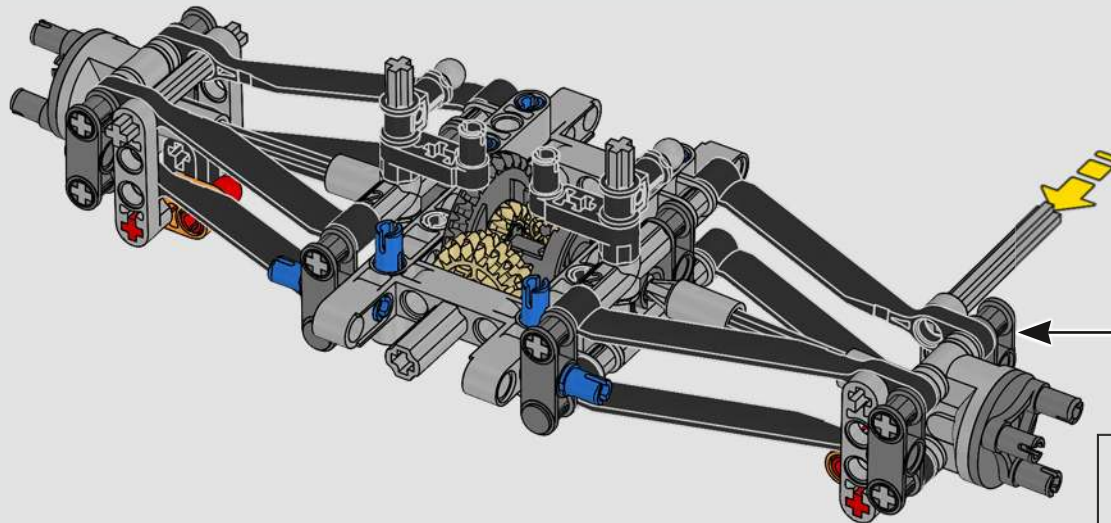
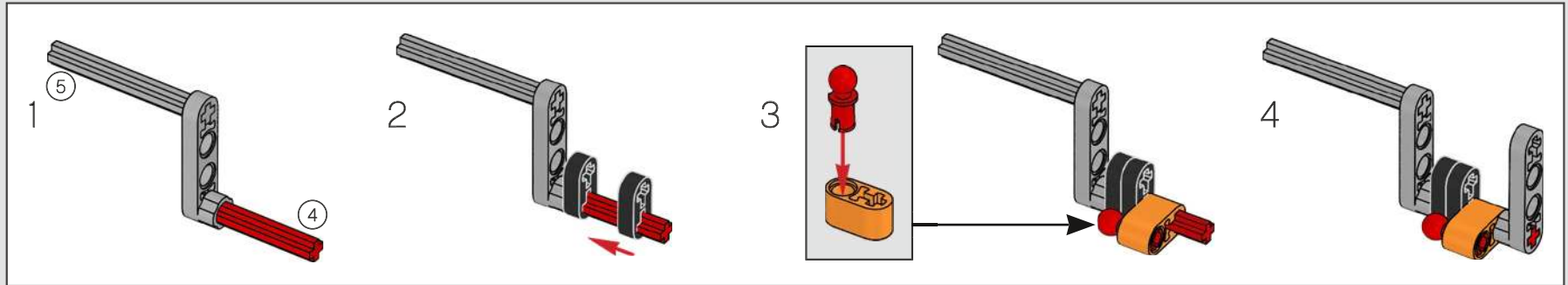

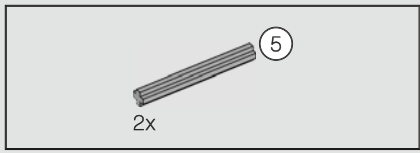

22

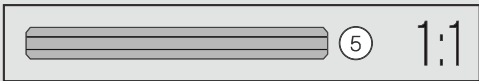
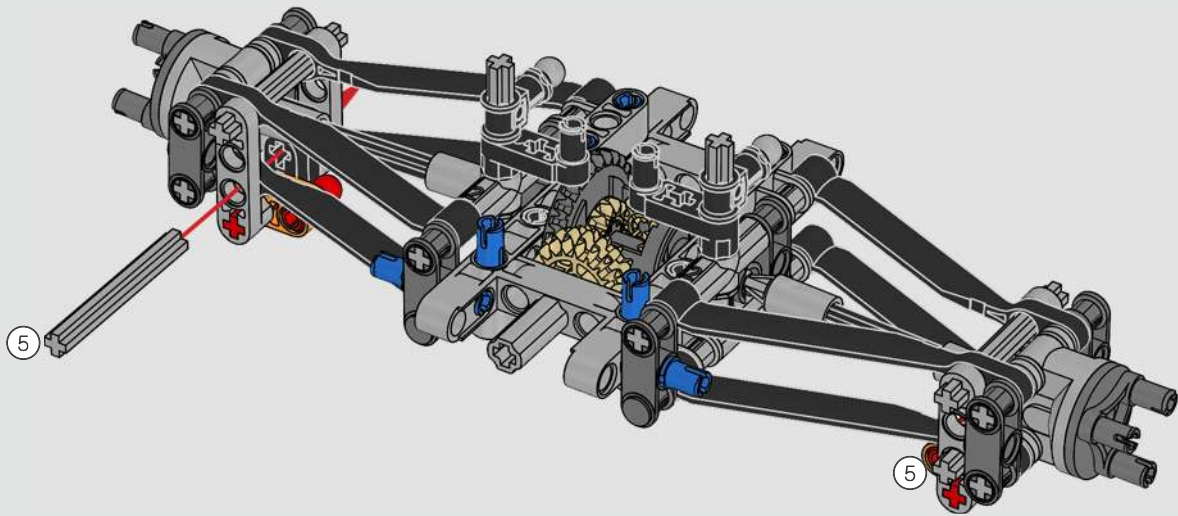



23

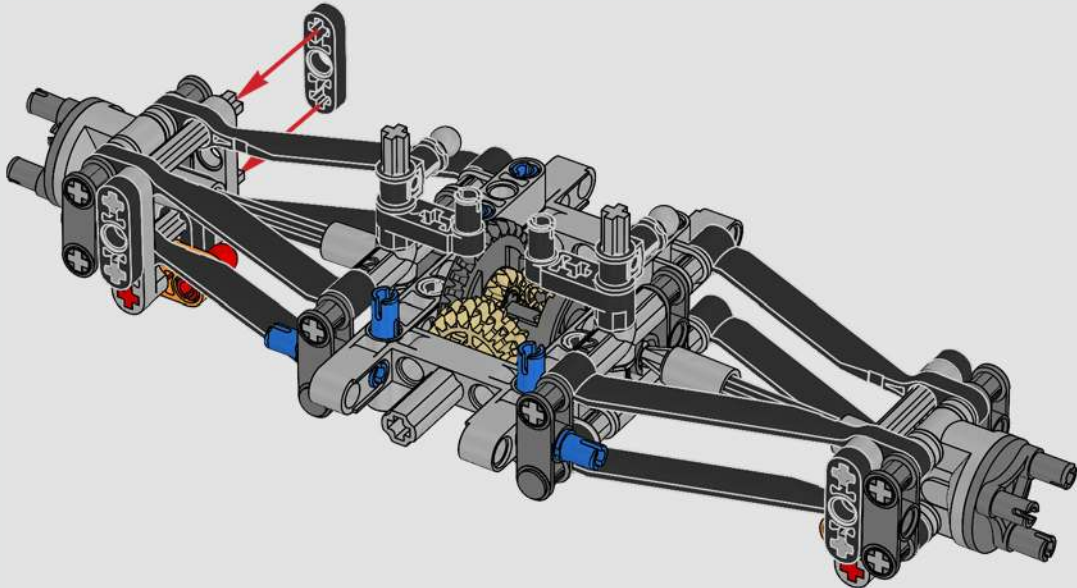

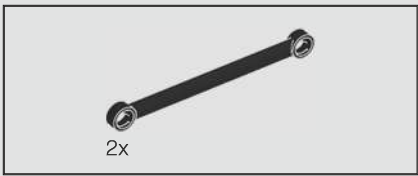

24

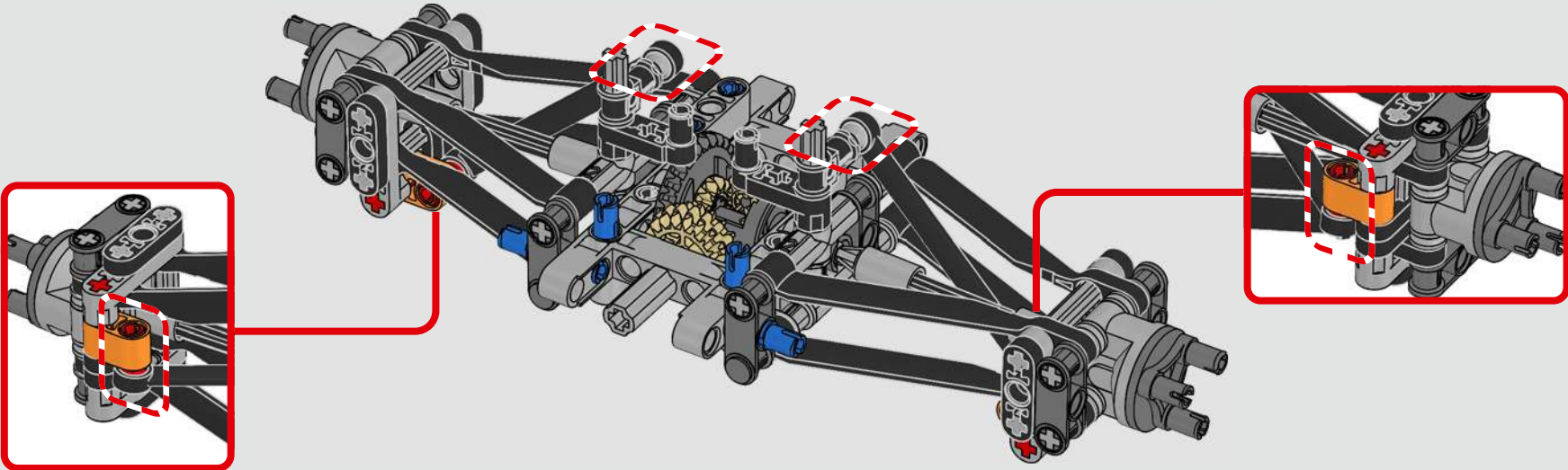

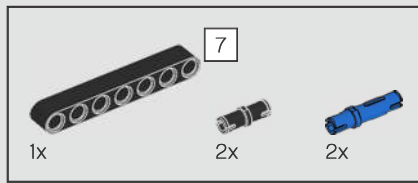

25

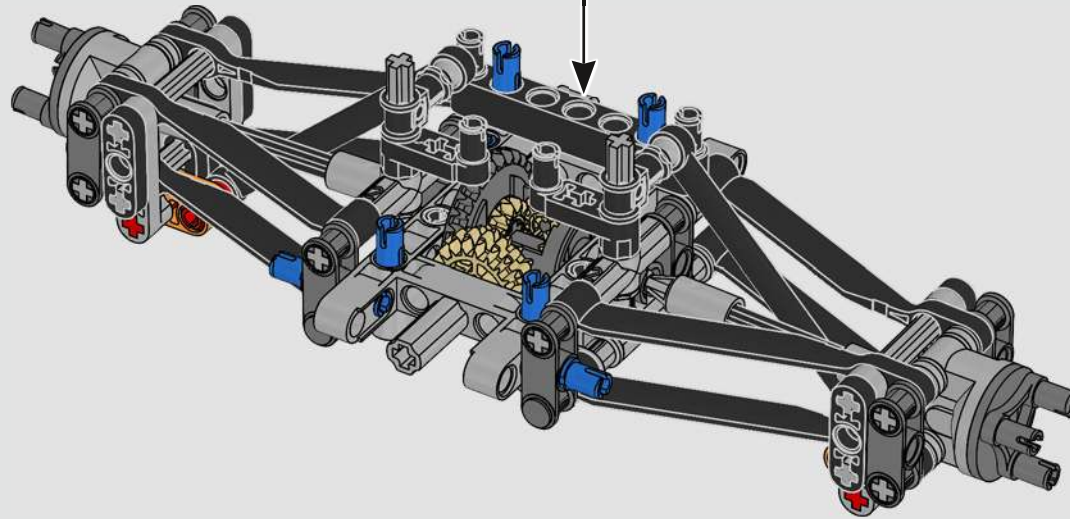
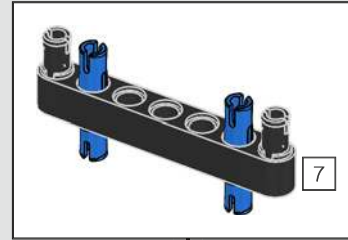

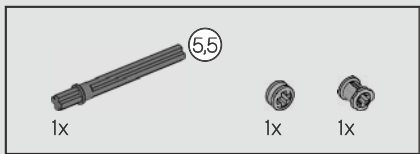

26

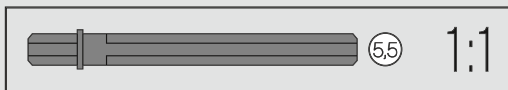
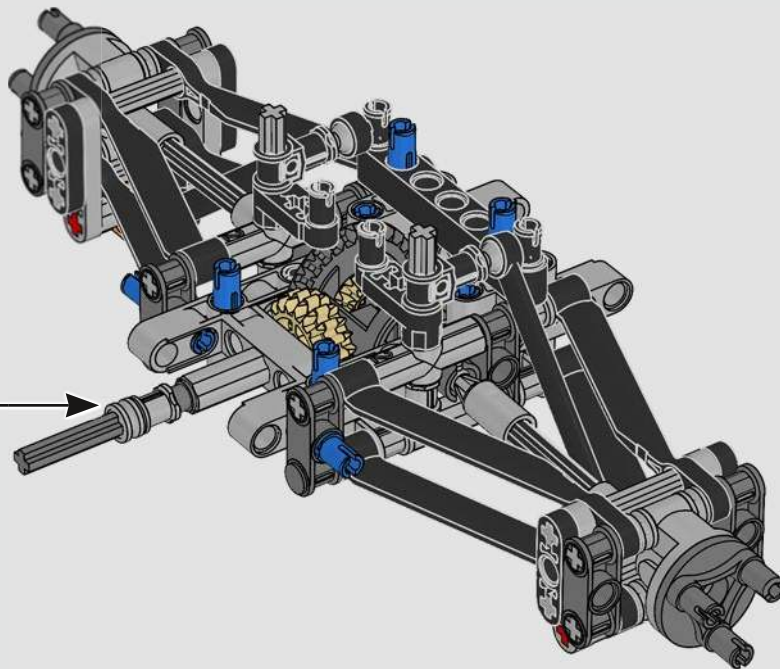
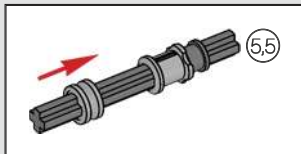

36

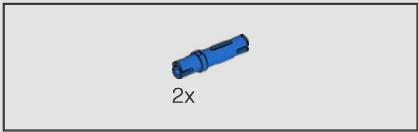

27

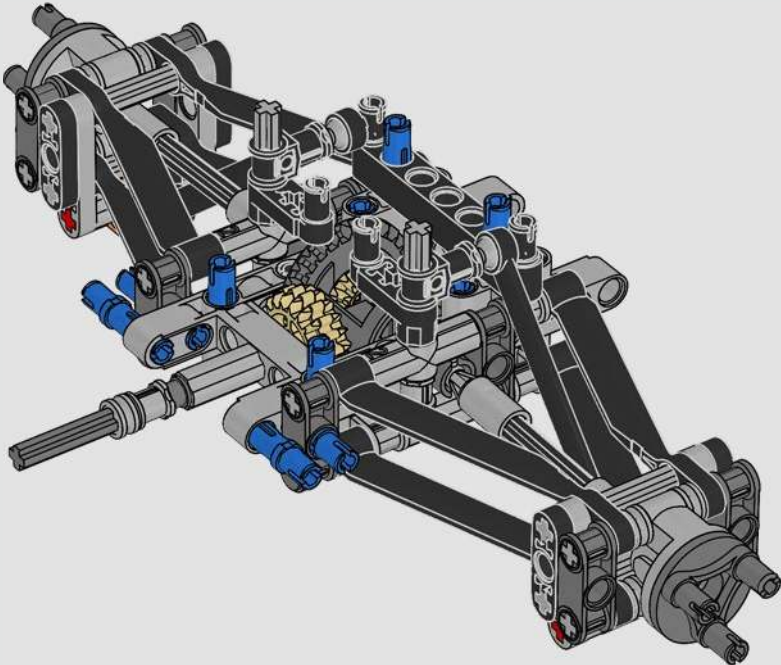

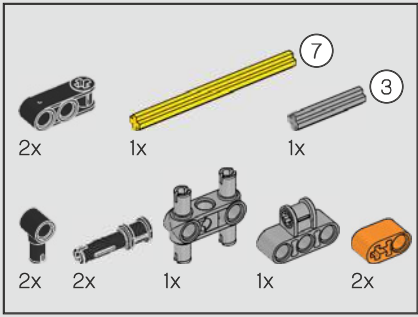

28

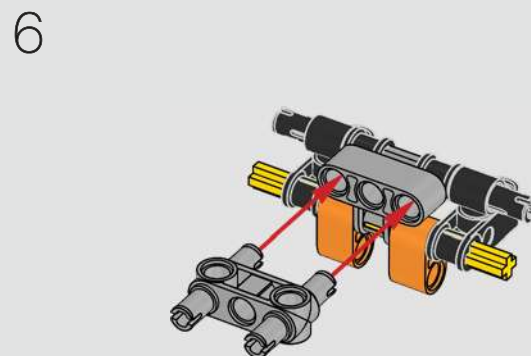
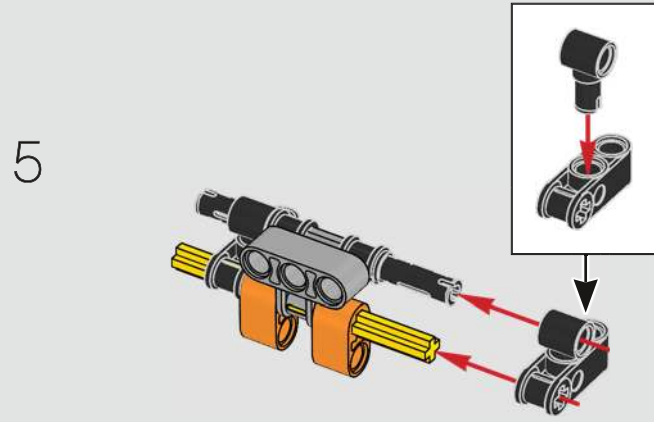
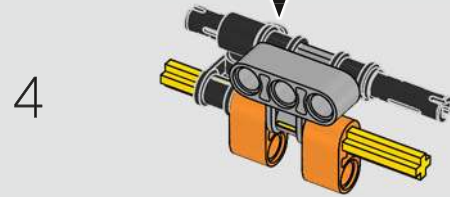
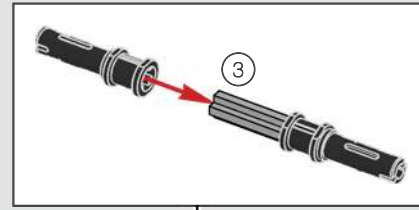
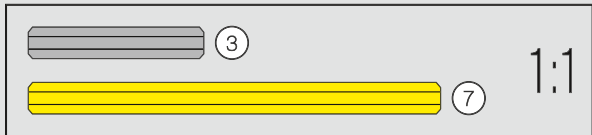
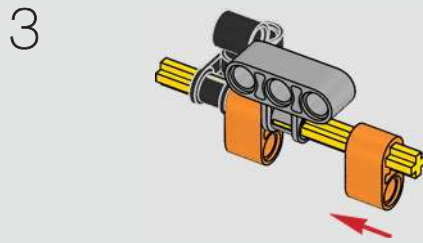
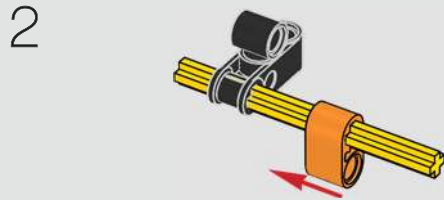
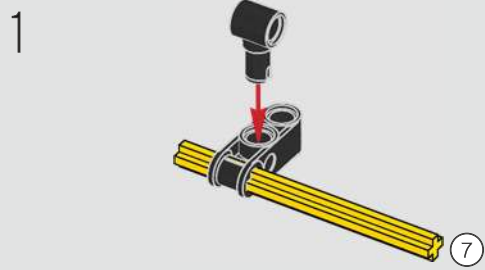

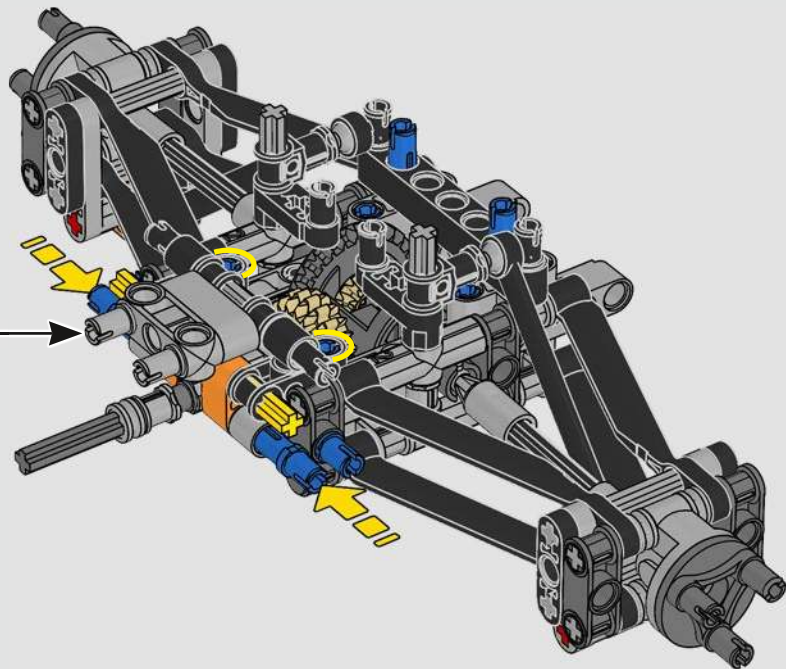

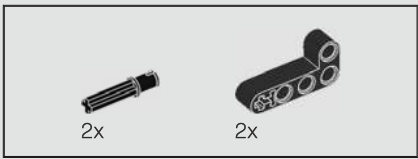

29

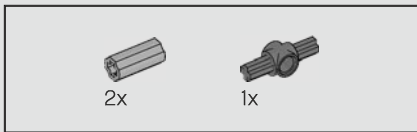
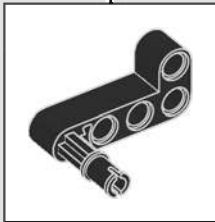
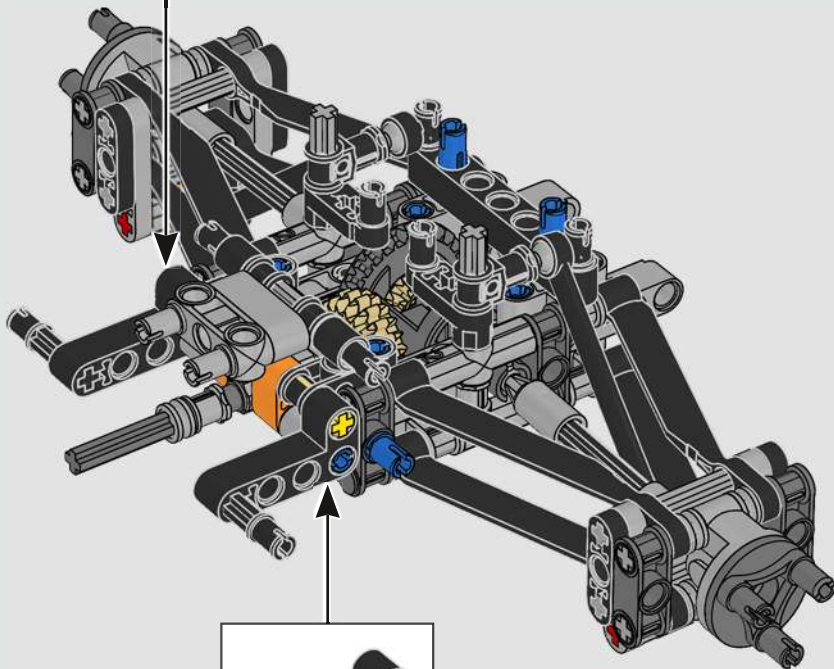

30

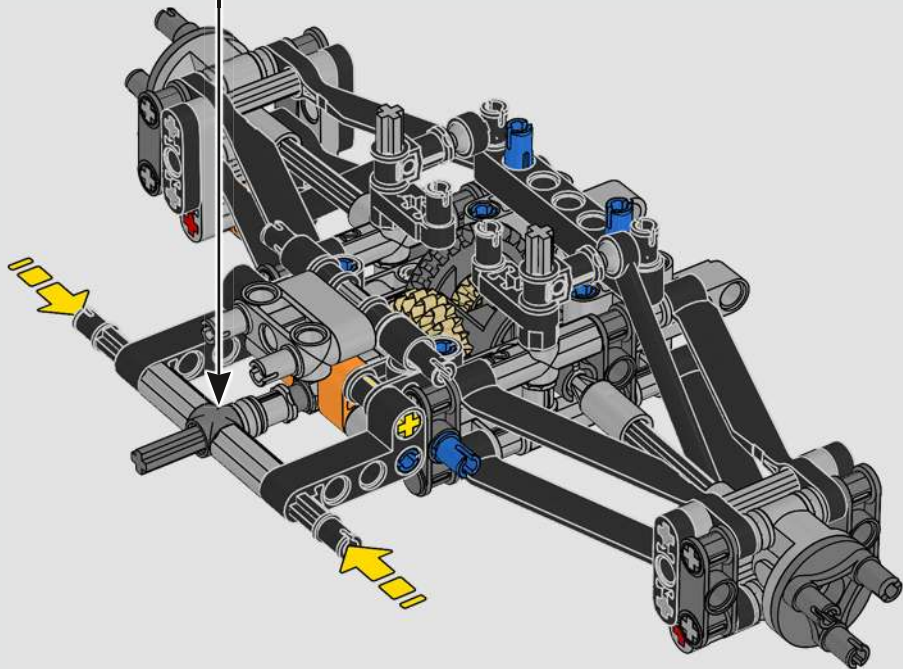
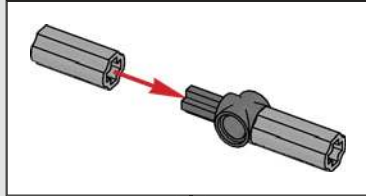



31

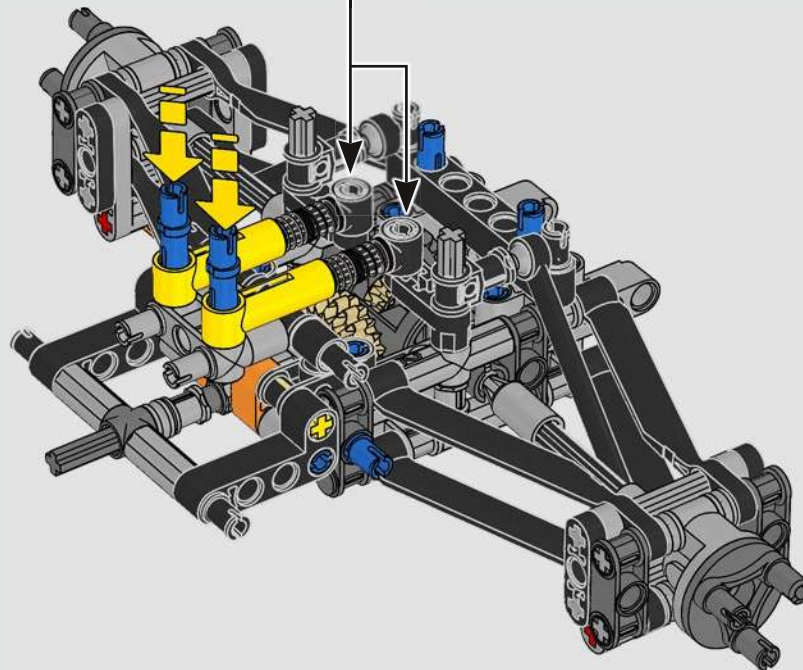
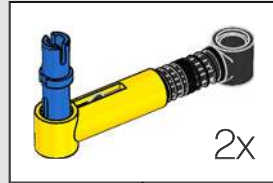

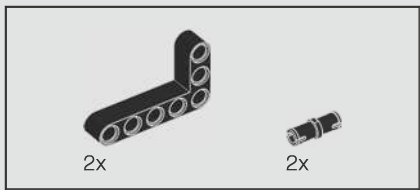

32

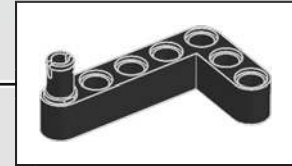
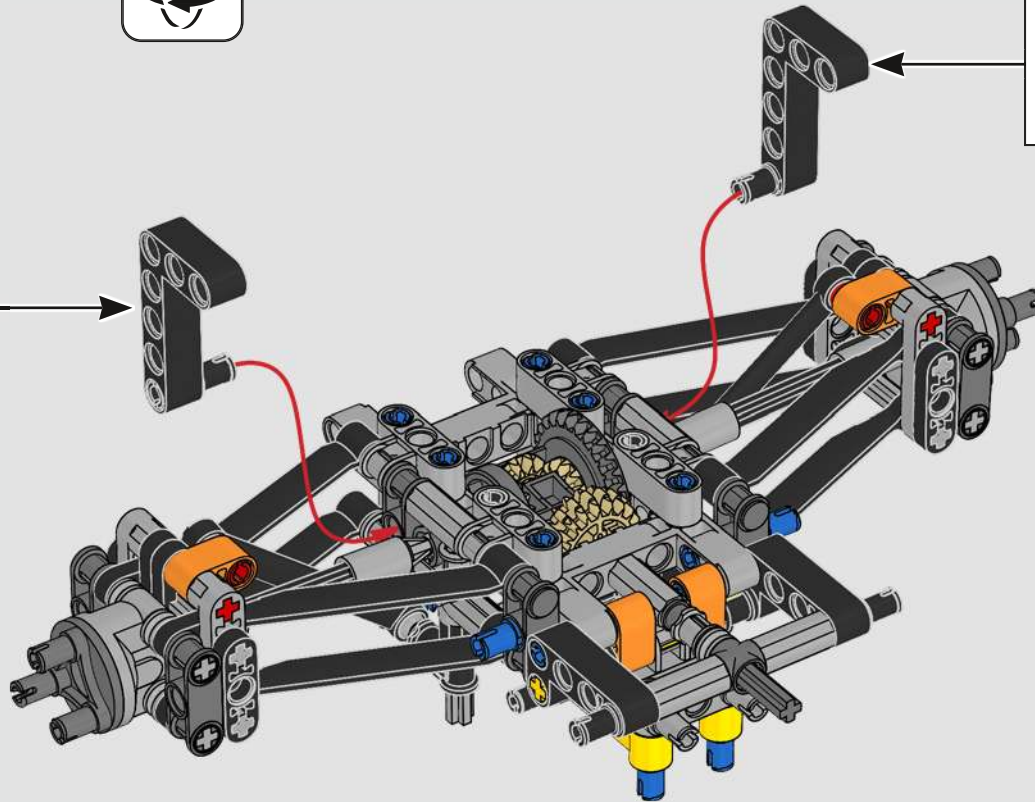
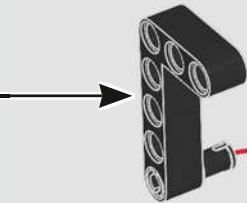

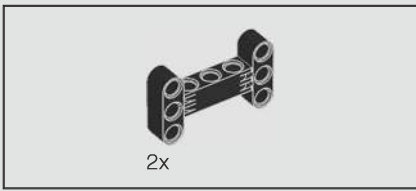

33

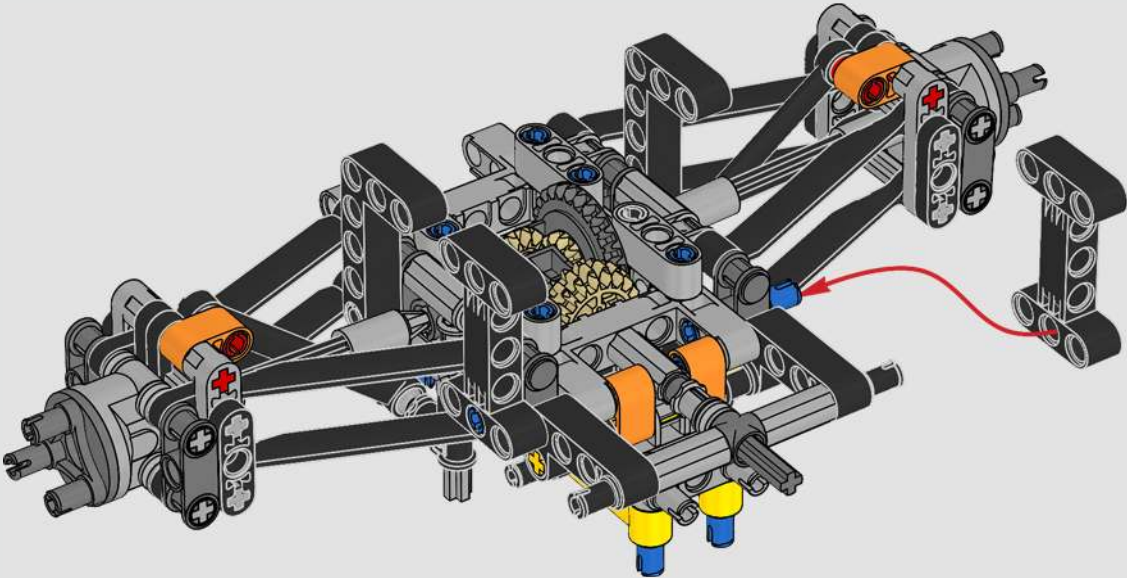

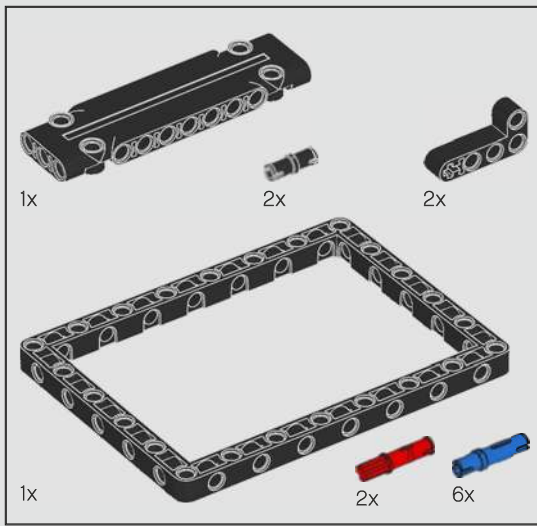

34

1

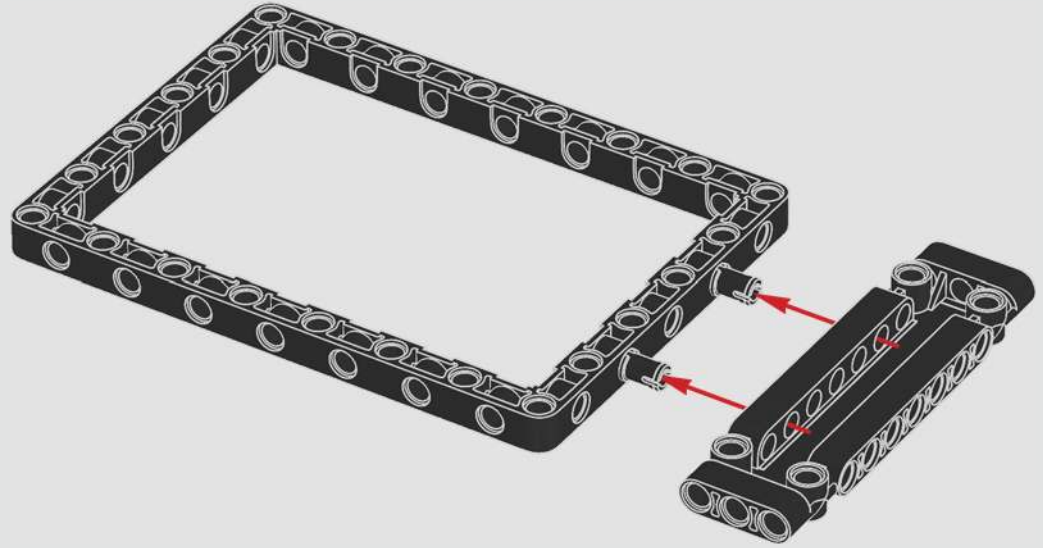

2

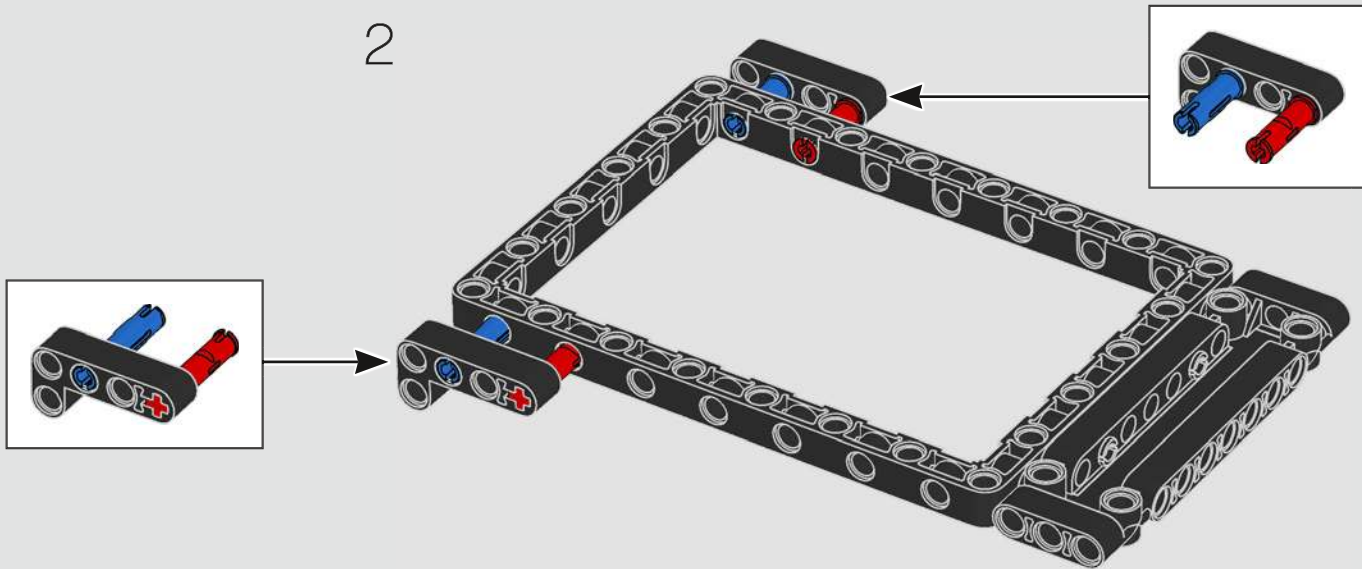

3

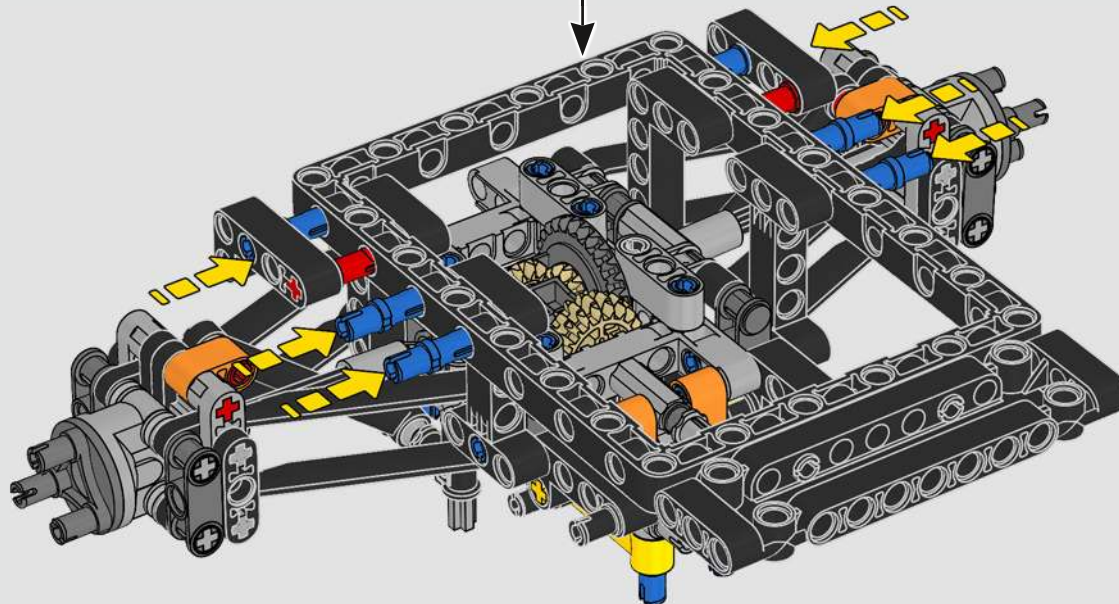
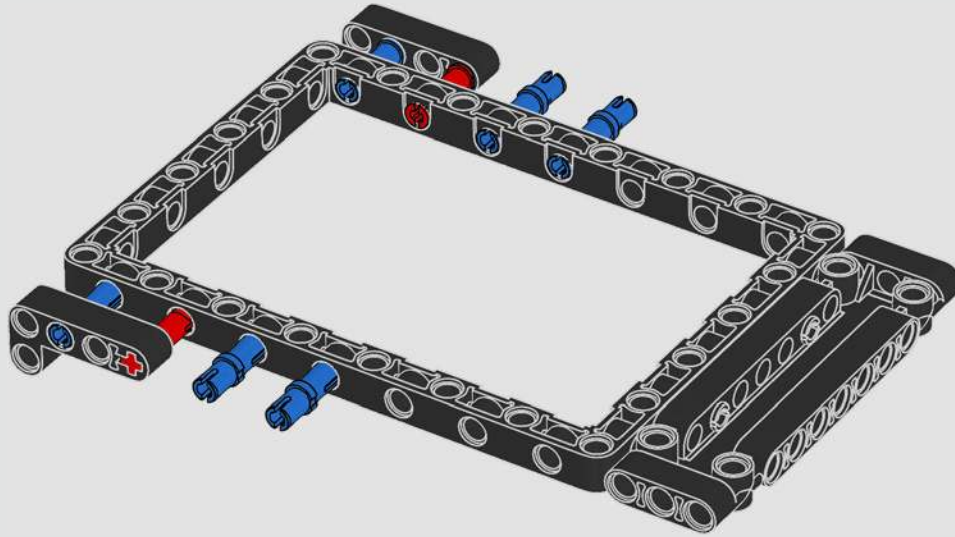

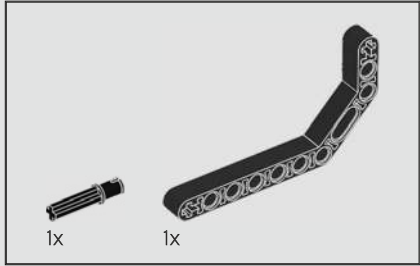

35

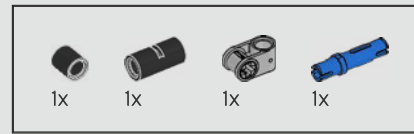
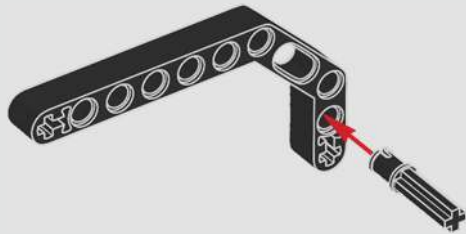

36

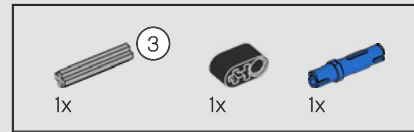
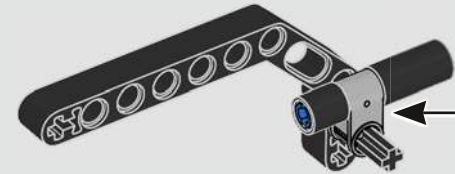
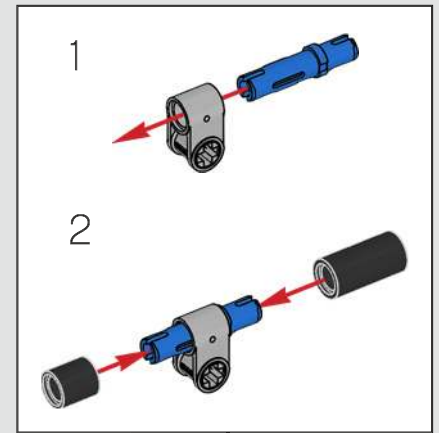

37

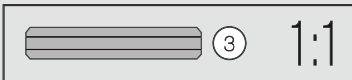
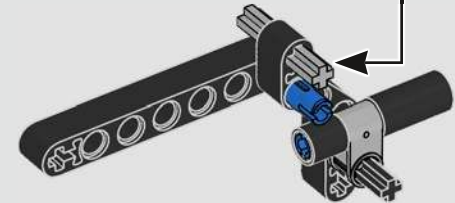
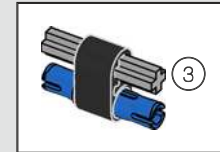

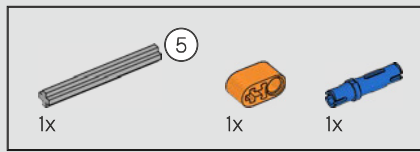

38

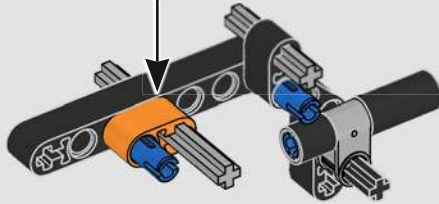
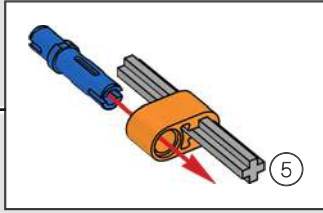

40

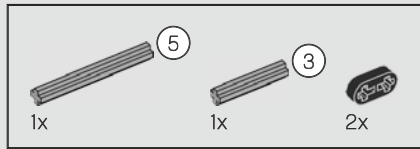
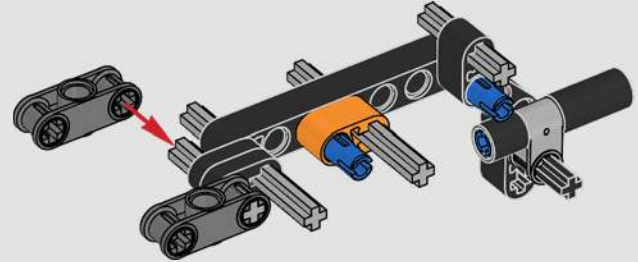

39

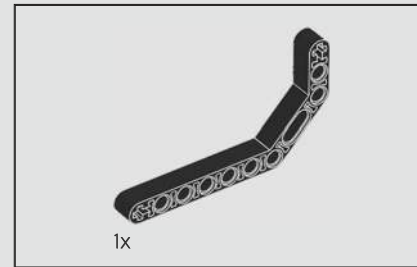
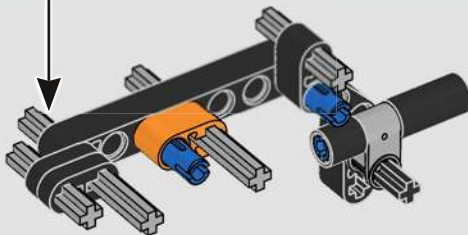
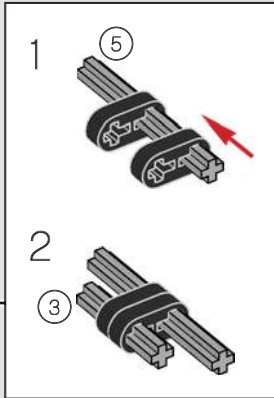

41

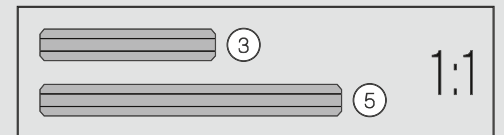
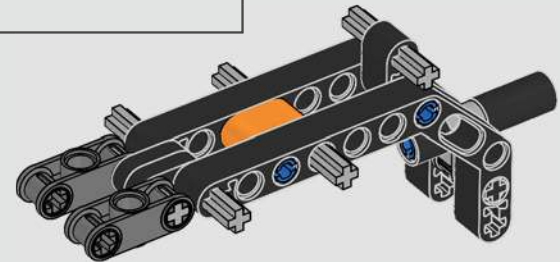

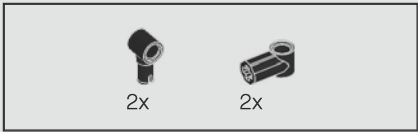

42

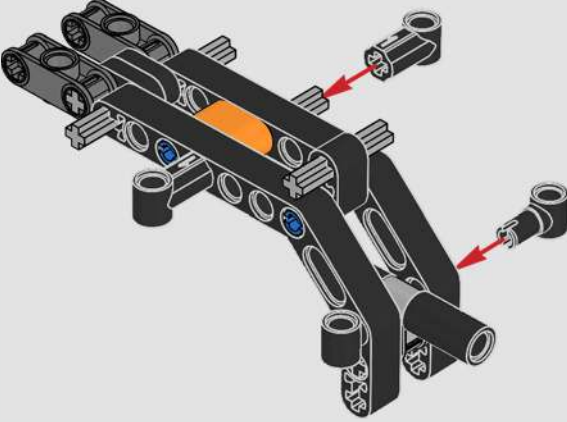

43

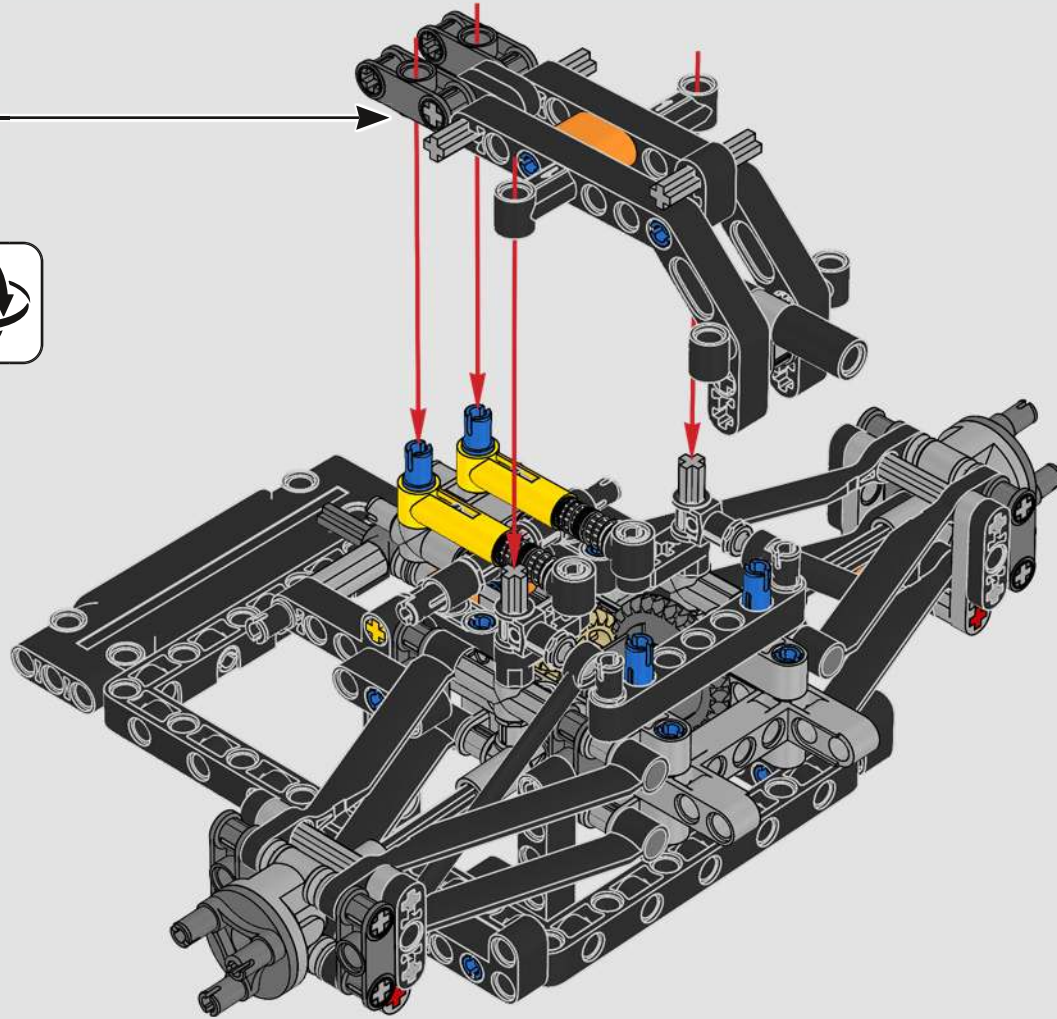

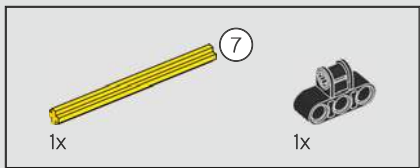

44

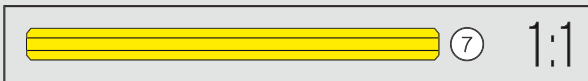
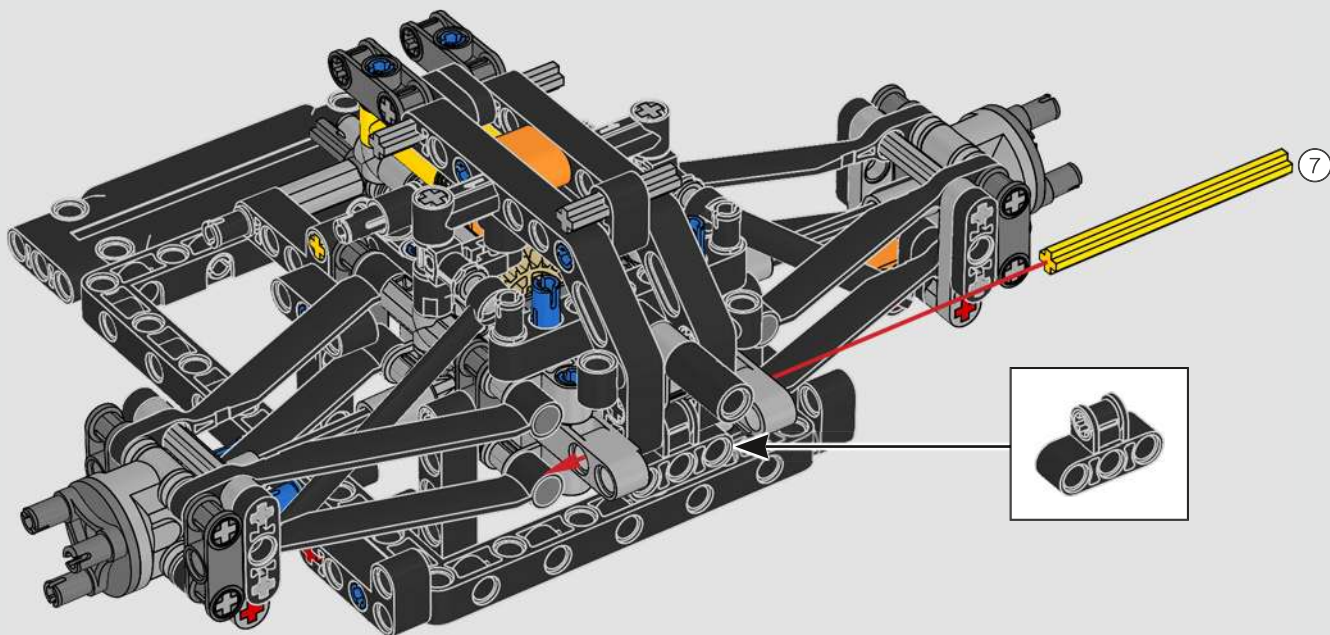

50

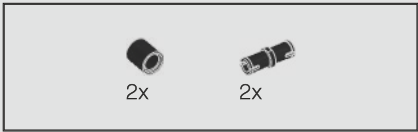

45

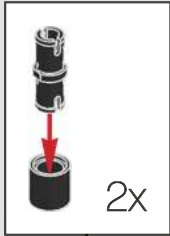
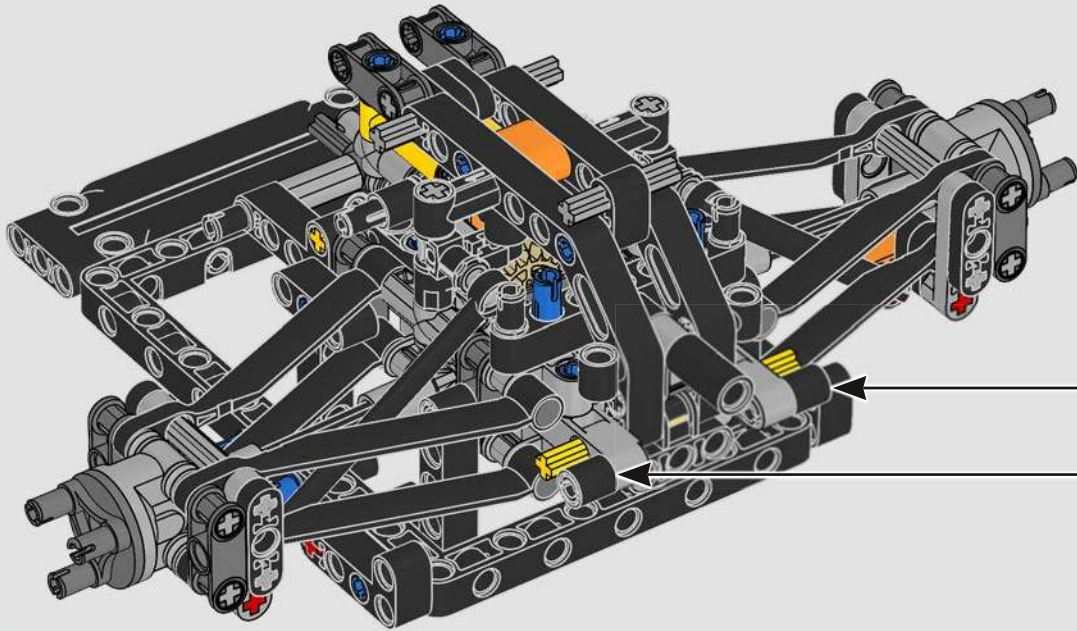



46

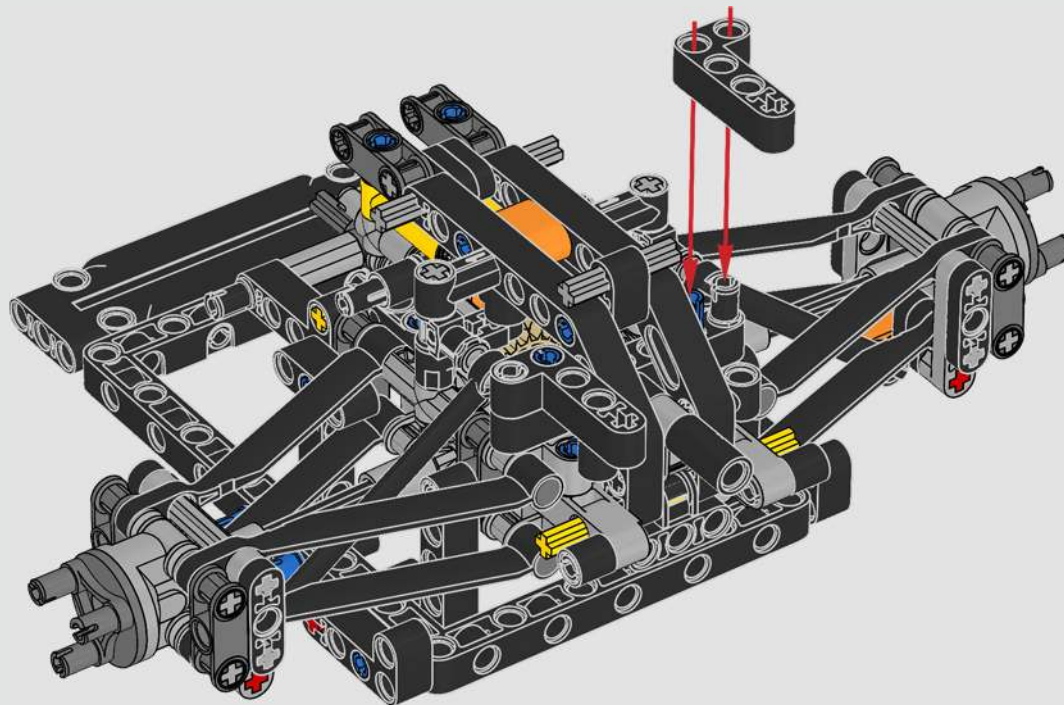

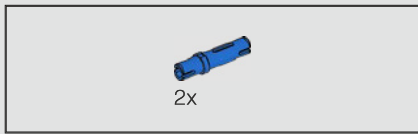

47

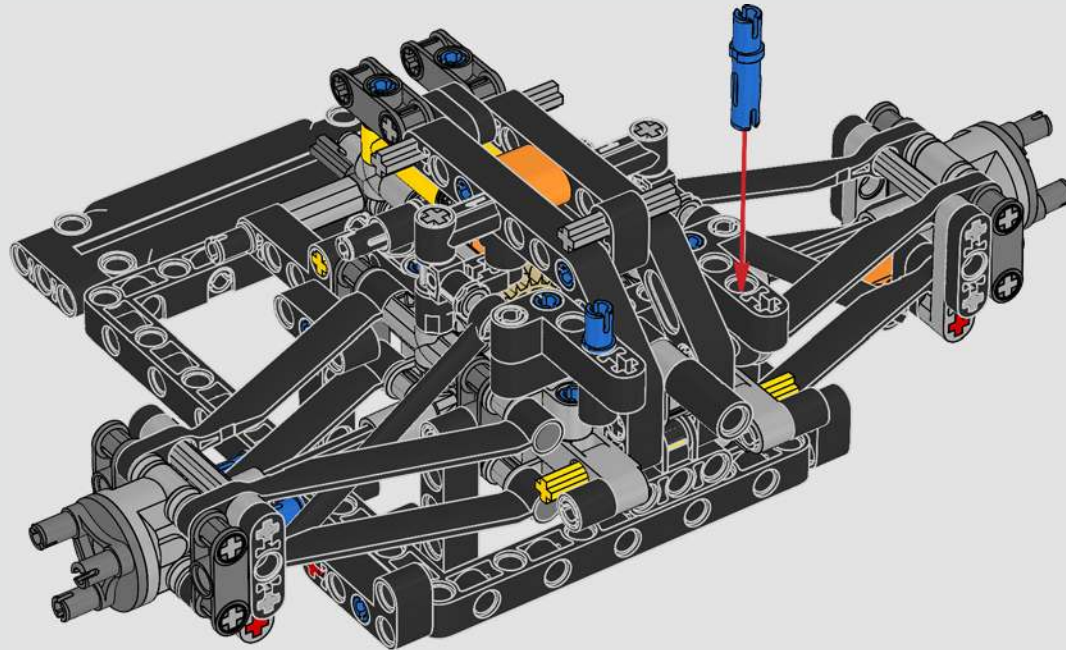

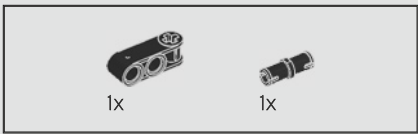

48

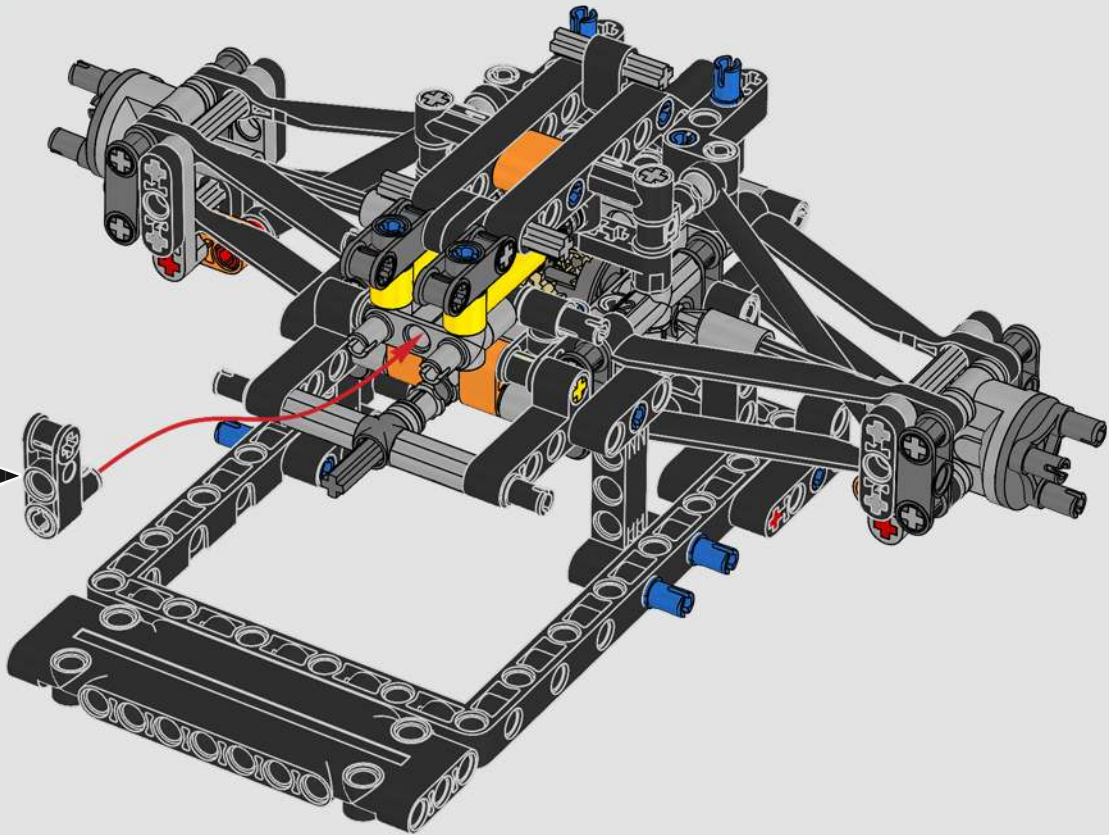
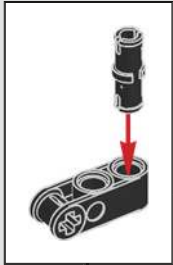

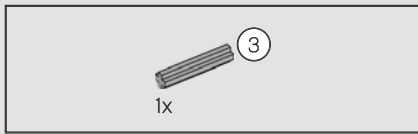

49

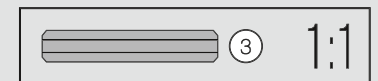
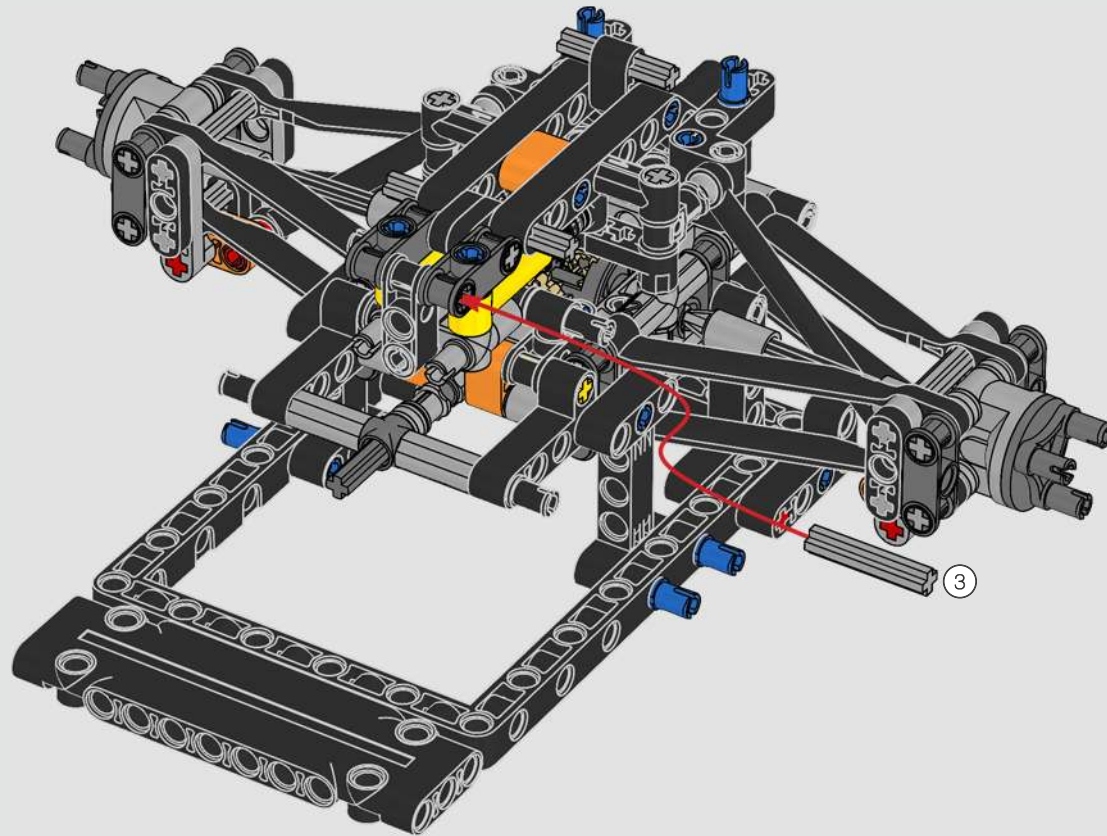

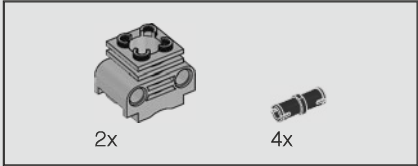

50

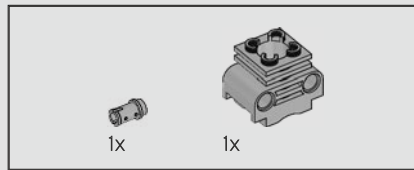
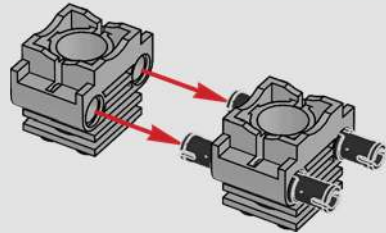

51

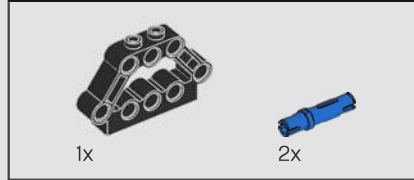
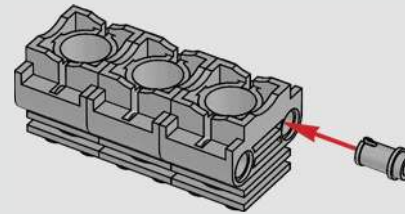

52

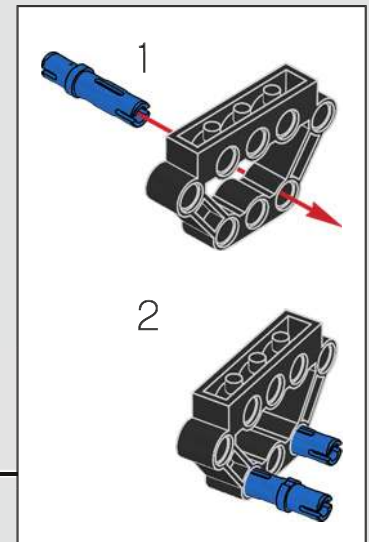
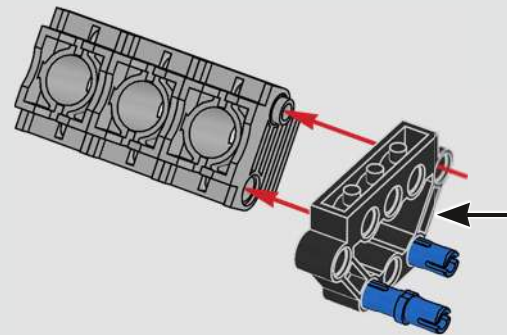

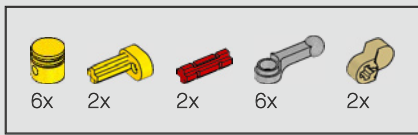

53

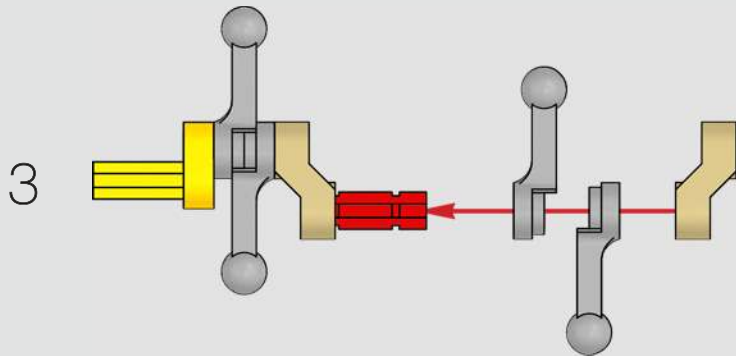
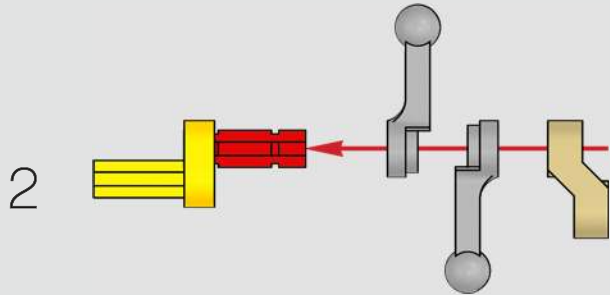
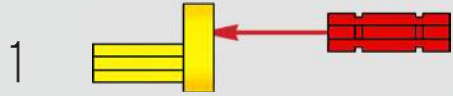

4

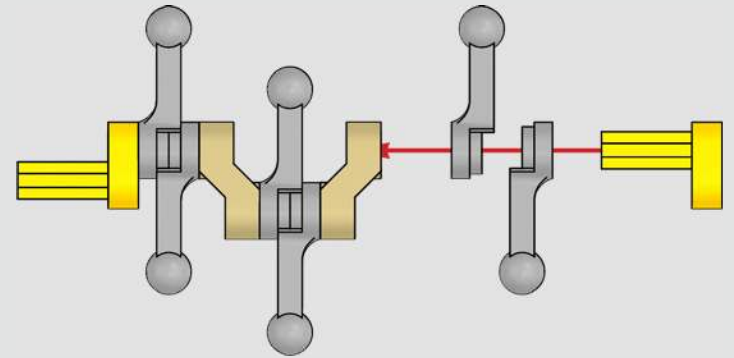

5

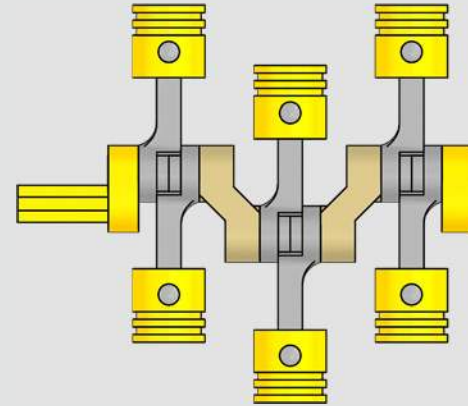

1:1

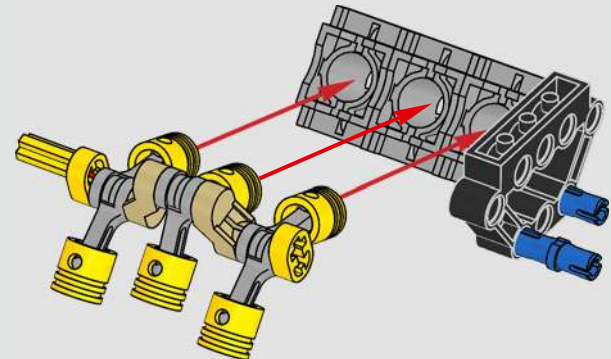

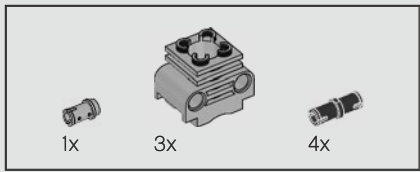

54

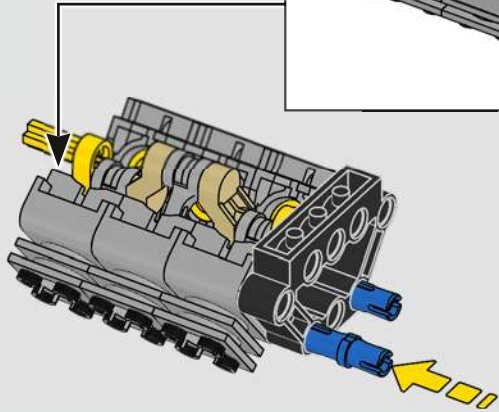
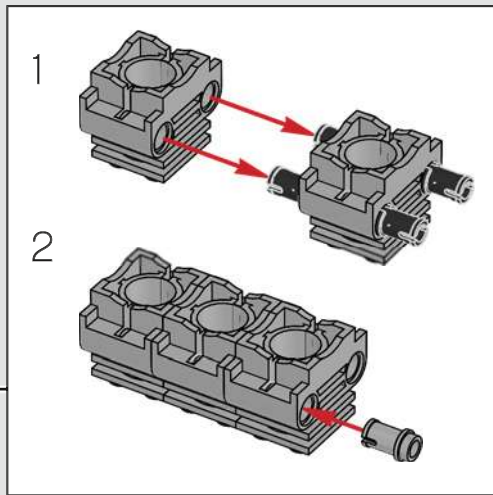

55

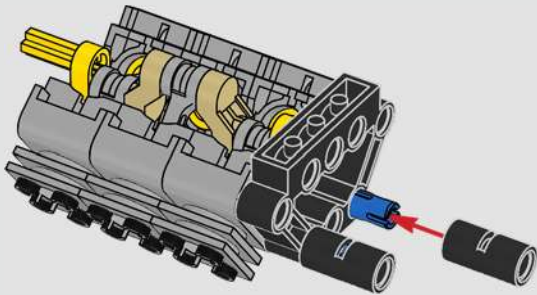

56

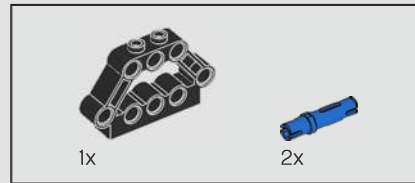
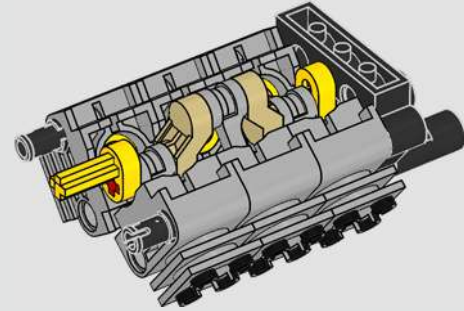

57

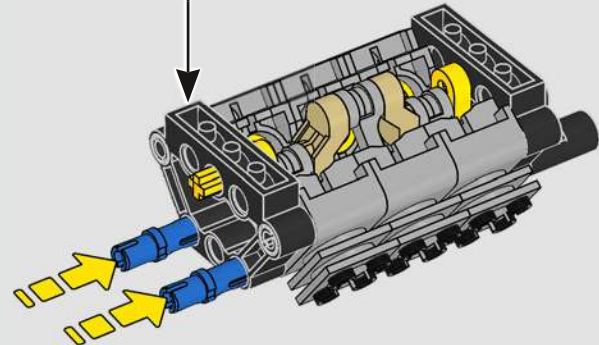
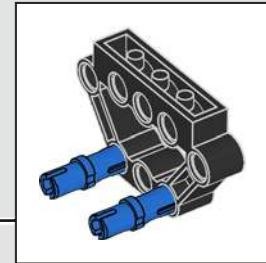

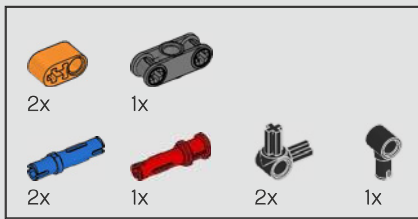

58

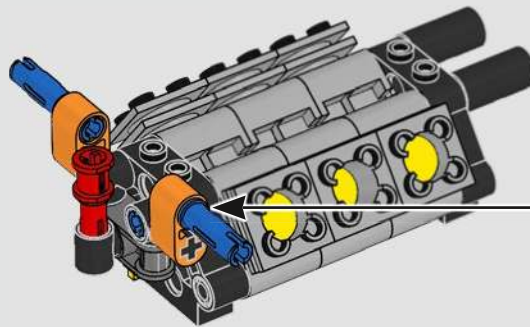
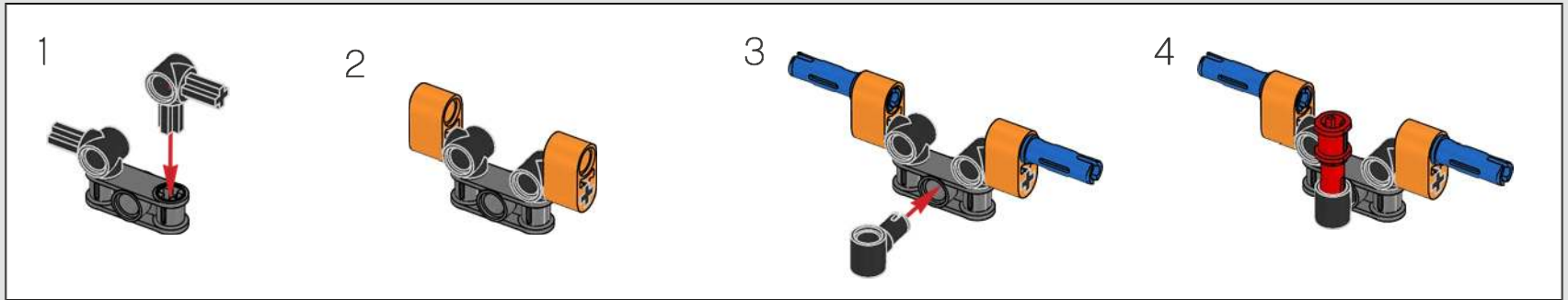

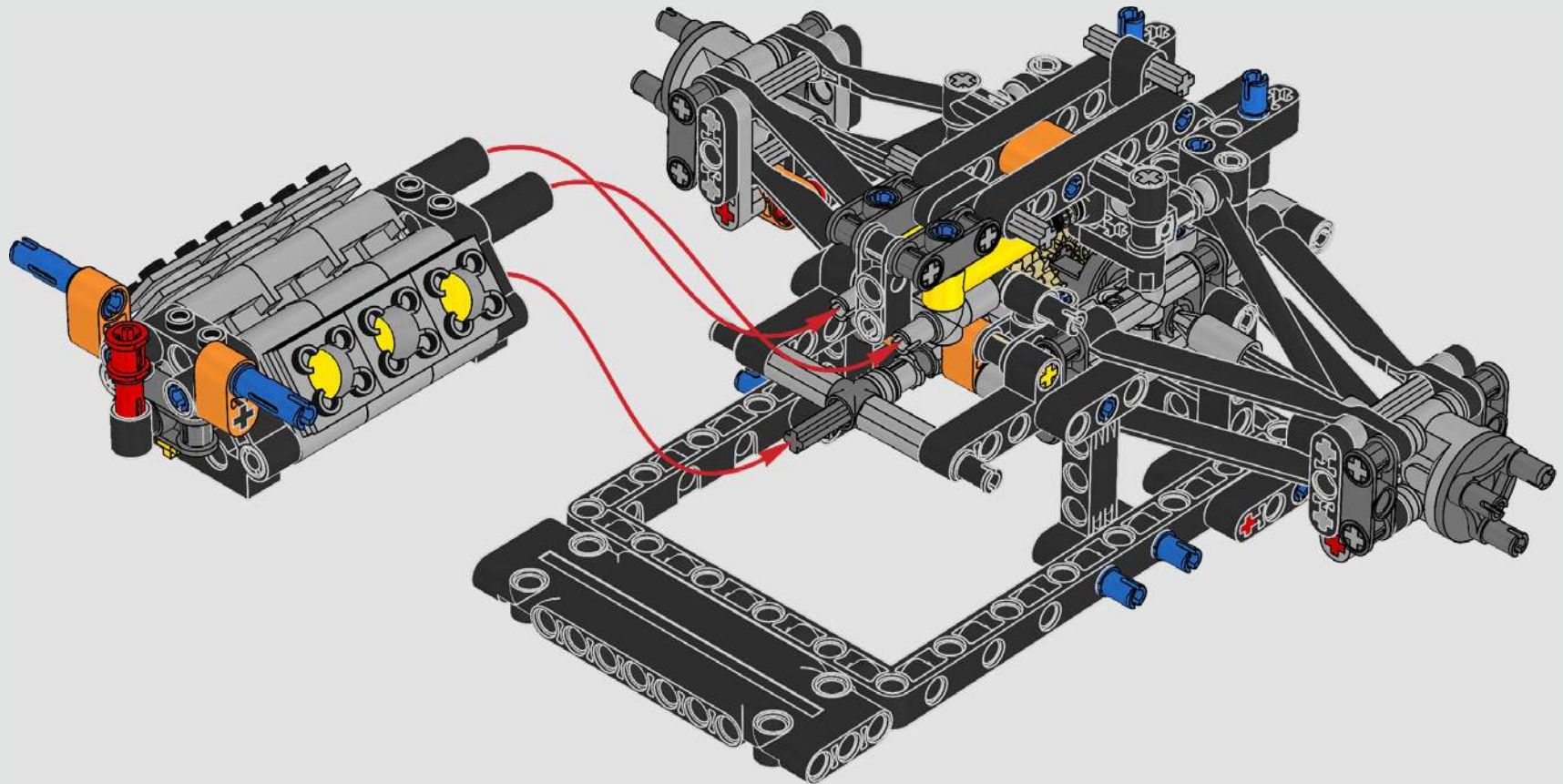

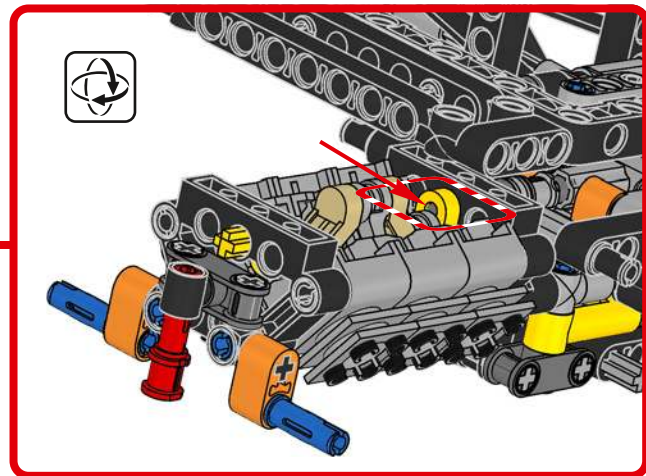
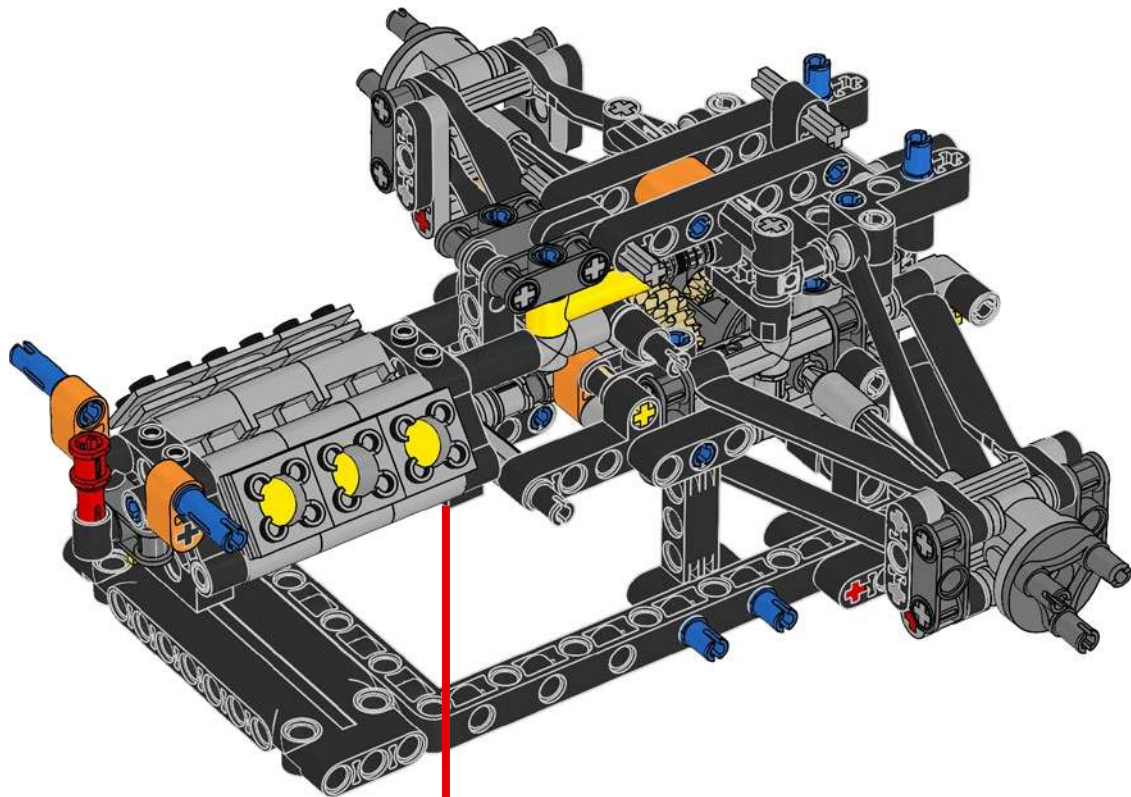

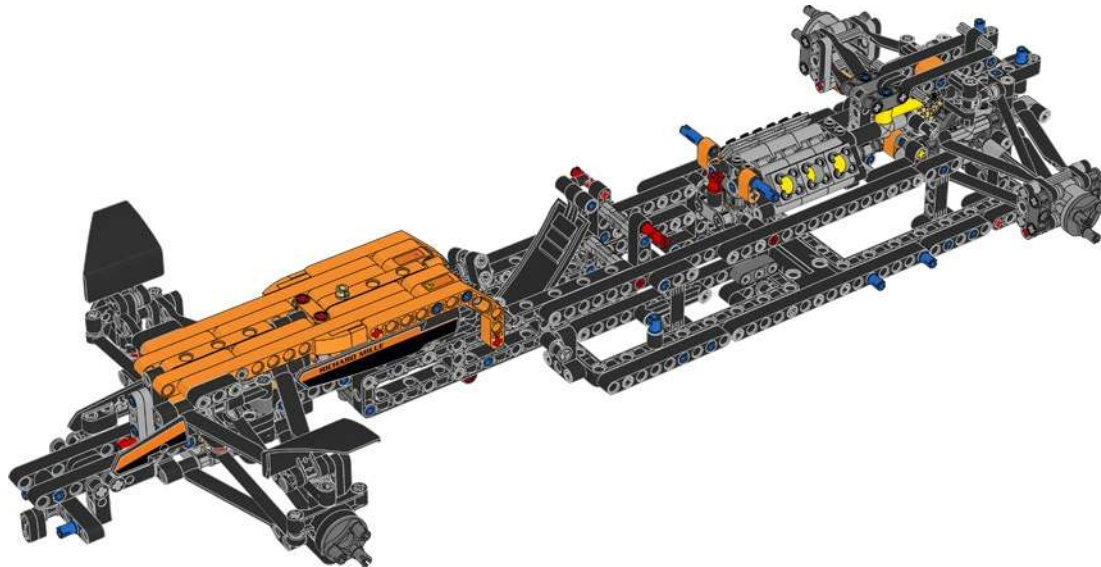
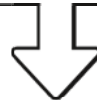
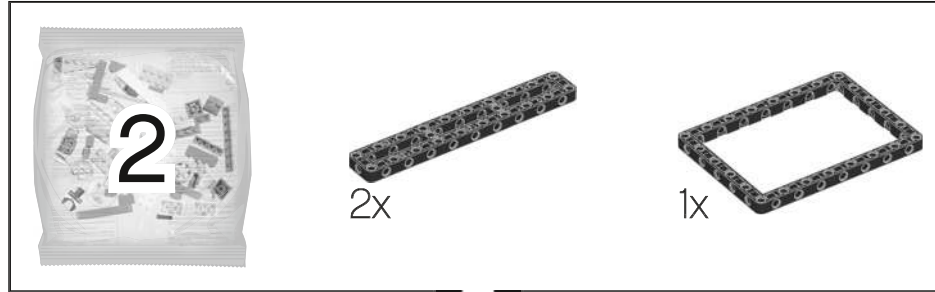

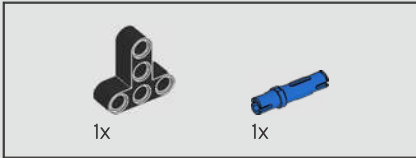
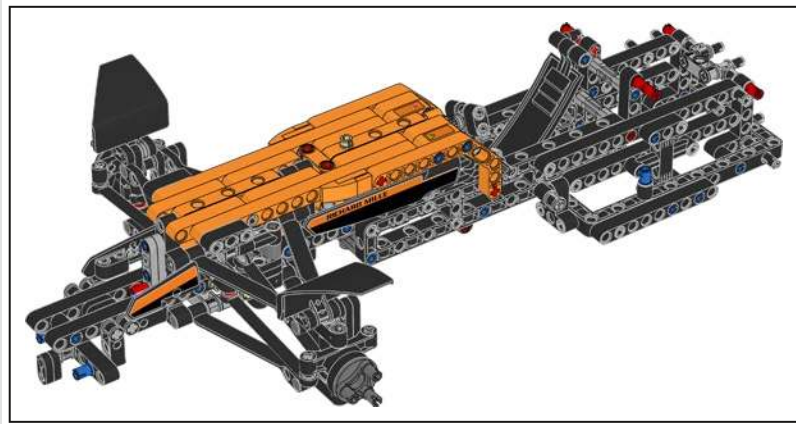

60

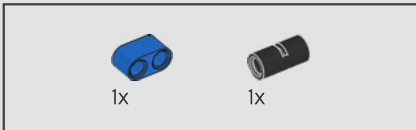
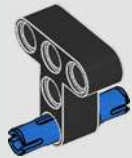

61

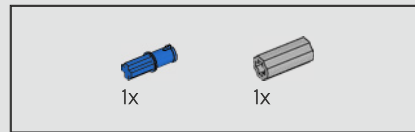
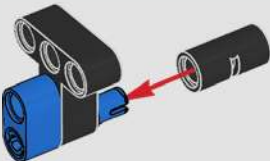

62

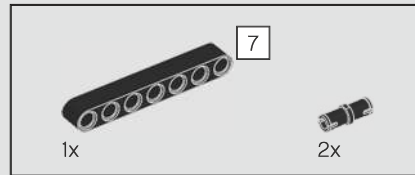
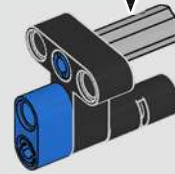
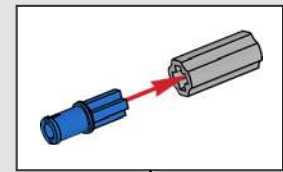

63

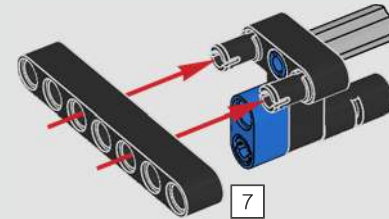

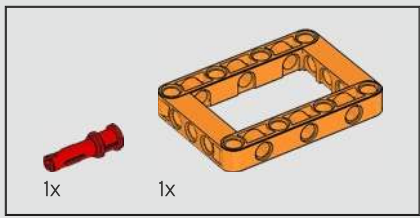

64

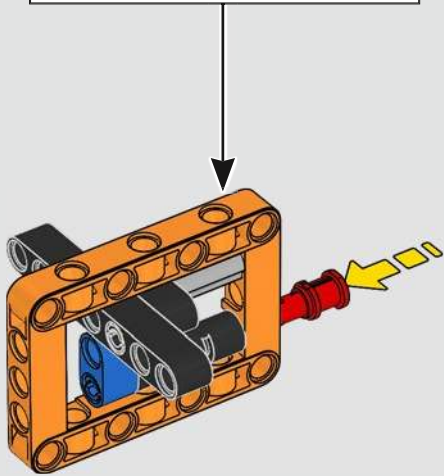
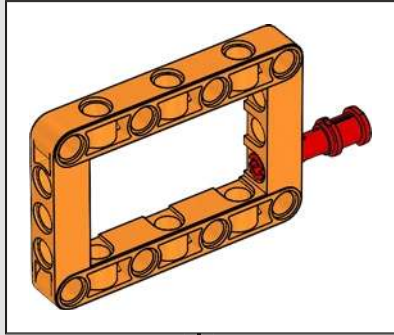

65

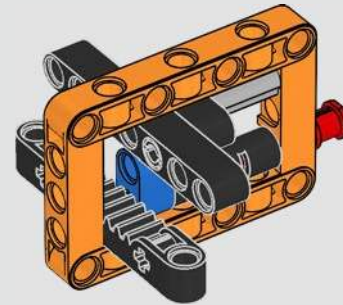

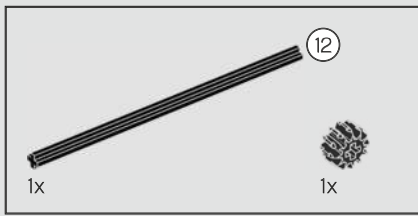

66

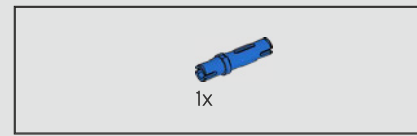
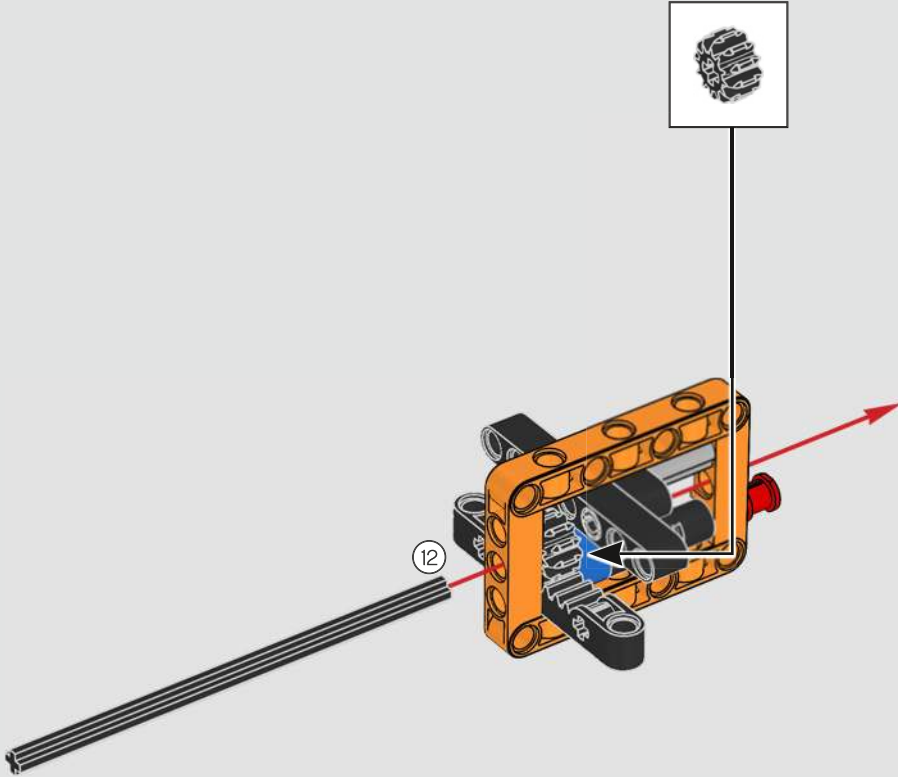

67

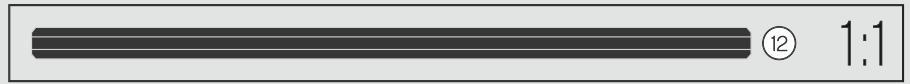
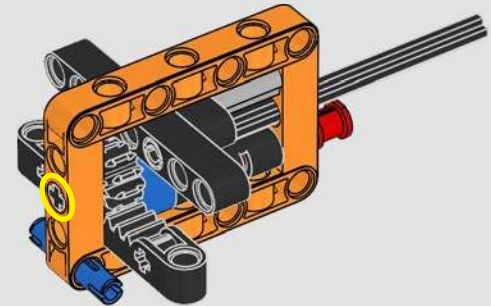

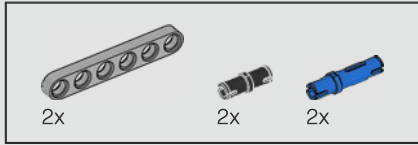
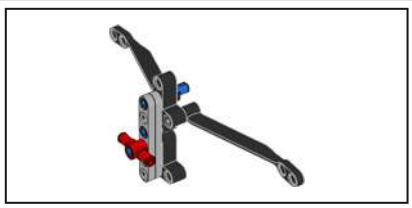

68

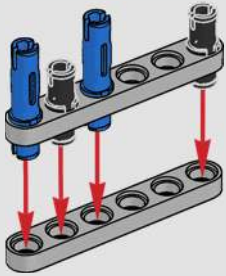

69

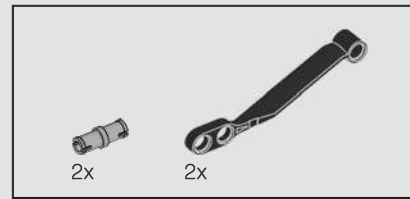
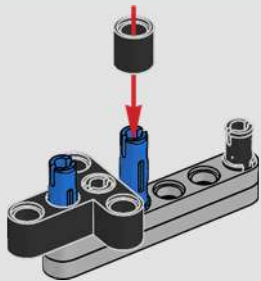

70

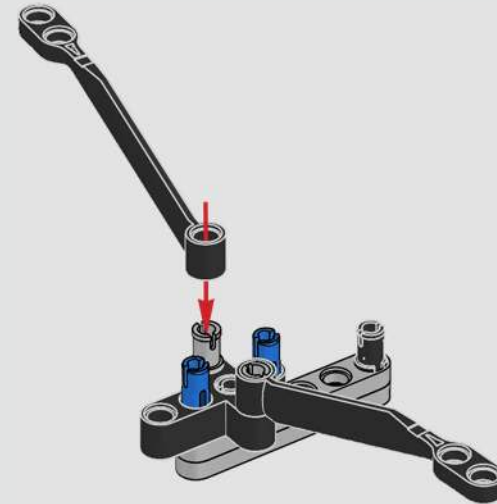

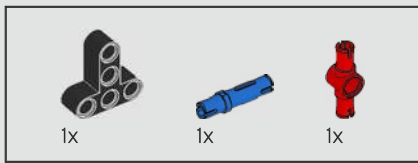

71

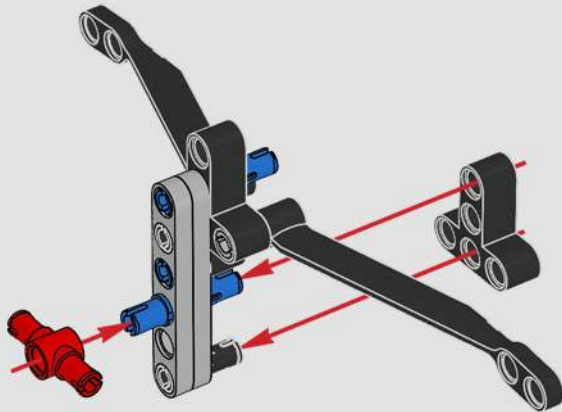

72

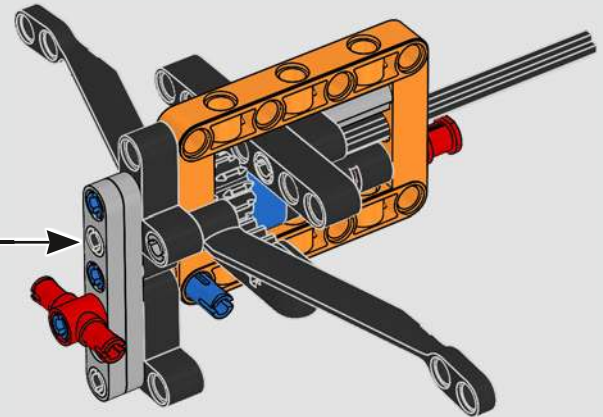

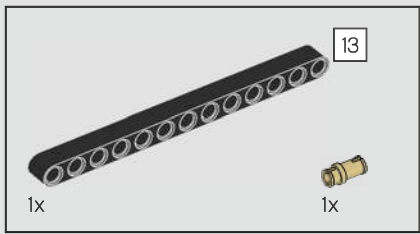

73

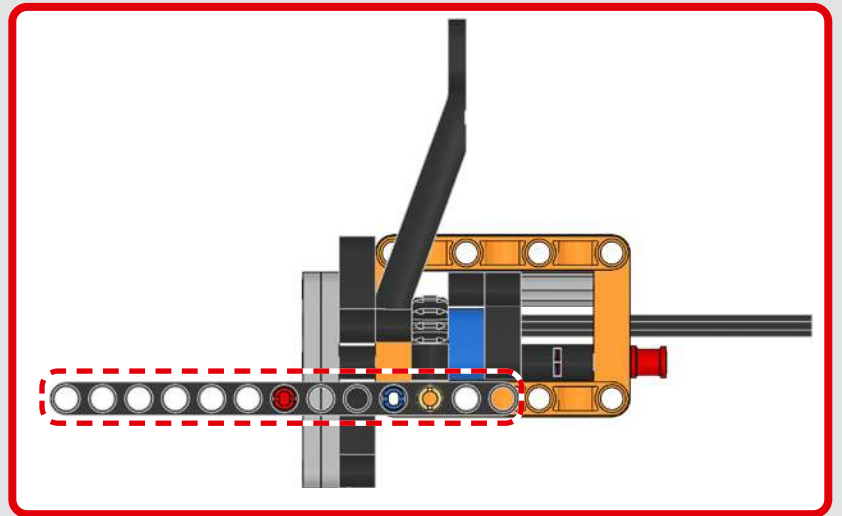
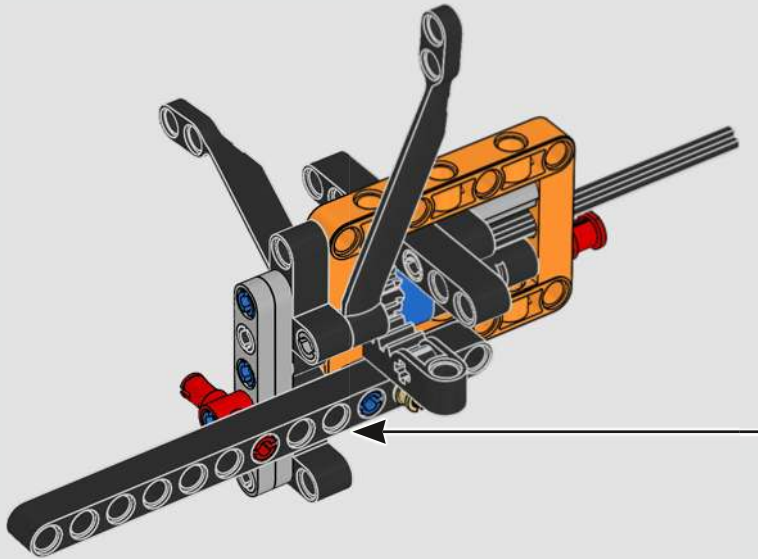
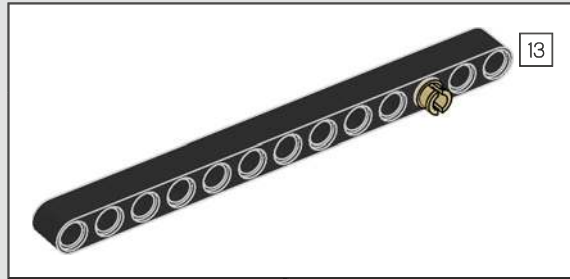

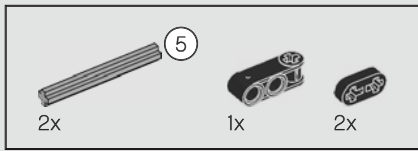

74

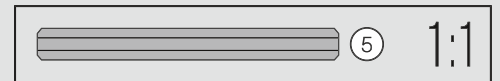
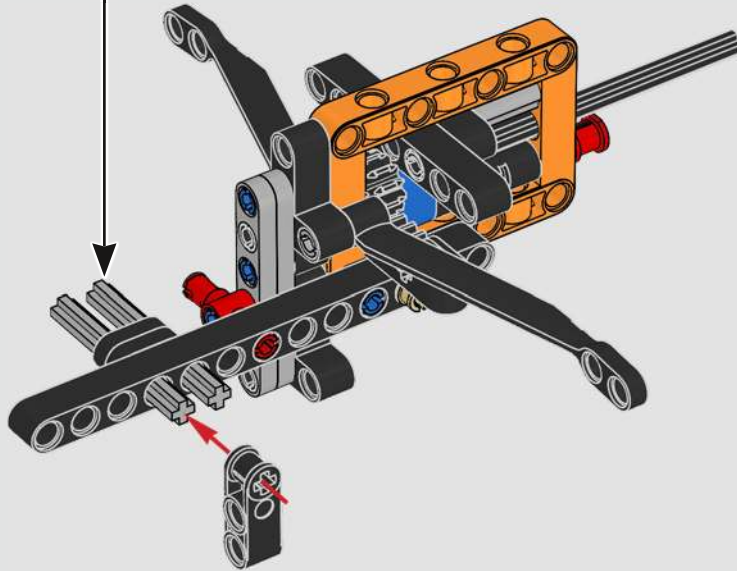
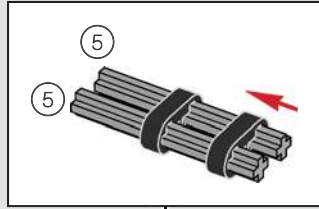

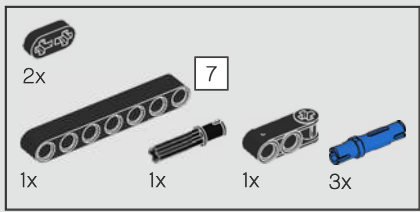

75

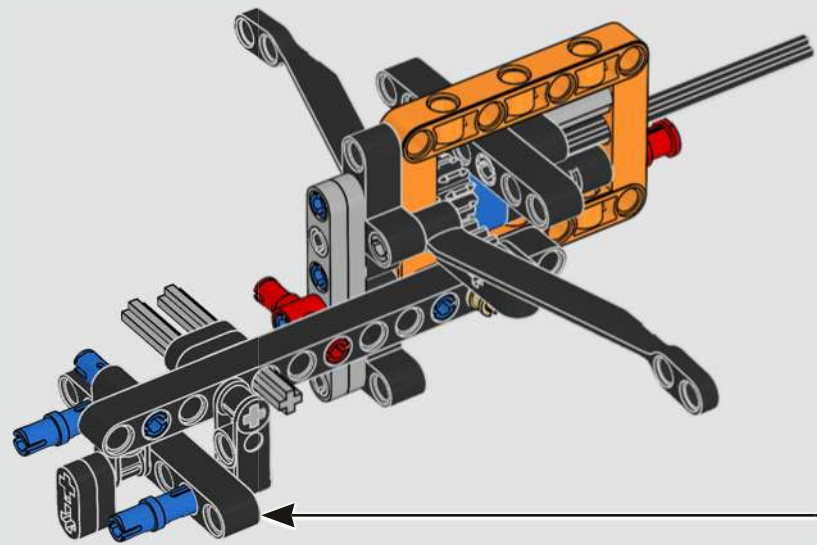
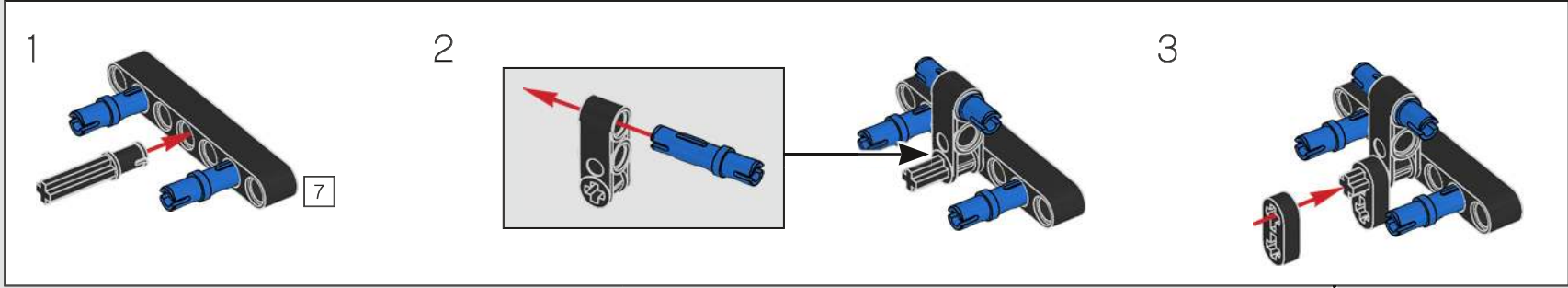

70

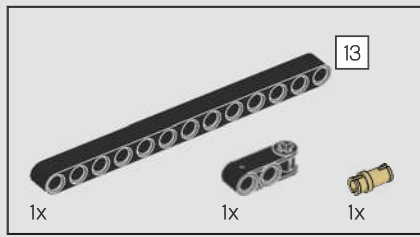

76

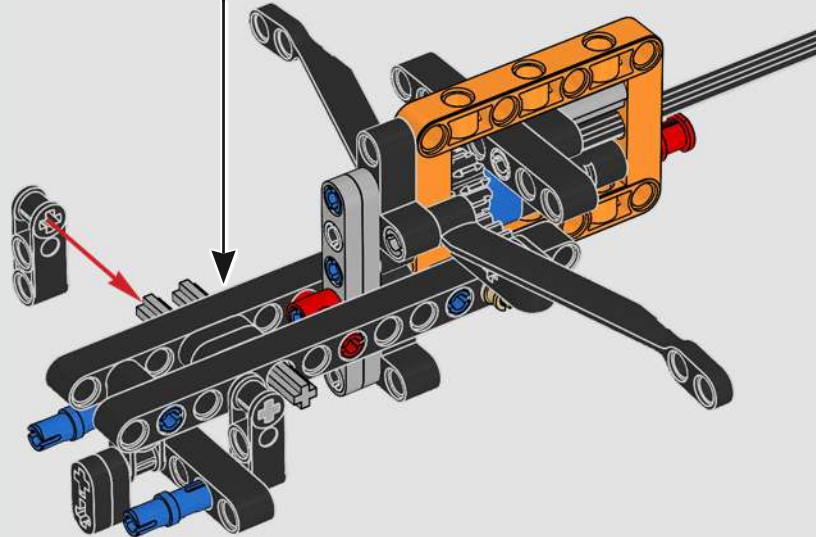
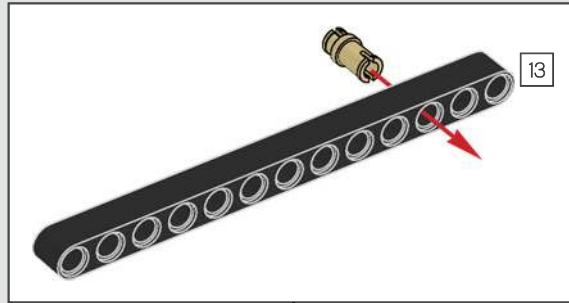

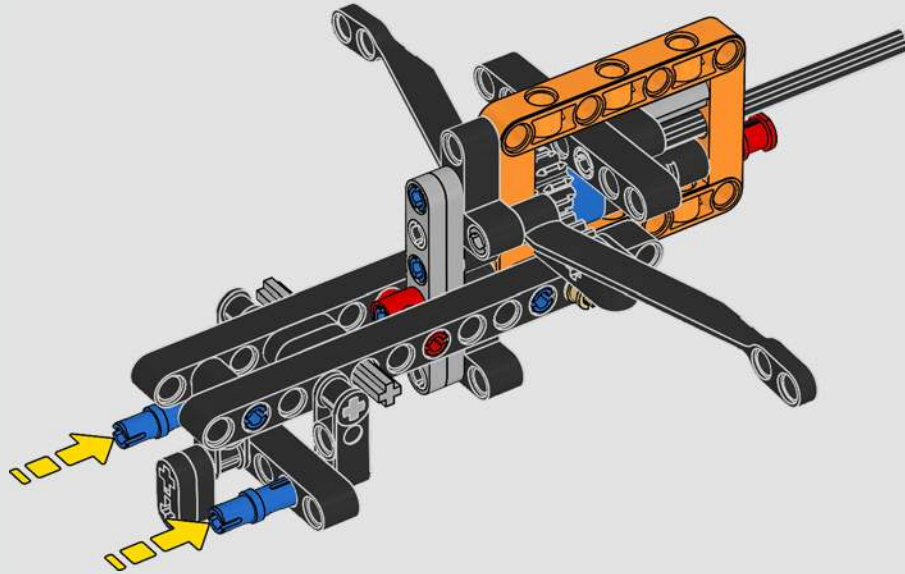

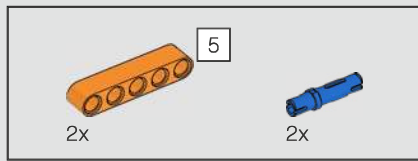

78

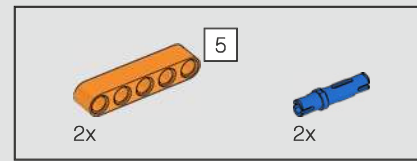
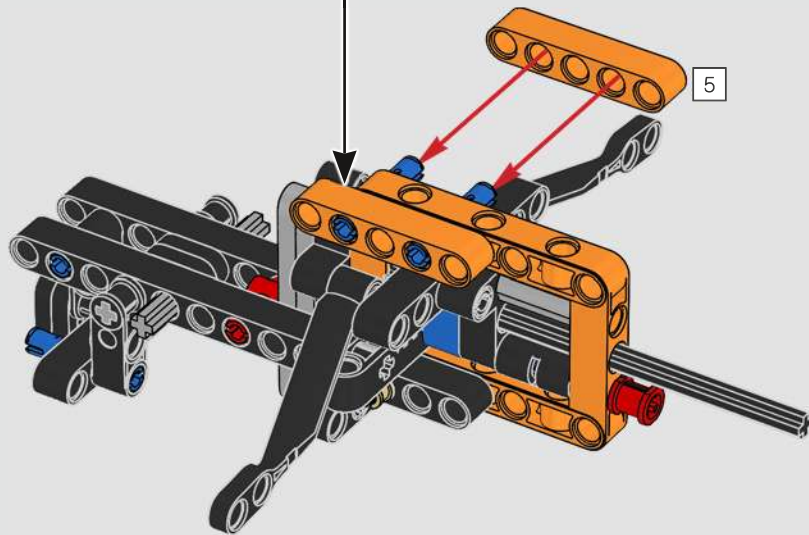
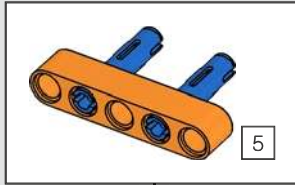

79

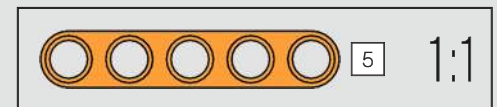
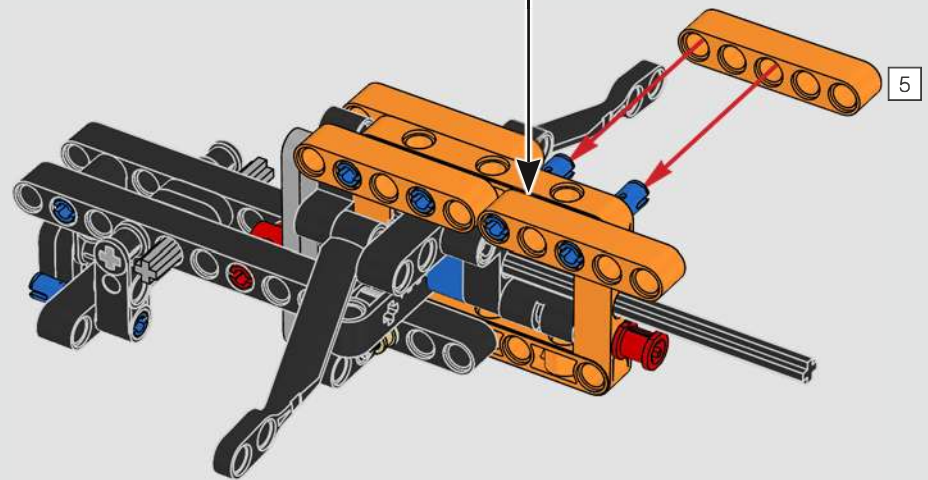
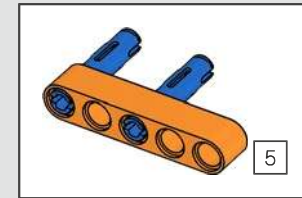

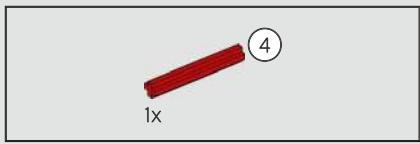

80

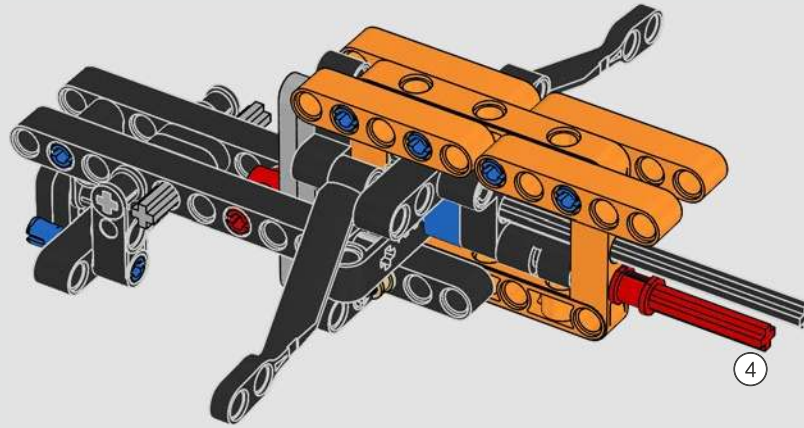

74

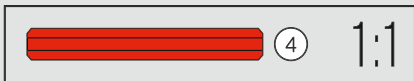

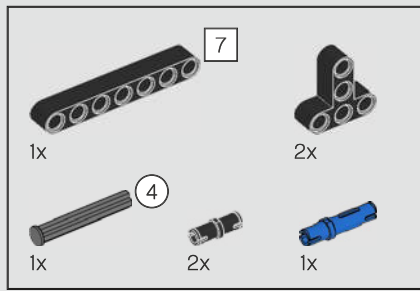

81

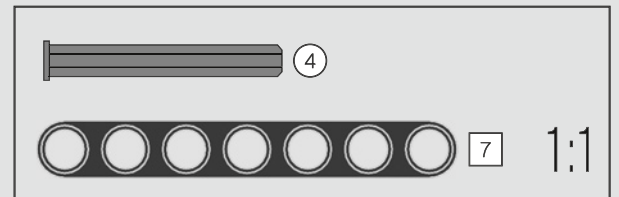
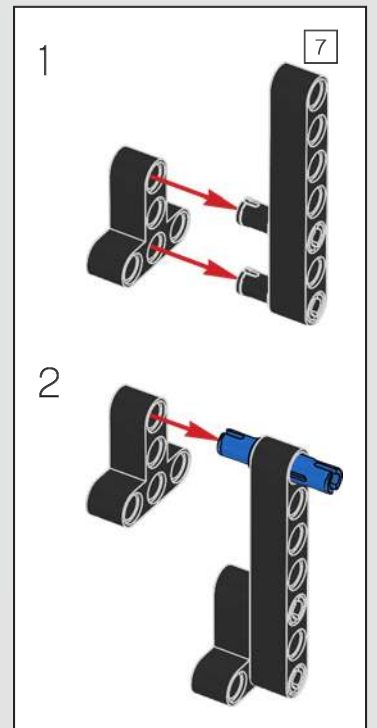
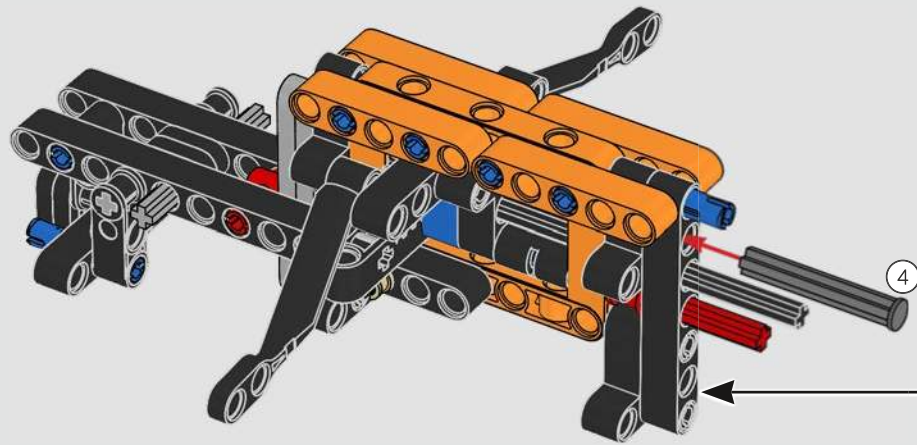

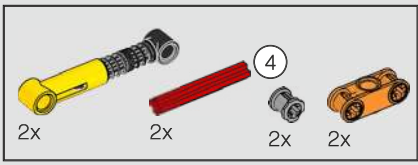

82

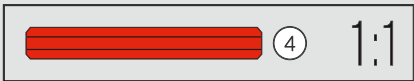
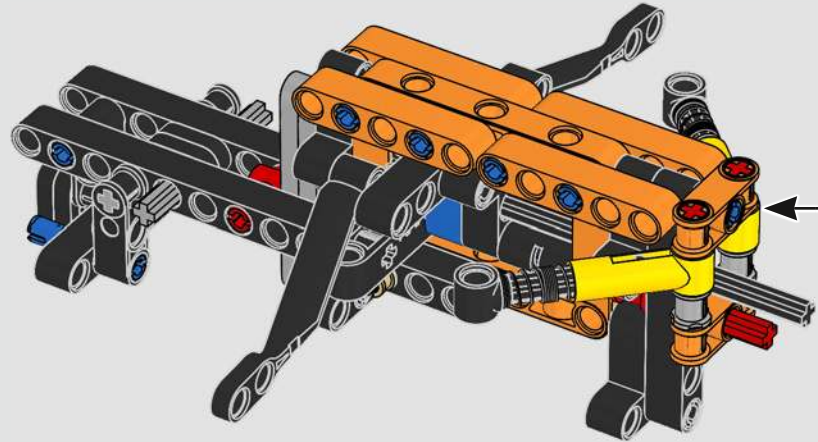
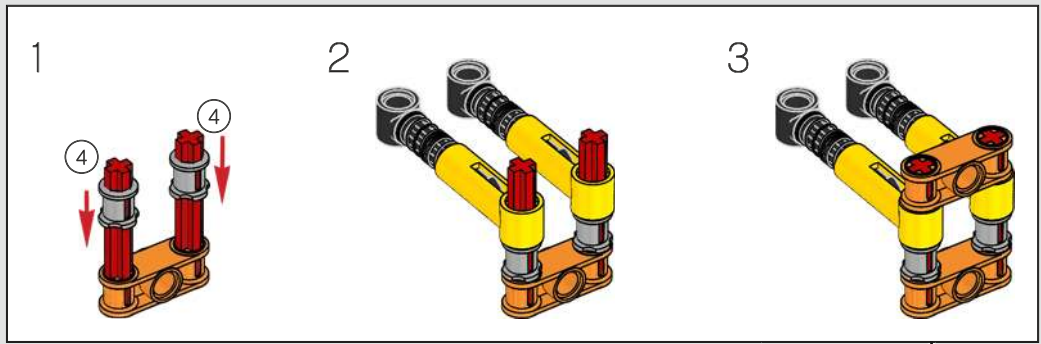

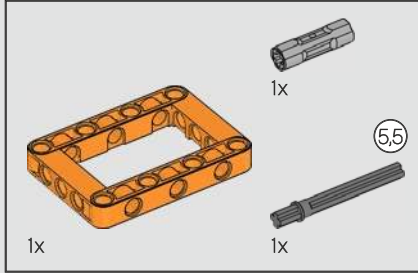
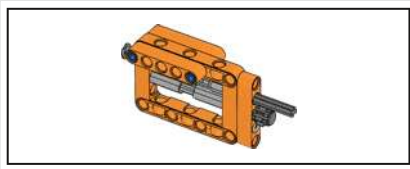

83

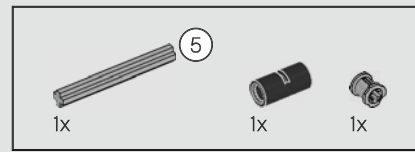
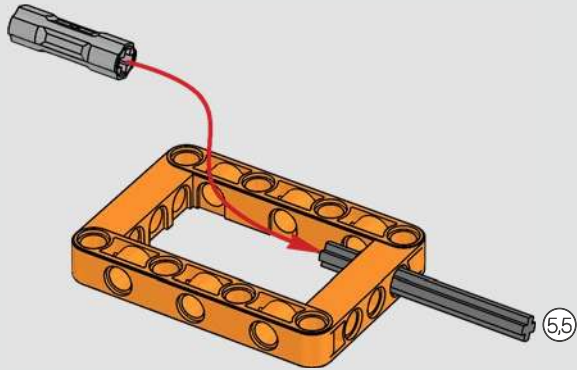

84

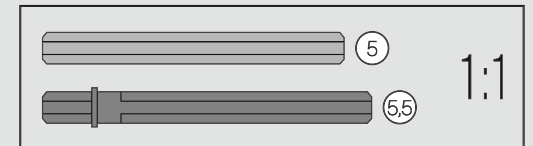
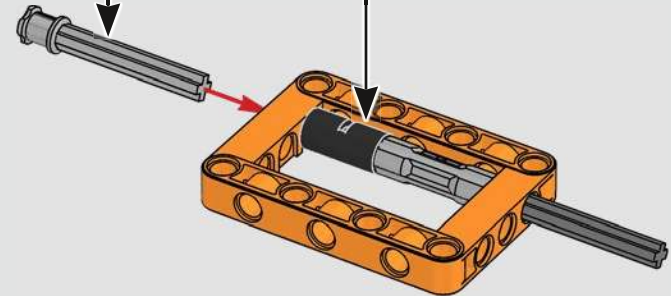
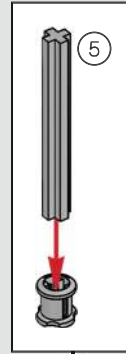

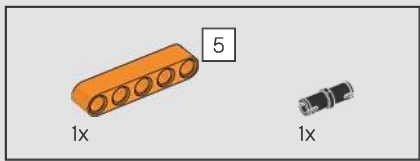

85

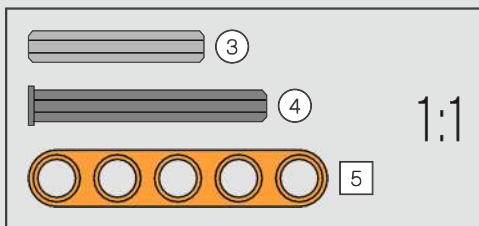
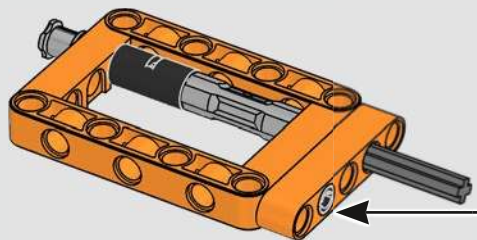
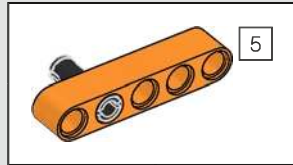

78

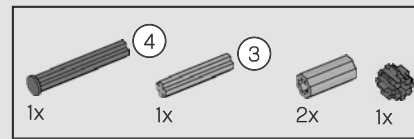

86

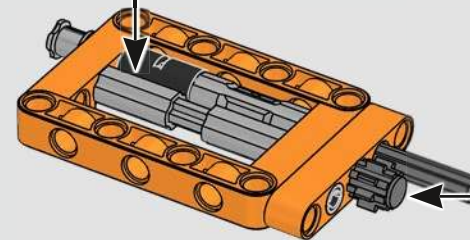
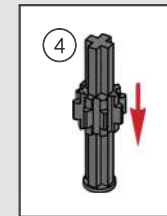
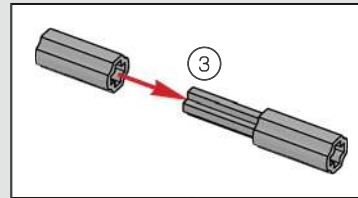

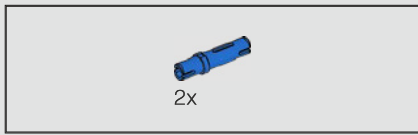

87

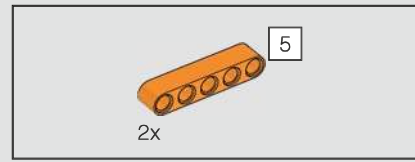
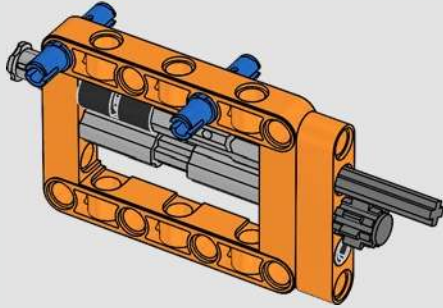

88

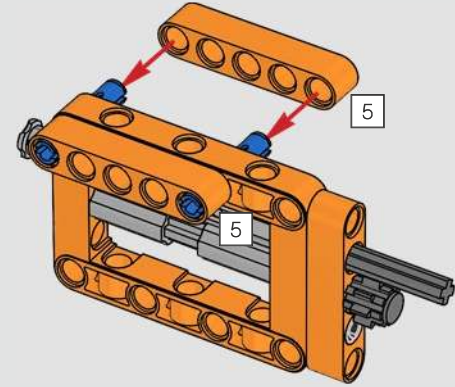

89

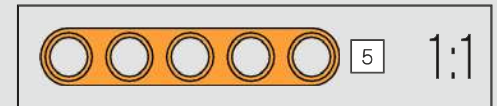
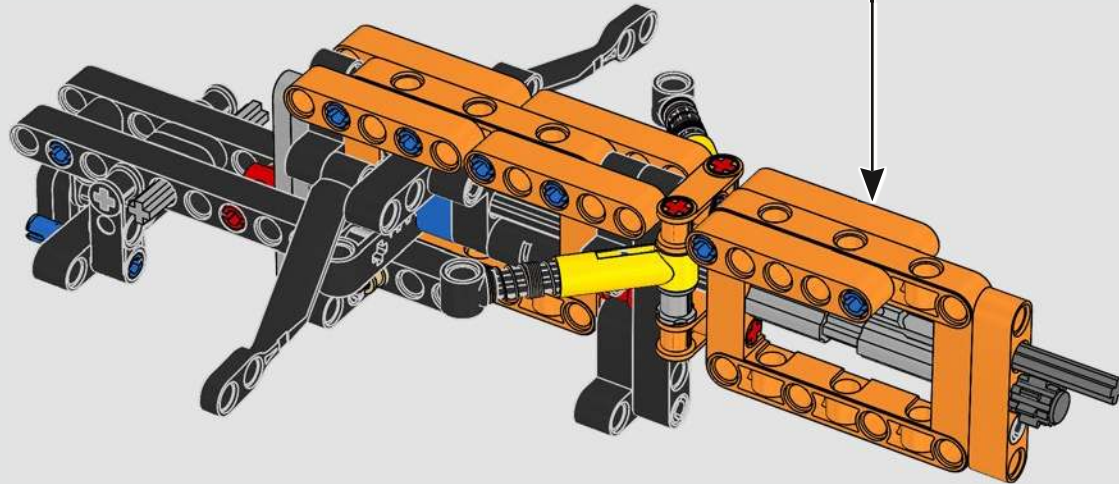

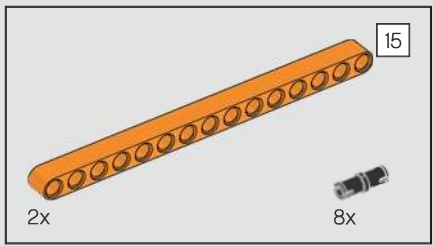

90

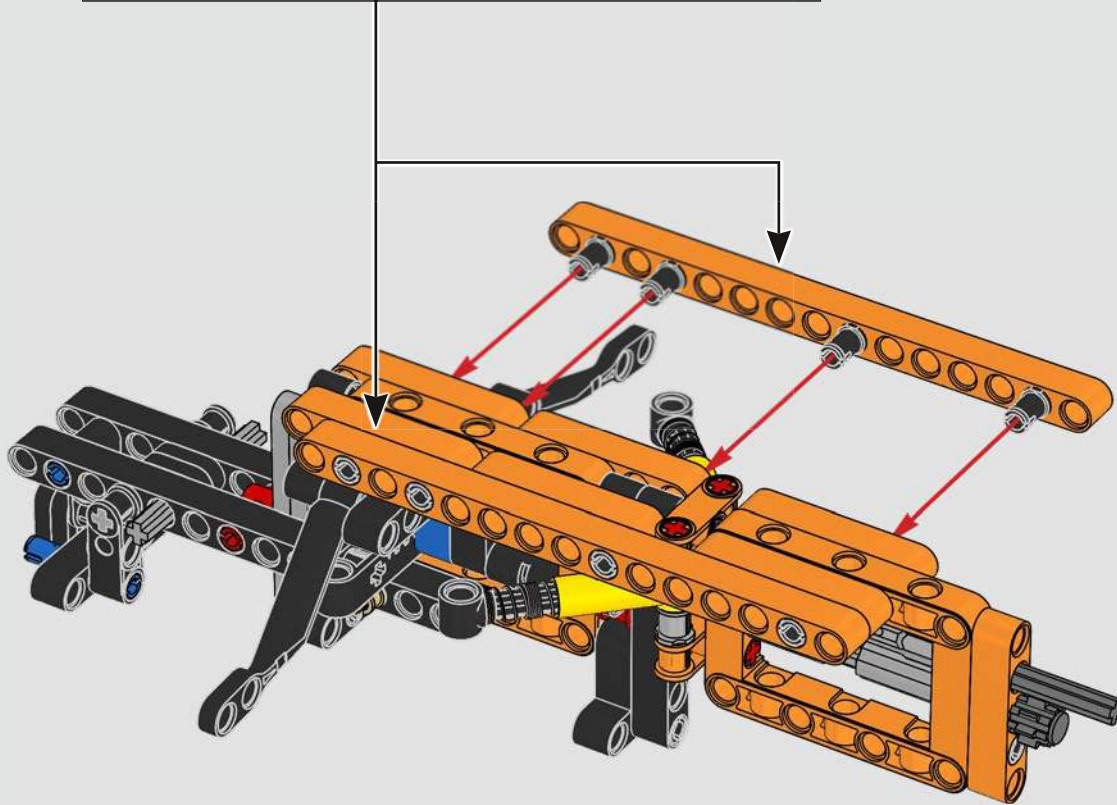
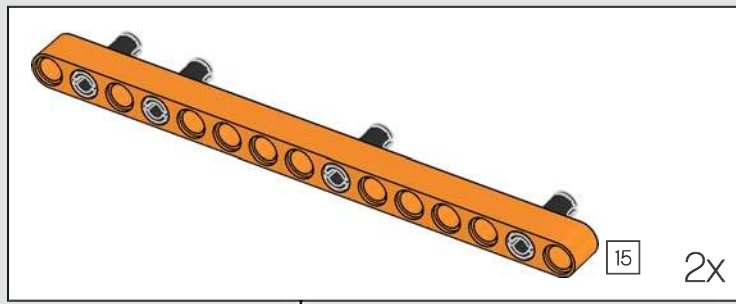

80

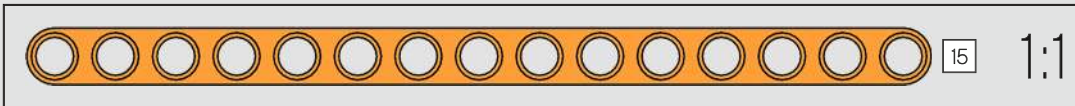

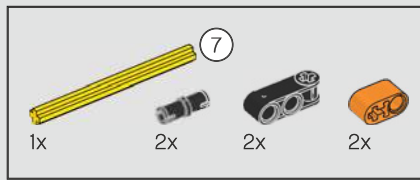

91

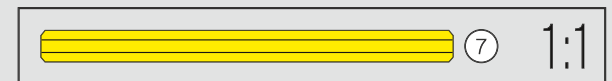
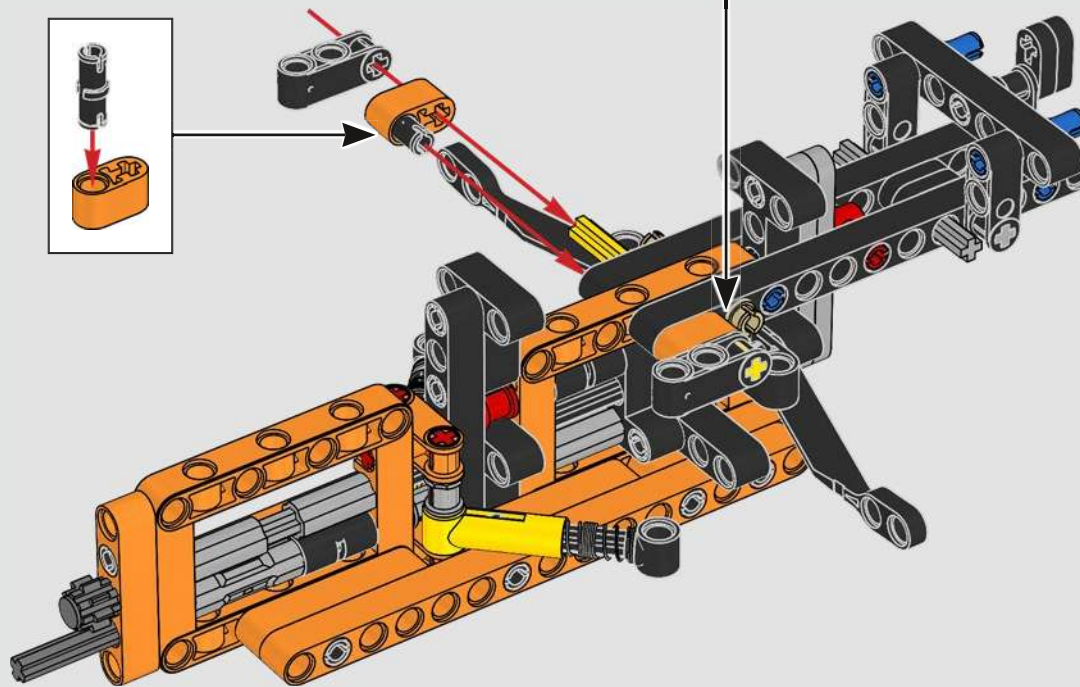
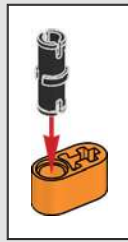
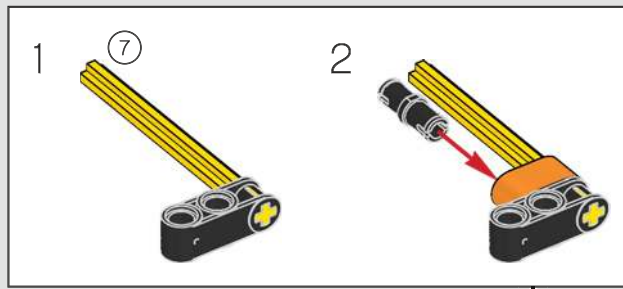

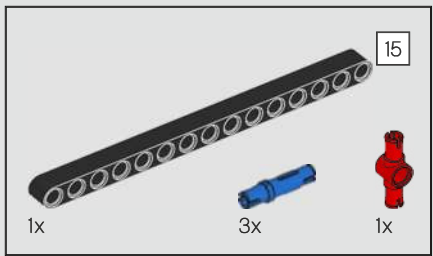

92

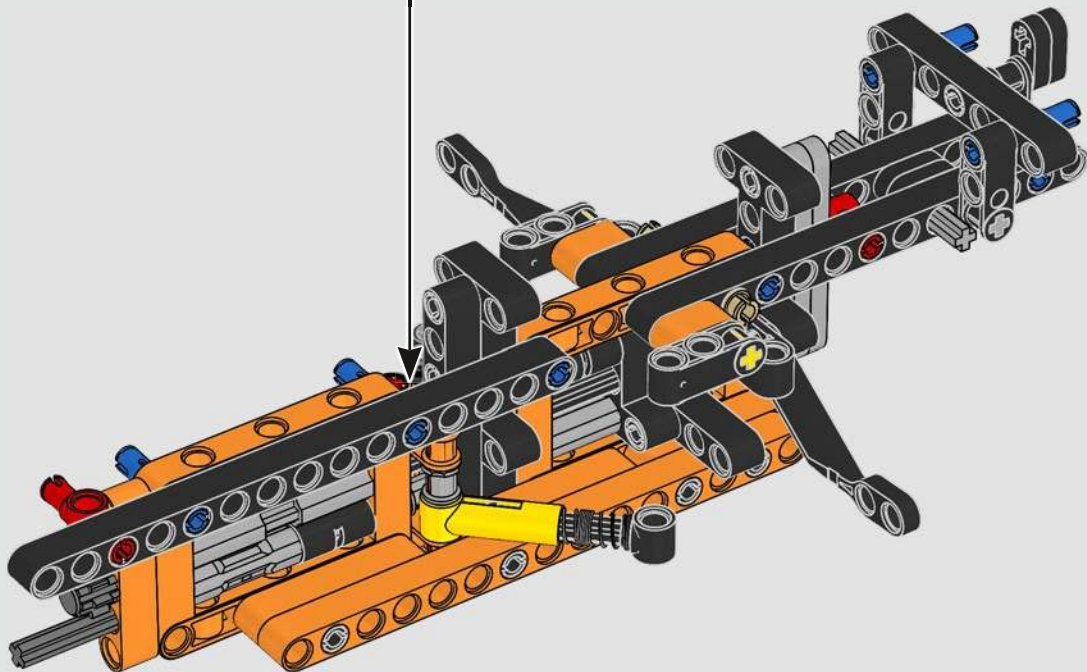
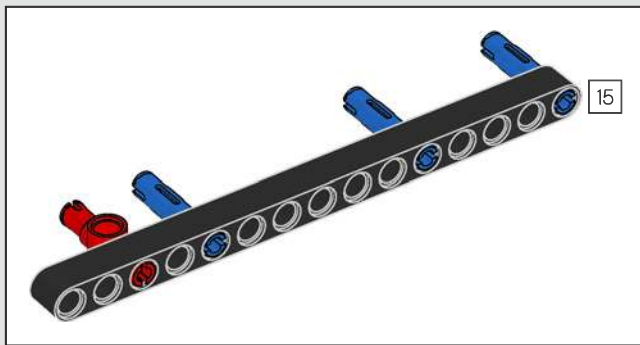

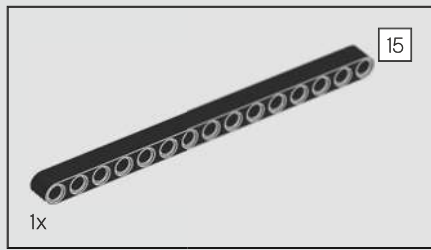

93

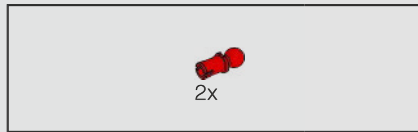
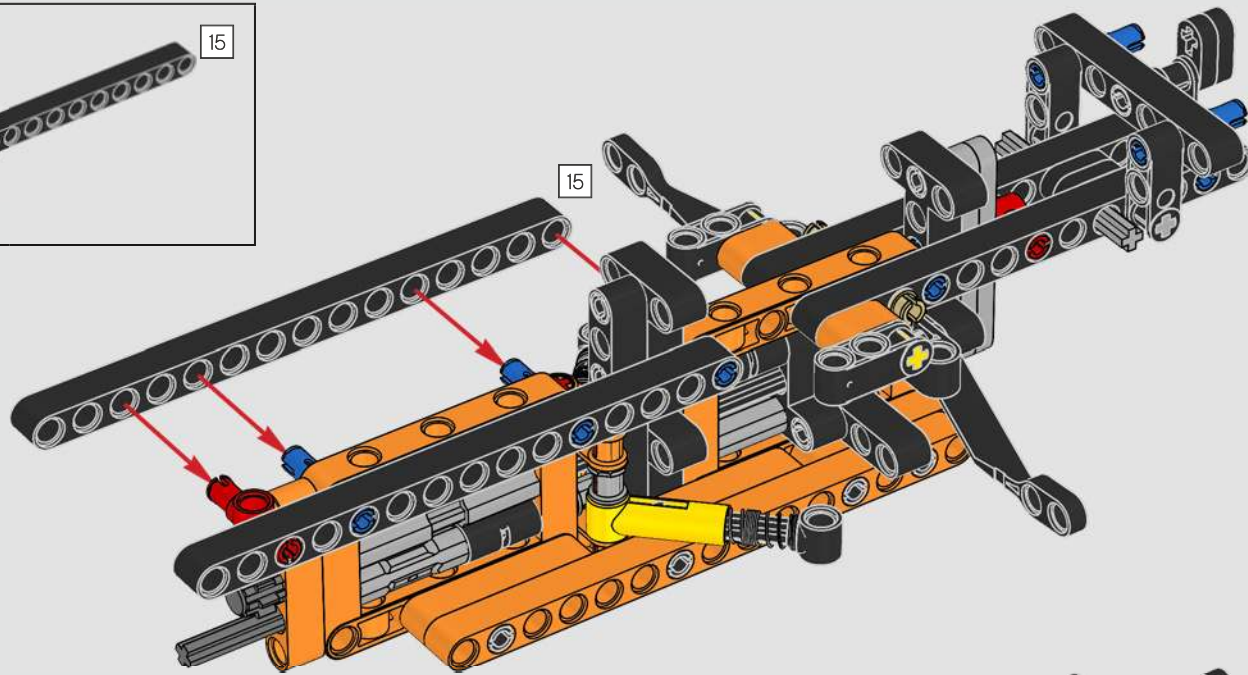

94

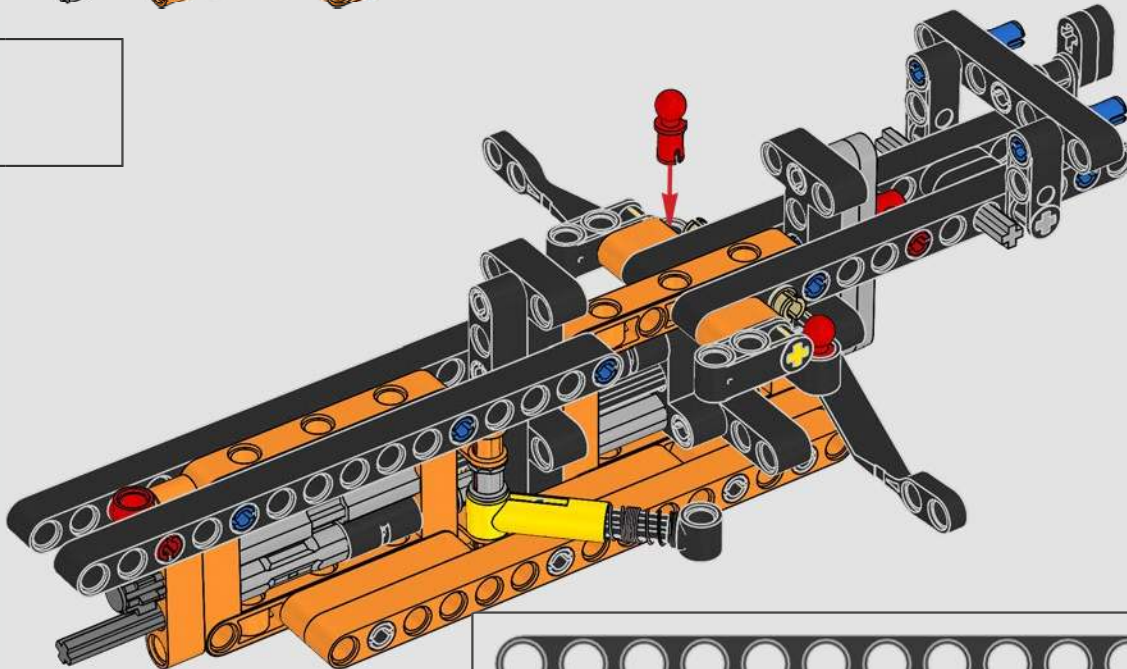

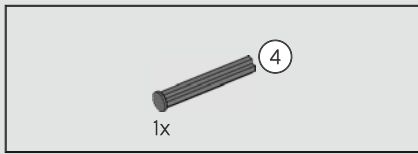

96

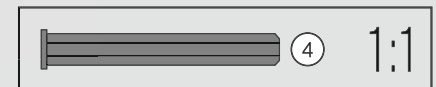
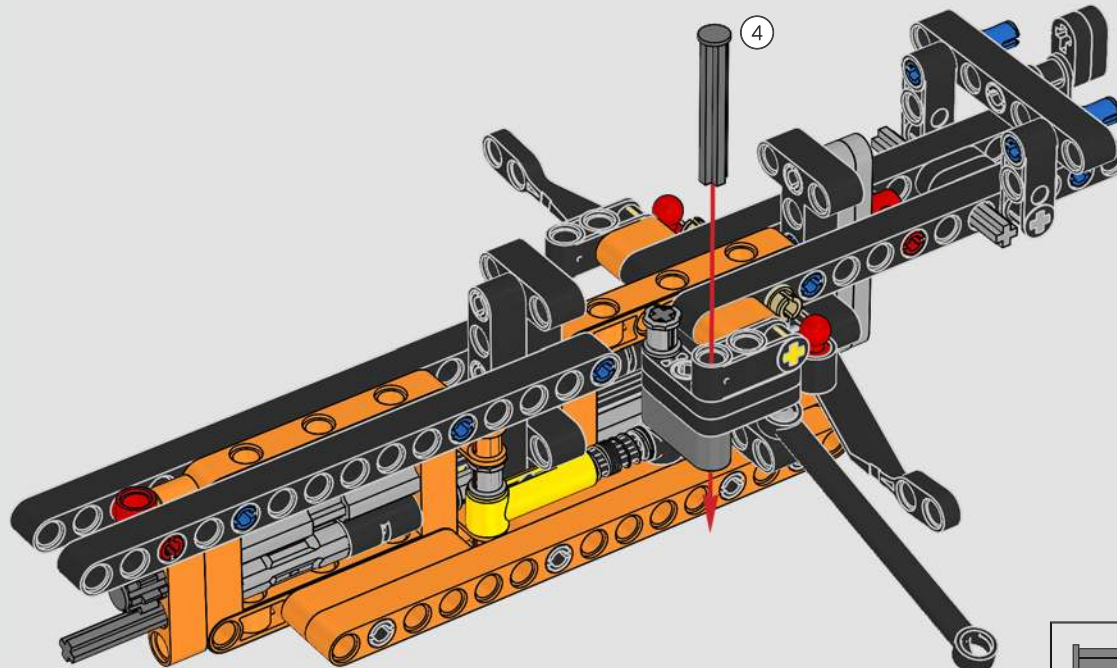
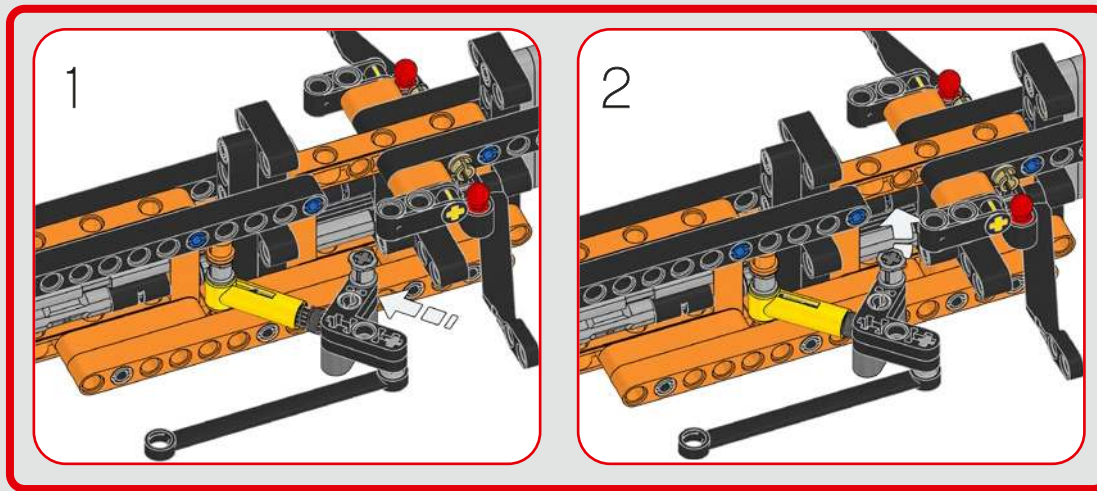

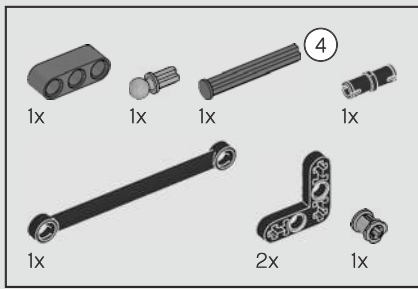

97

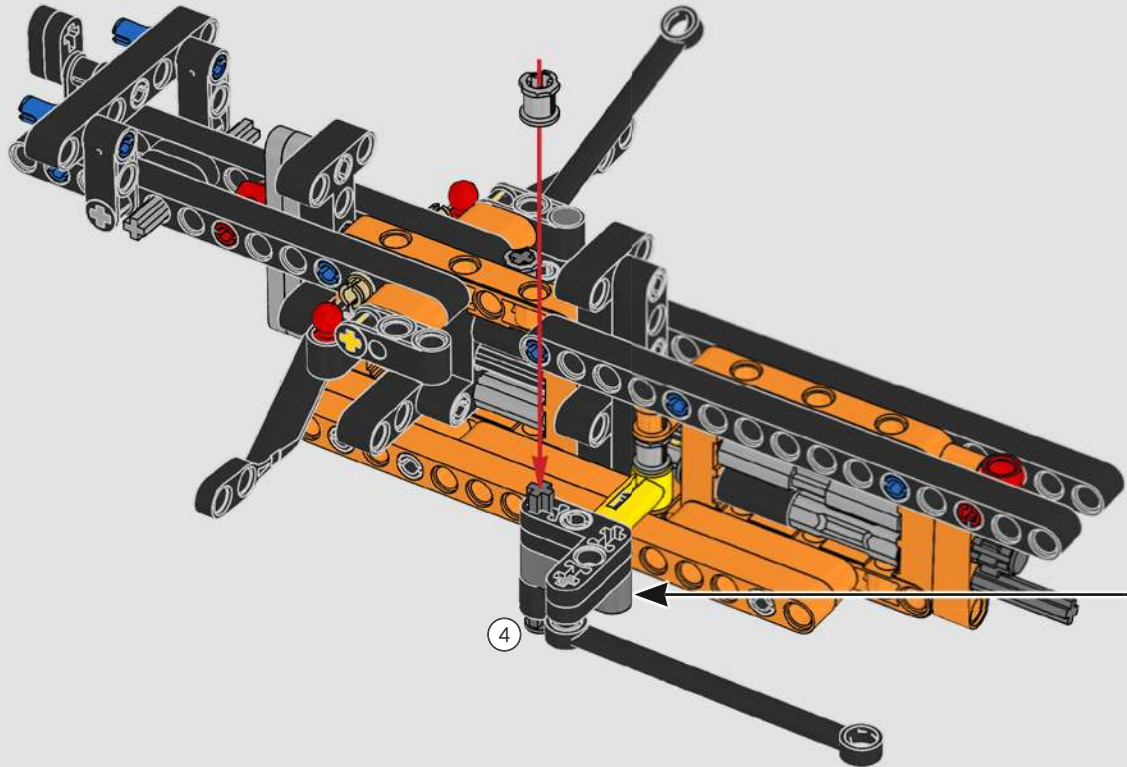
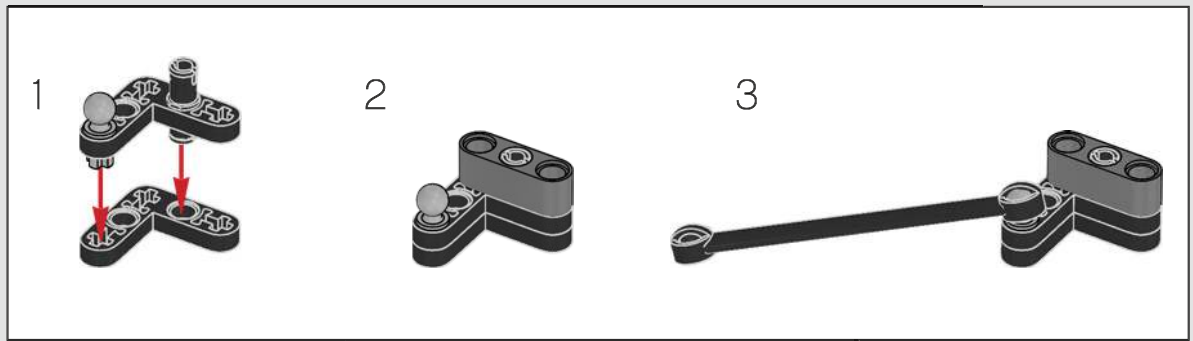

4

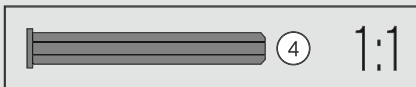

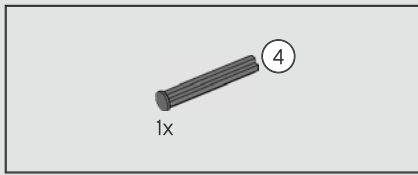

98

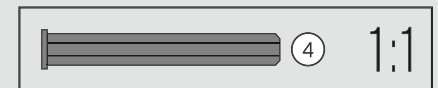
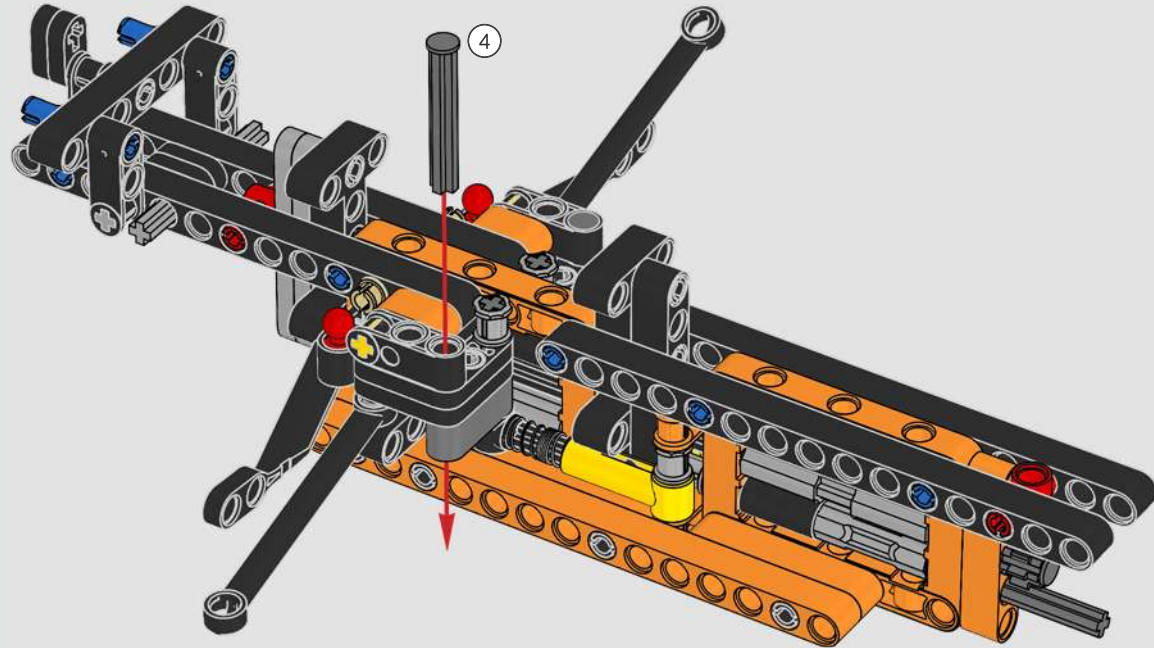
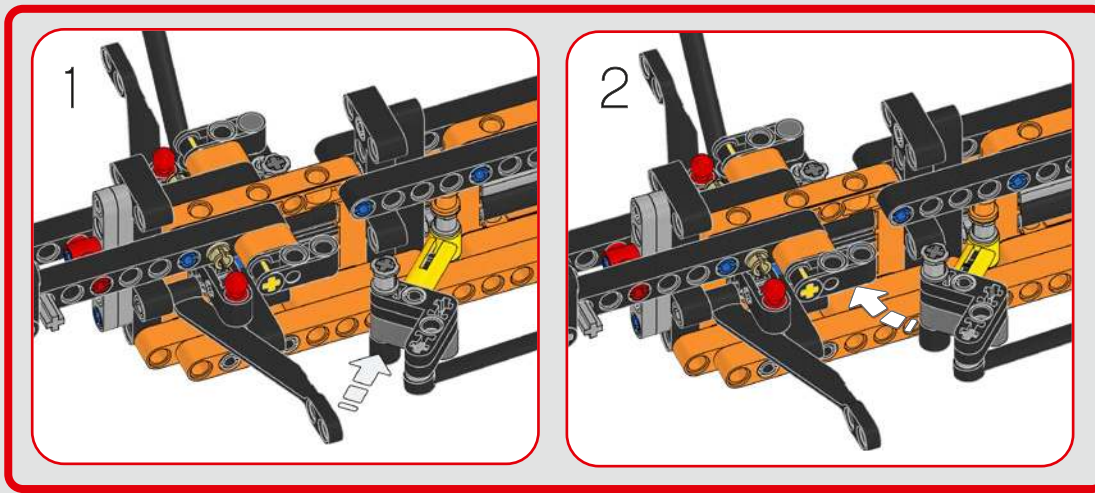

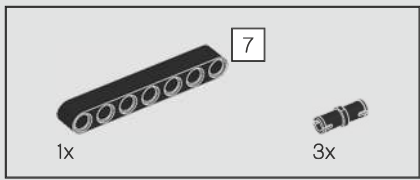

99

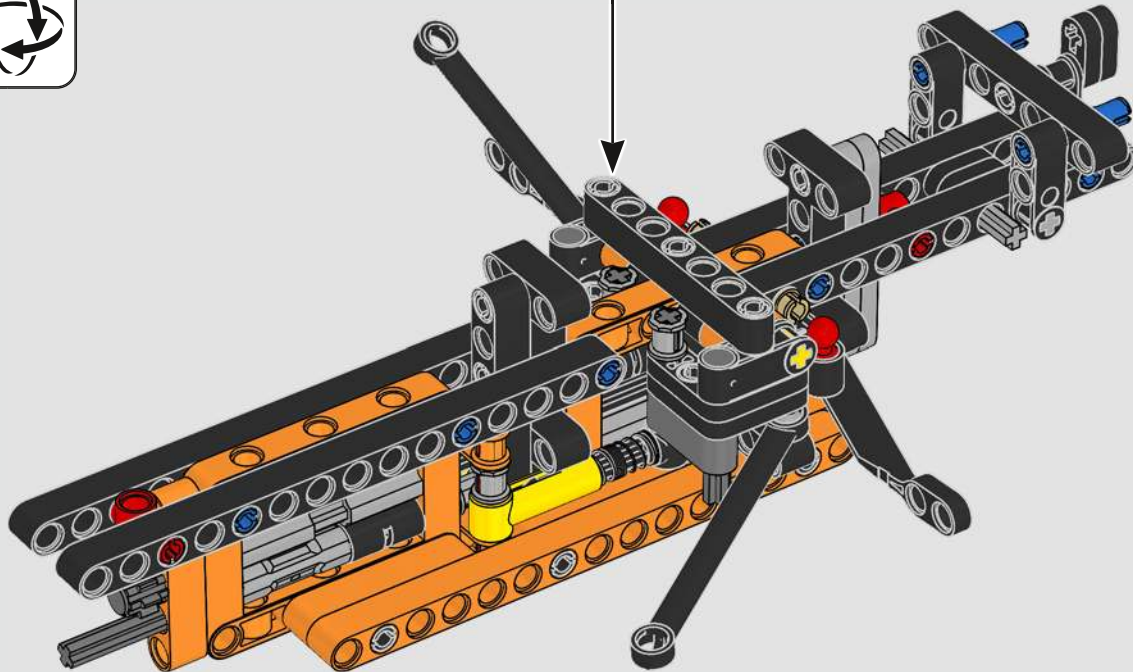
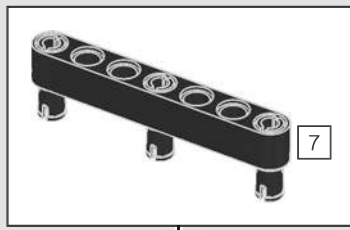

88

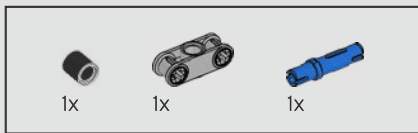

100

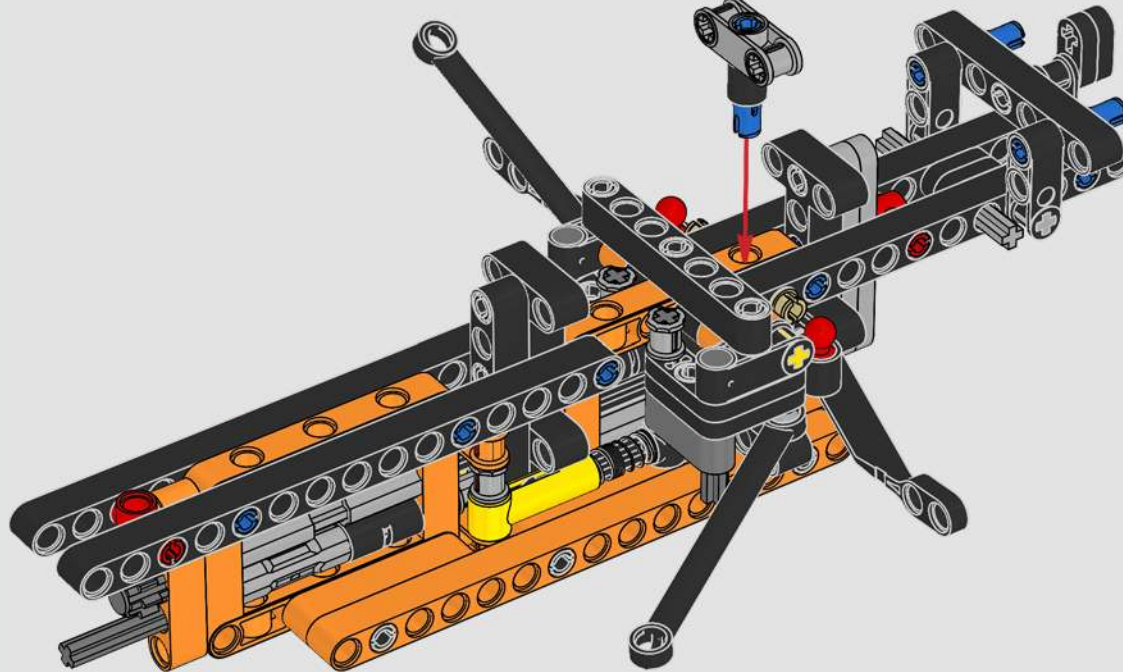
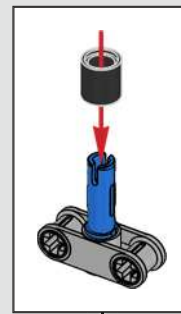

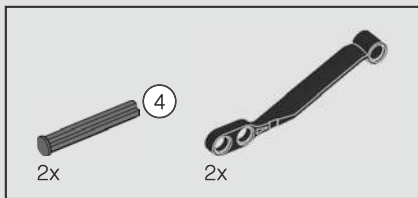

101

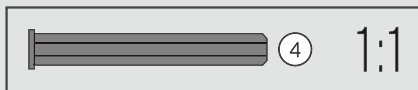
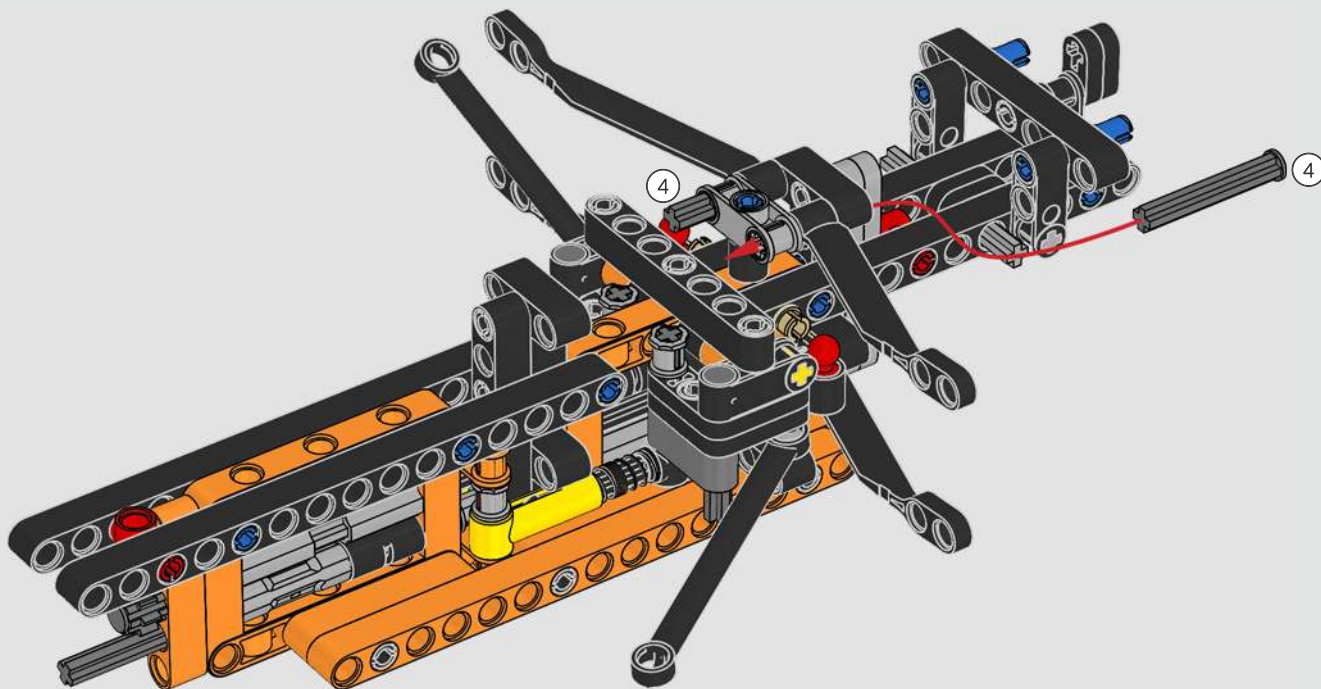

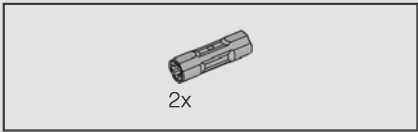

102

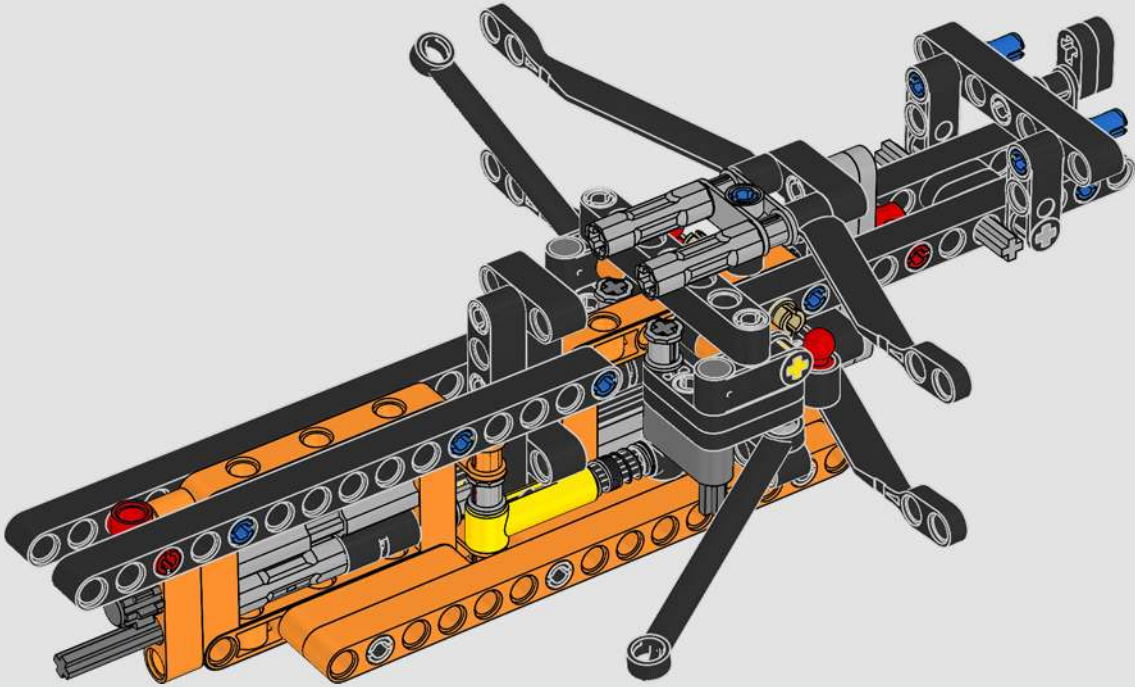

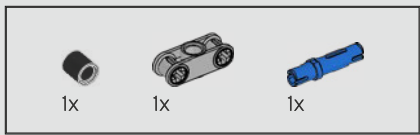

103

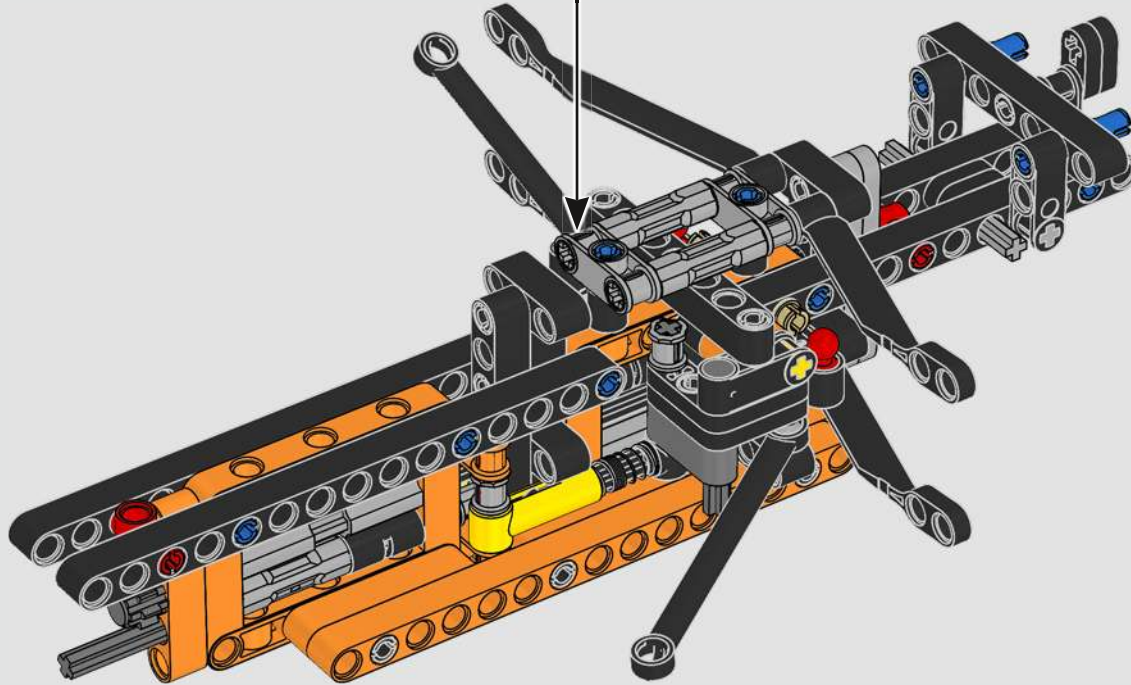
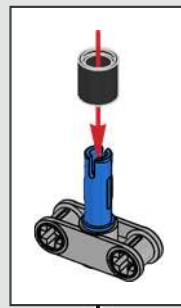

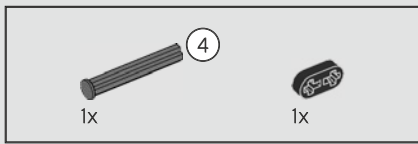

104

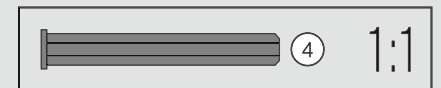
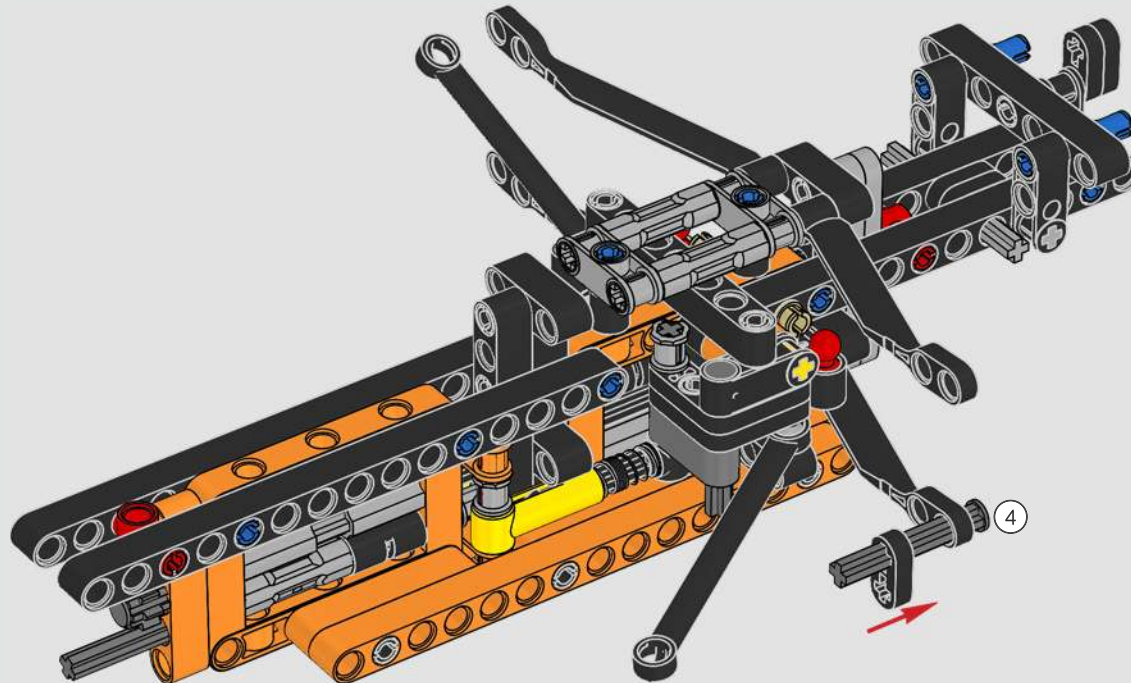

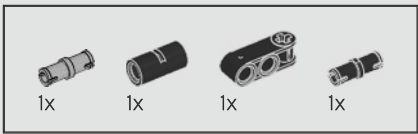

105

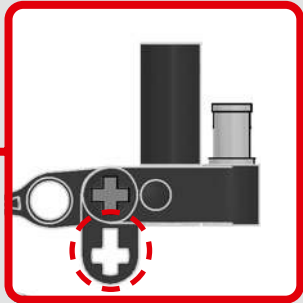
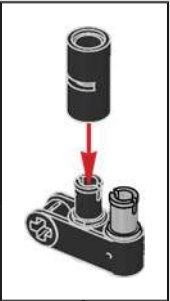
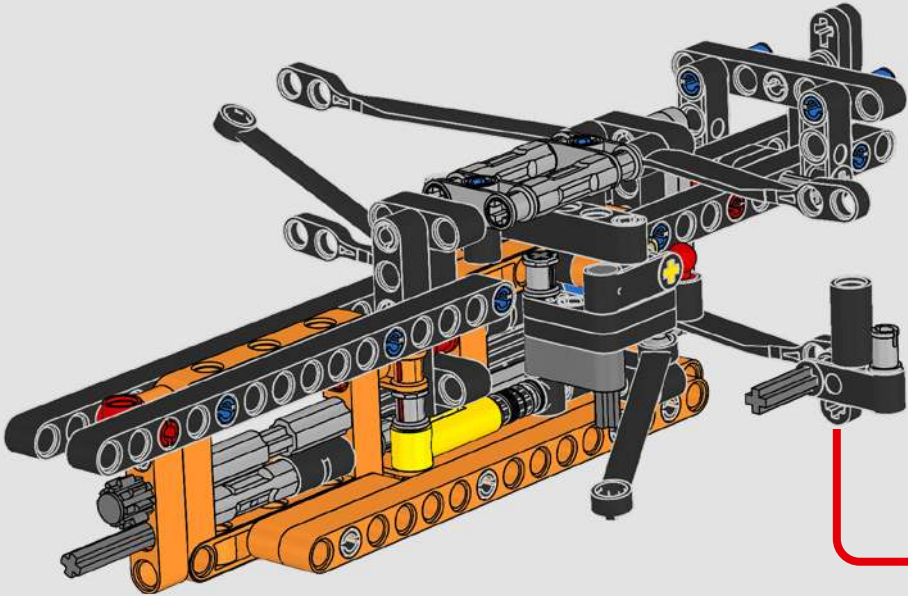

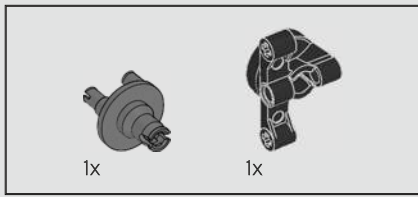

106

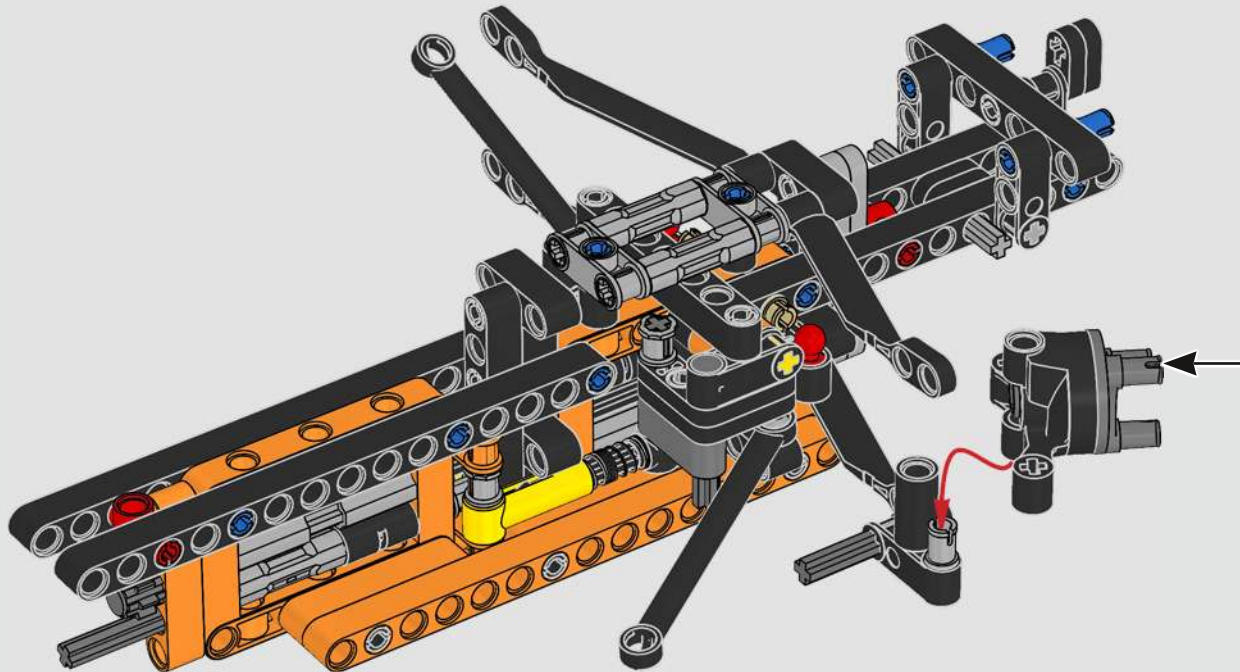
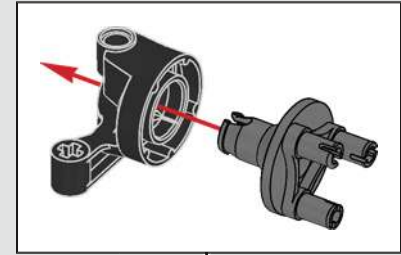

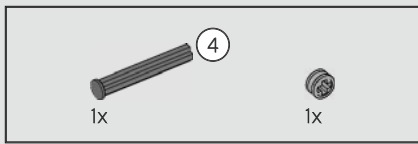

107

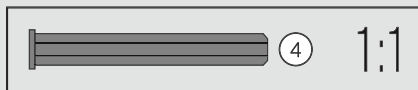
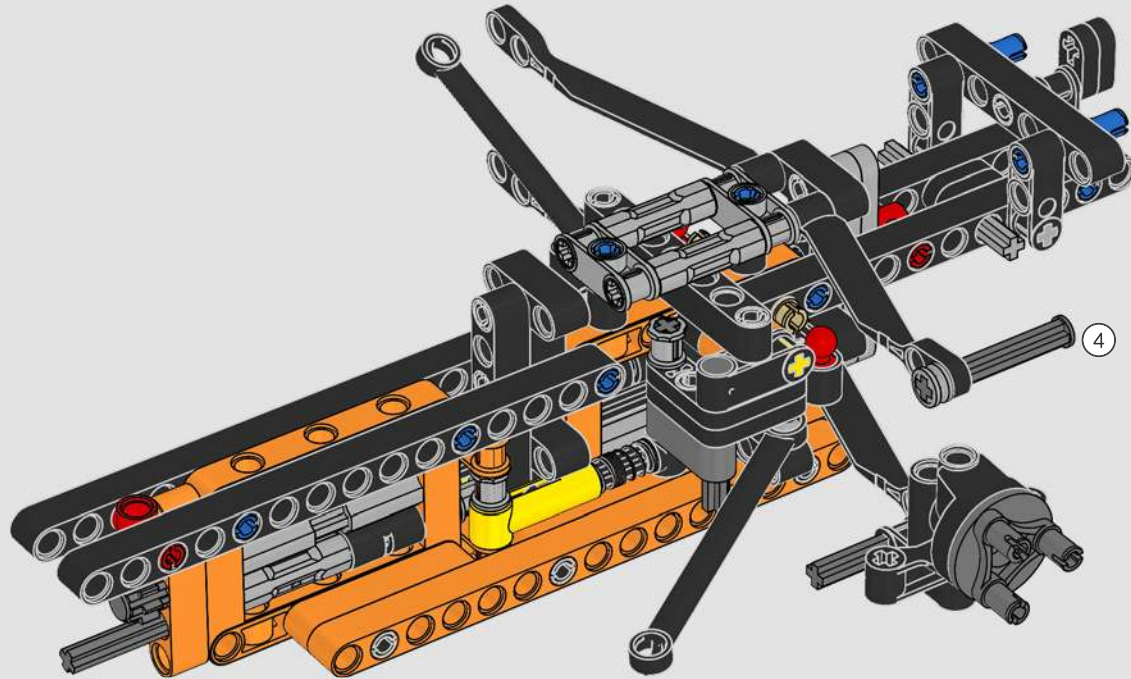

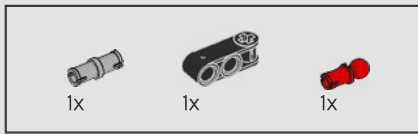

108

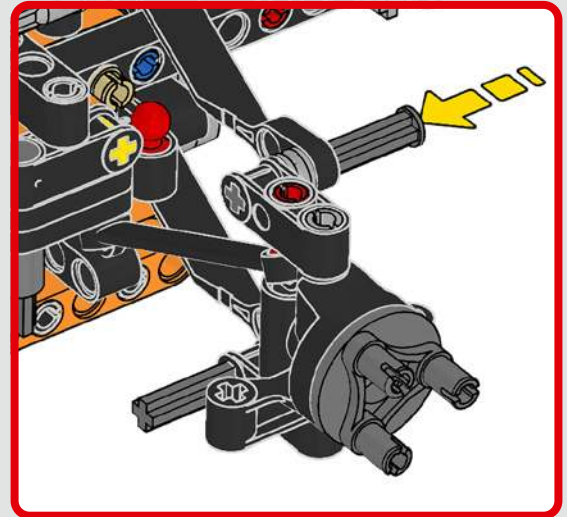
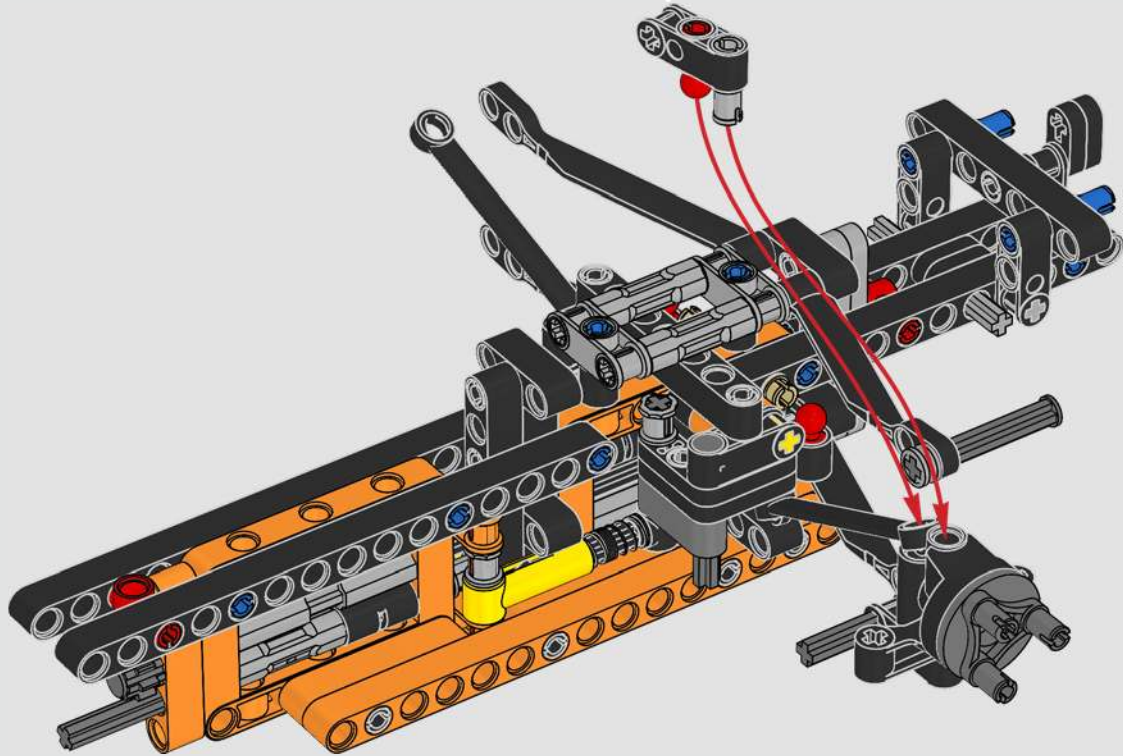
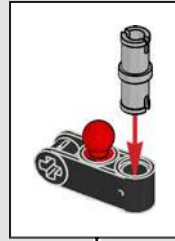



109

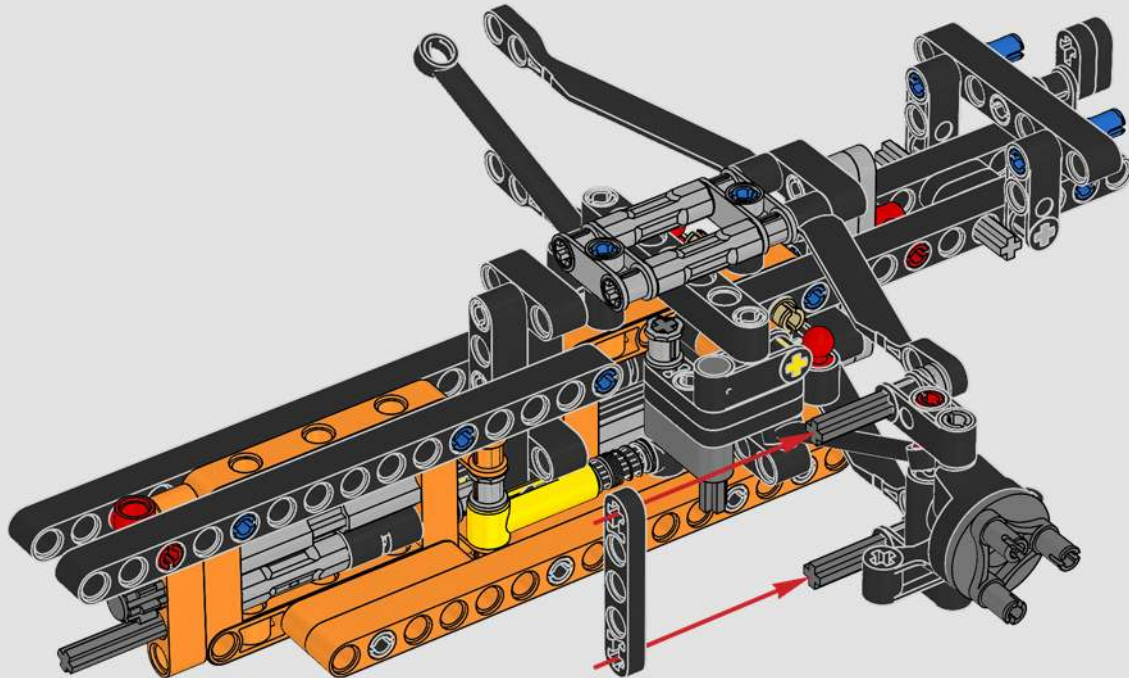

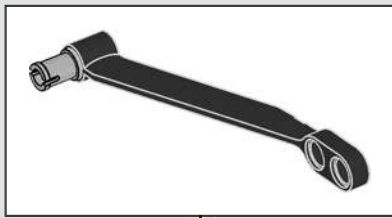
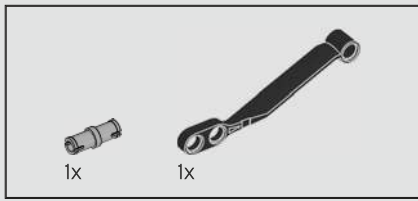

110

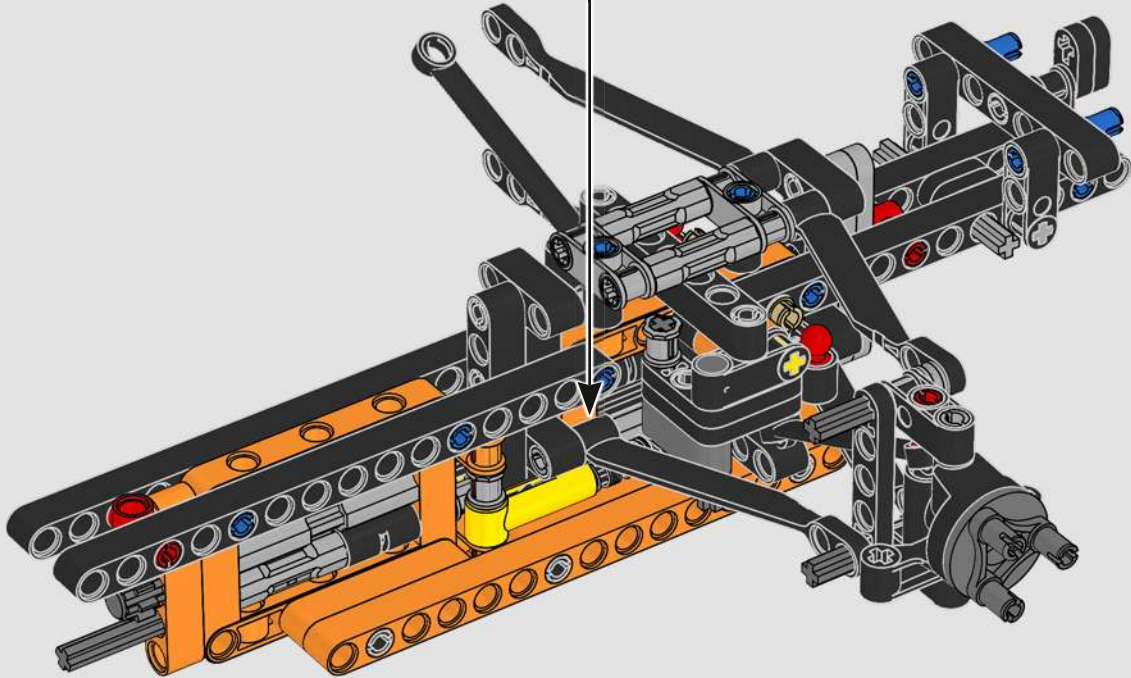

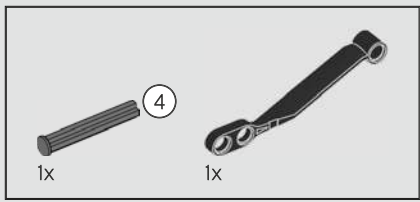

111

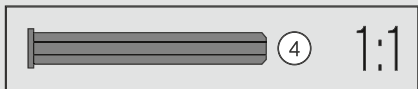
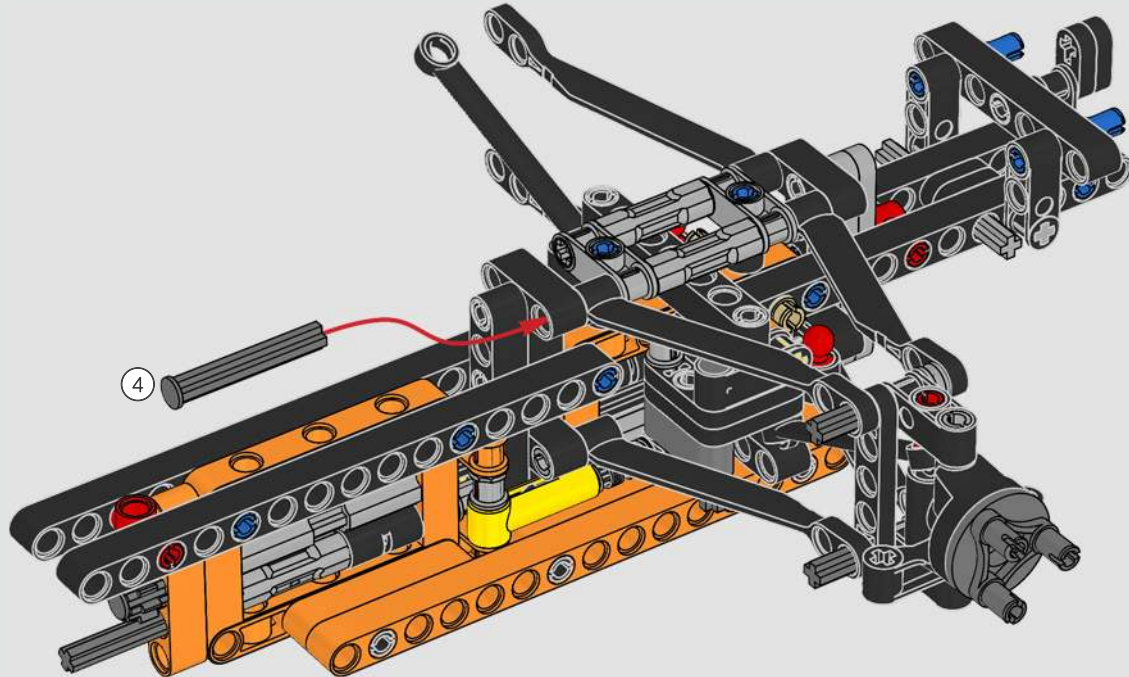



112

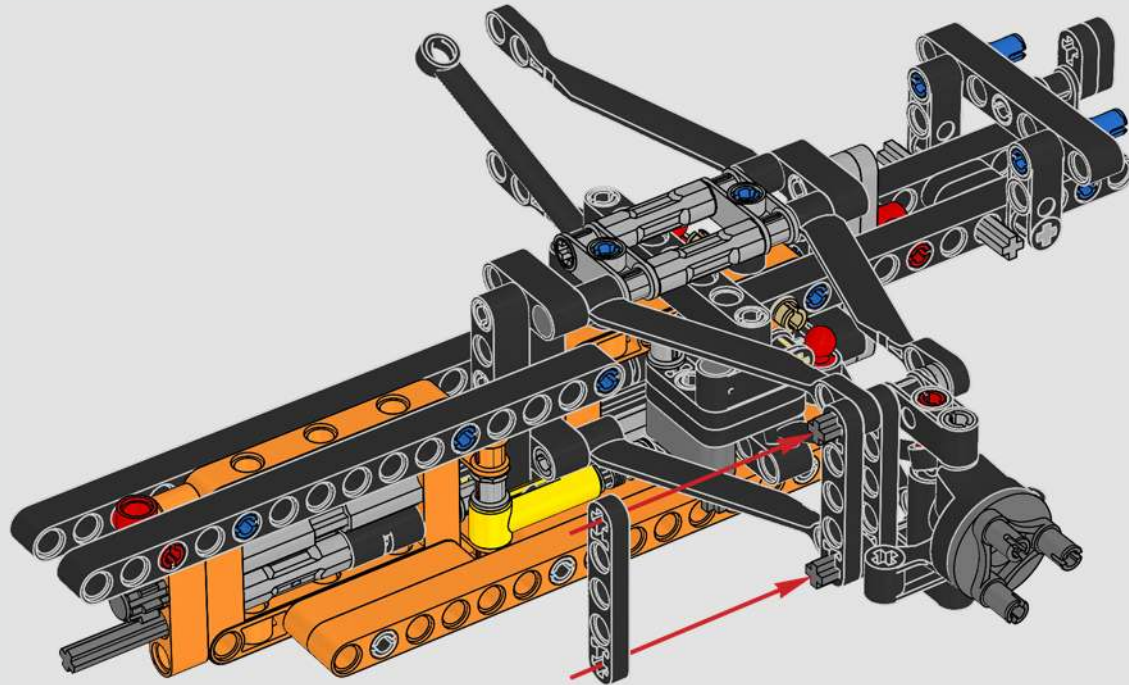

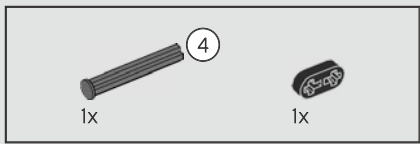

113

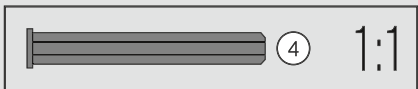
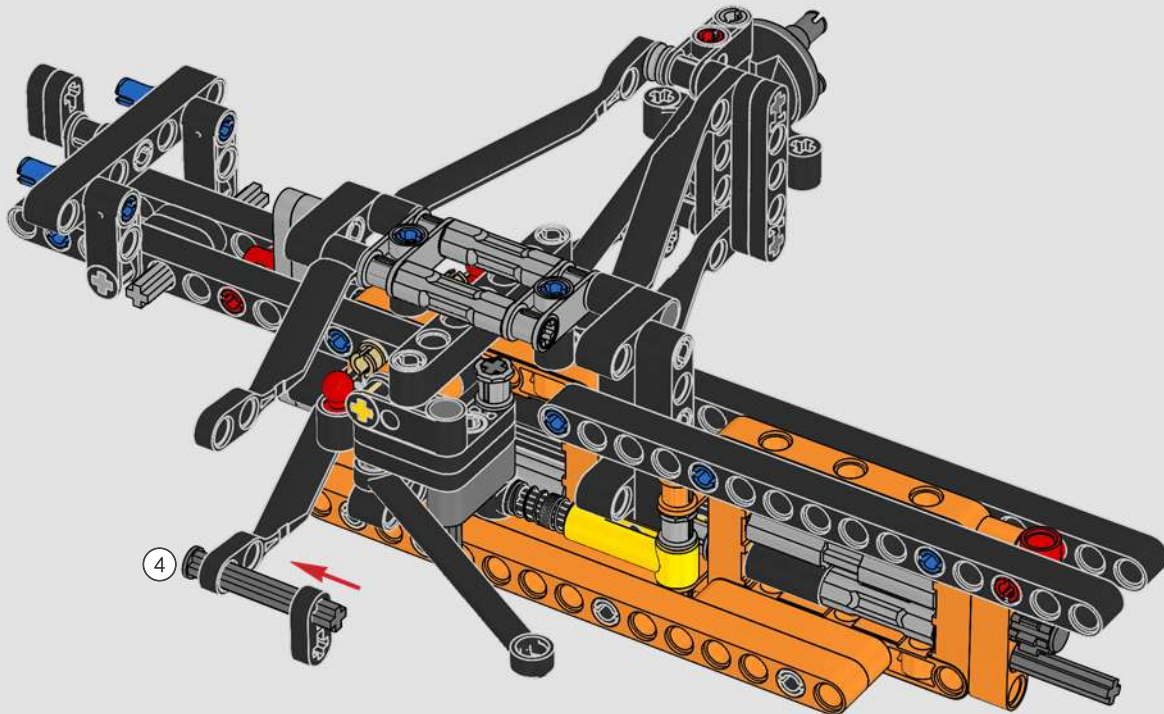

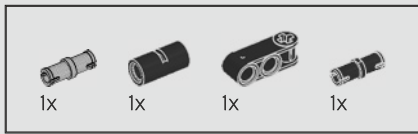

114

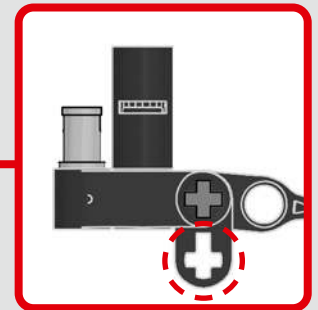
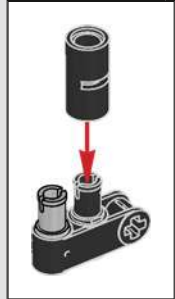
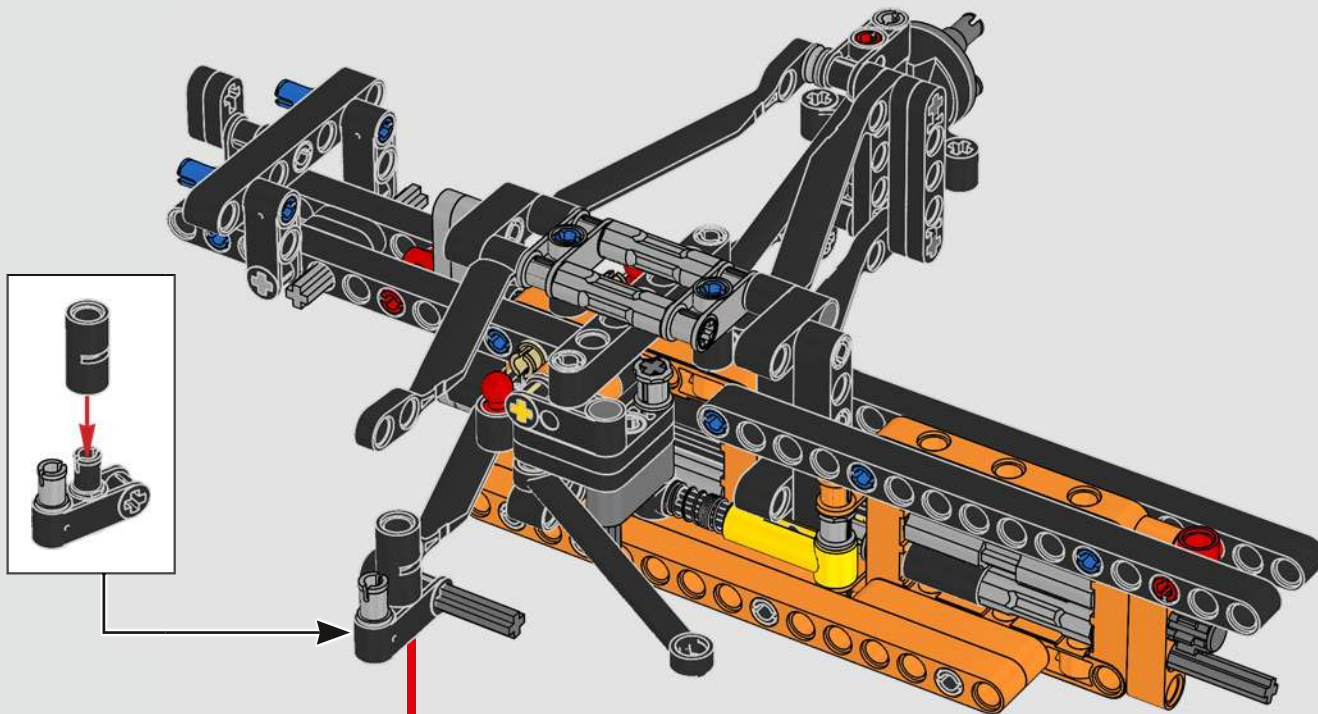

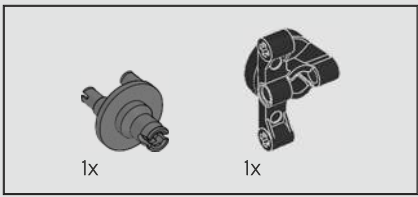

115

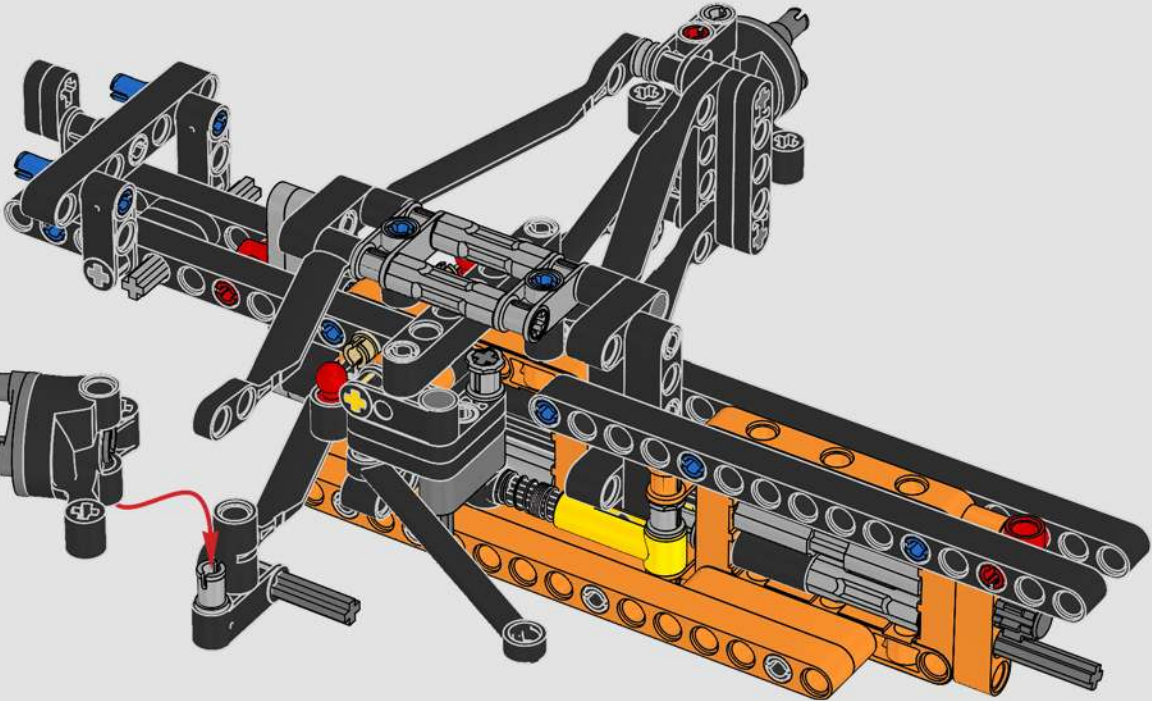
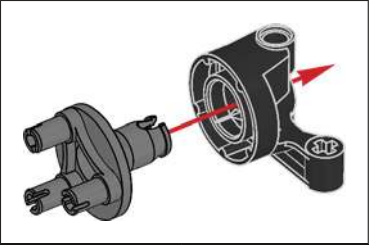

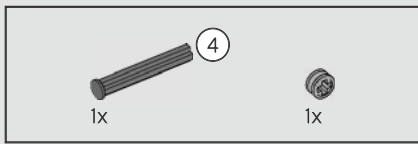

116

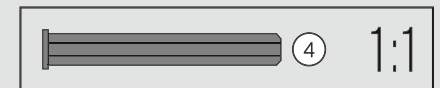
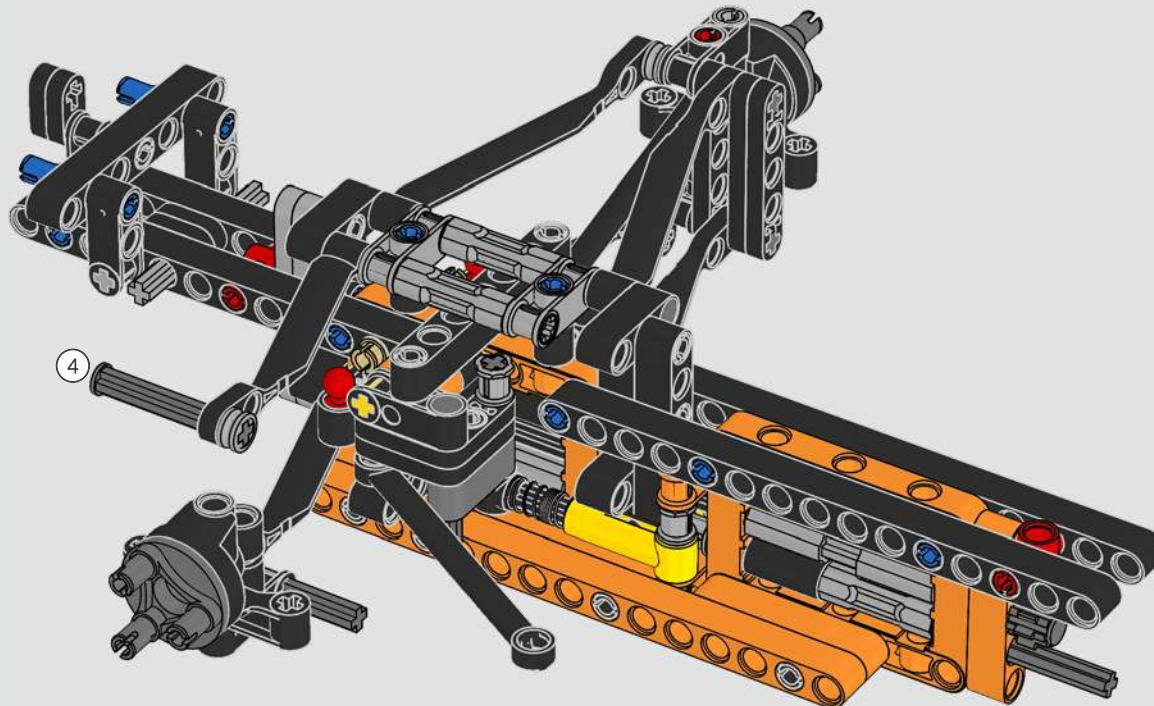

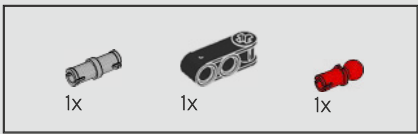

117

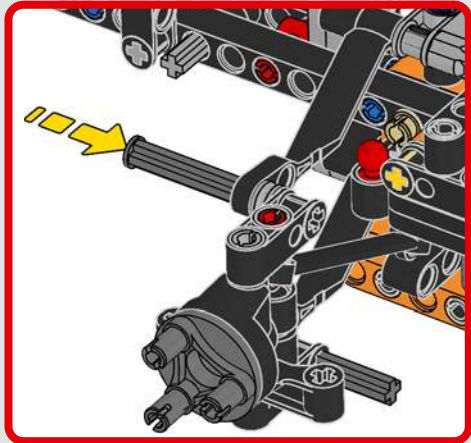
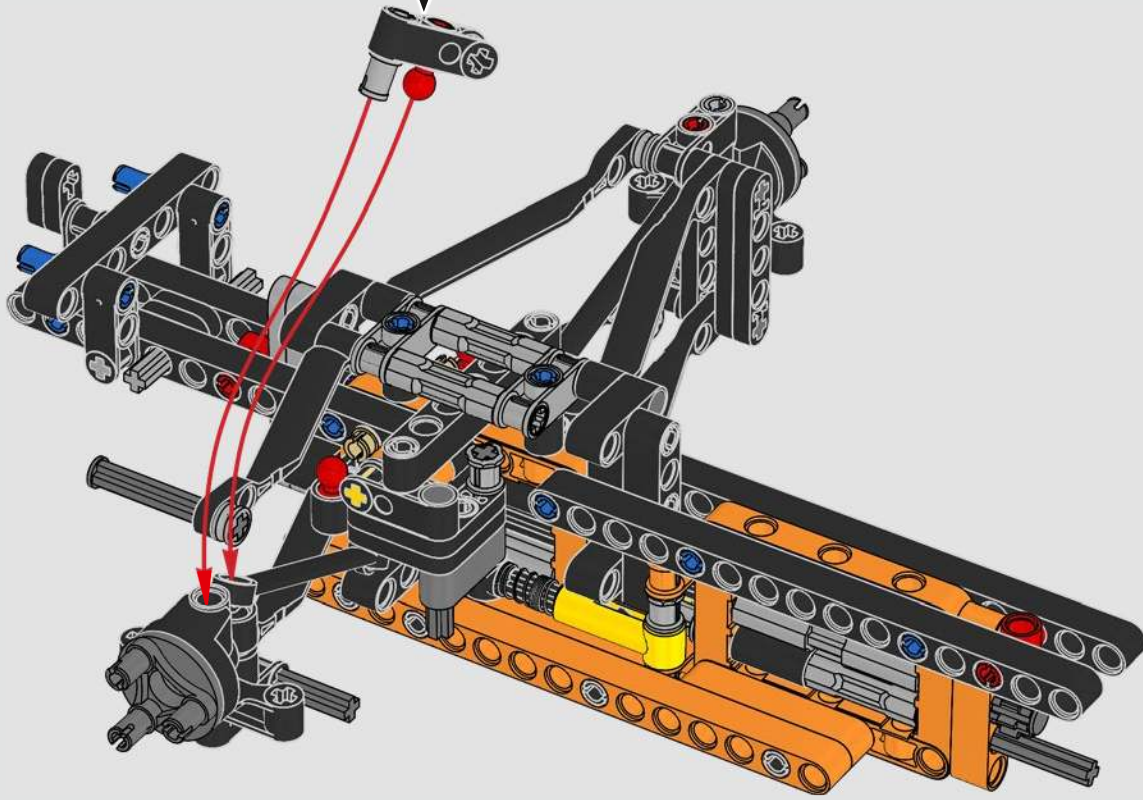
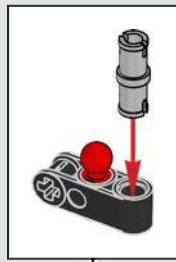



118

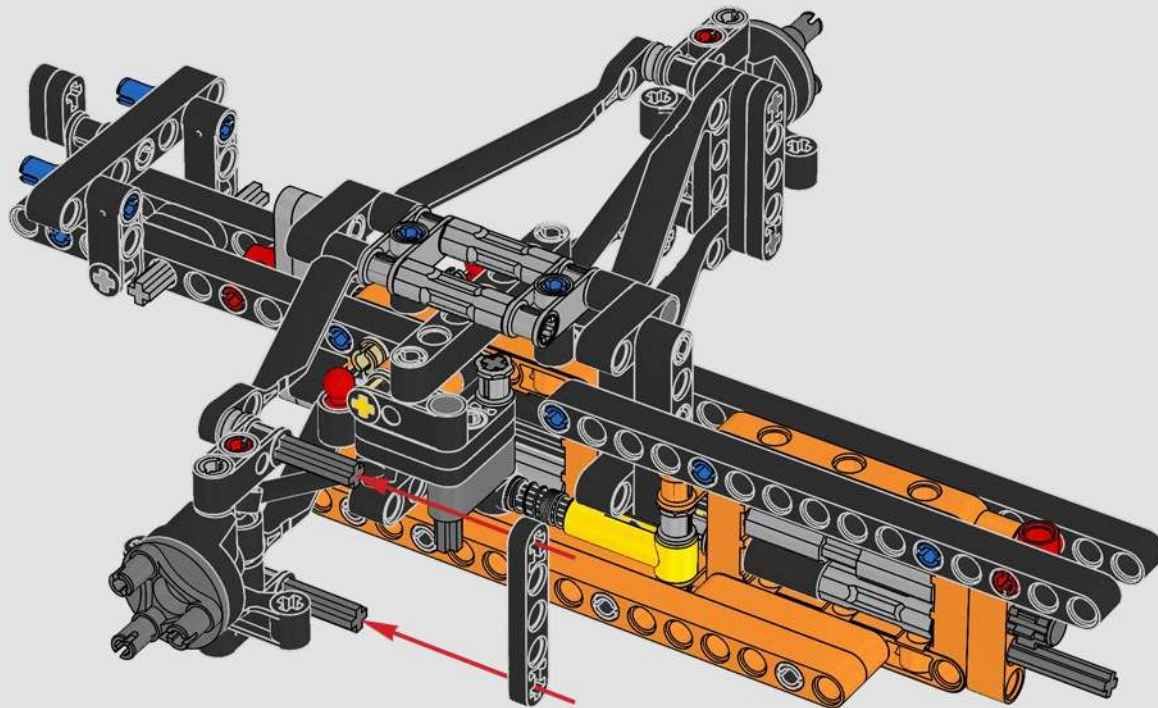

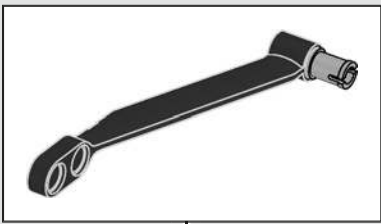
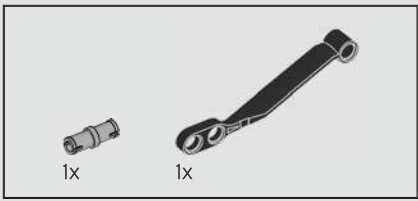

119

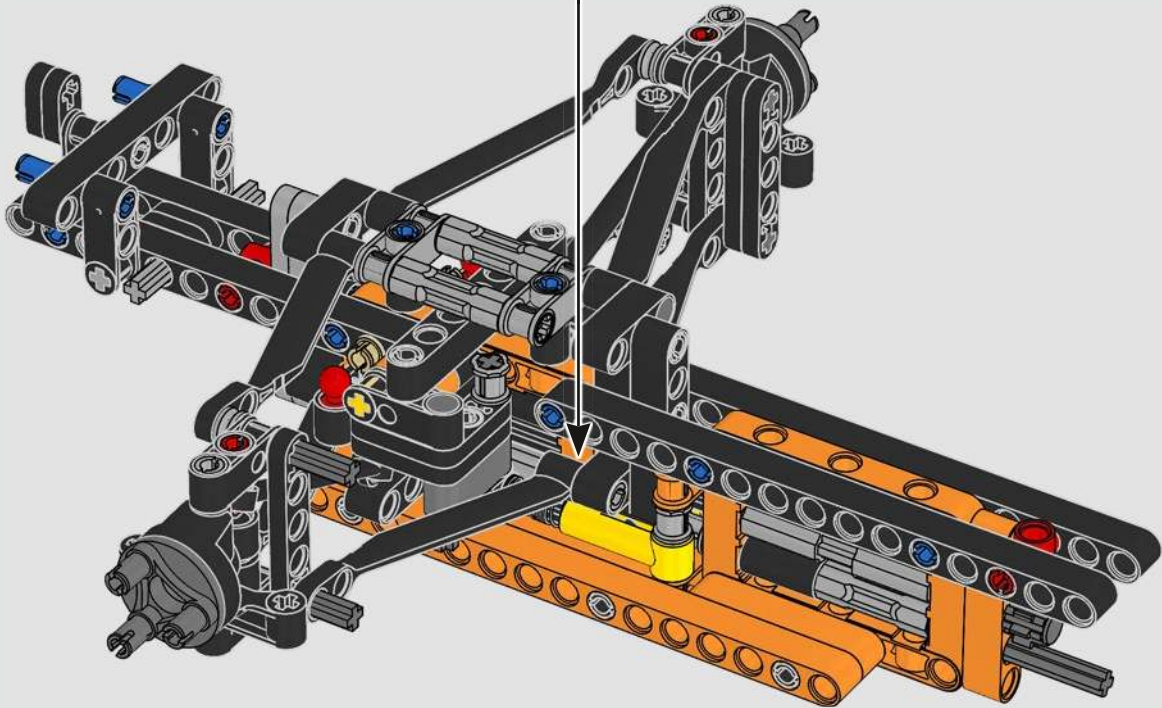

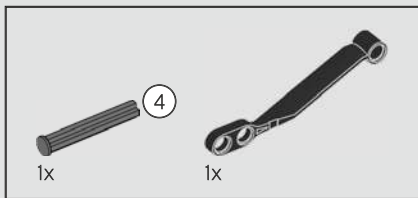

120

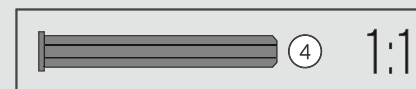
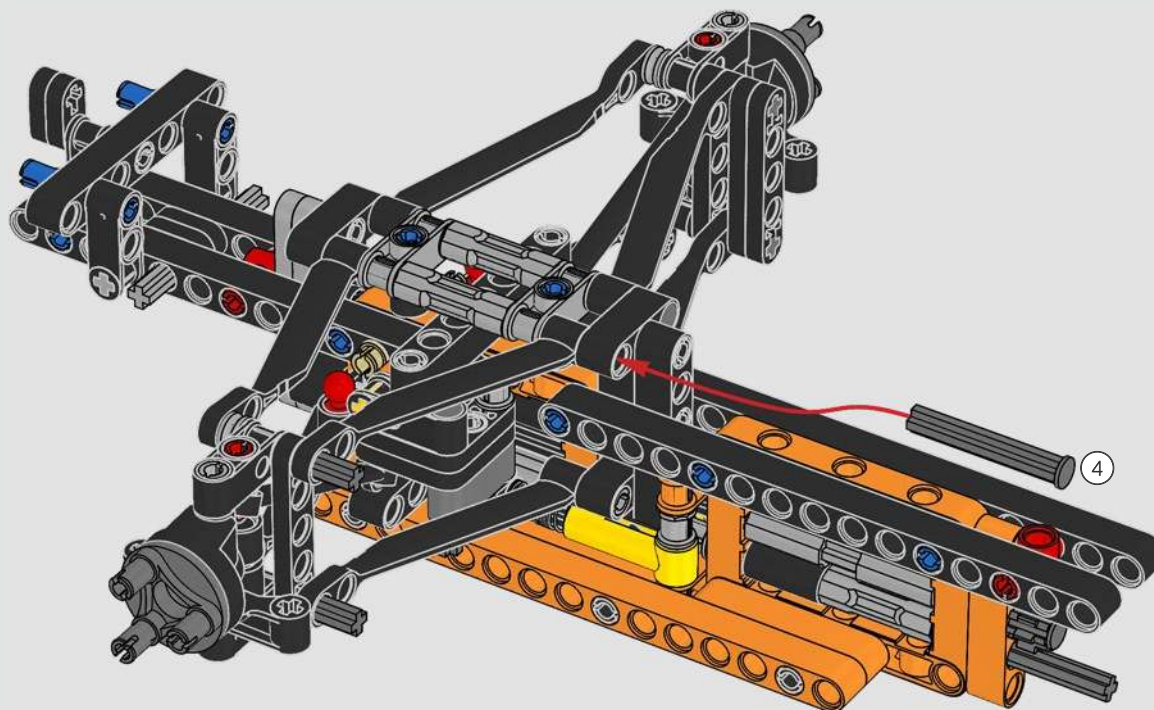



121

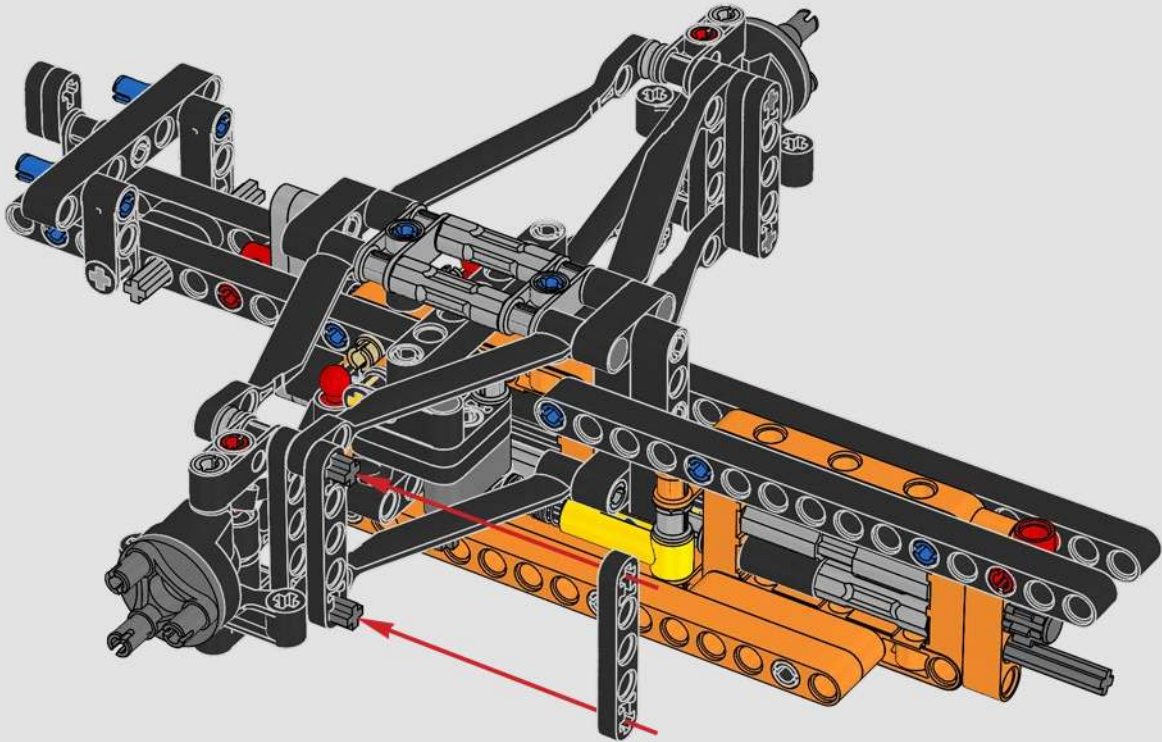

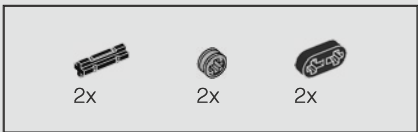

122

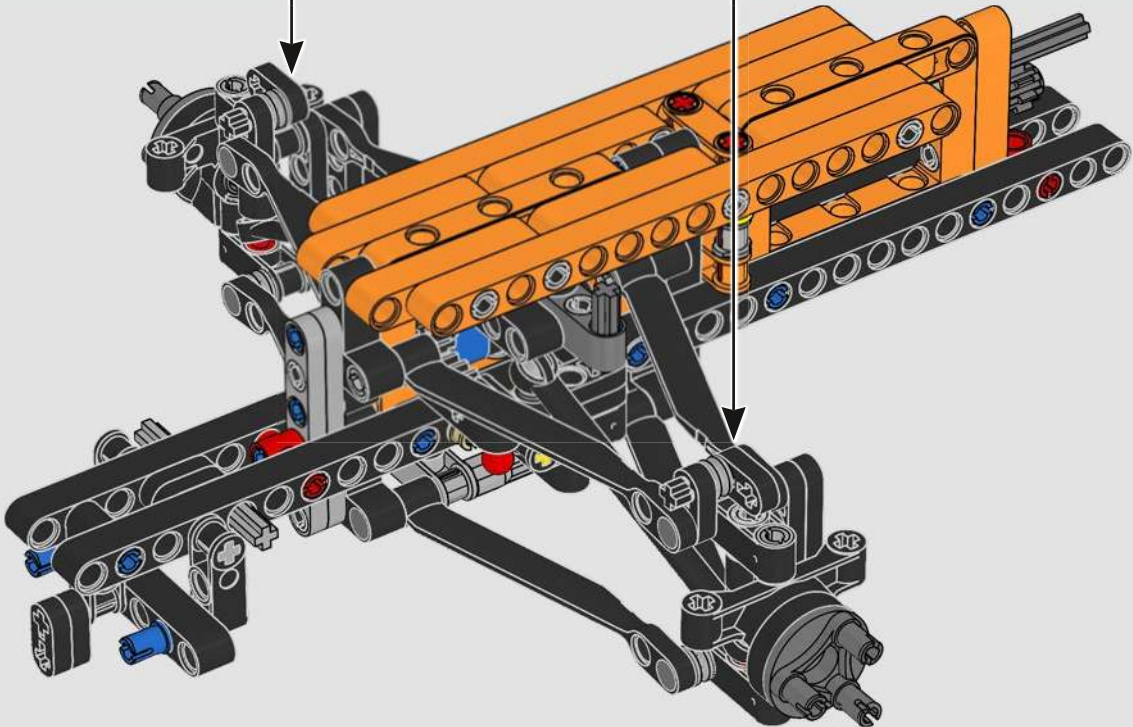
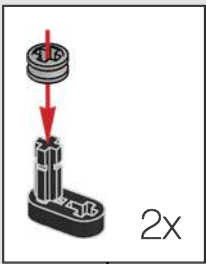



123

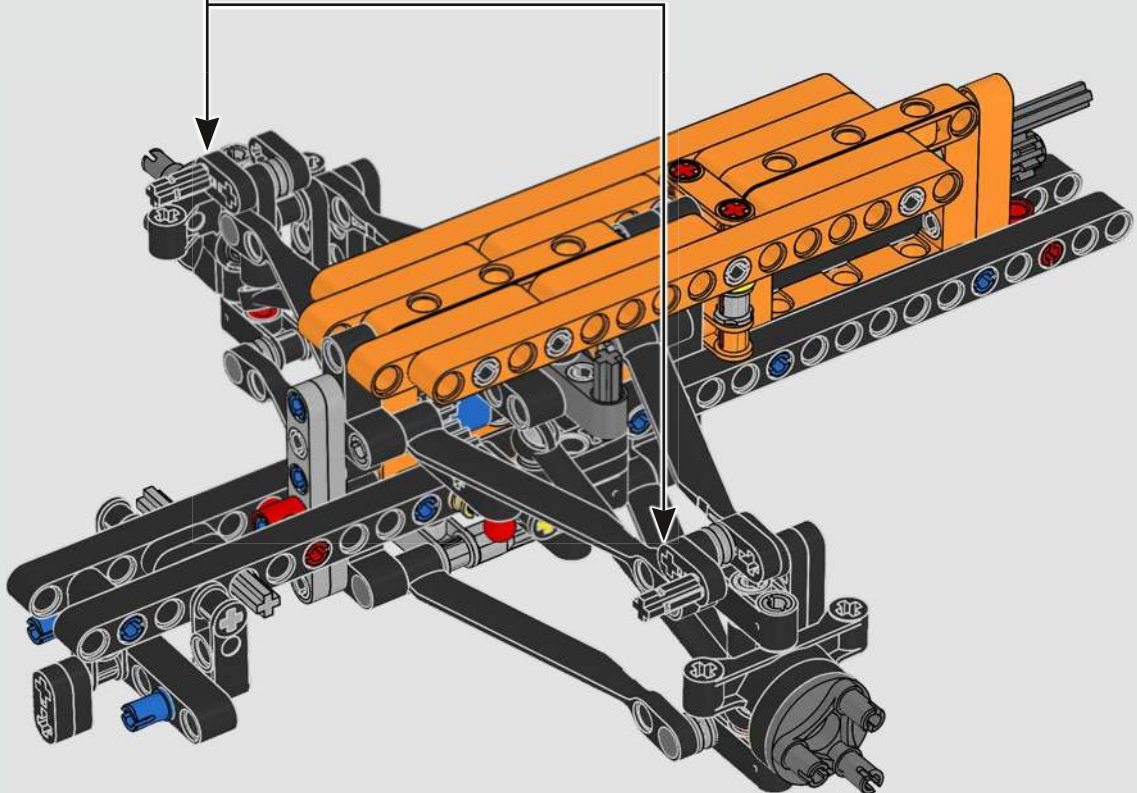

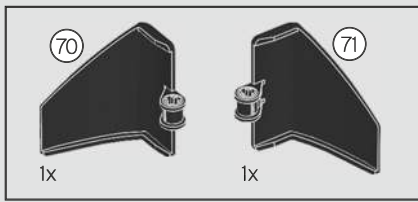

124

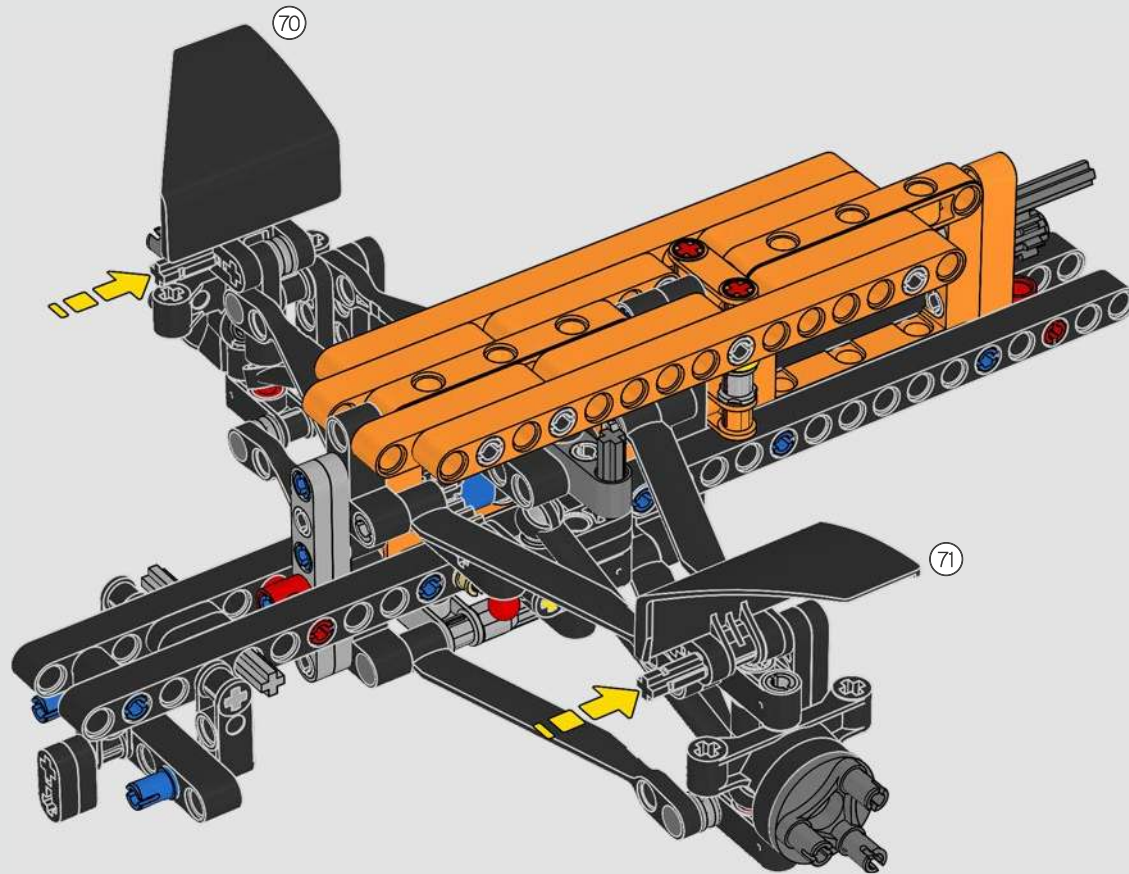

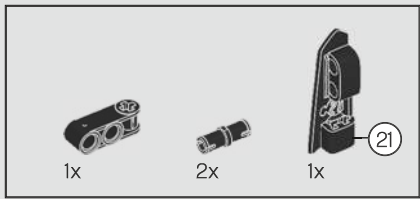

125

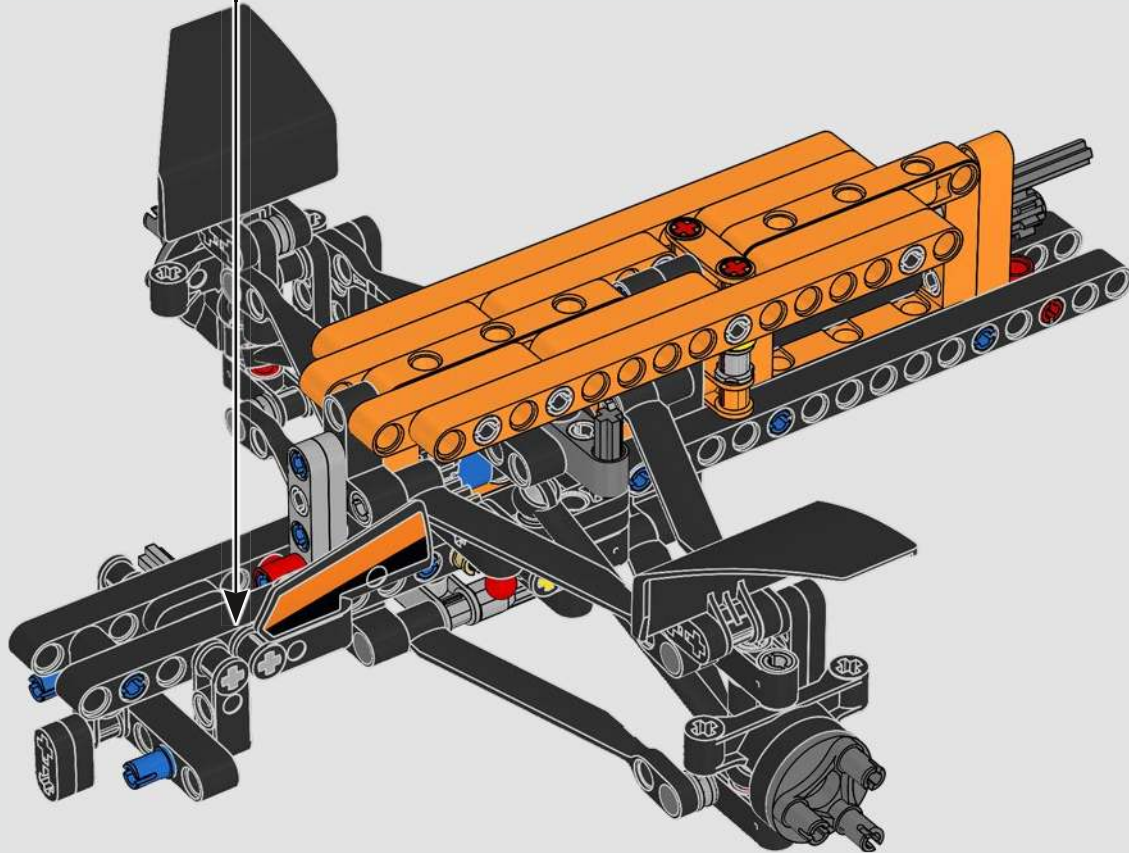
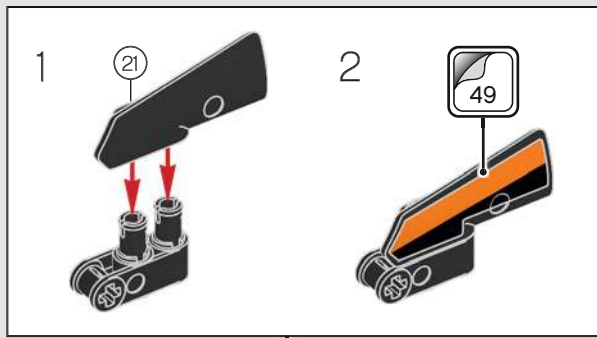

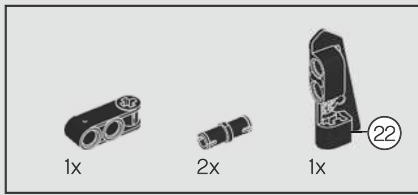

126

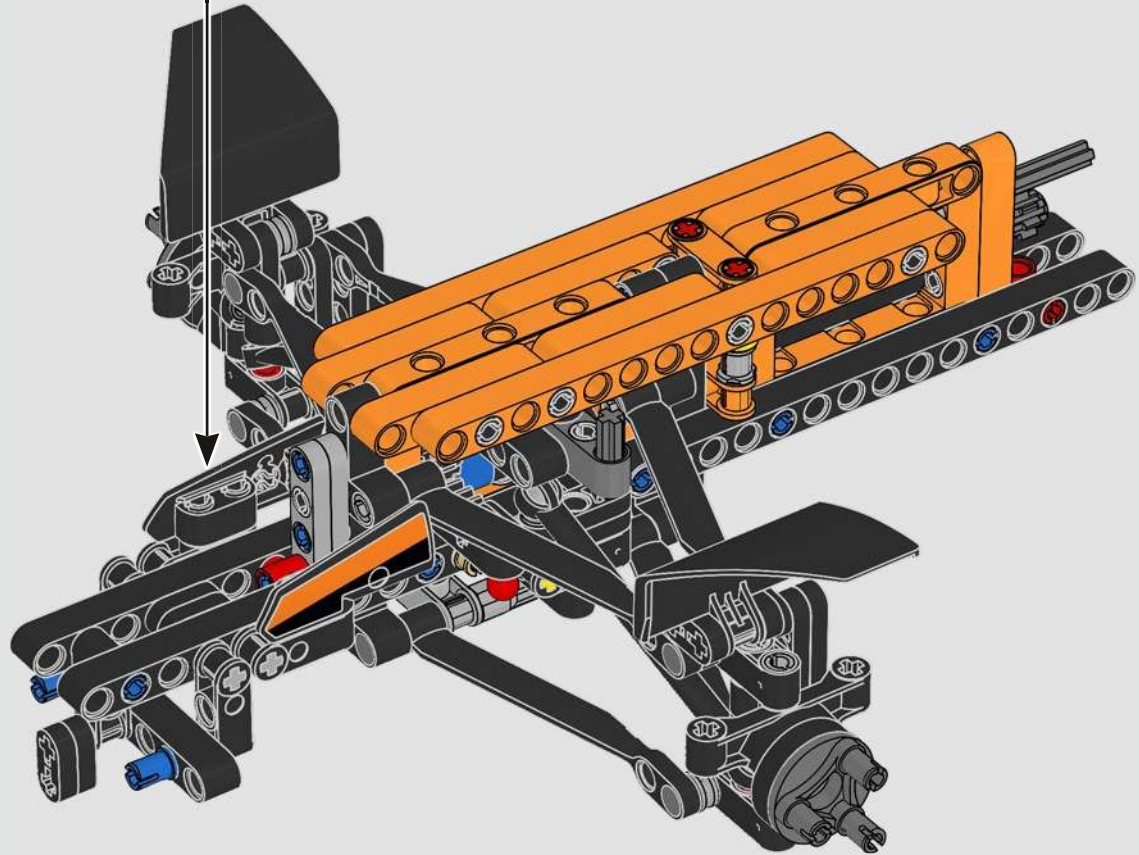
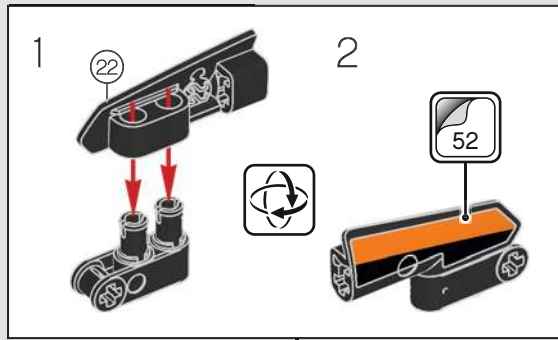



2x

127

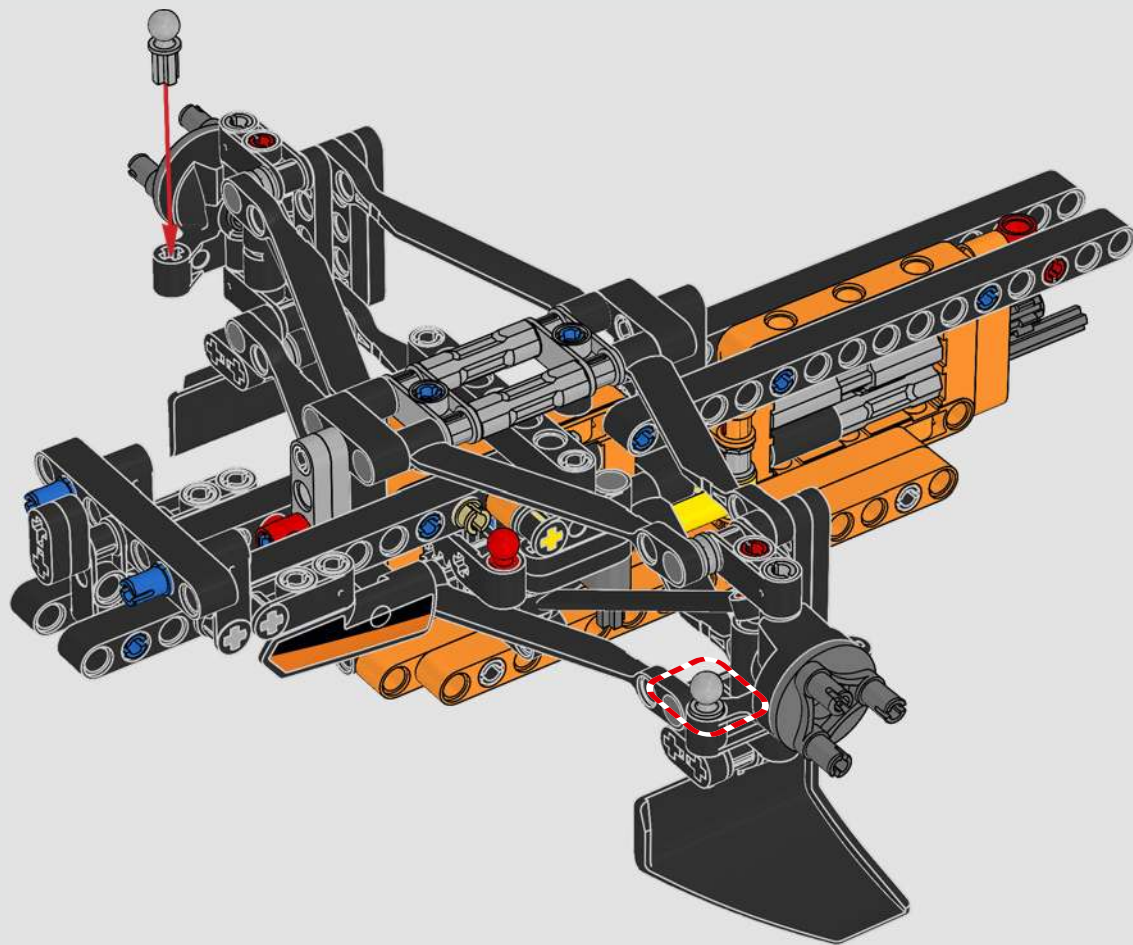

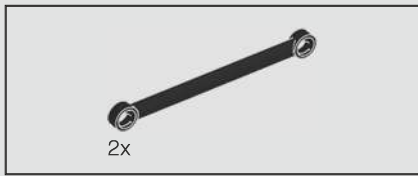

128

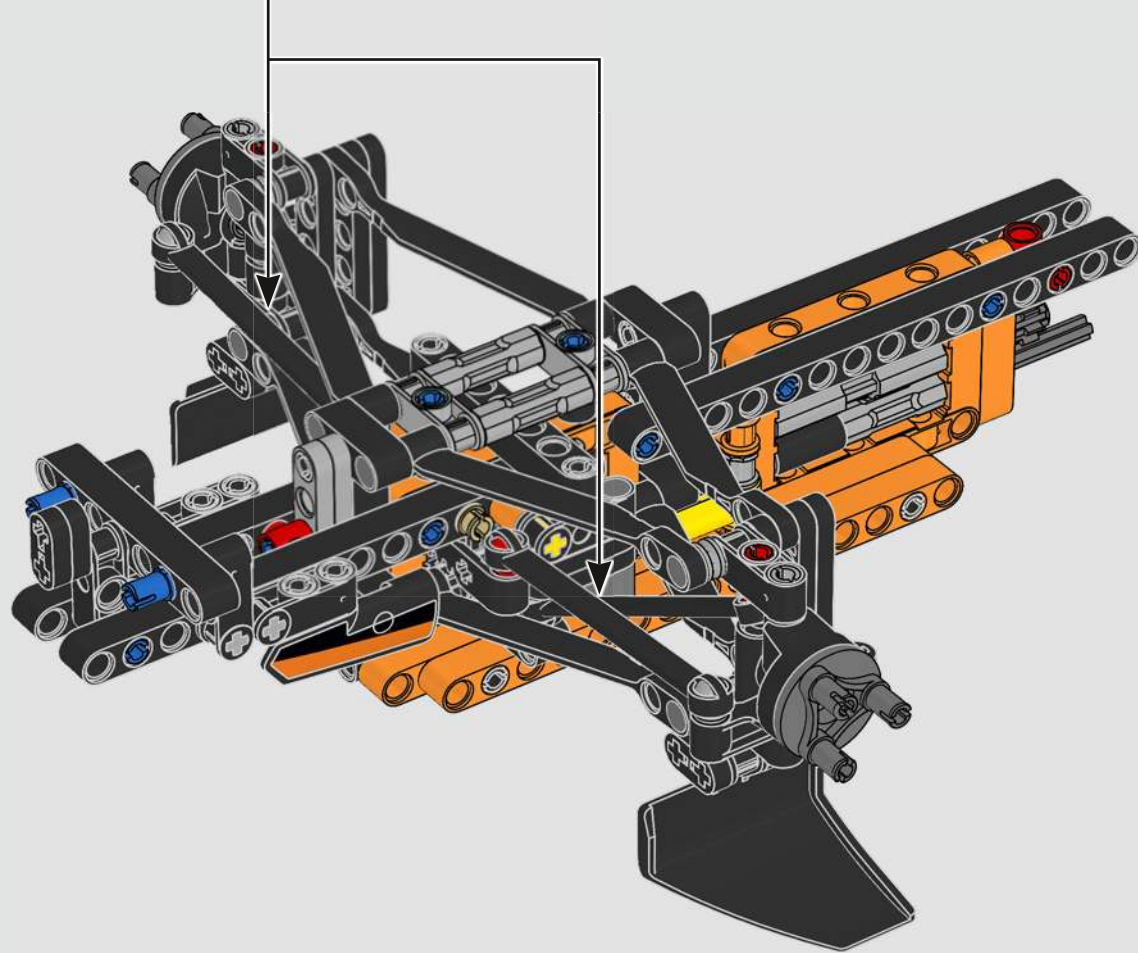
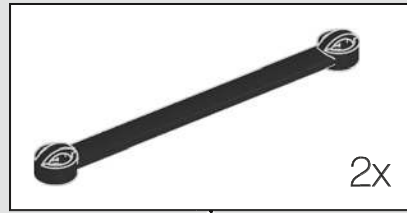



129

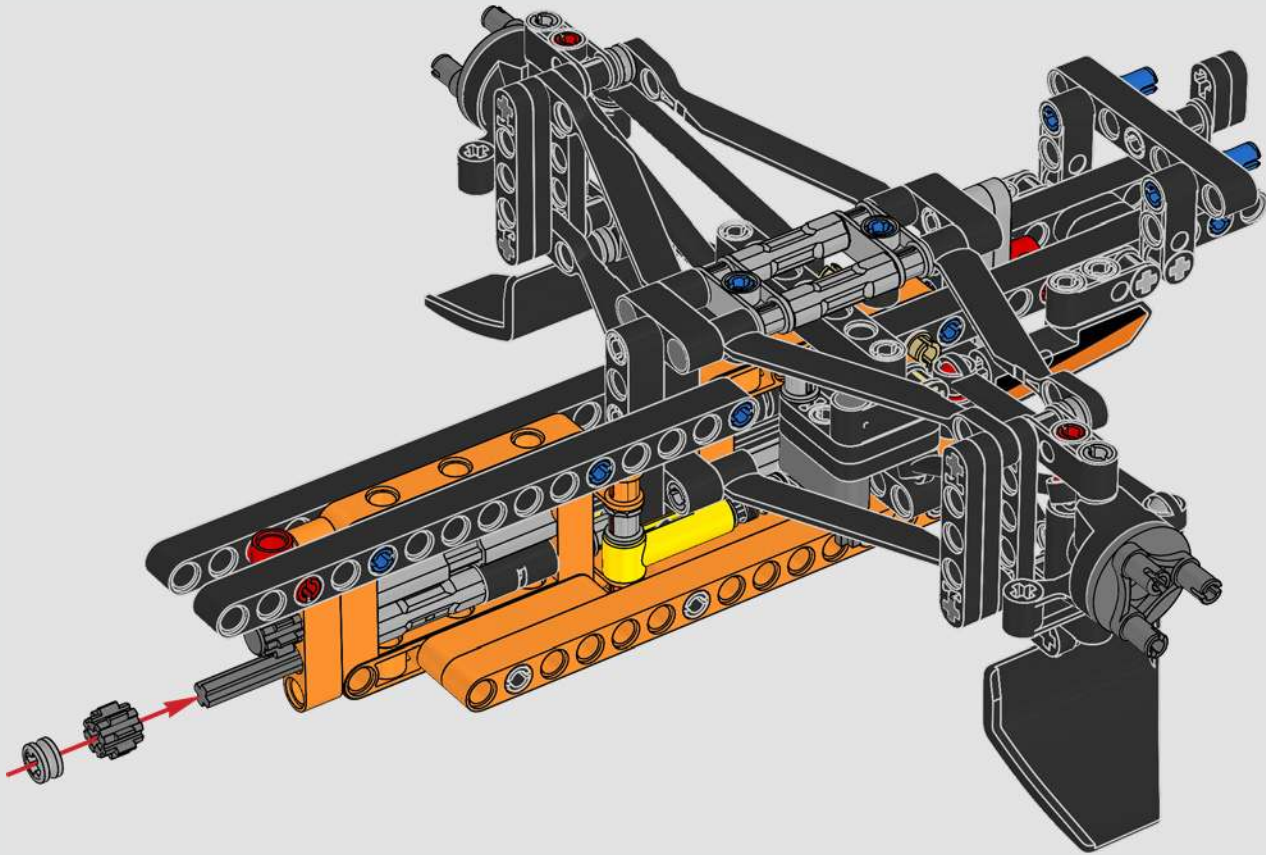

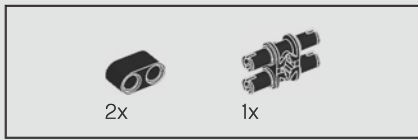

130

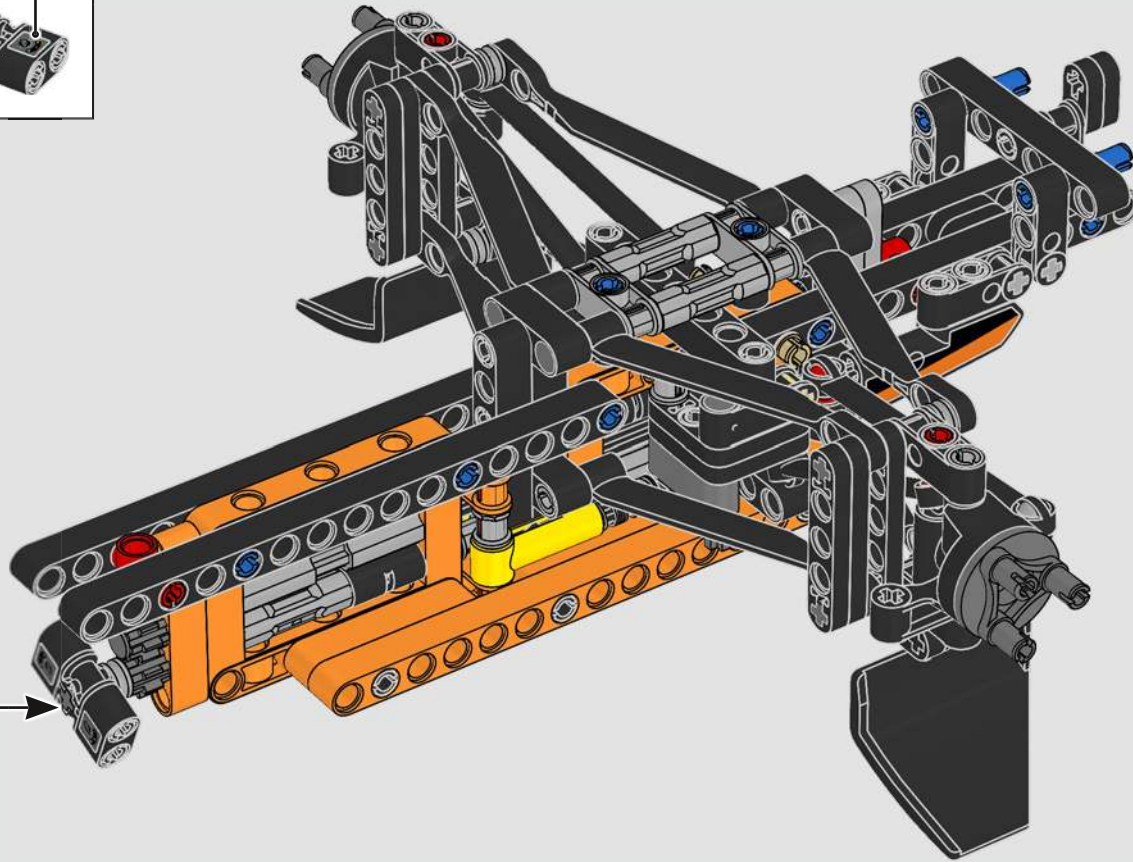
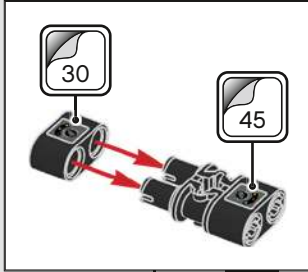



4x

131

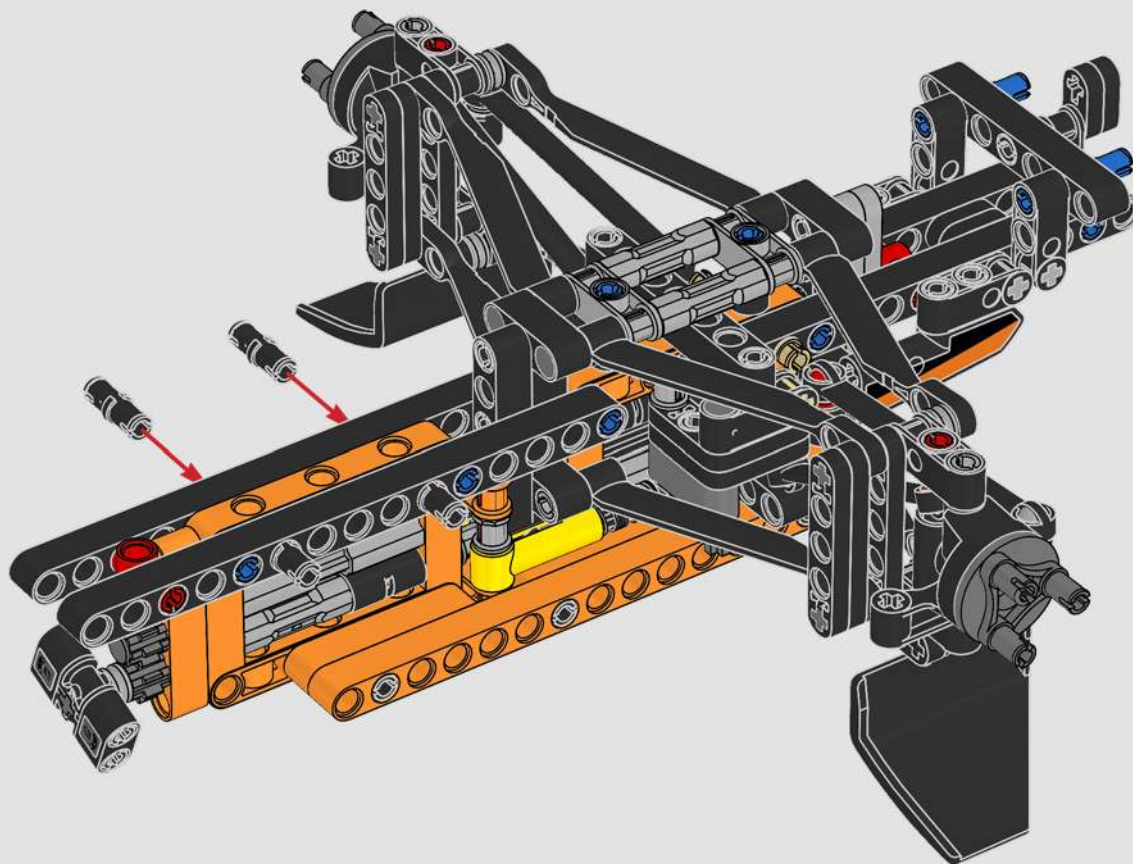

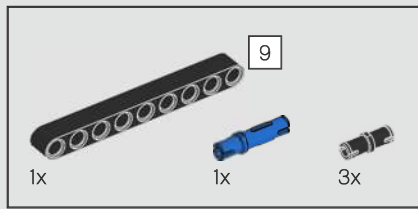

132

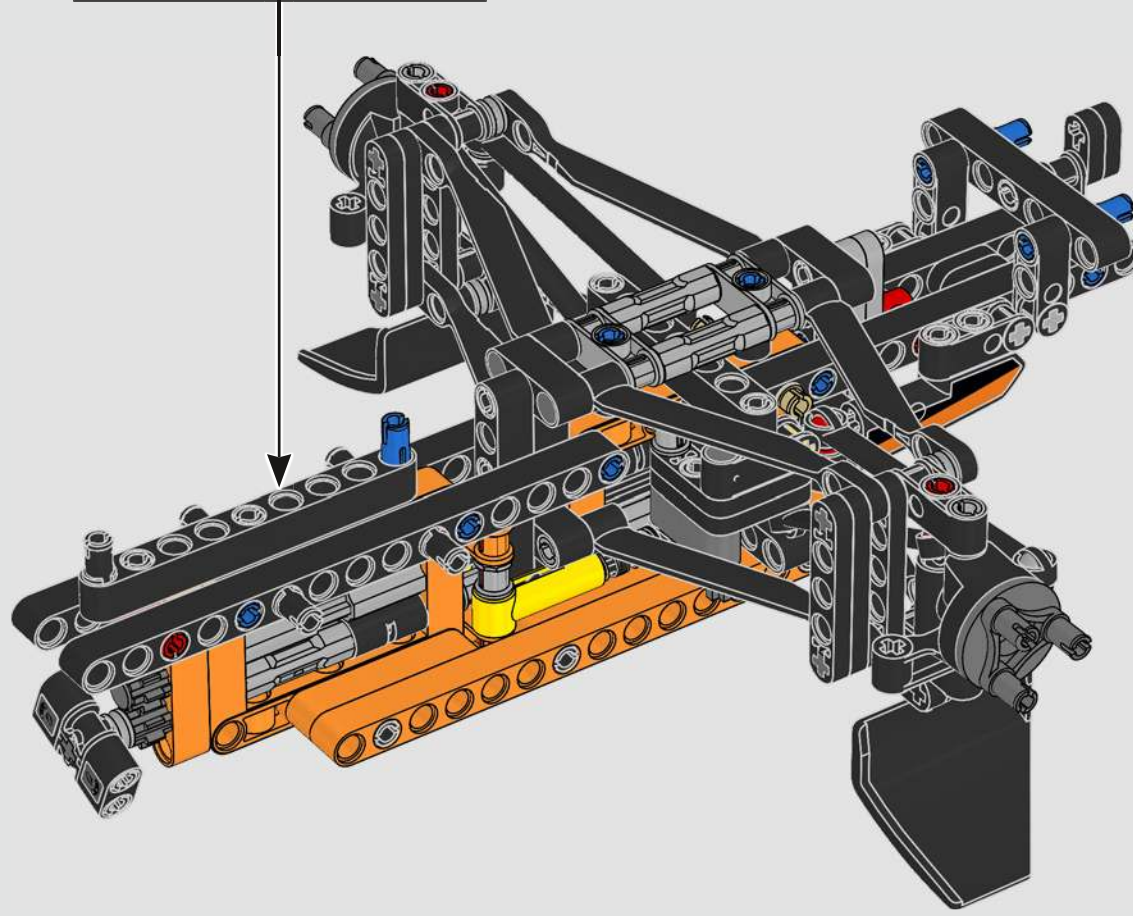
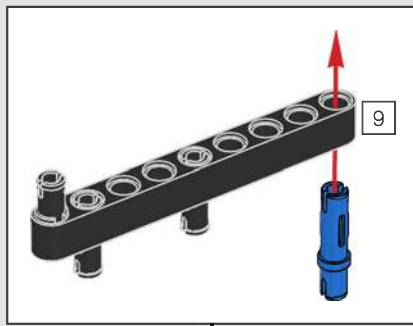

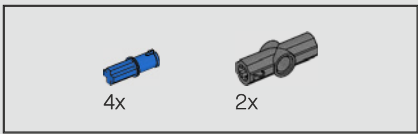

133

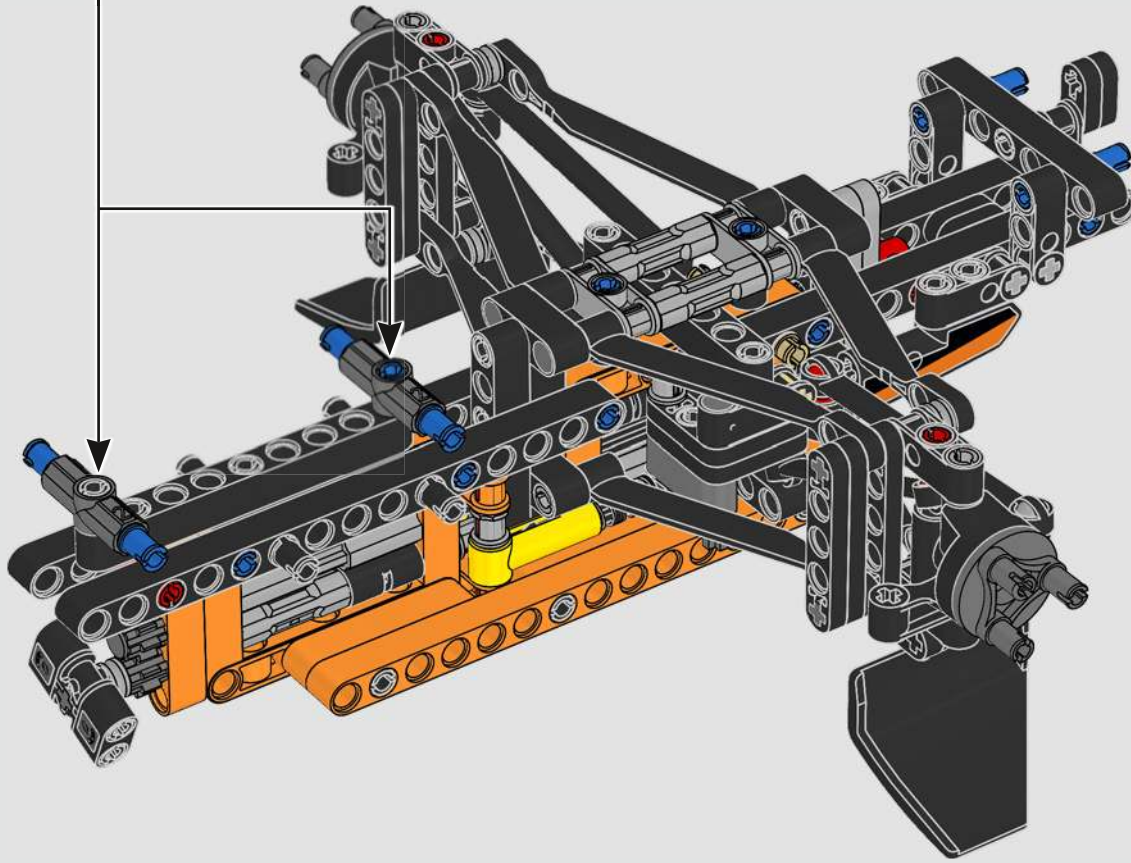
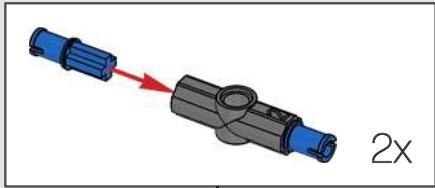

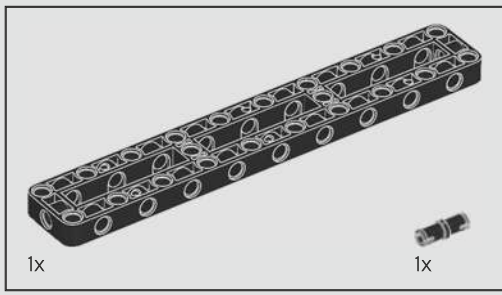

134

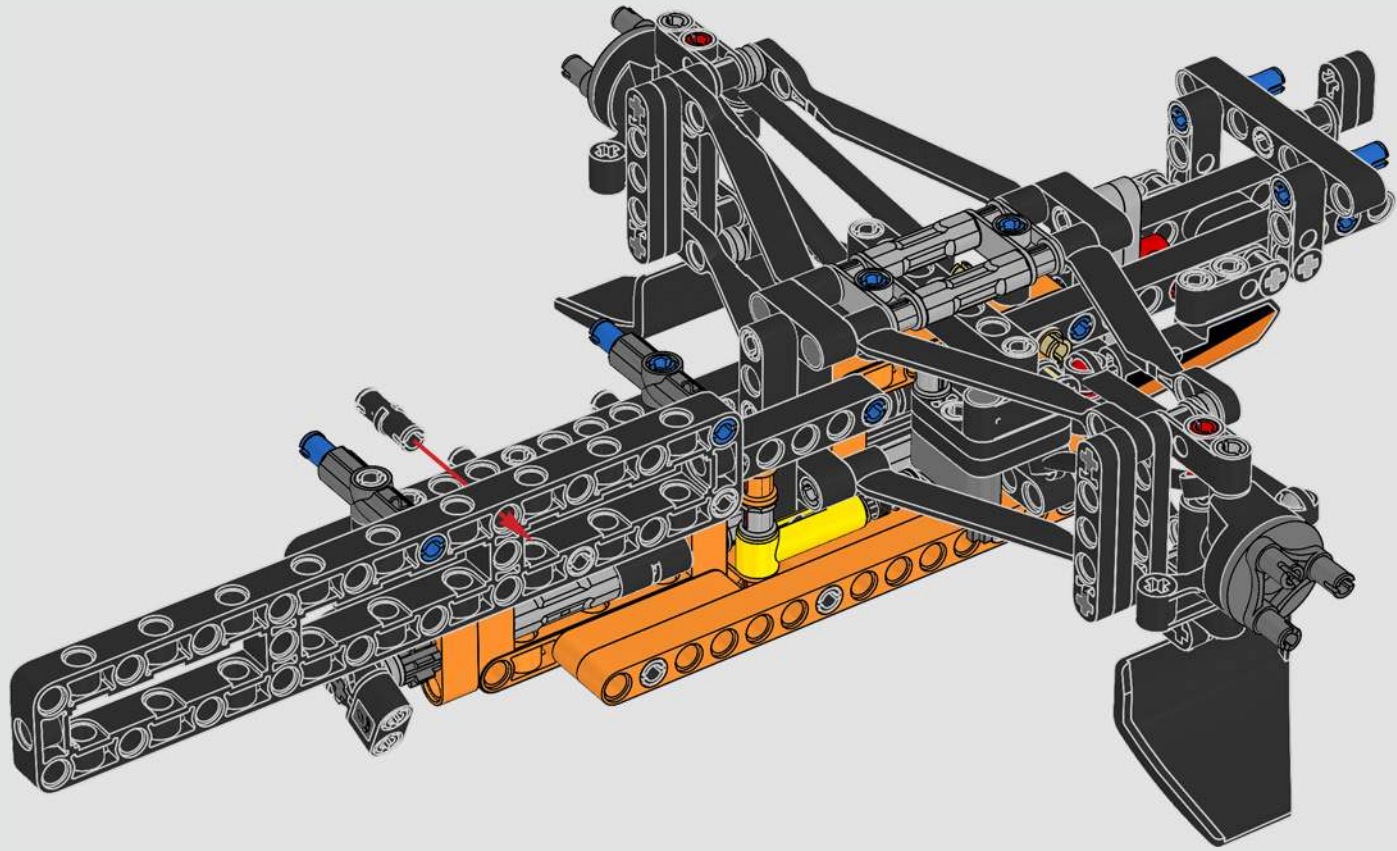

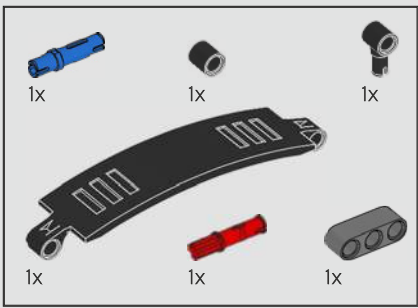

135

1

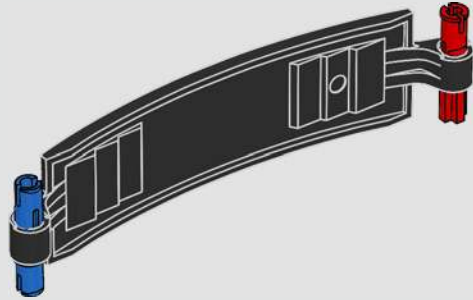

2

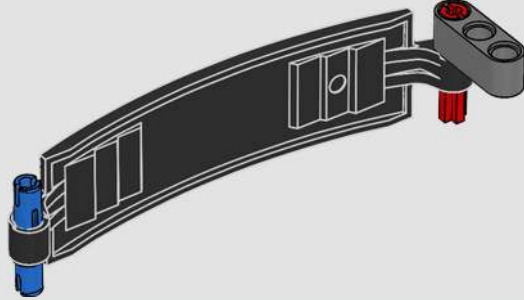

3

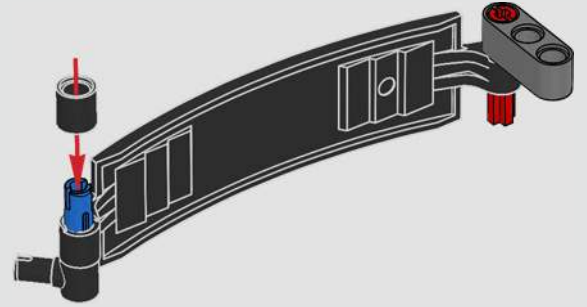

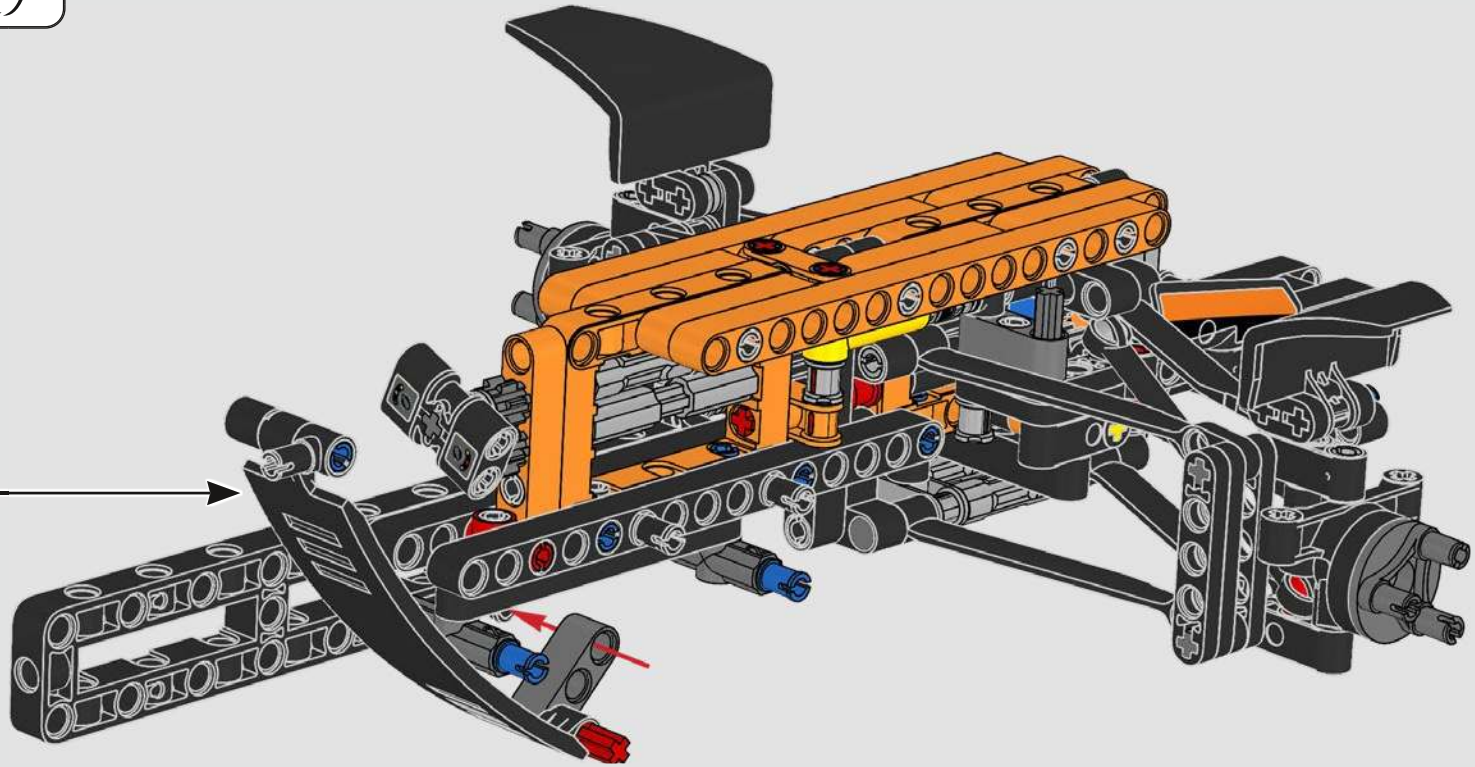

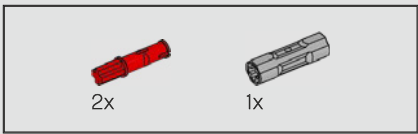

136

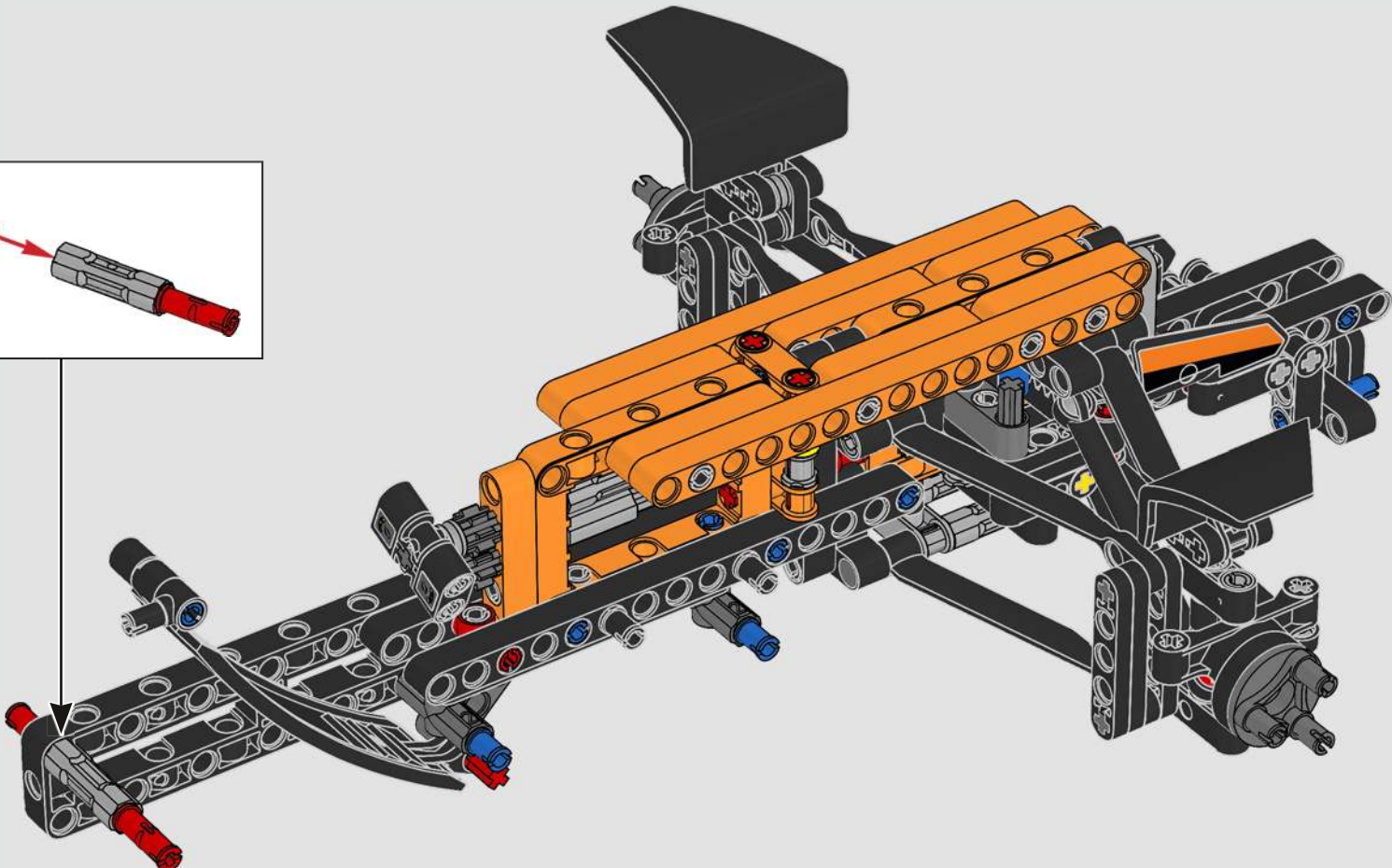
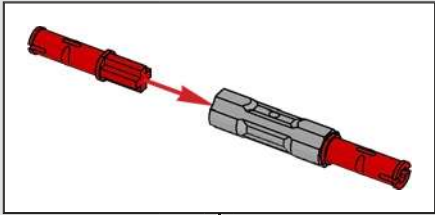

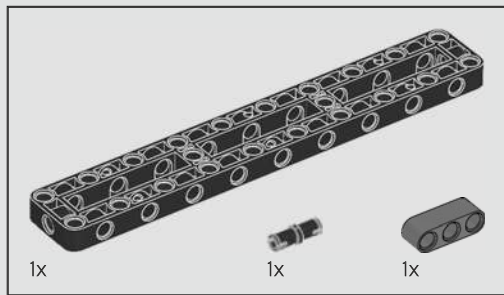

137

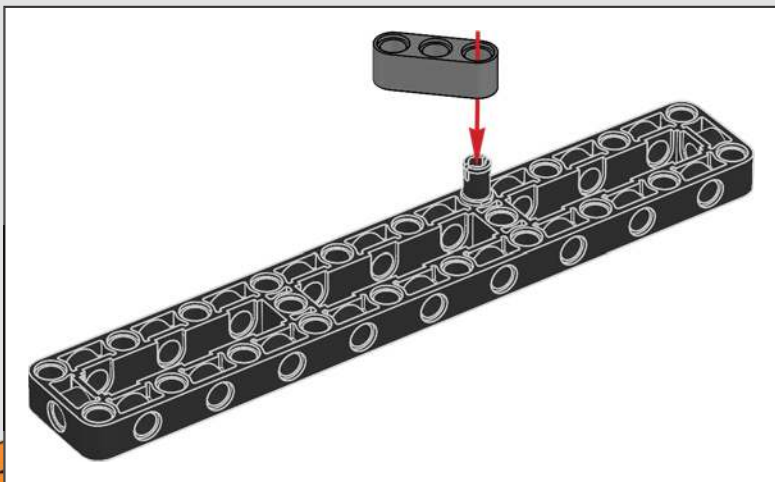
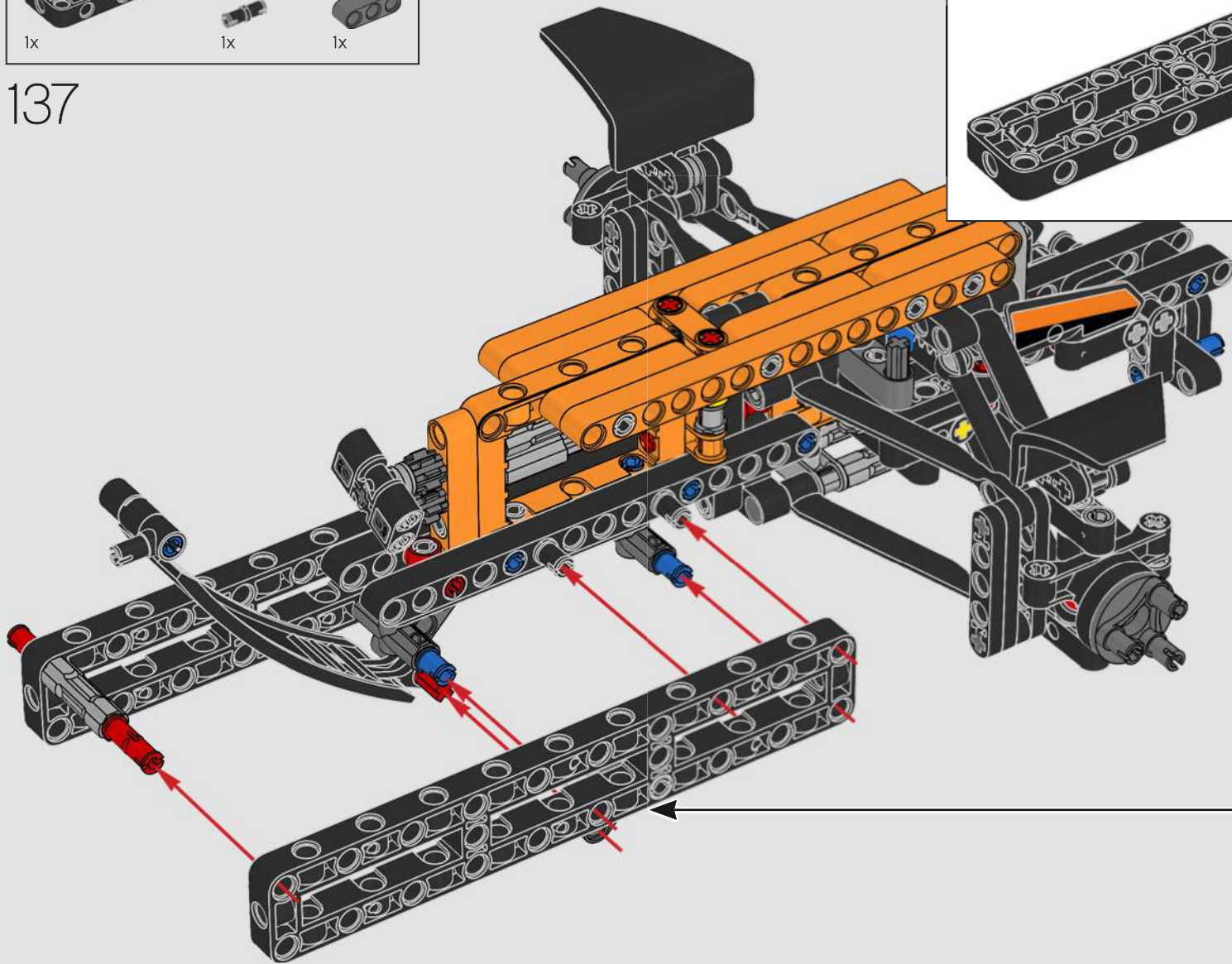

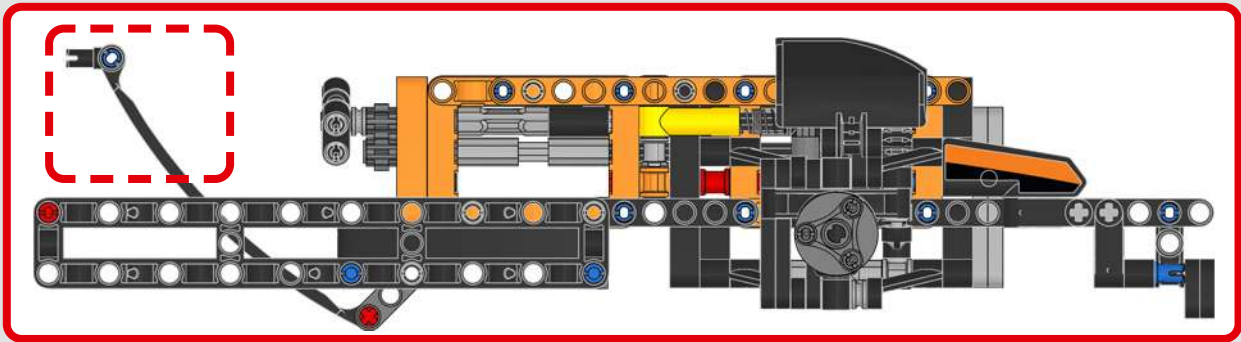

138

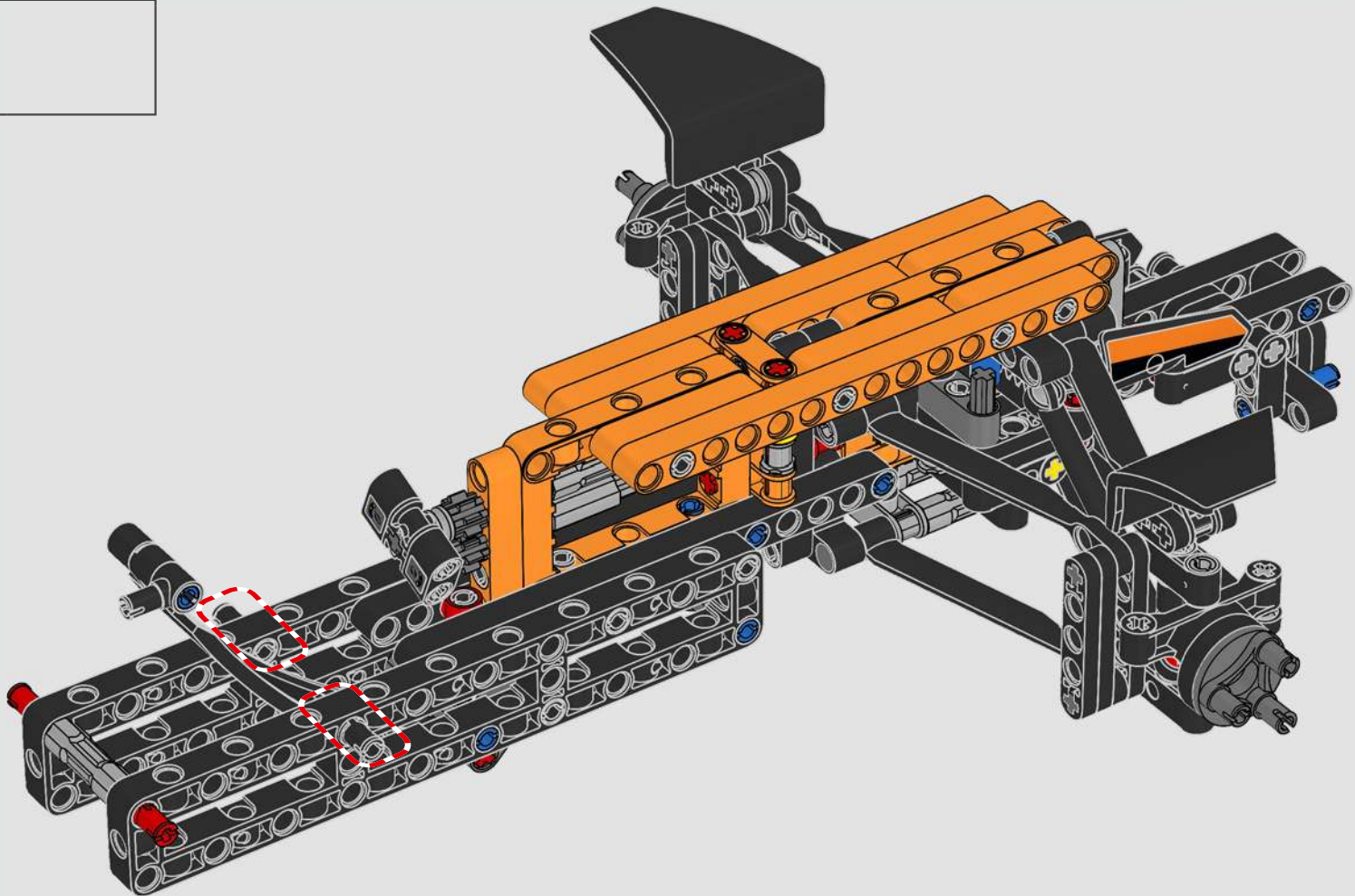

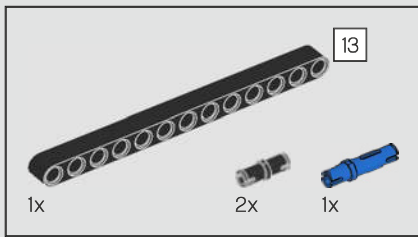

139

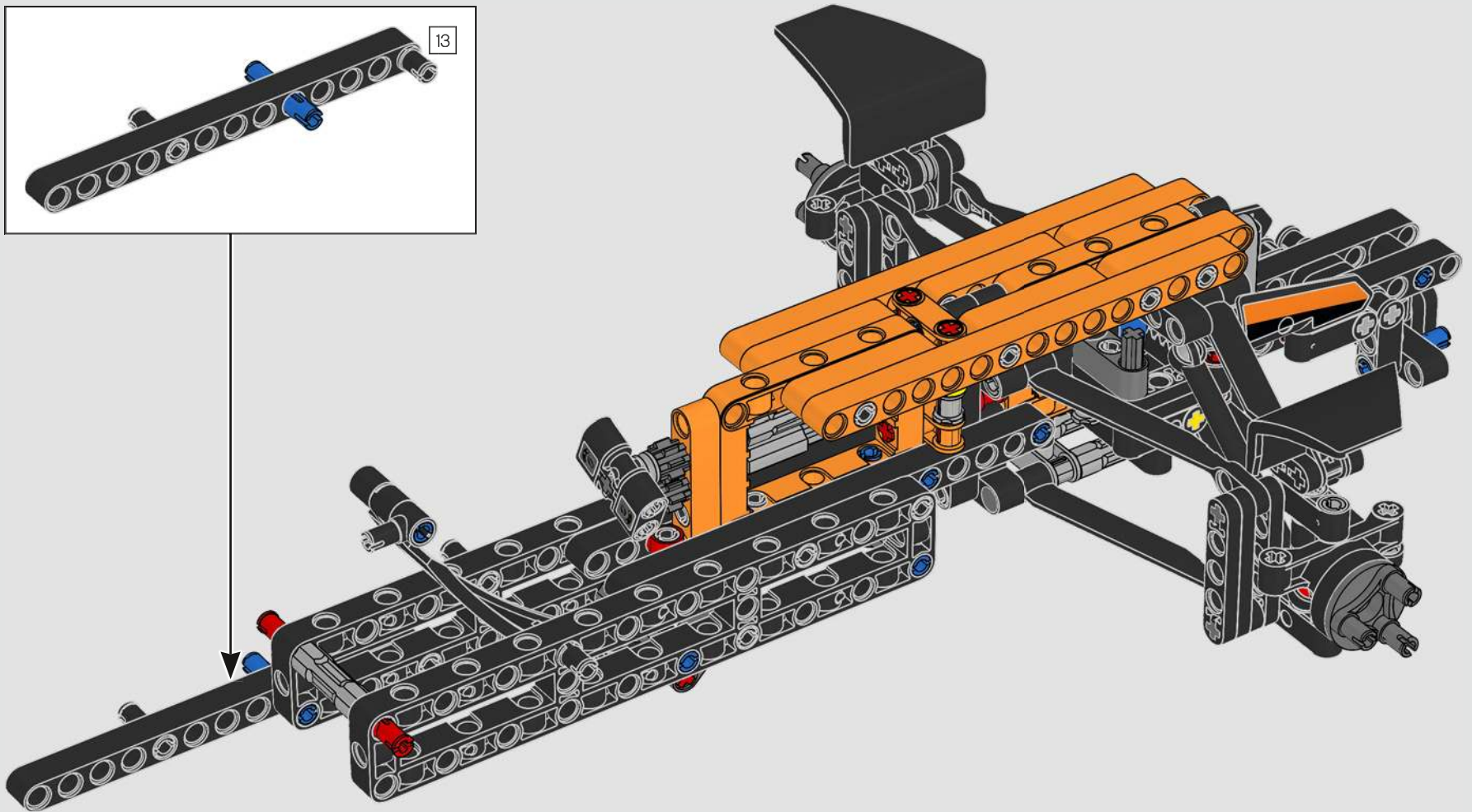
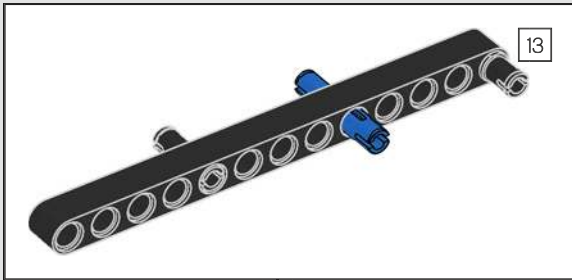

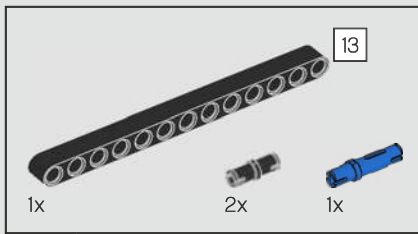

140

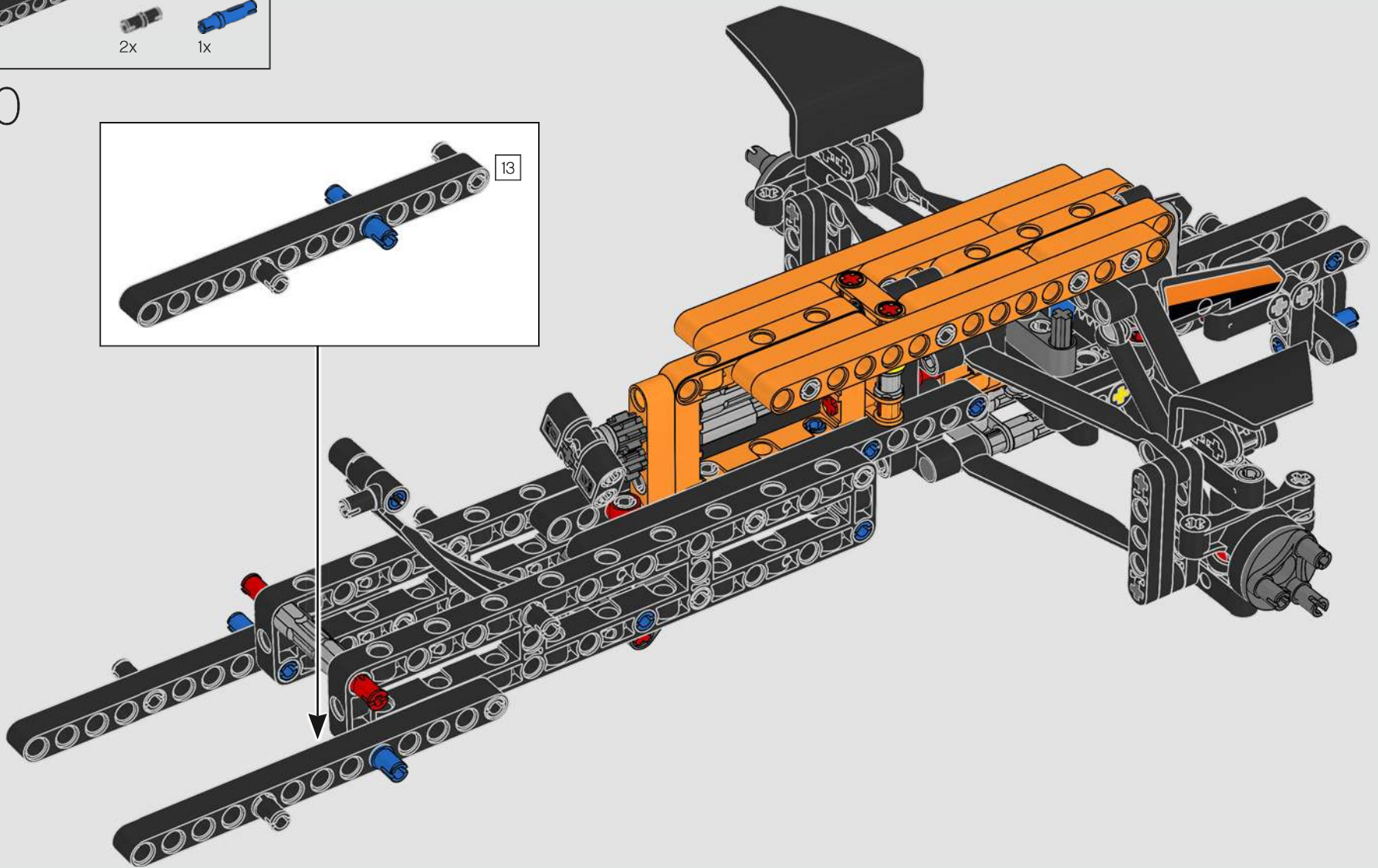
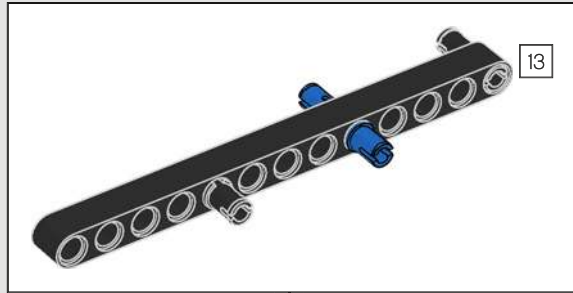

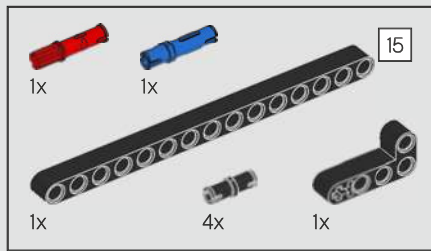

141

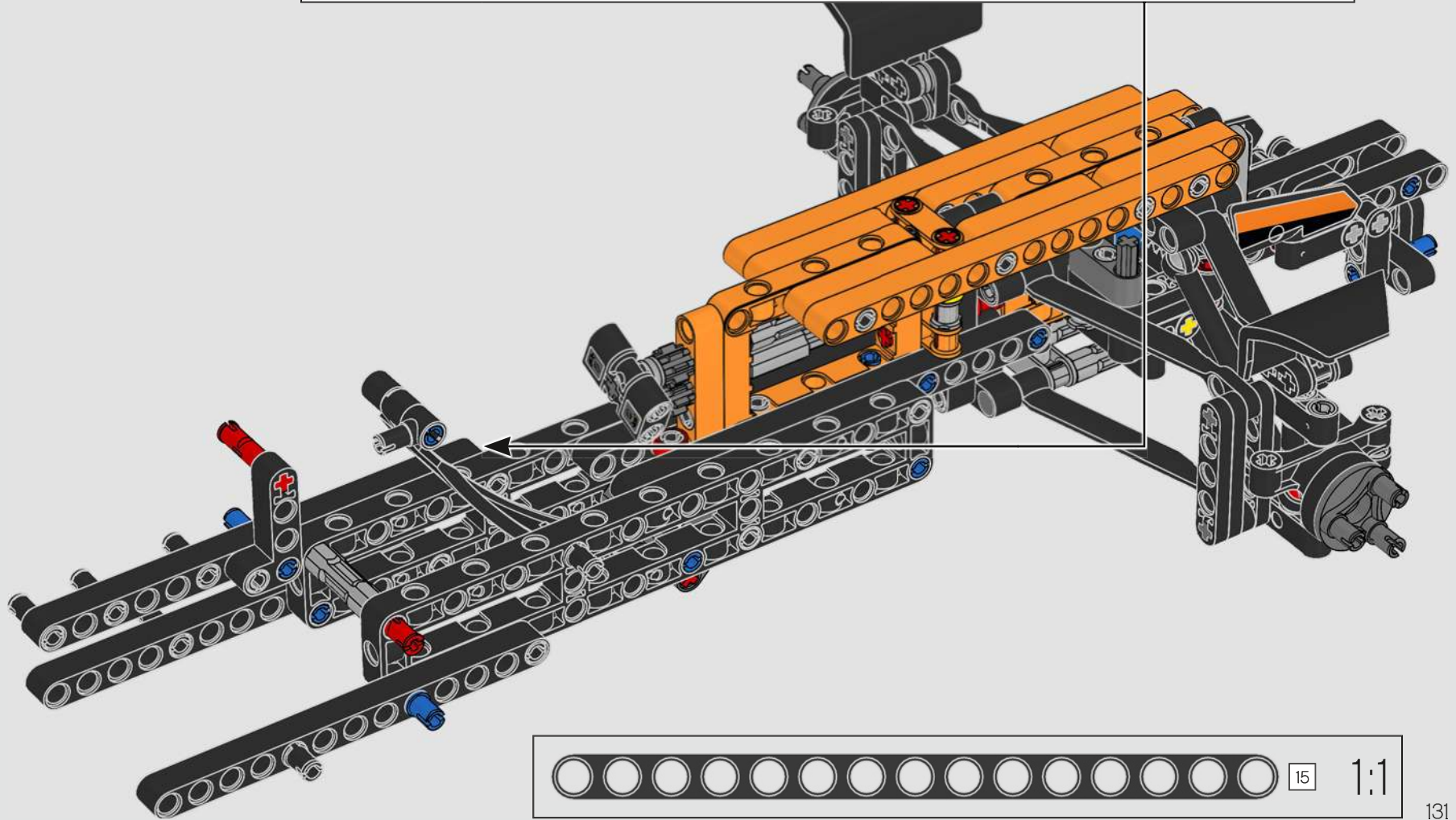
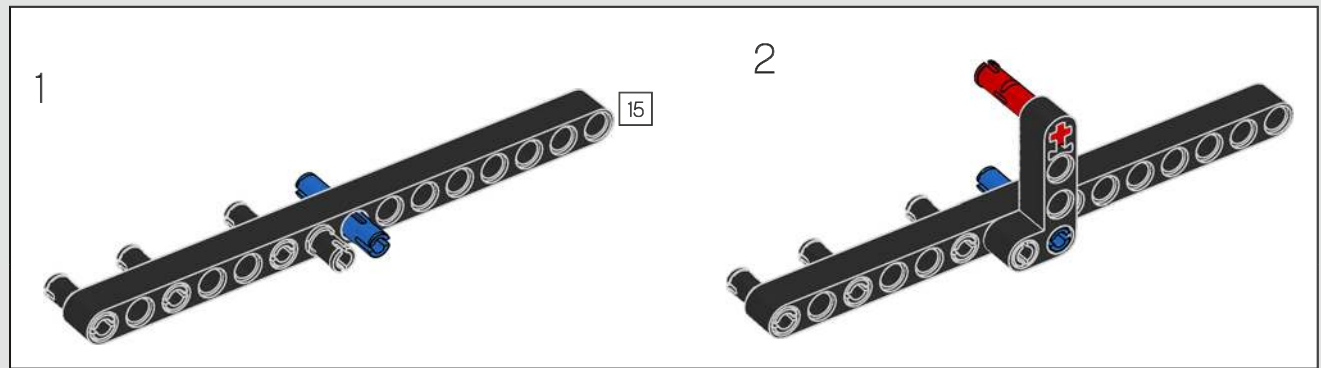

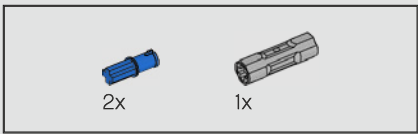

142

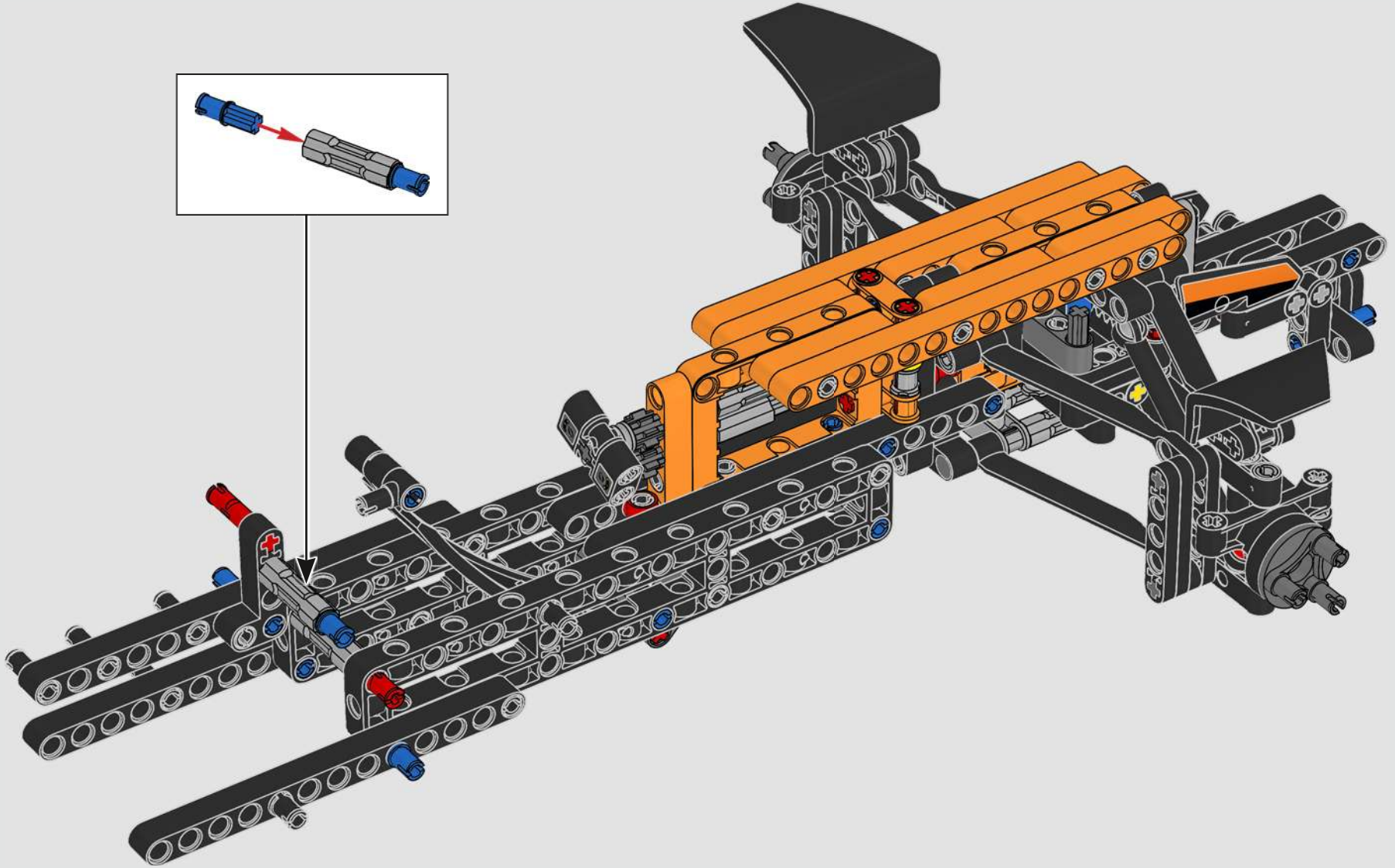
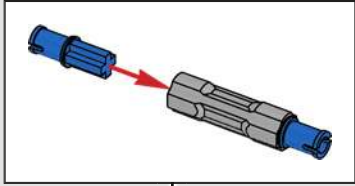

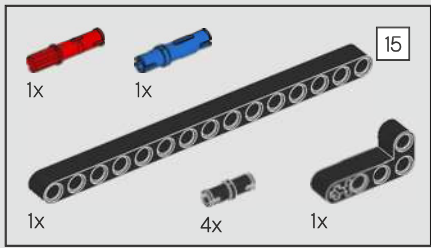

143

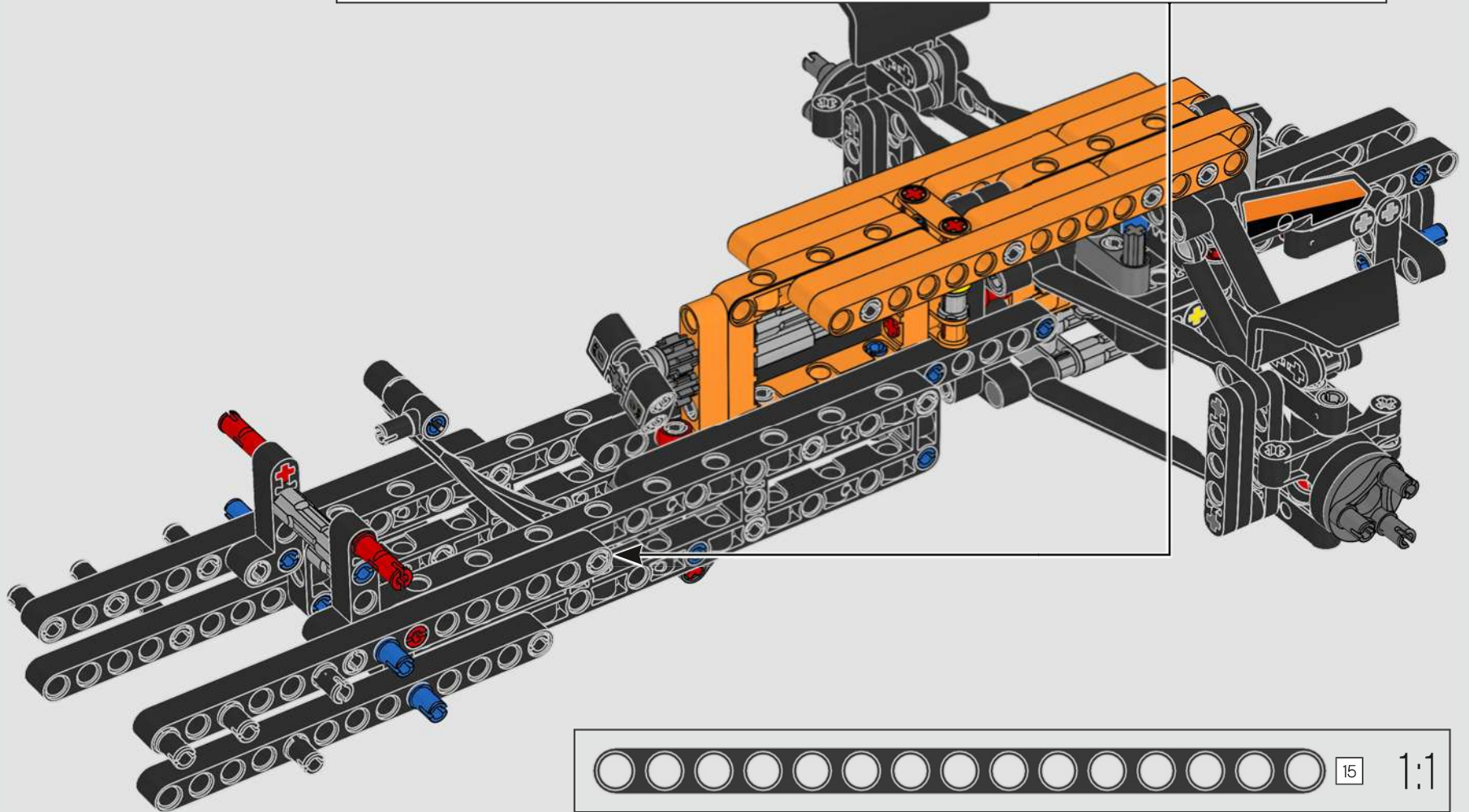
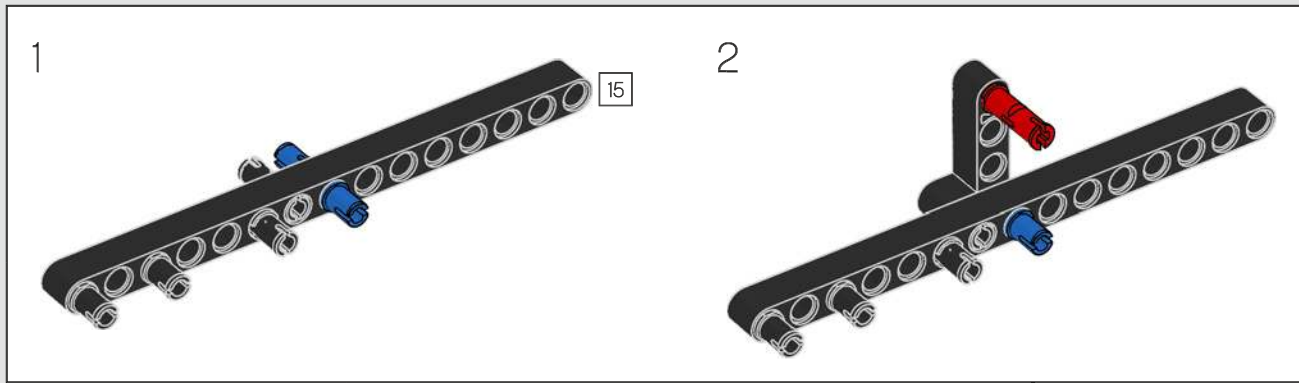

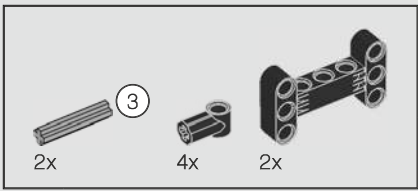

144

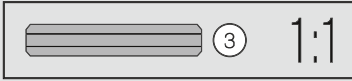
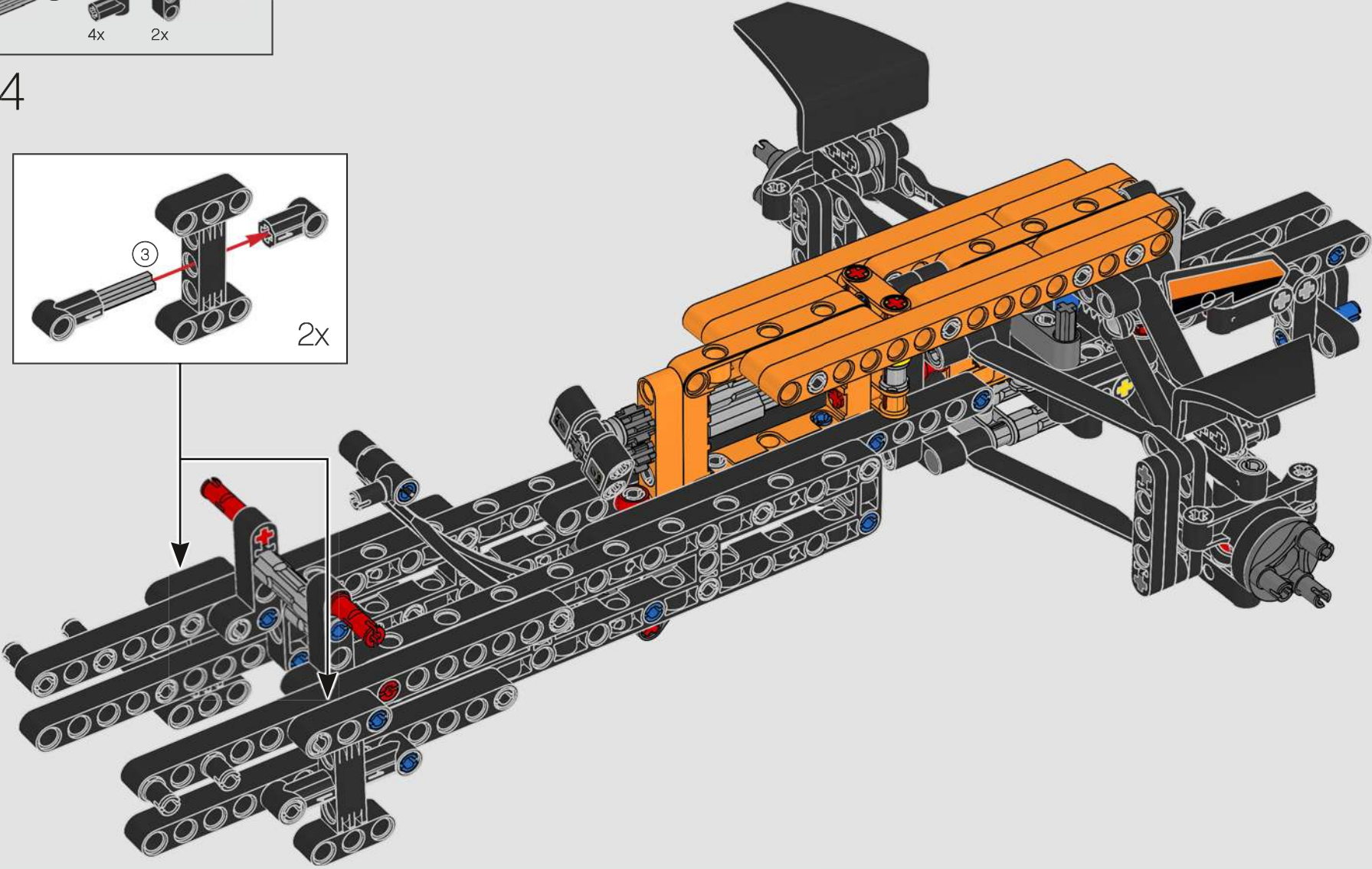
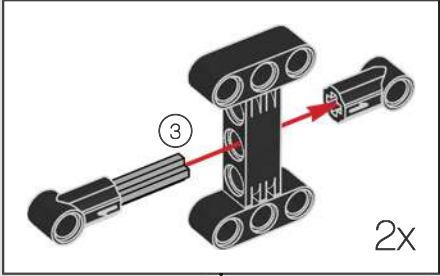

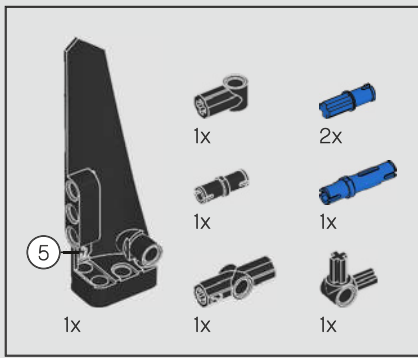

145

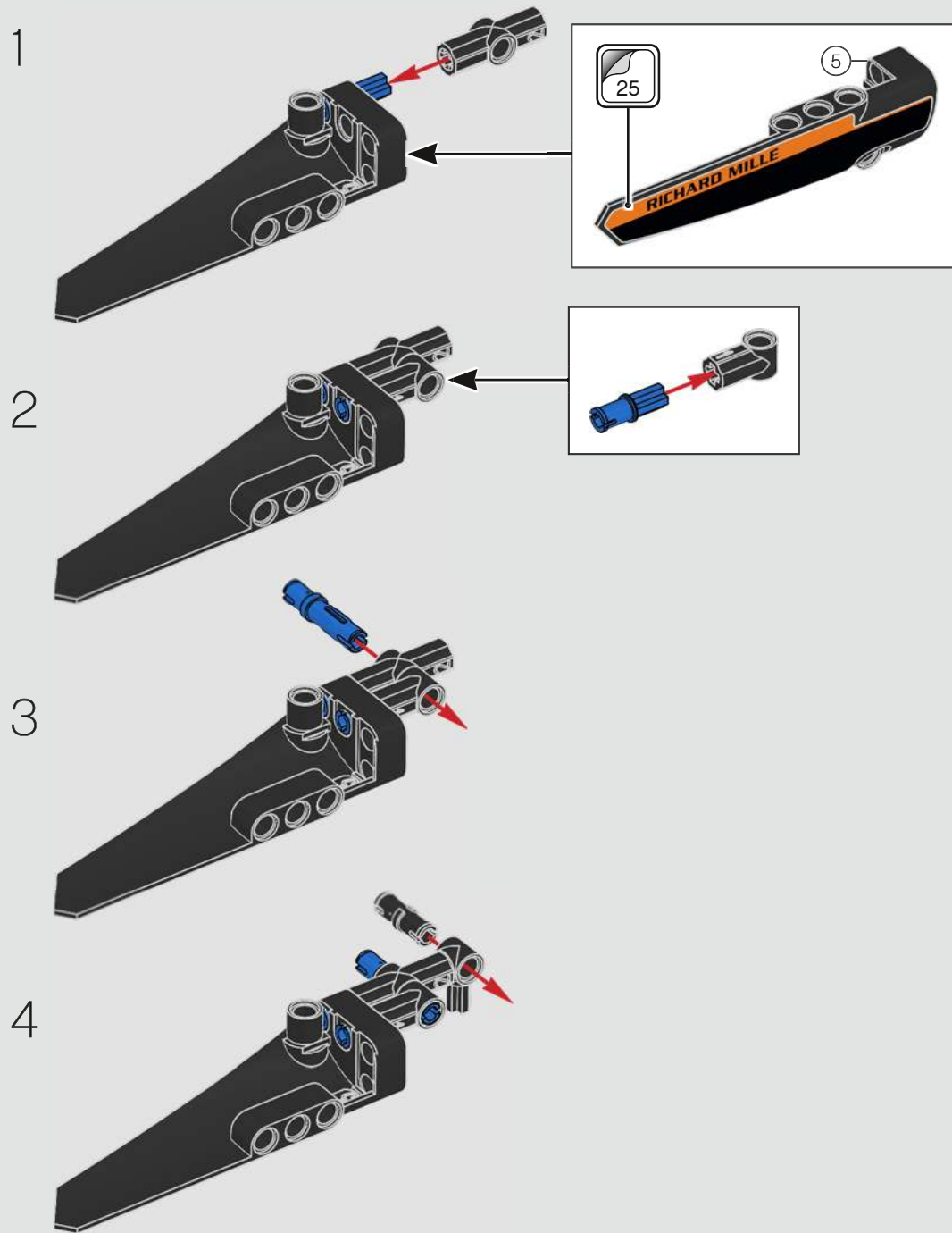

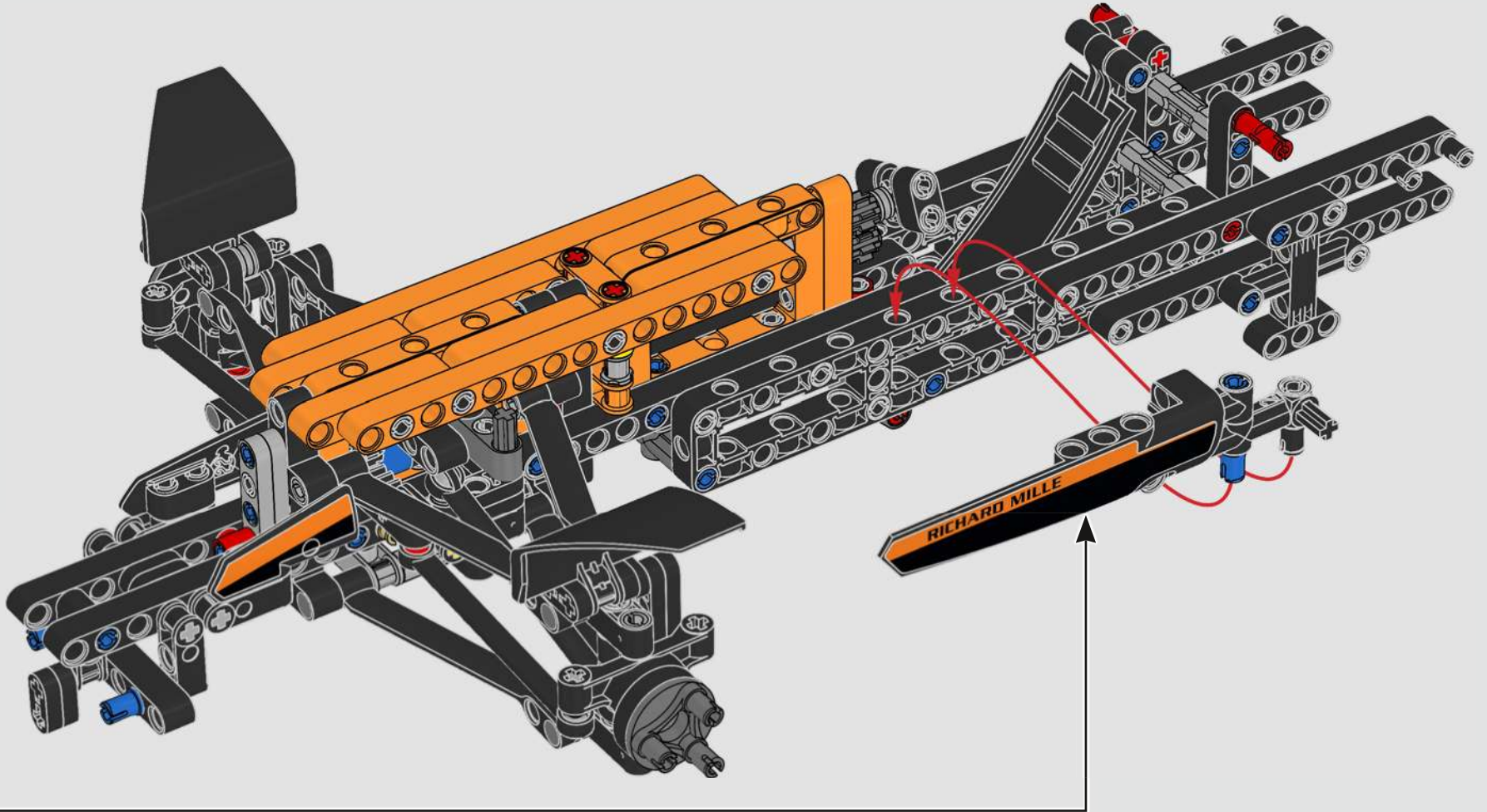

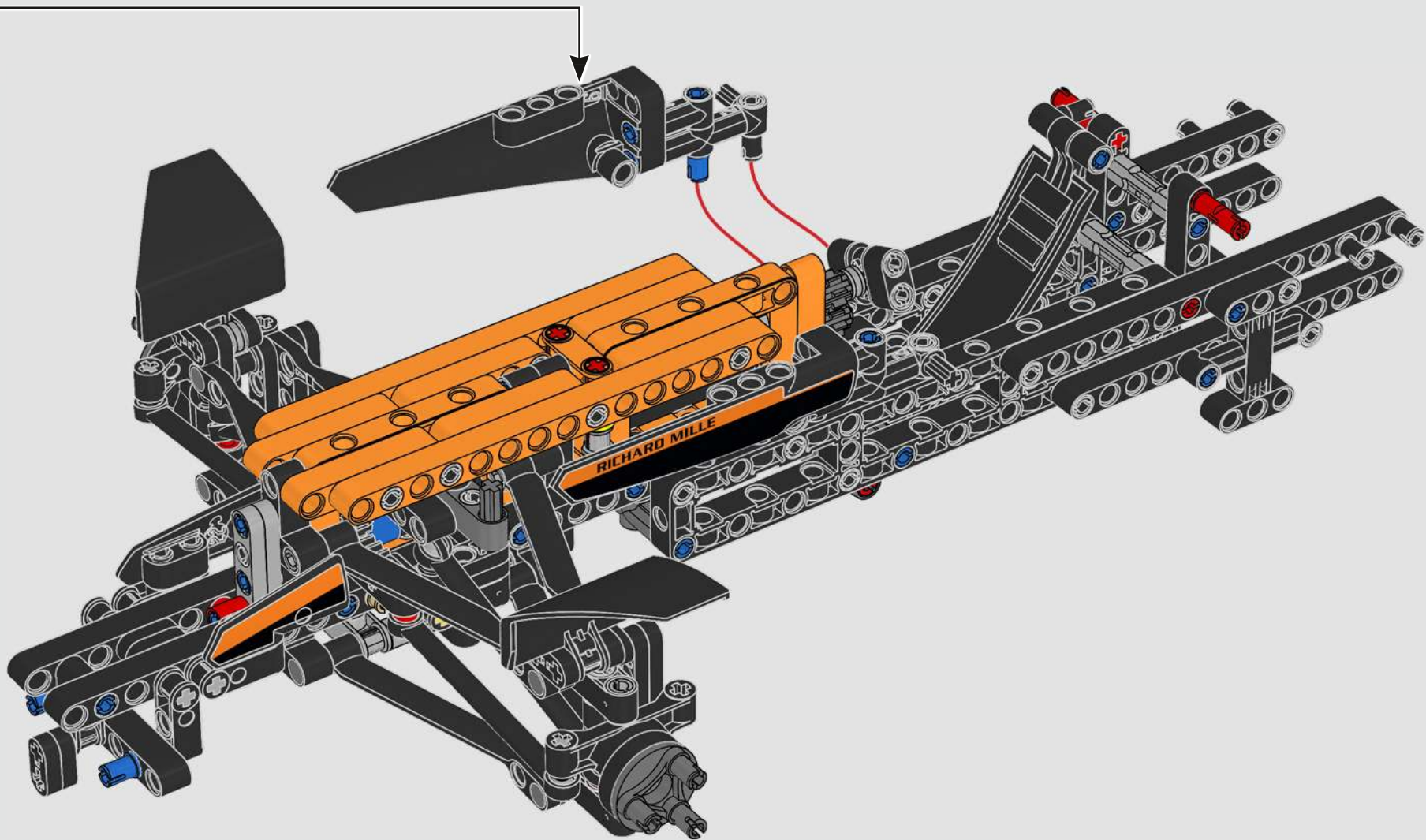

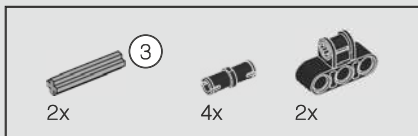

147

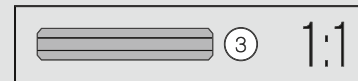
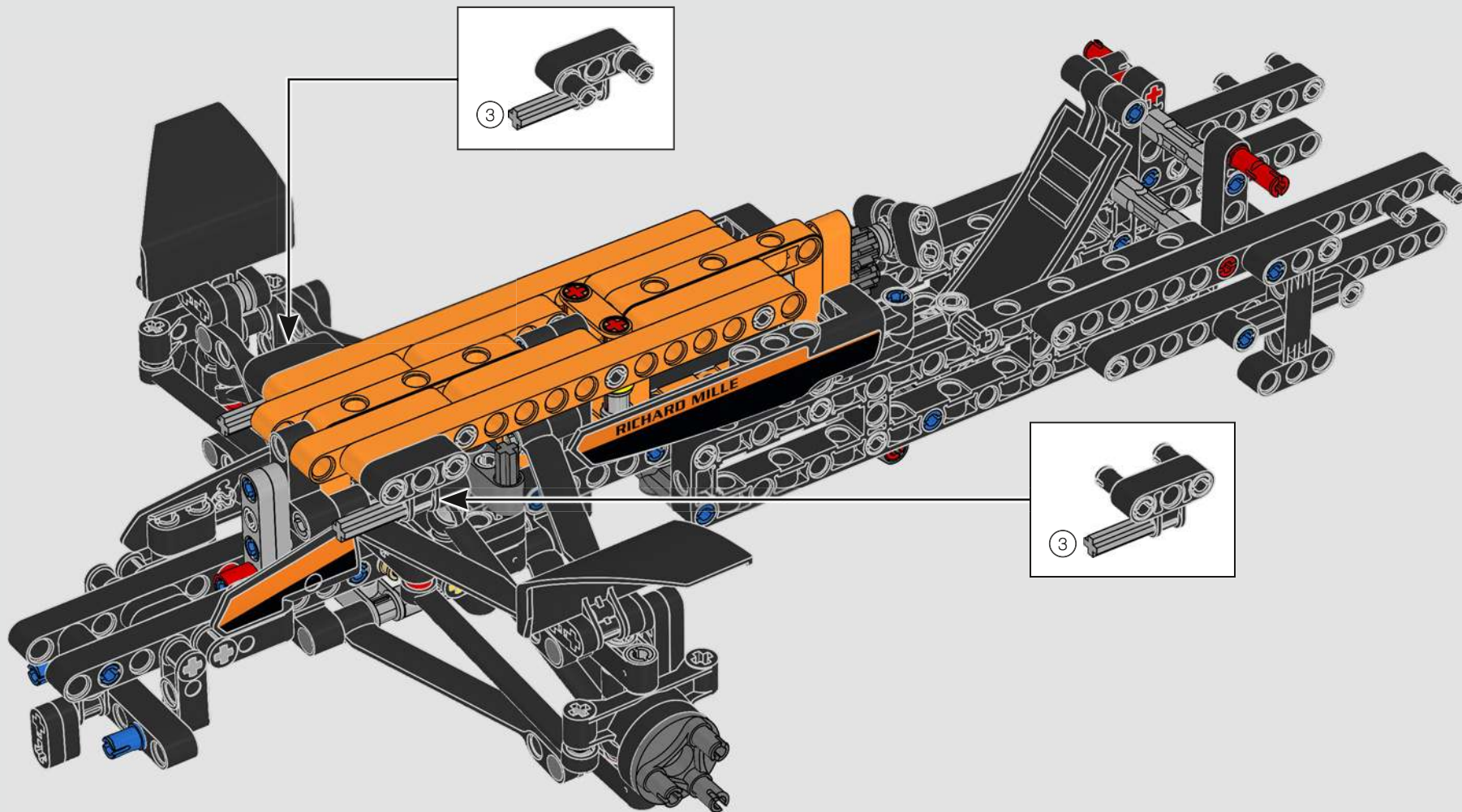



2x



1:1

148



2x

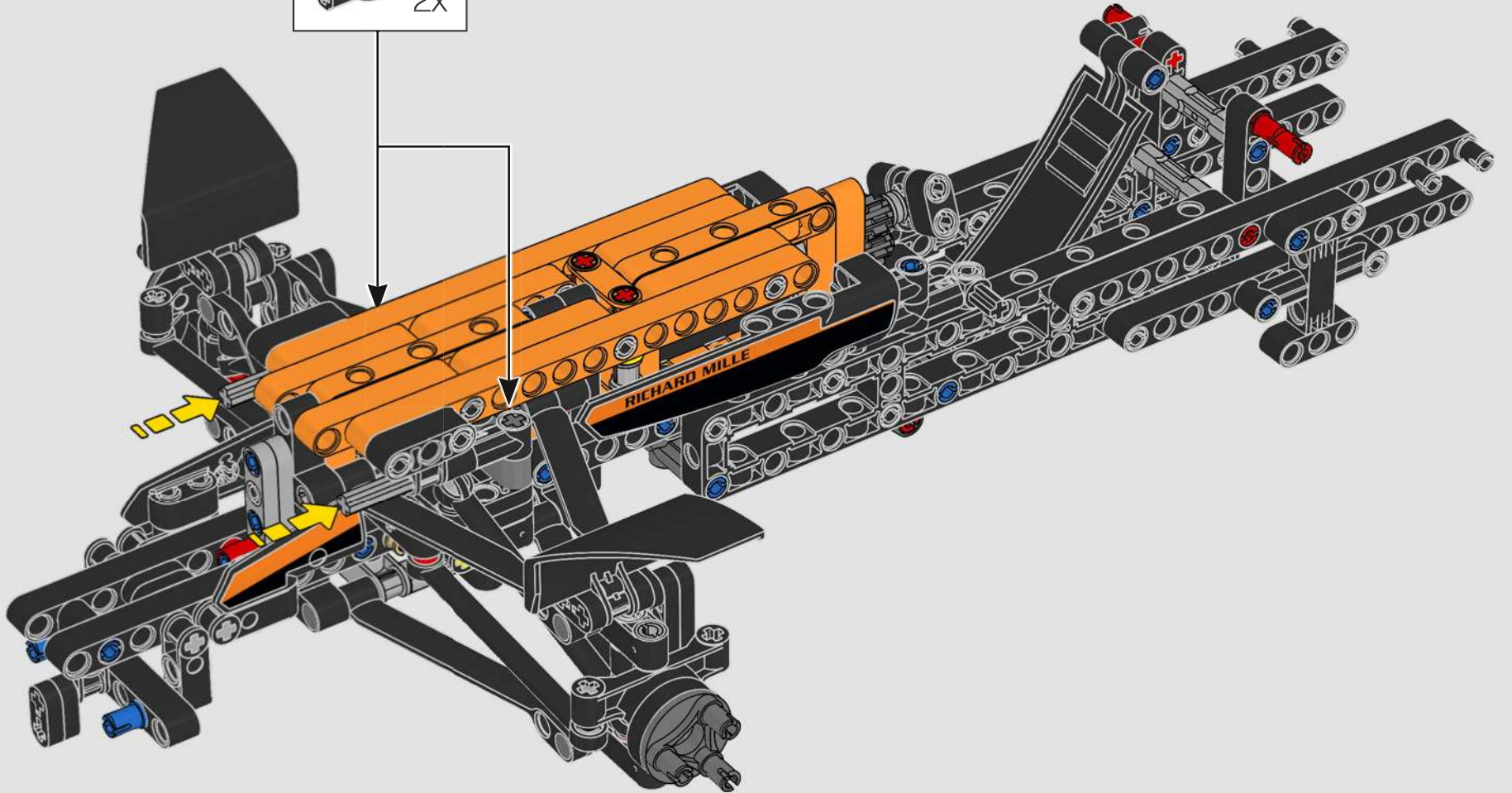

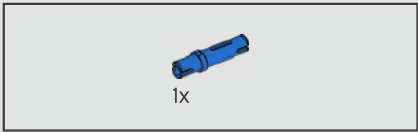

149

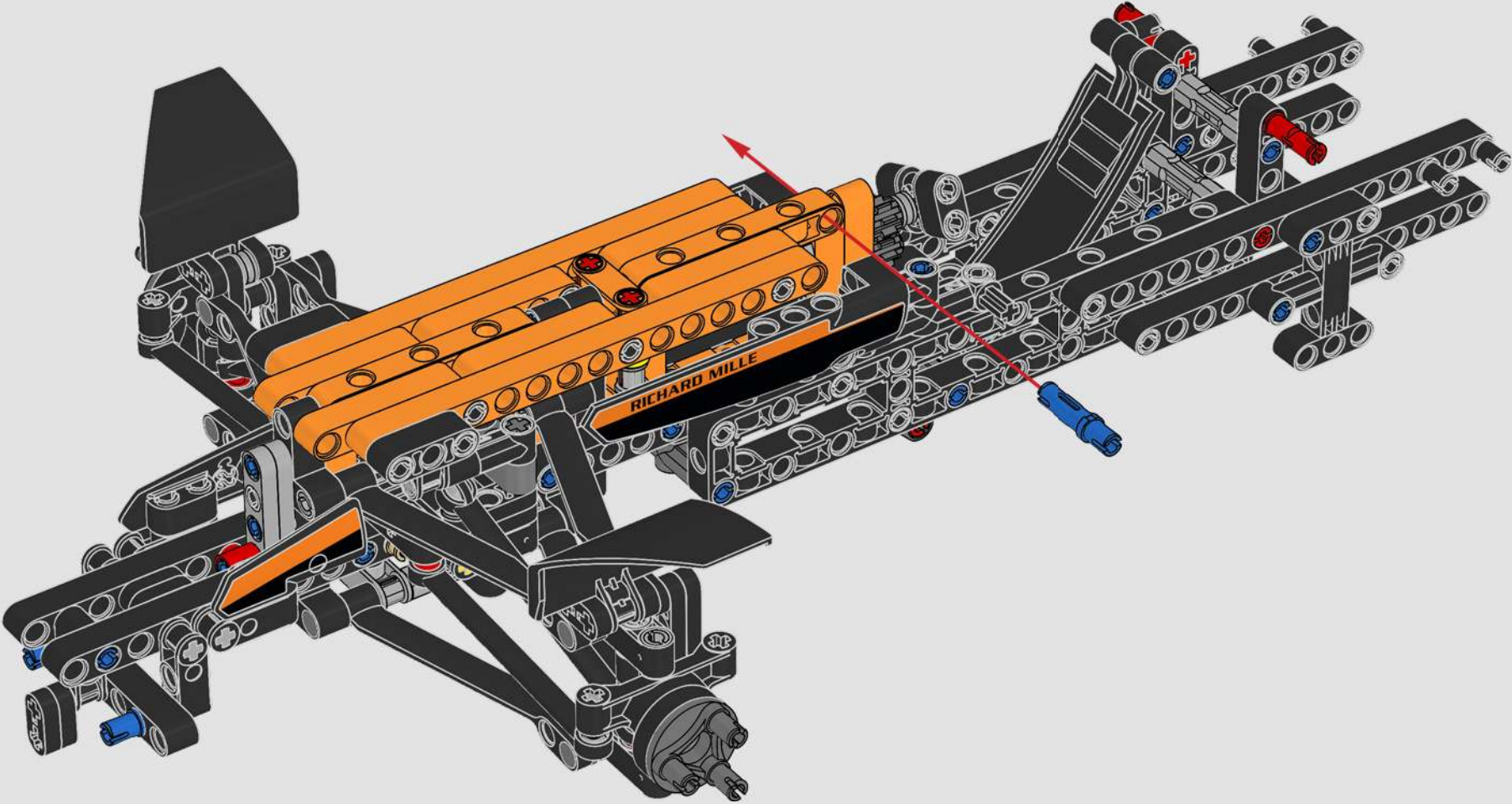

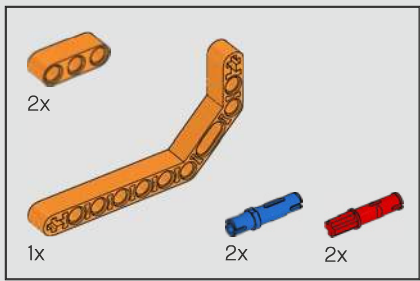

150

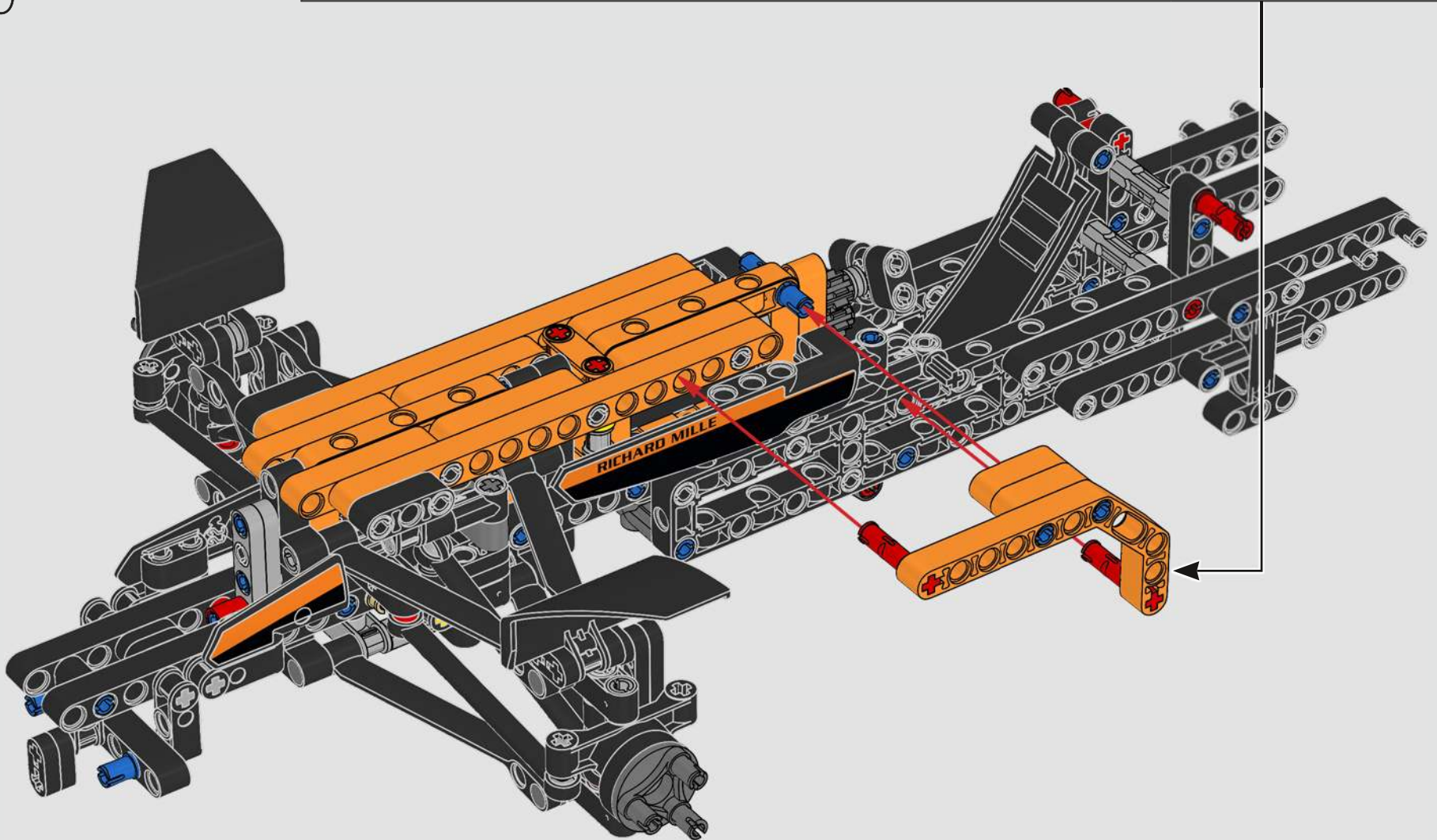
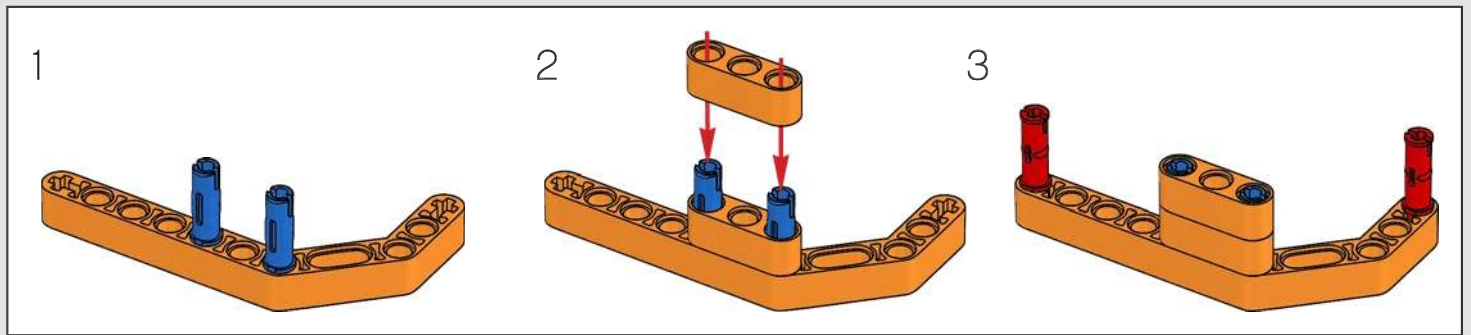

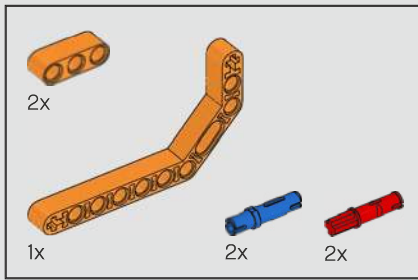

151

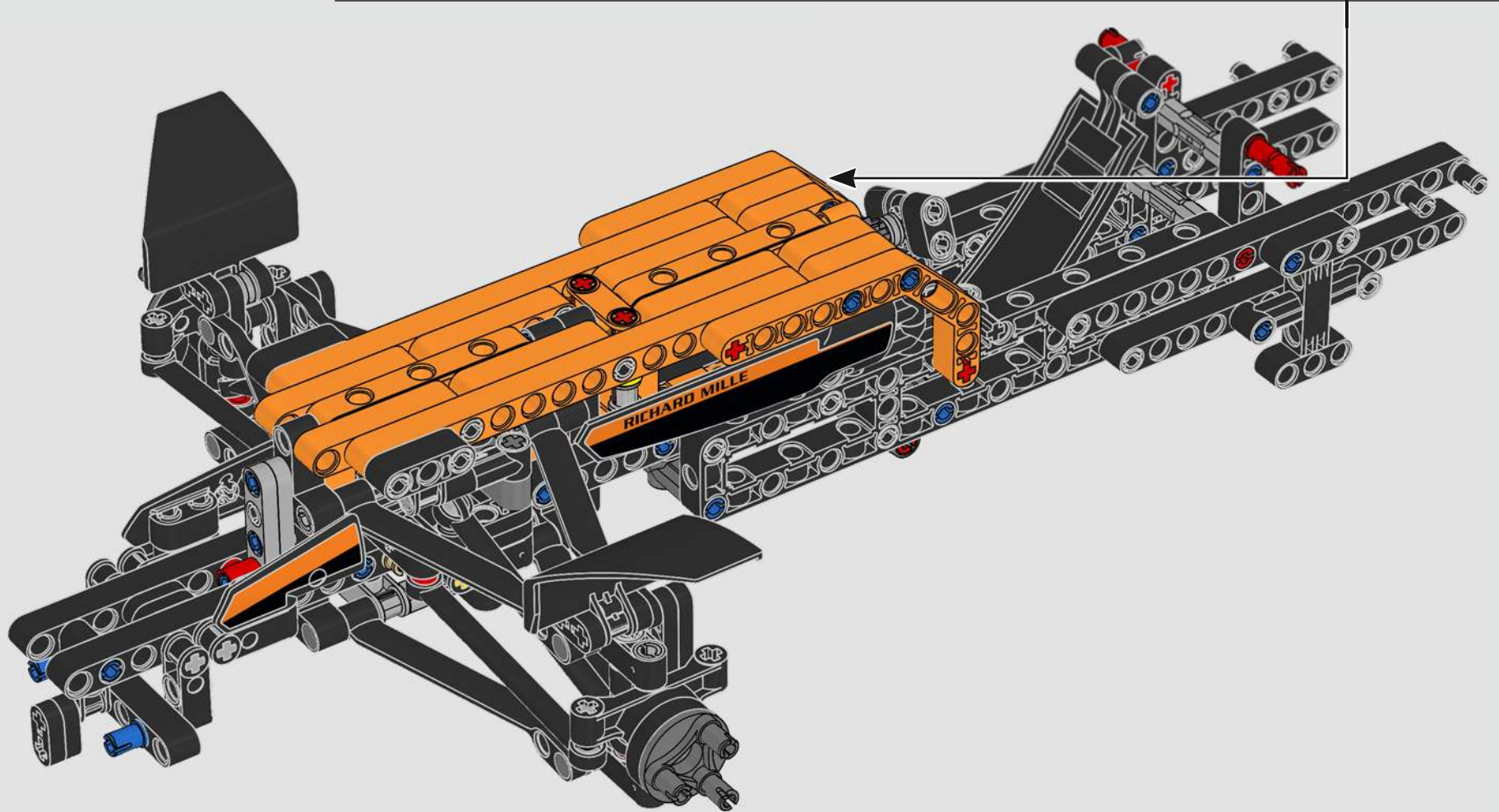
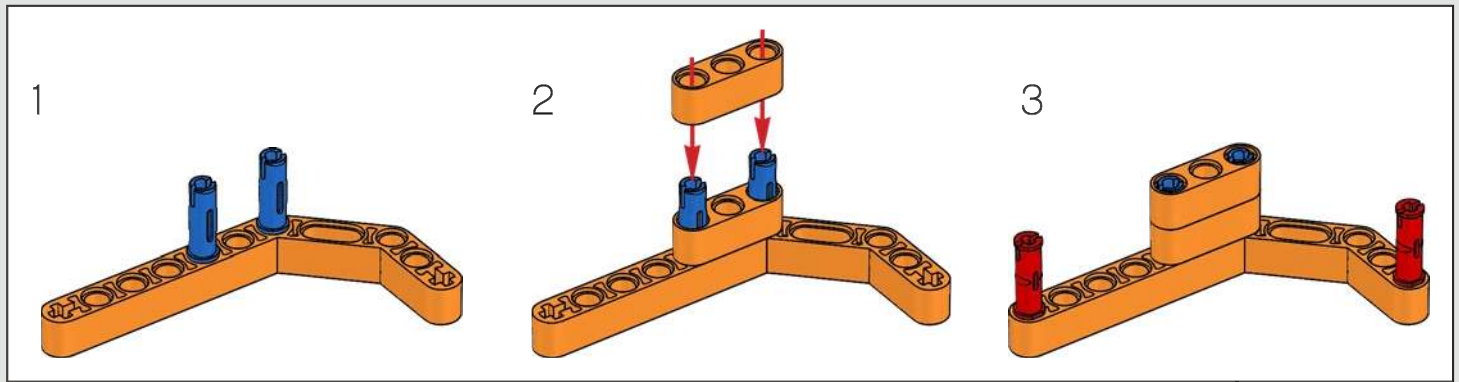



4x

152

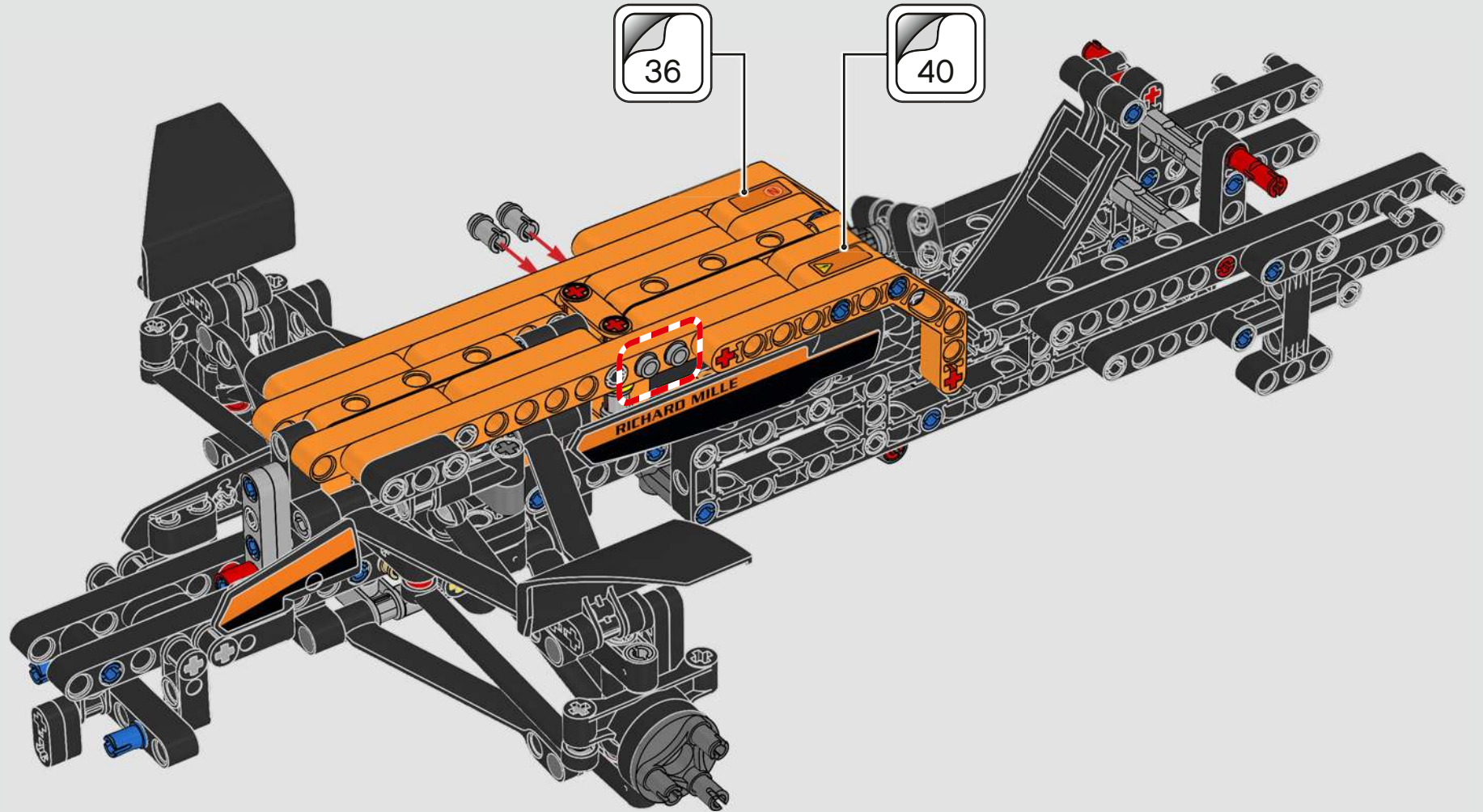

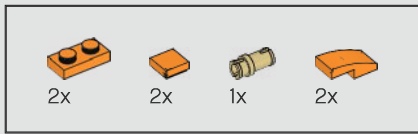

153

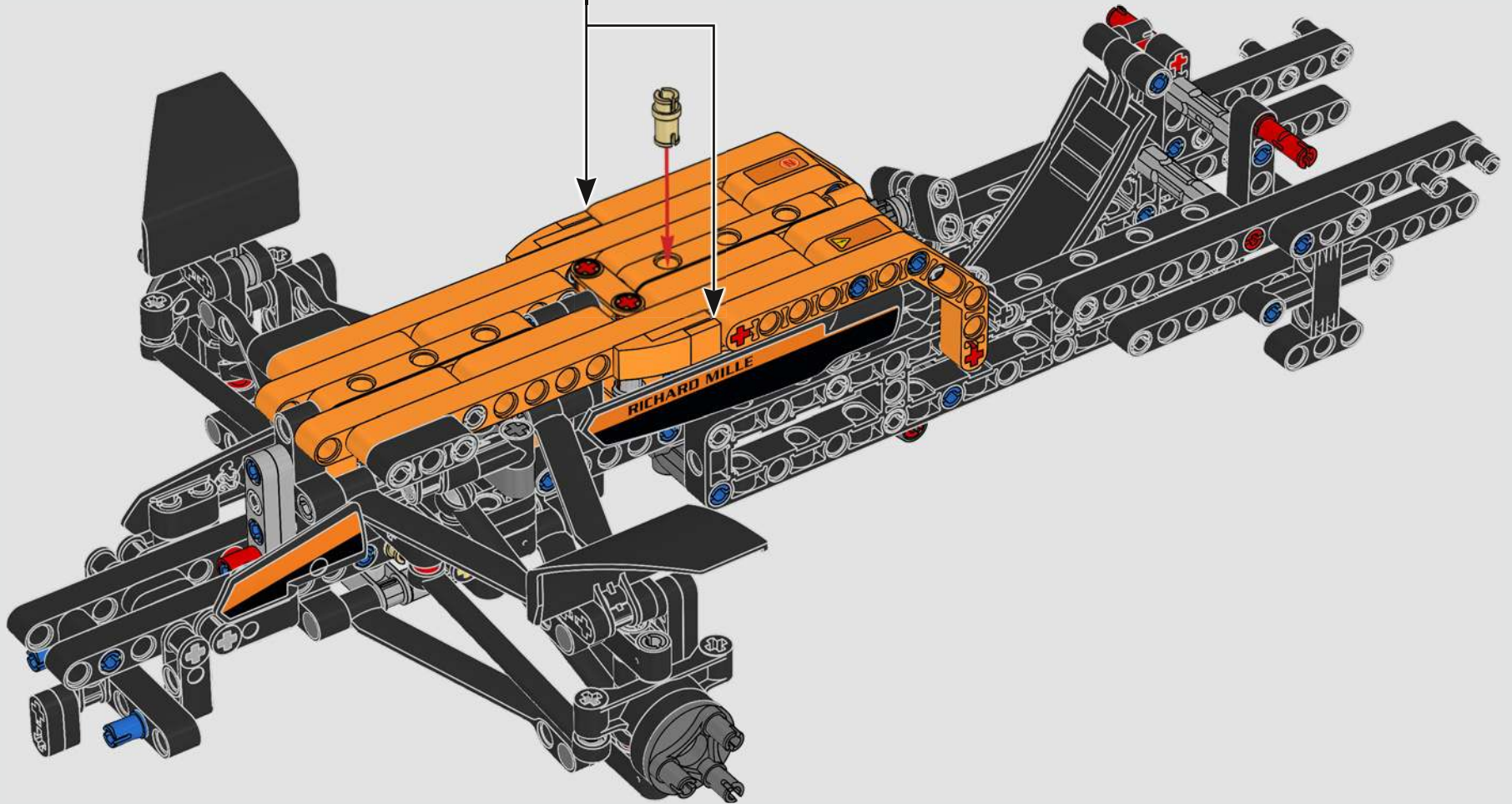
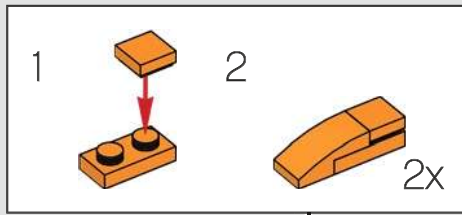

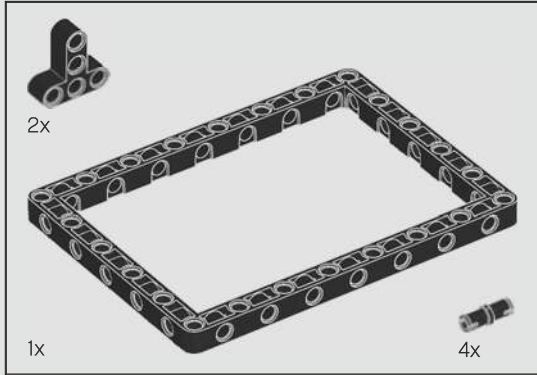
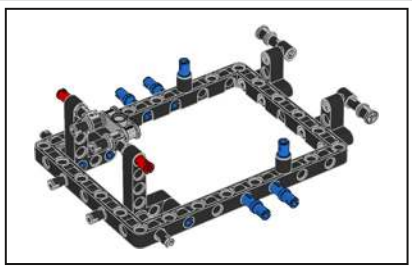

154

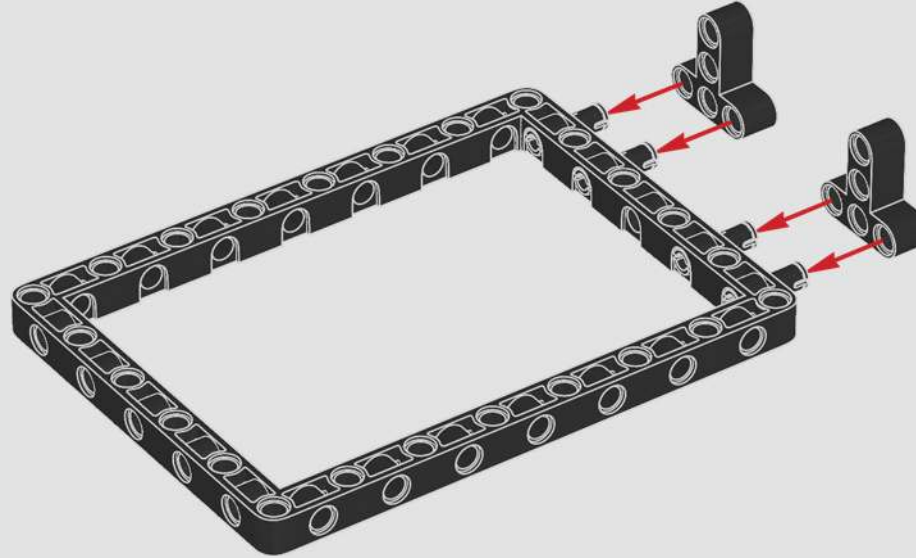



155

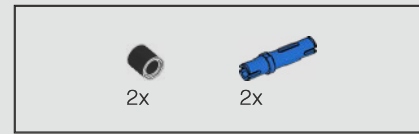
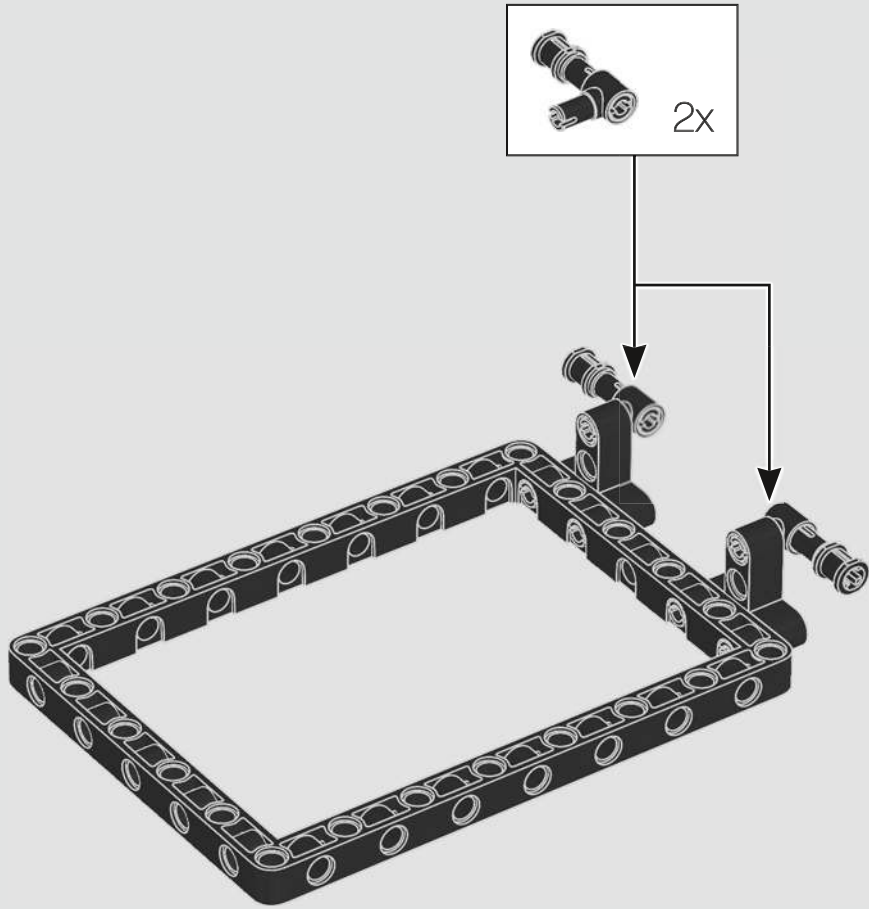

156

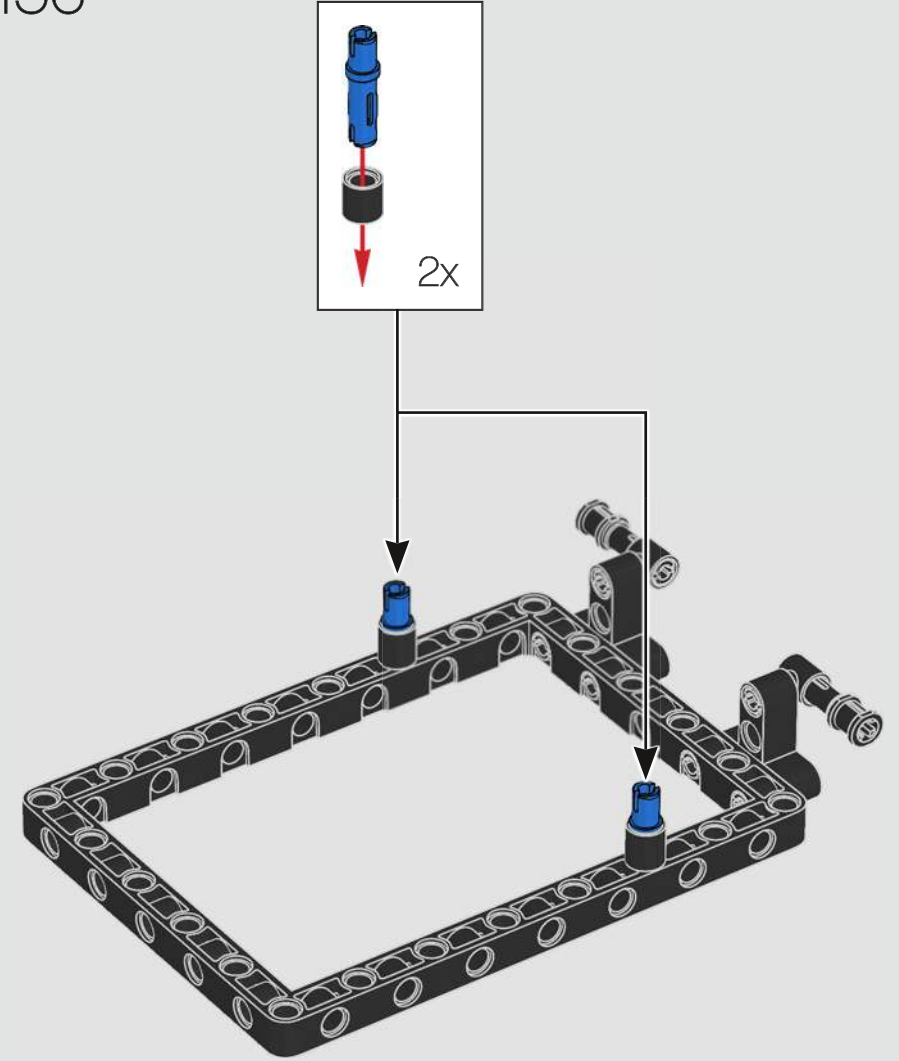

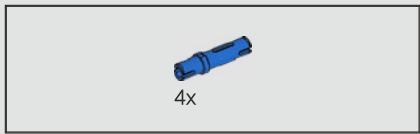

157

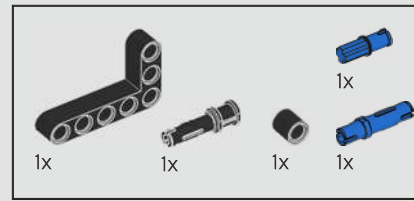
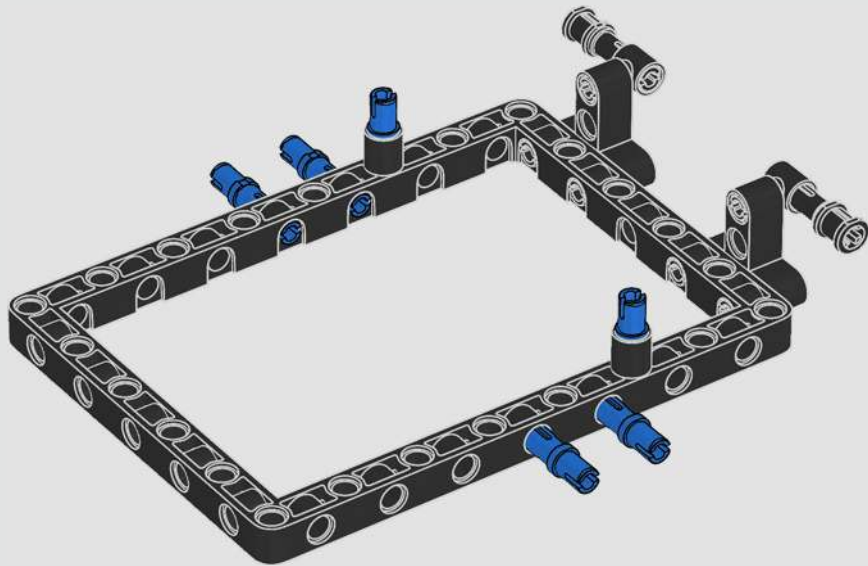

158

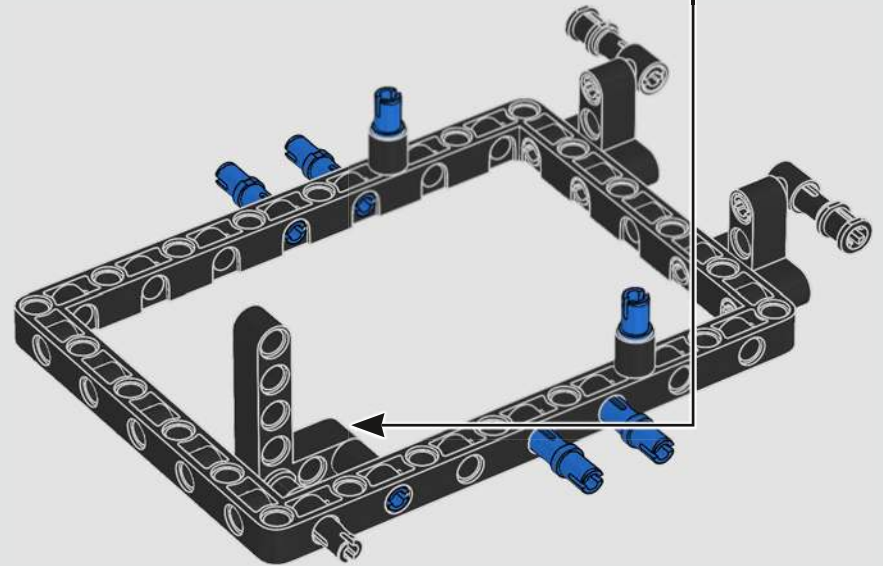
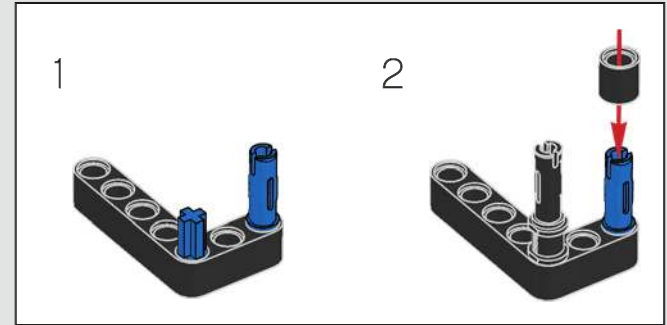

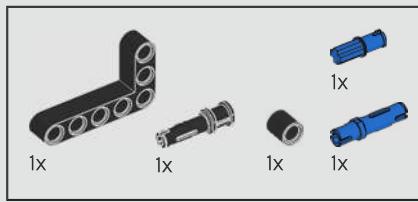

159

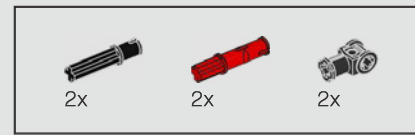
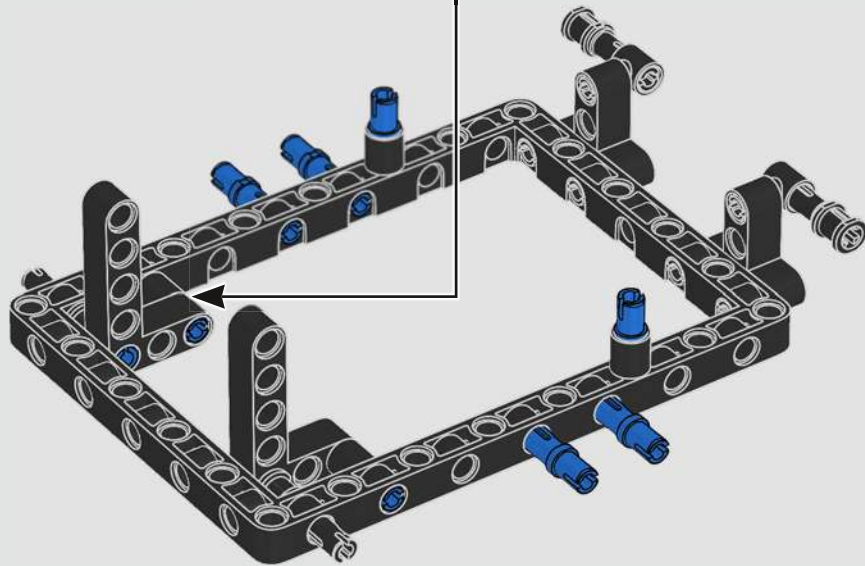
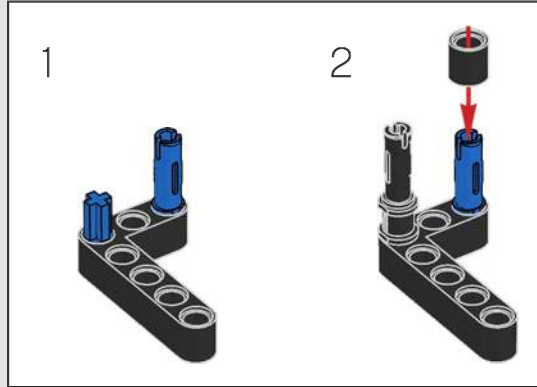

160

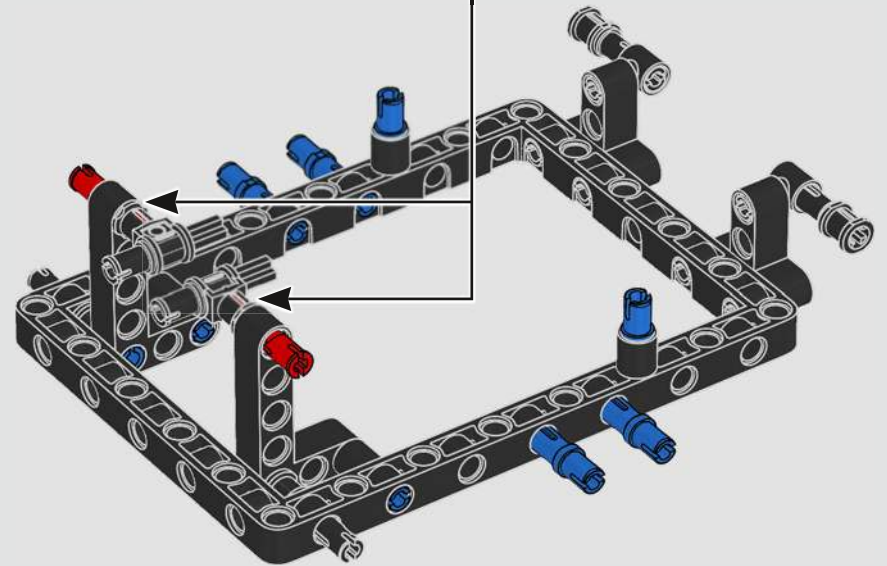
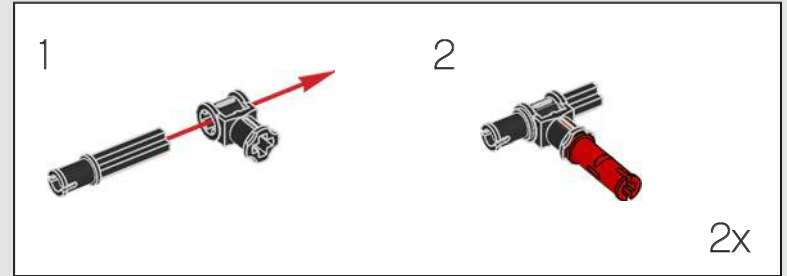

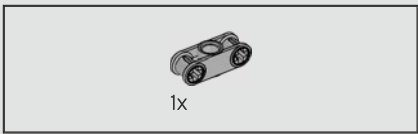

161

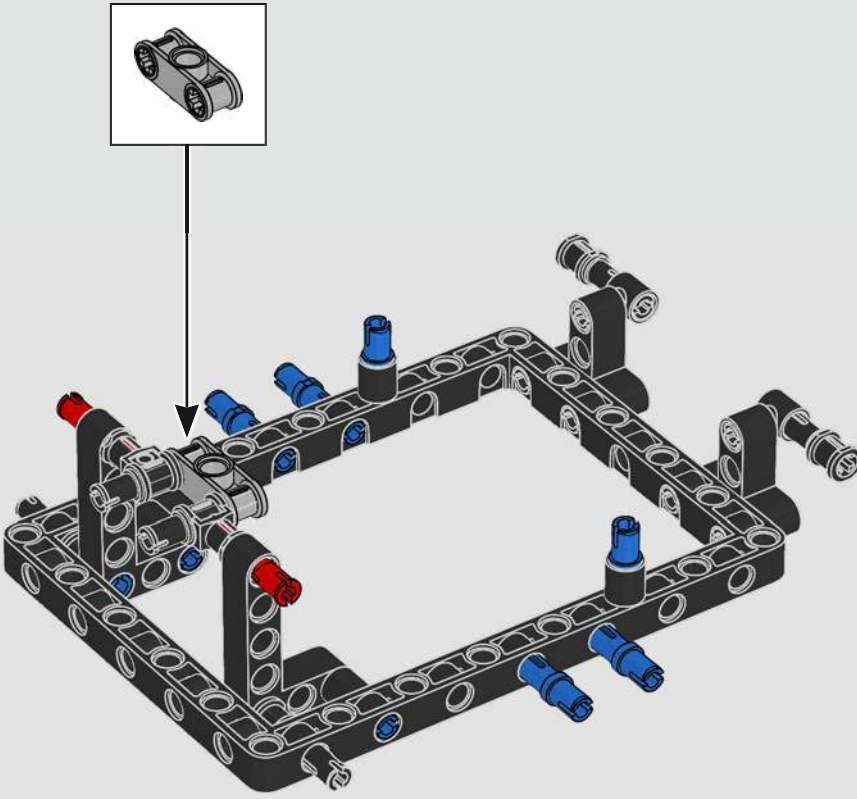

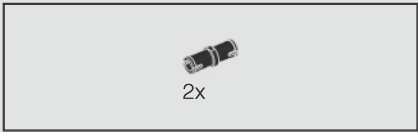

162

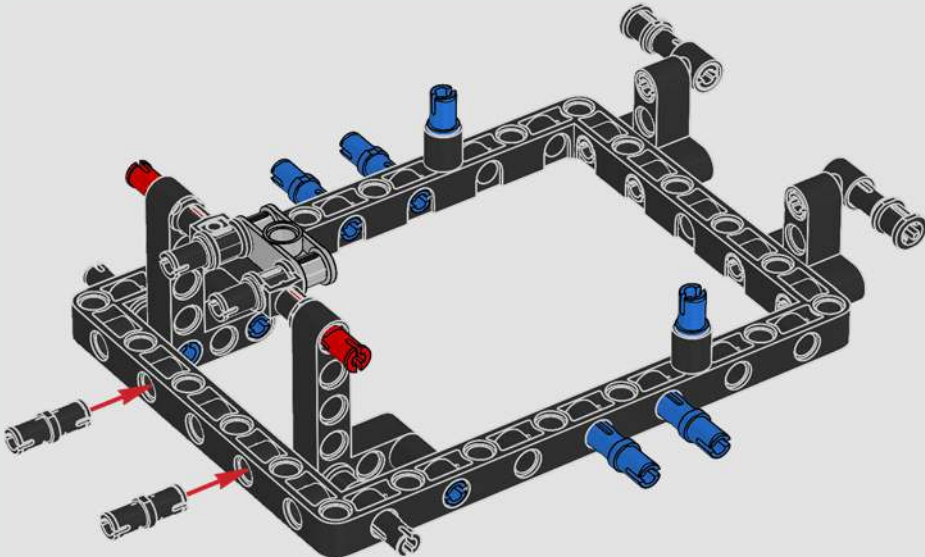

163

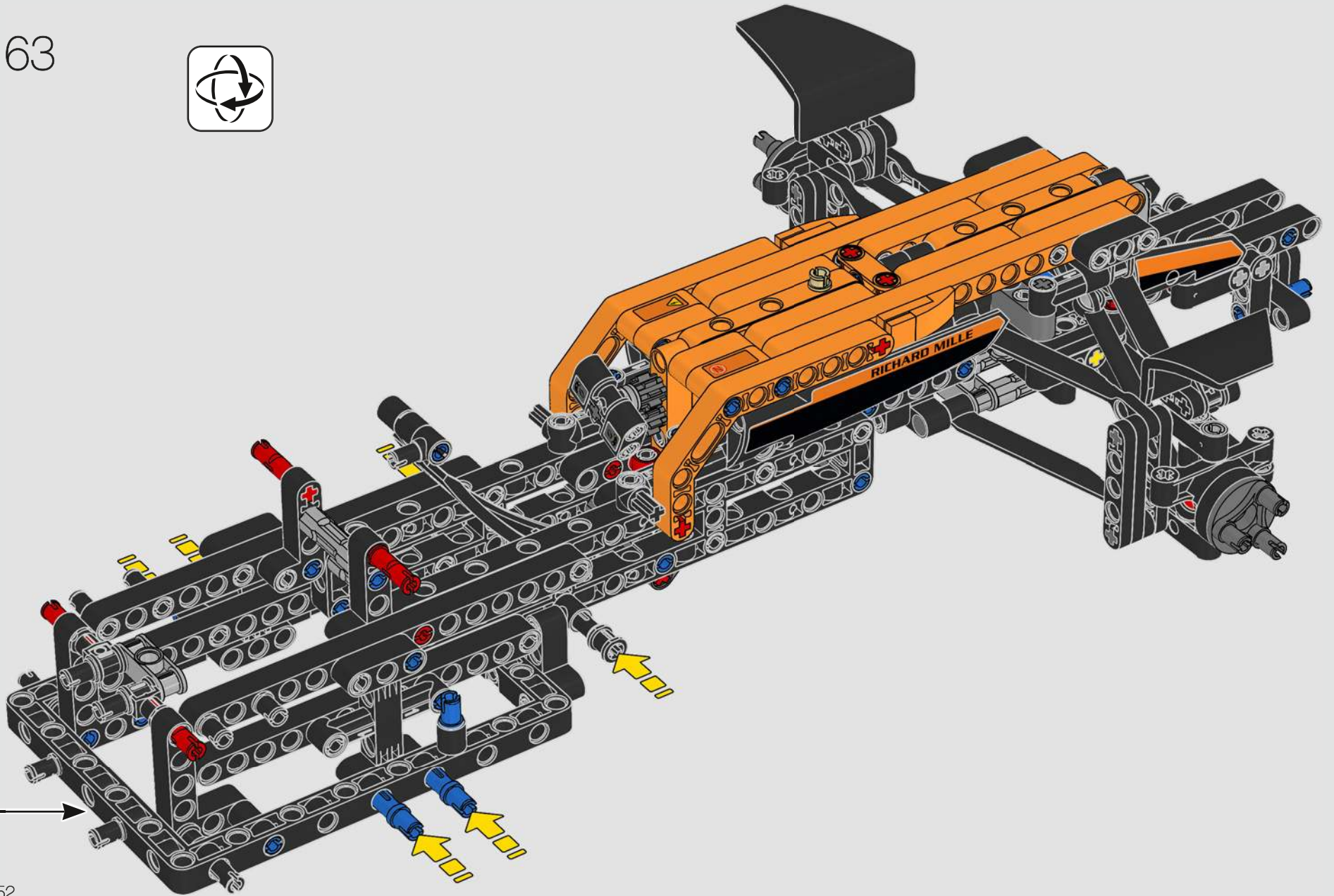

152

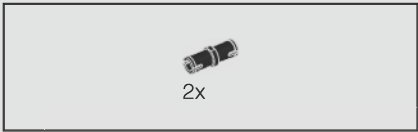

164

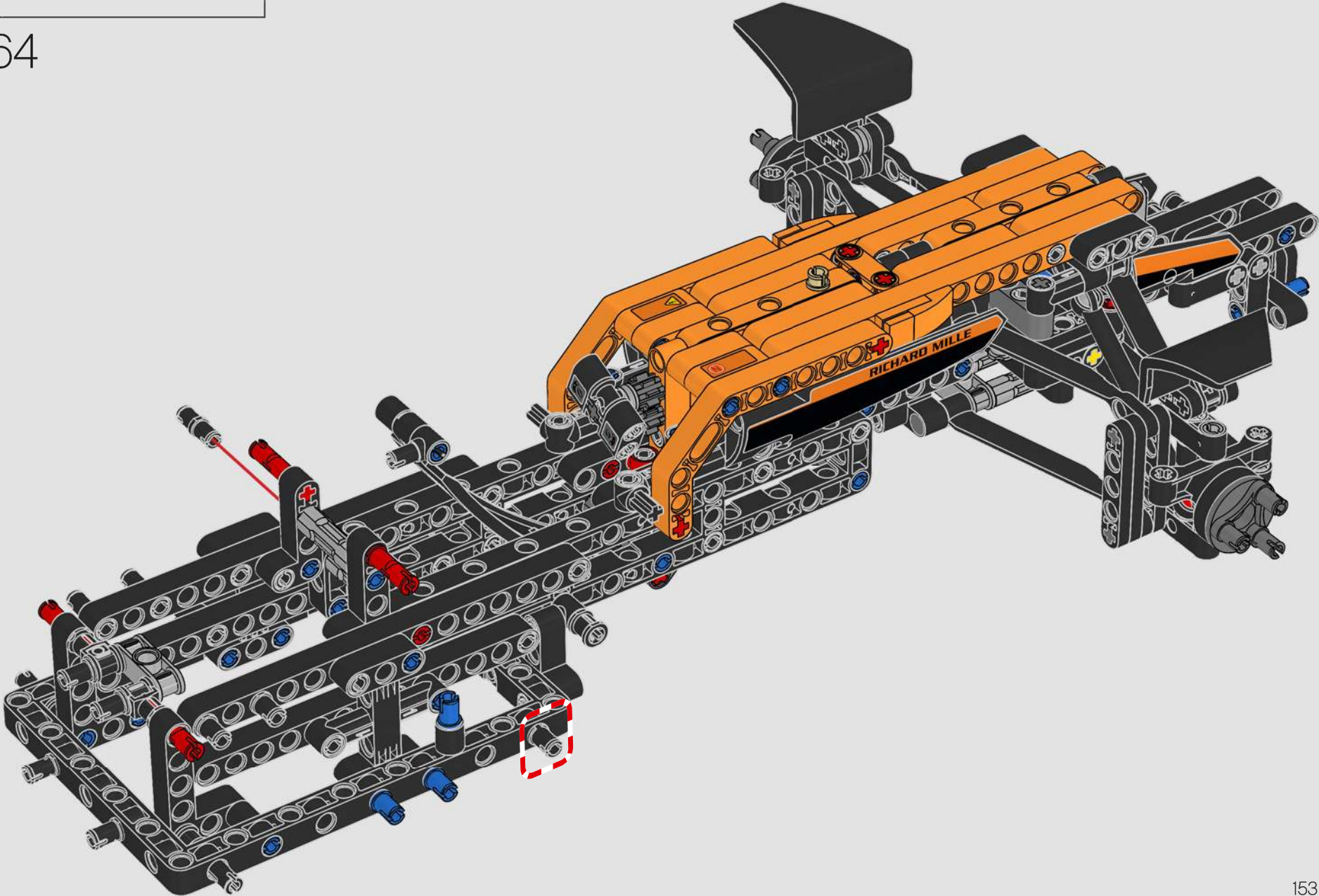

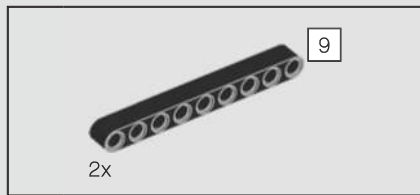

165

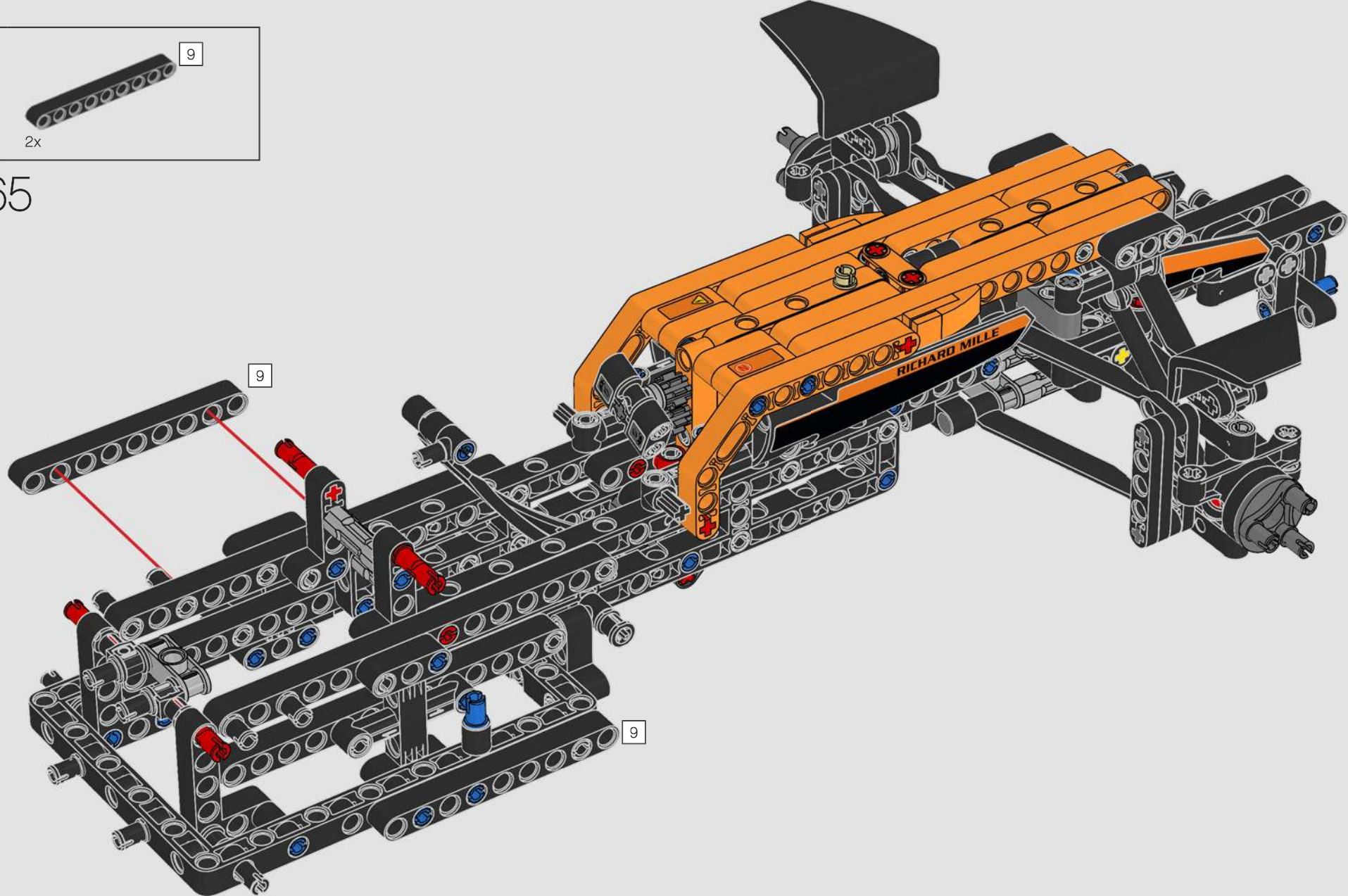

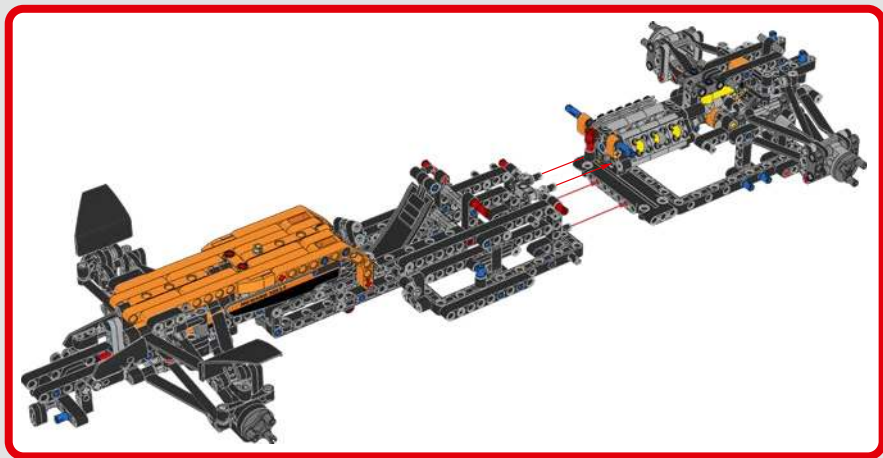

166

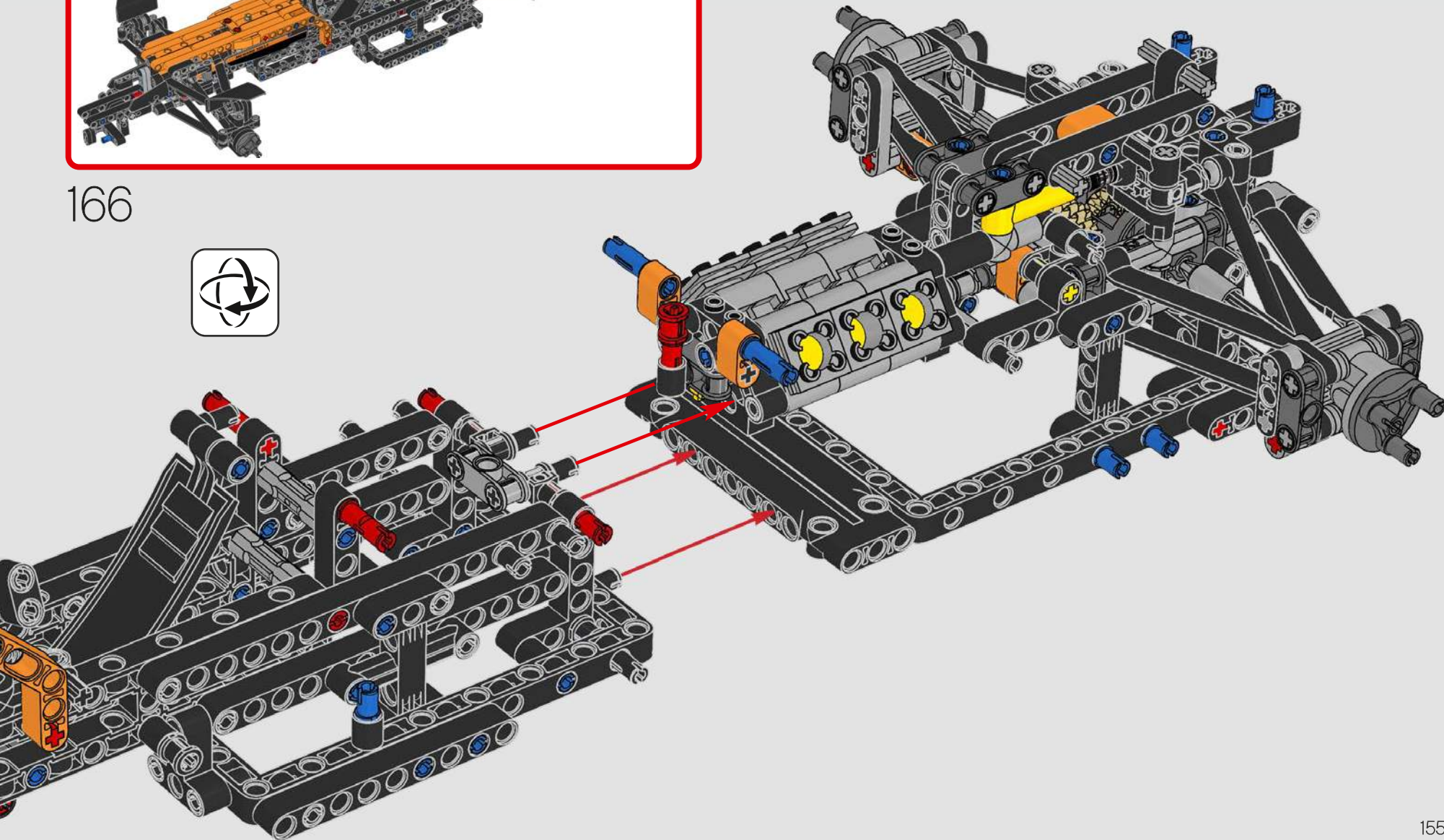



6x

167

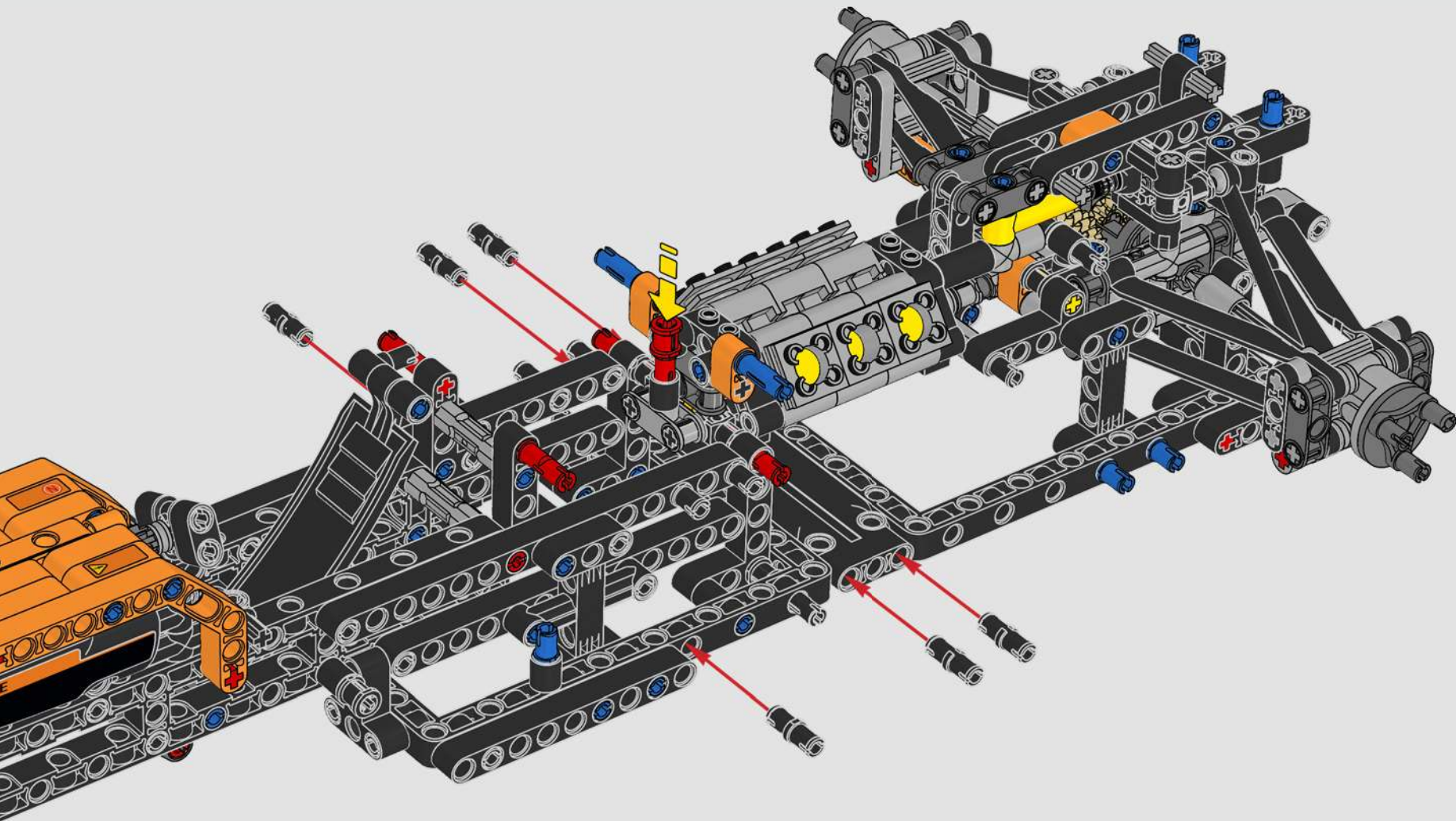

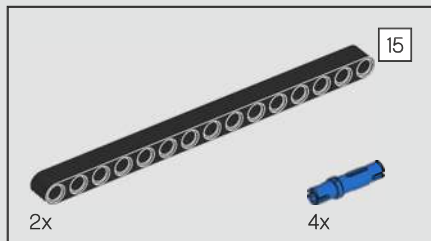

168

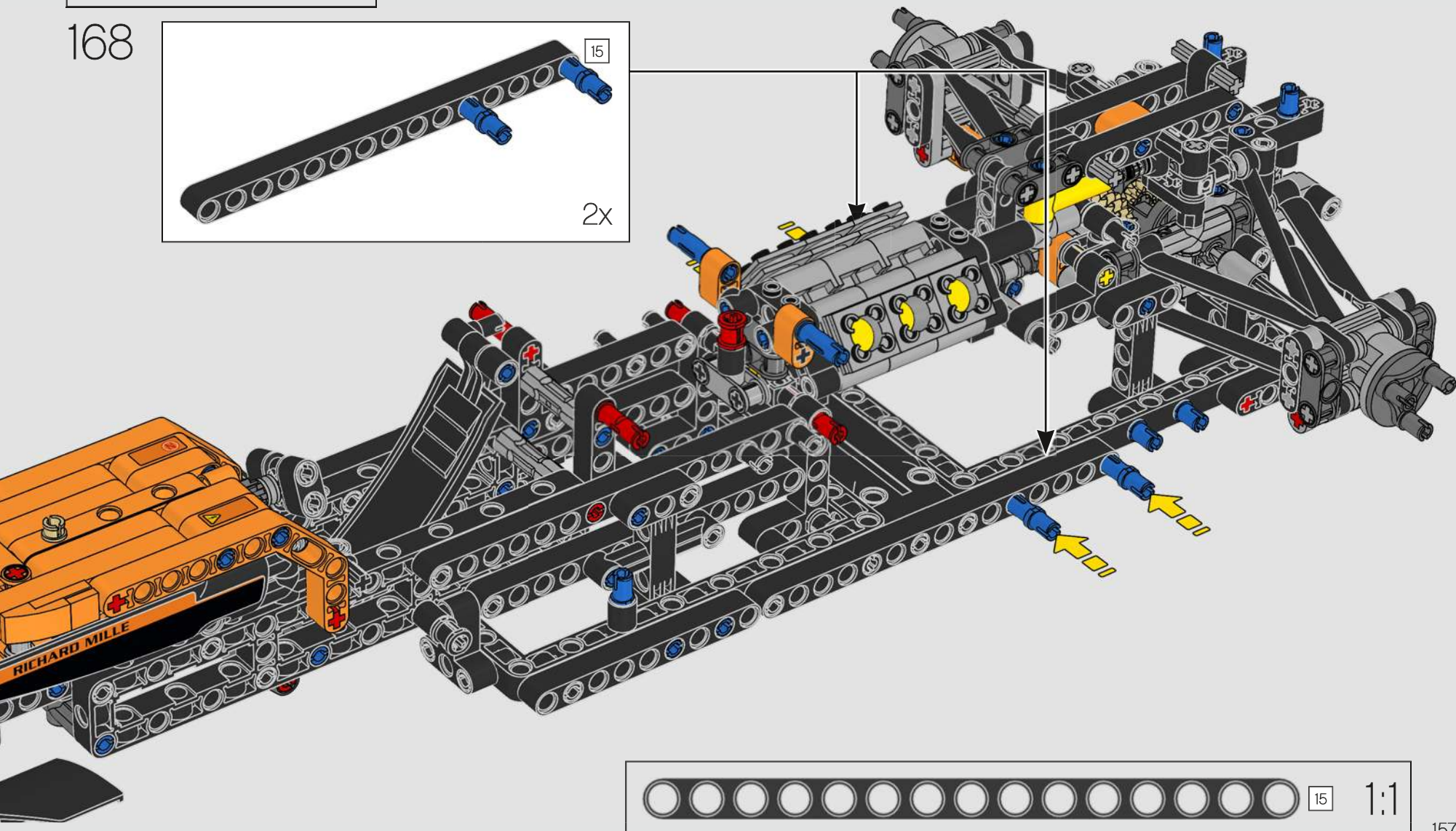
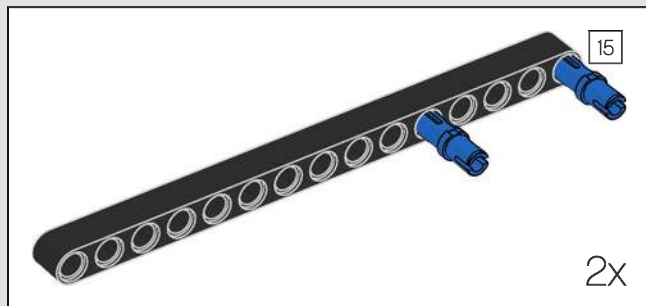

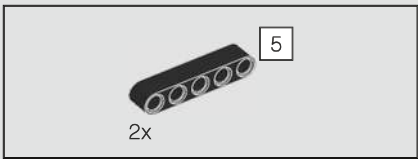

169

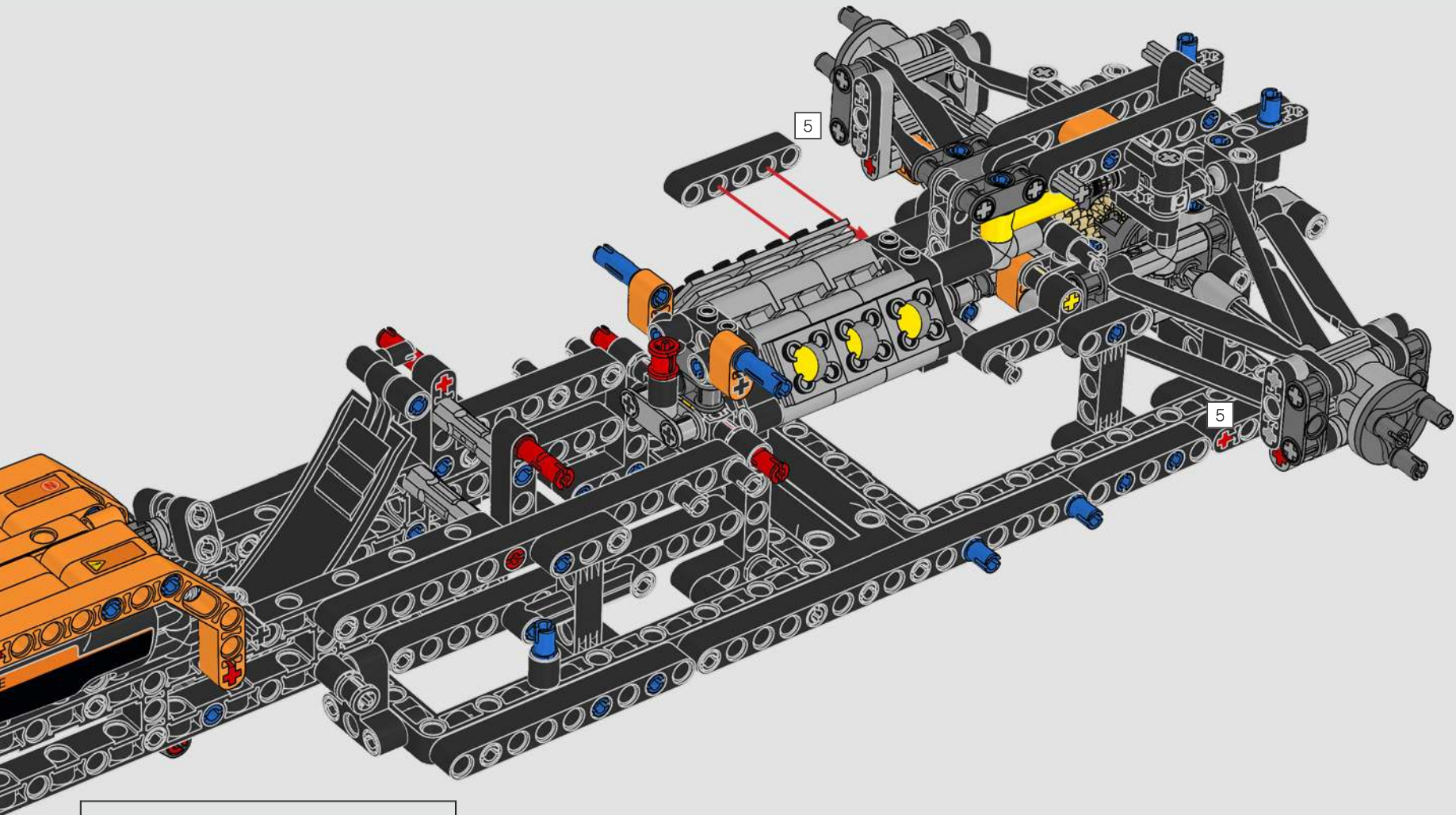



170

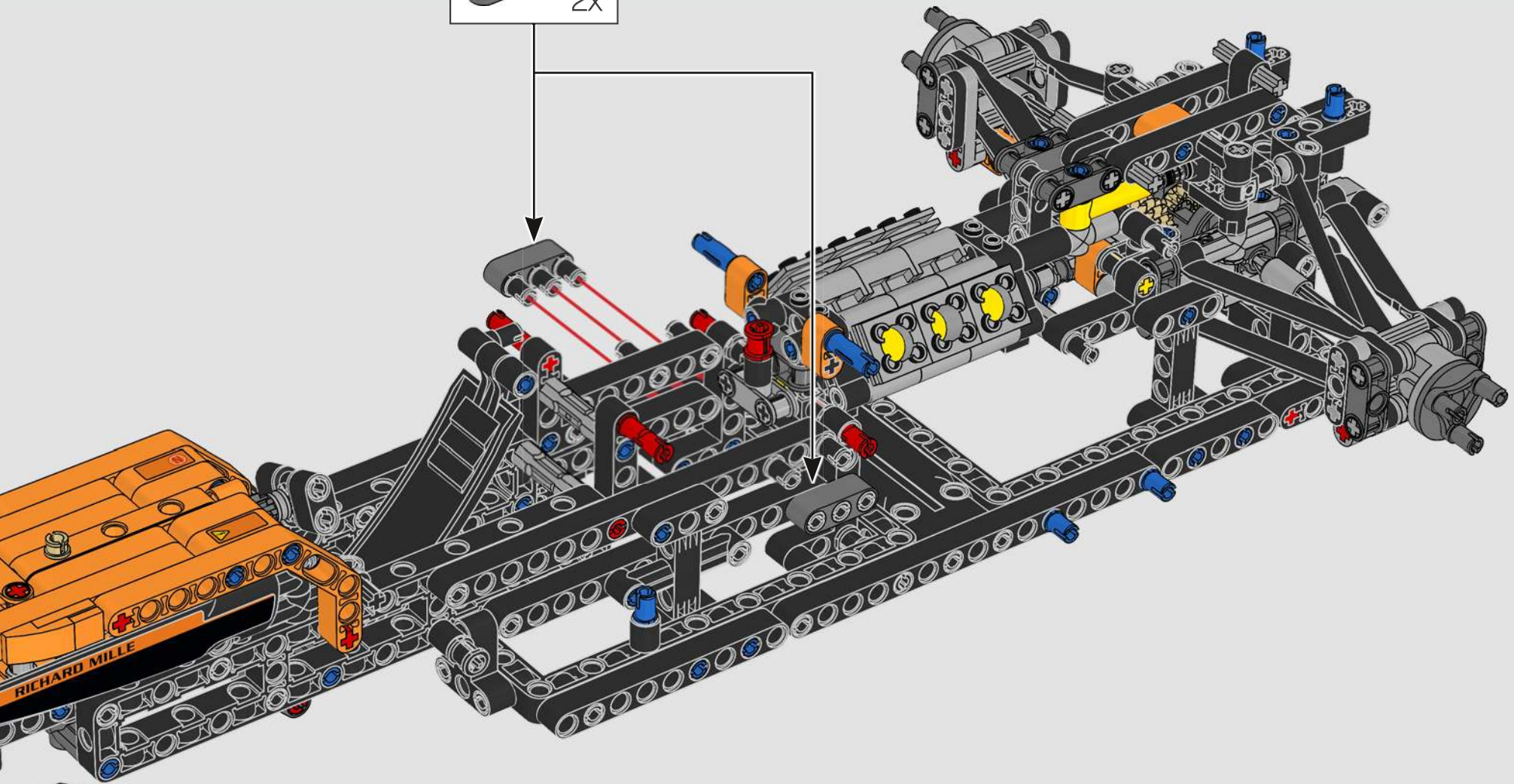
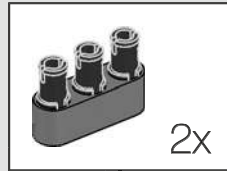



2x

171

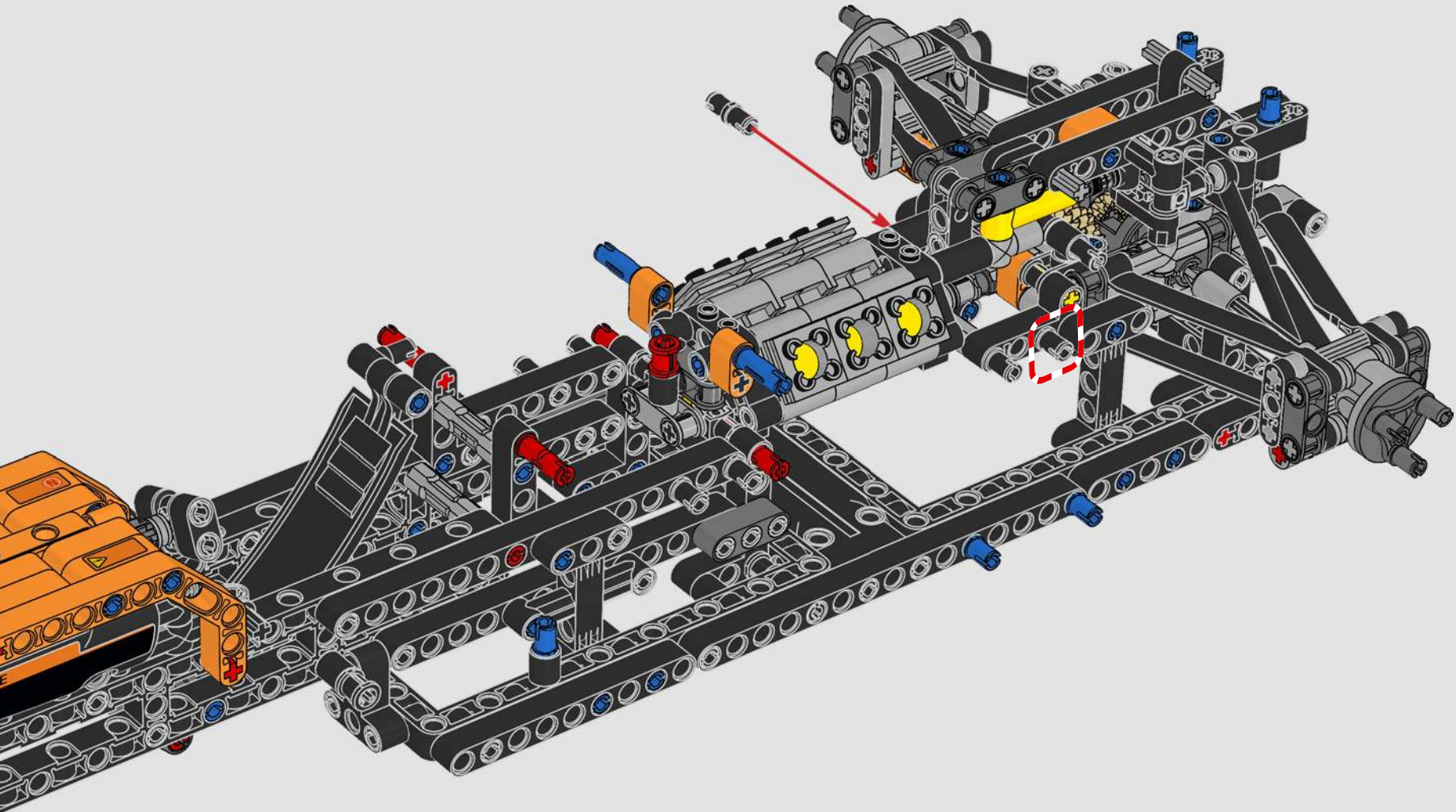

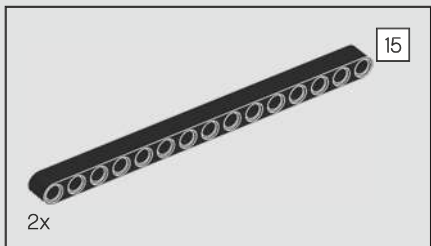

172

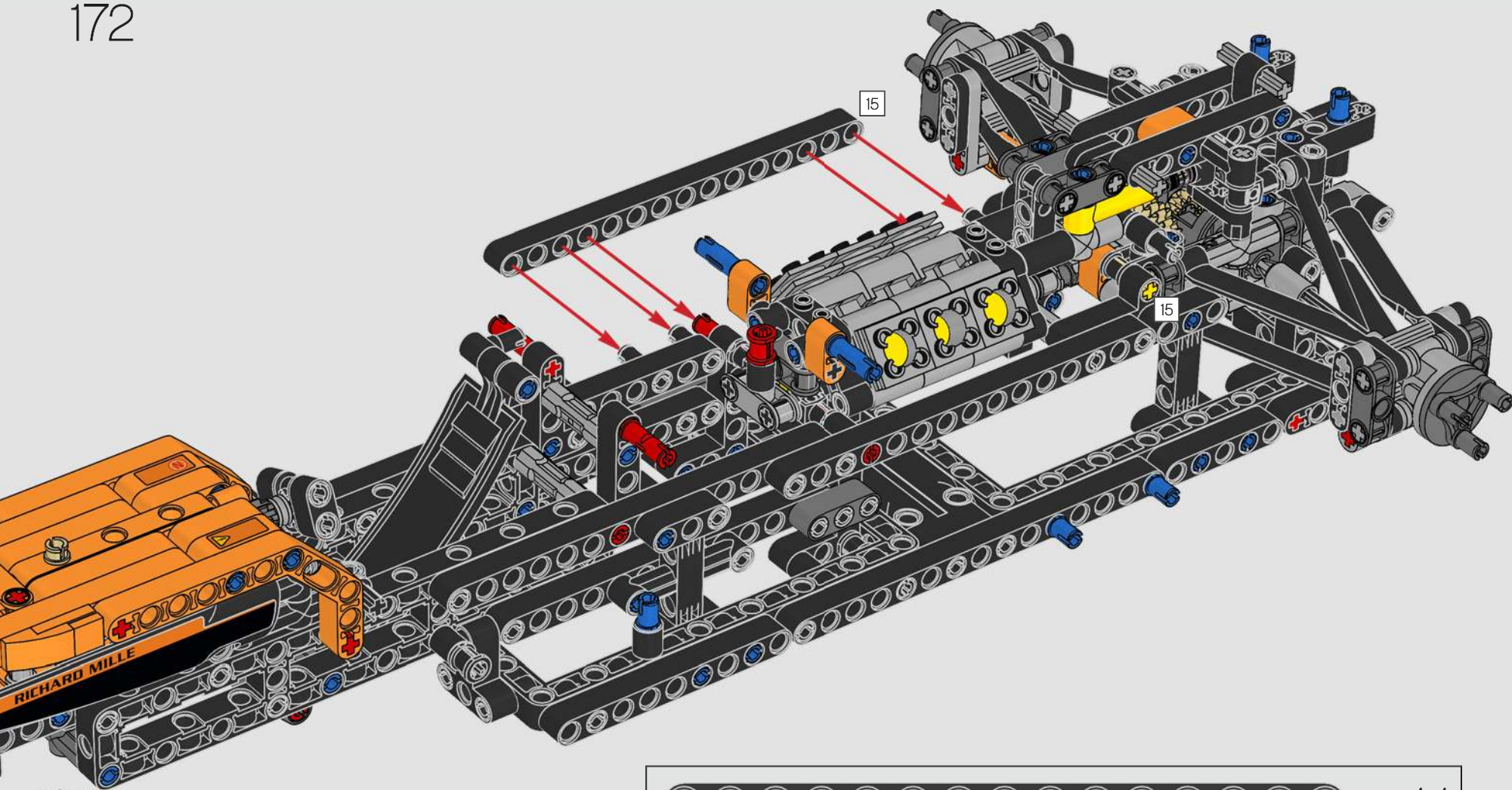

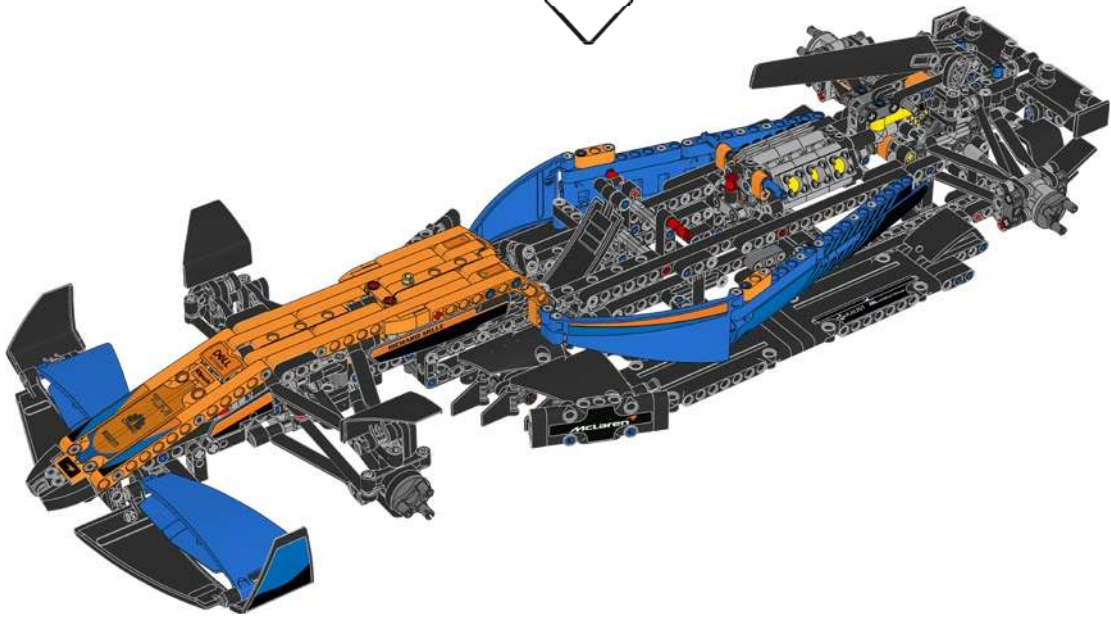
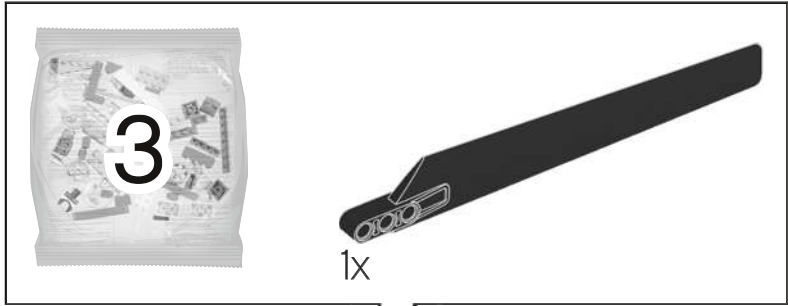

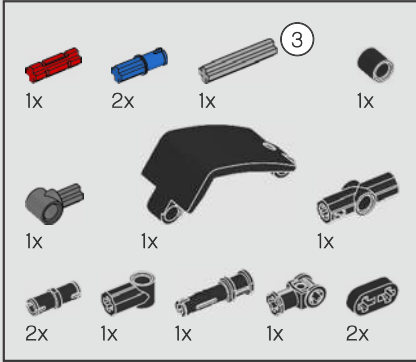
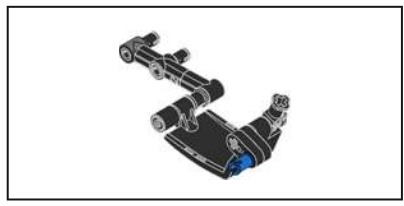

173

1

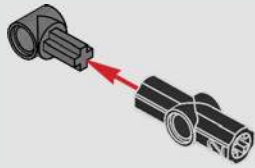

2



3

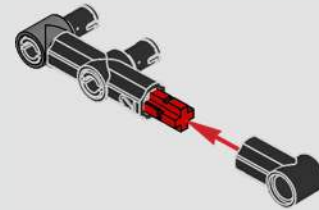

4

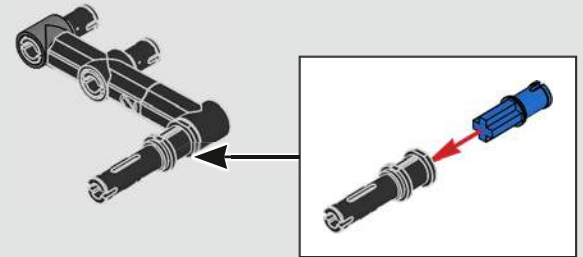

5

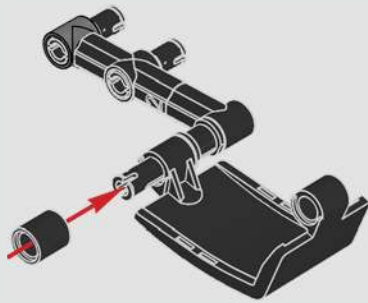

6

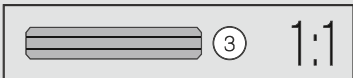
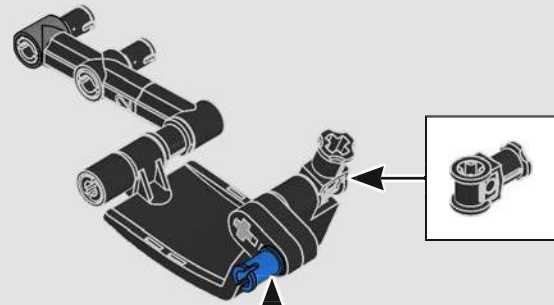

1:1

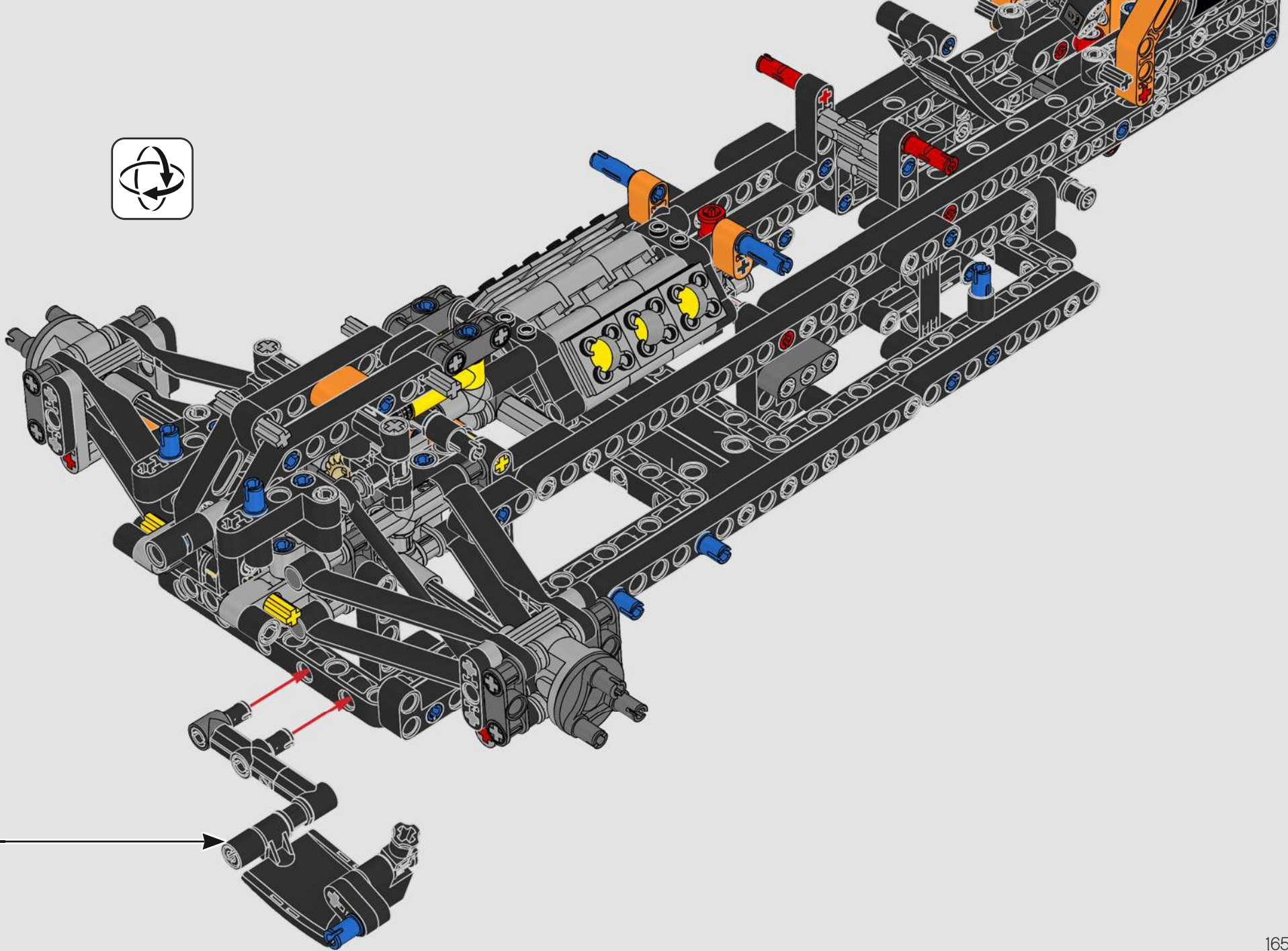

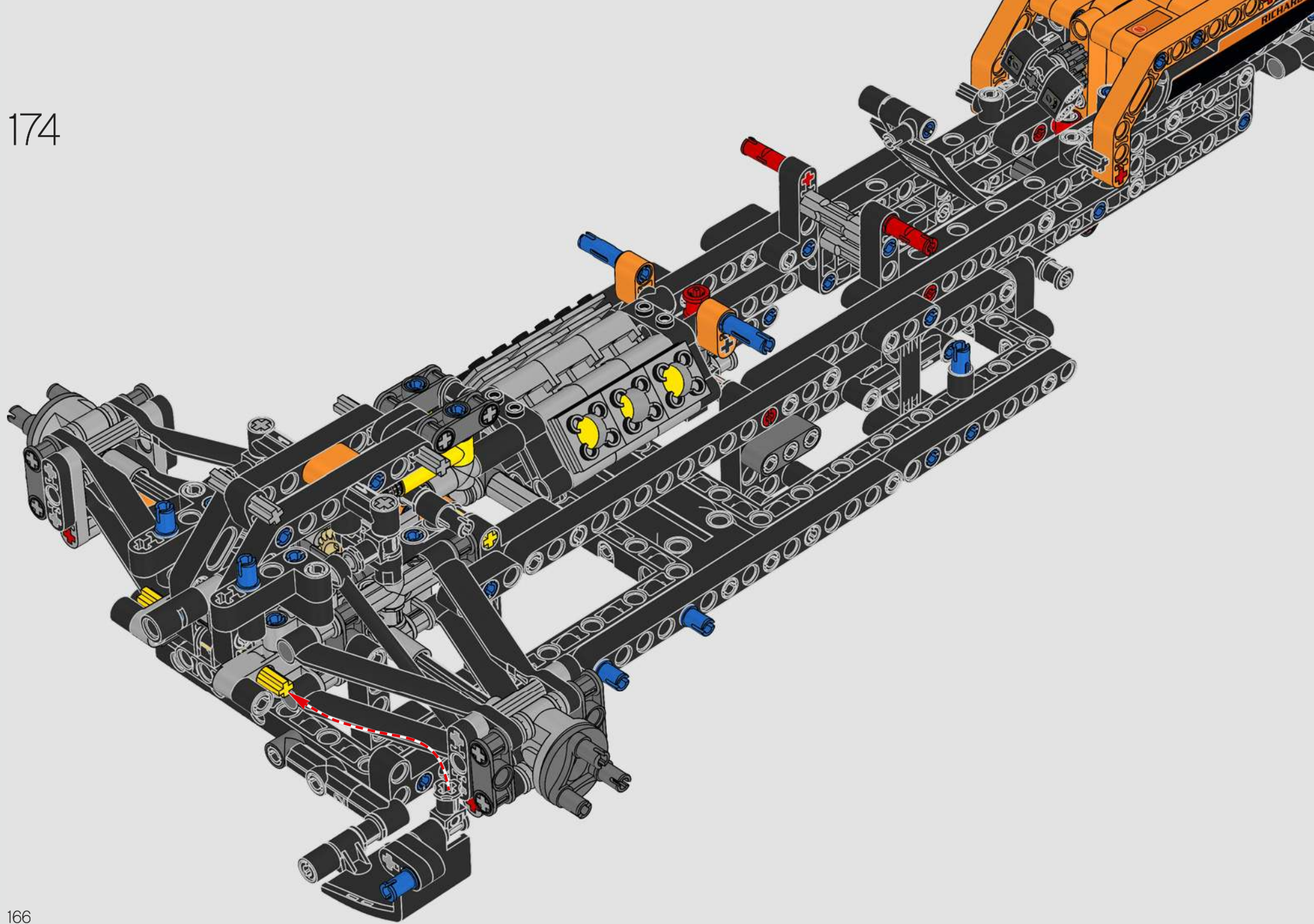

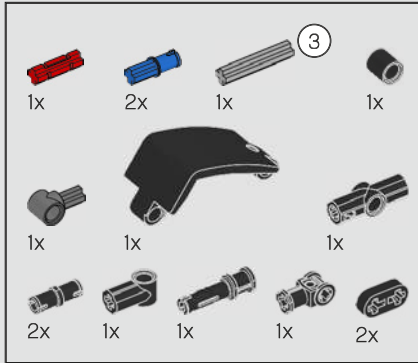
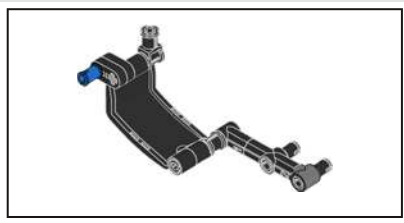

175

1

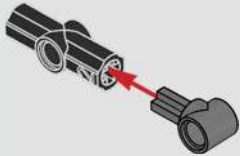

2



3

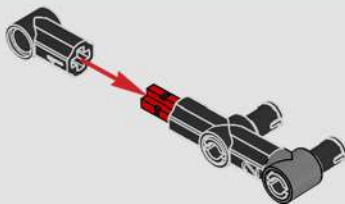

4

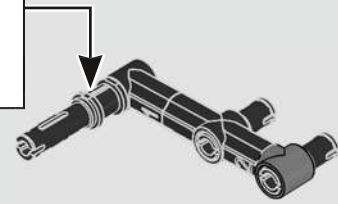
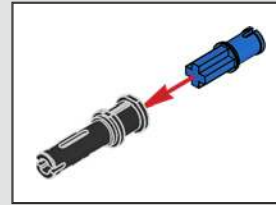

5

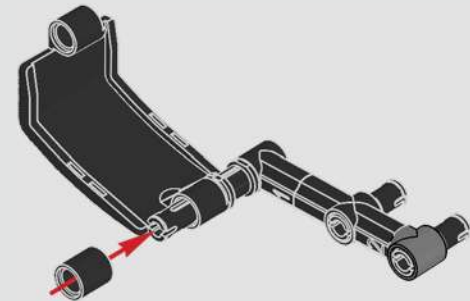

6

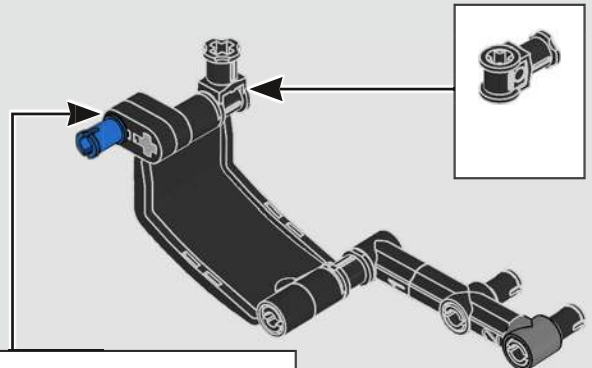

1

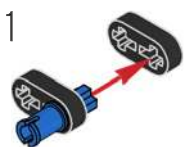

2

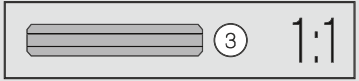
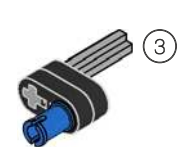

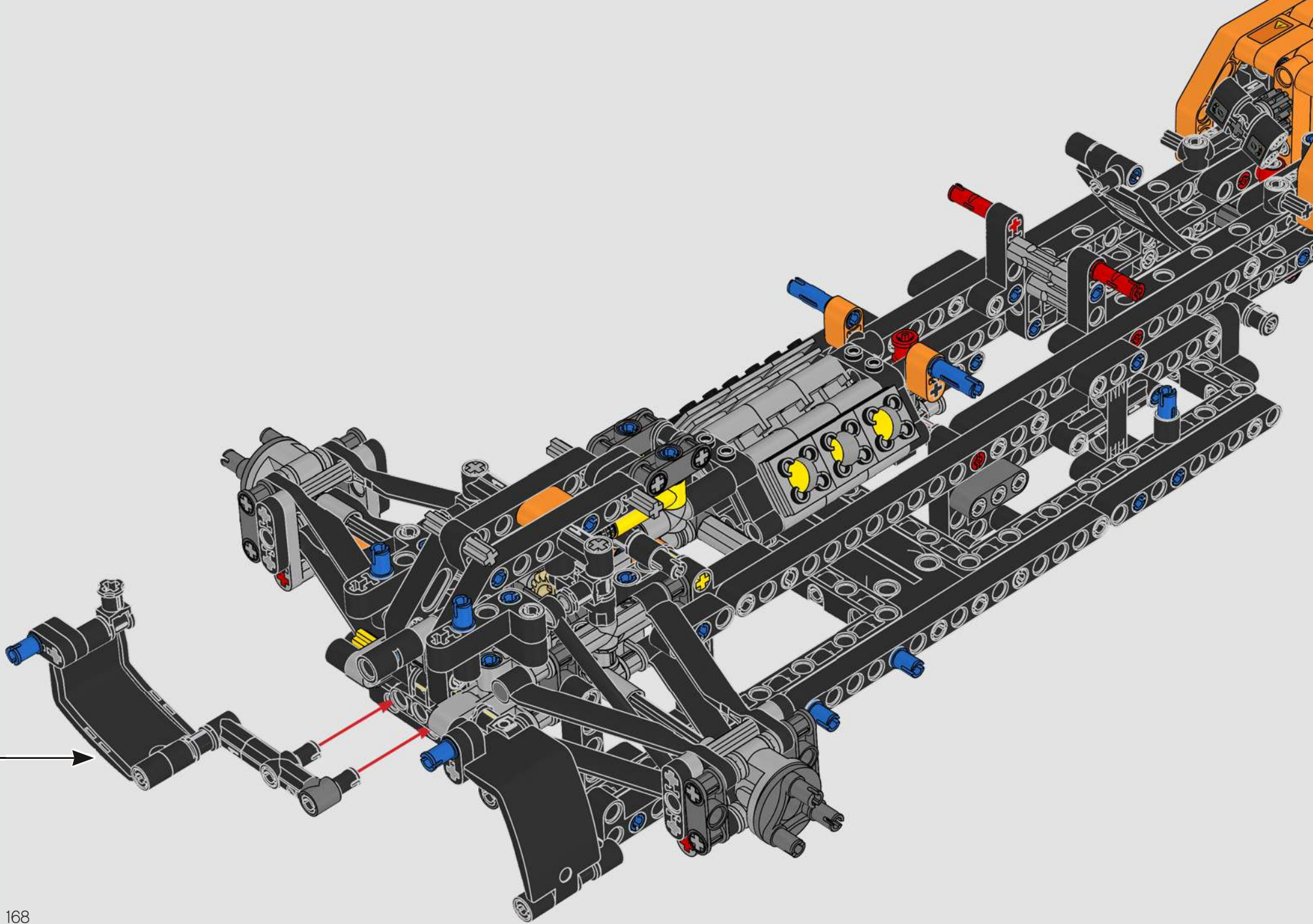

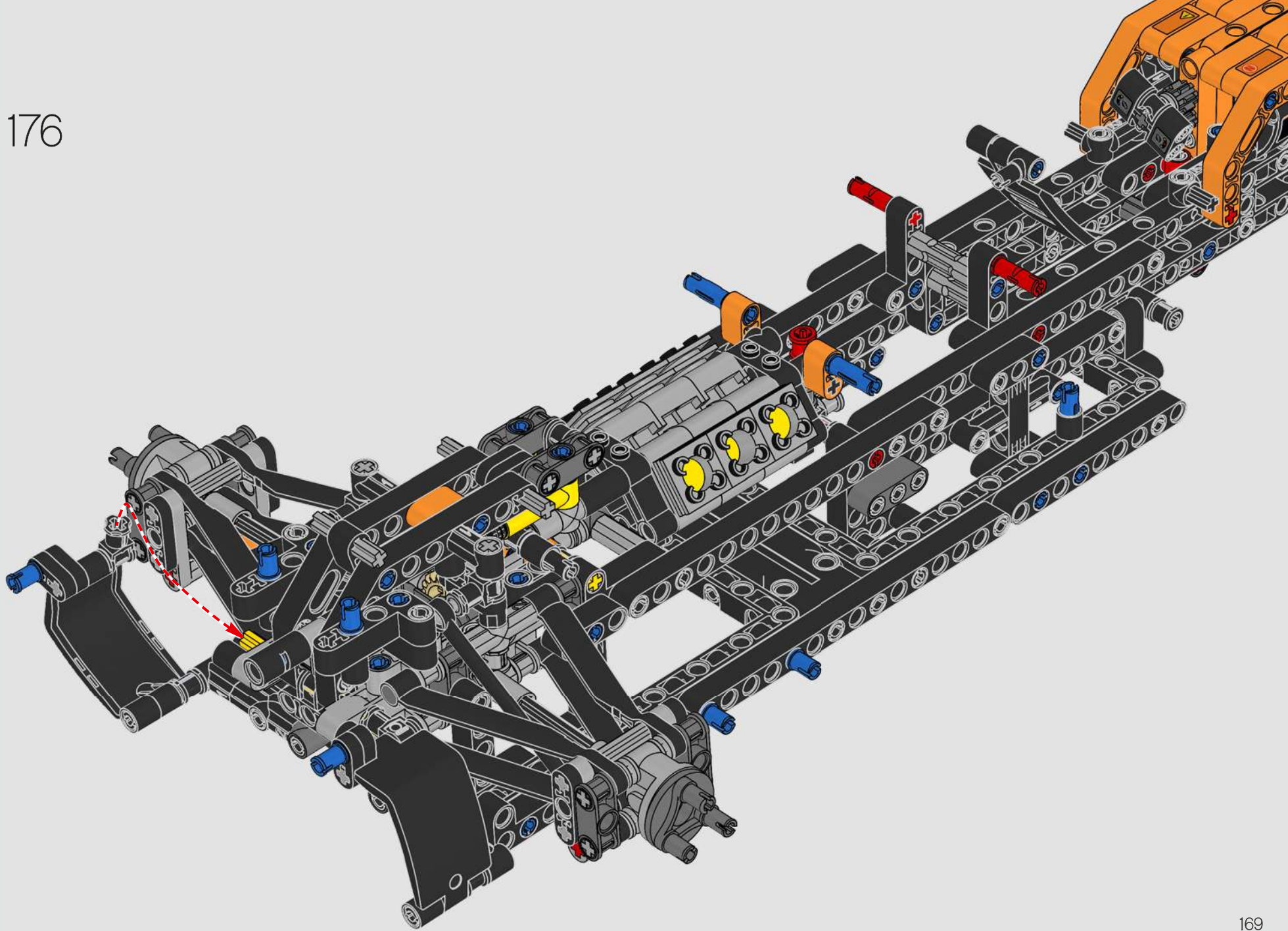

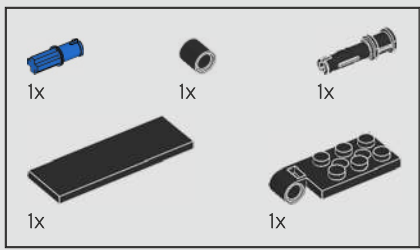

177

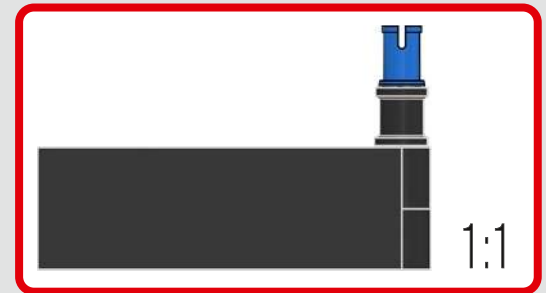
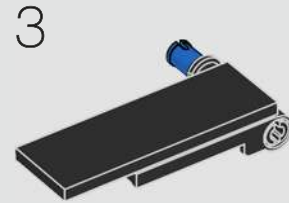
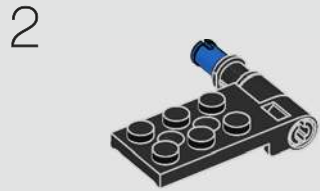
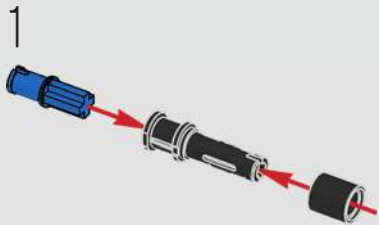

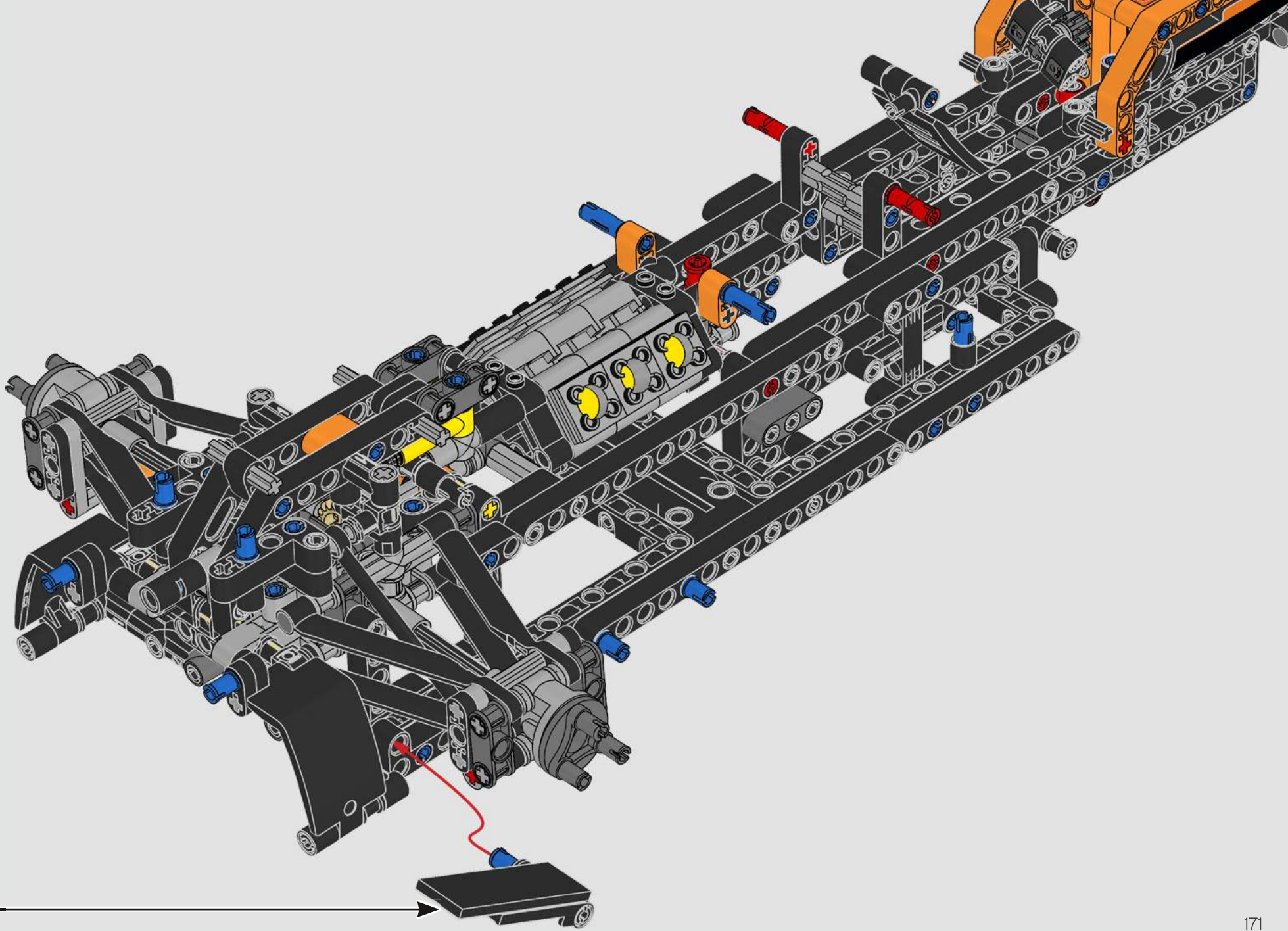

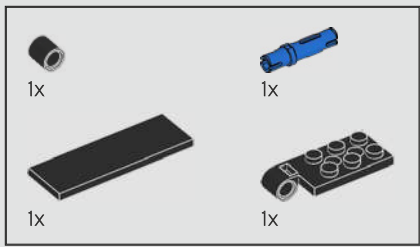

178

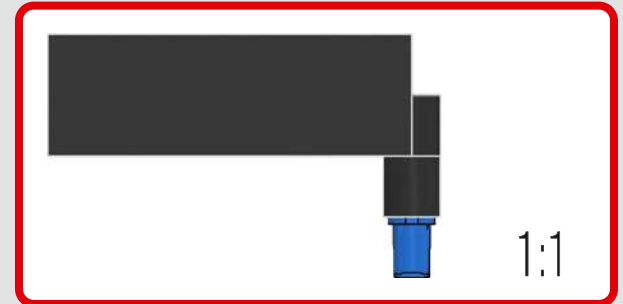
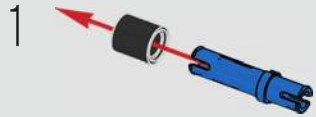

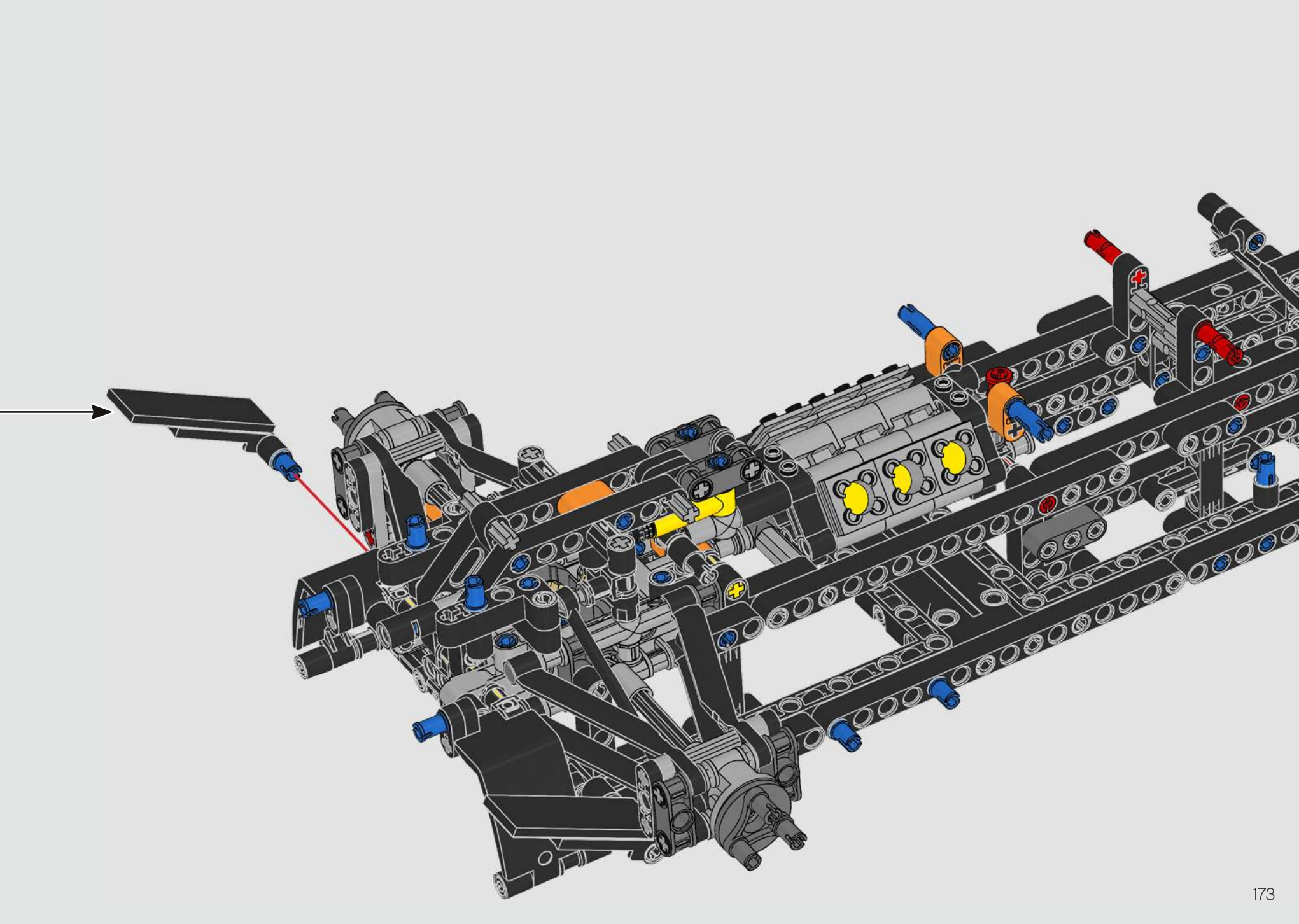

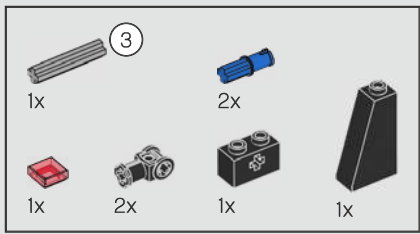

179

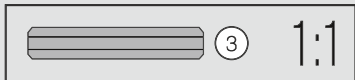
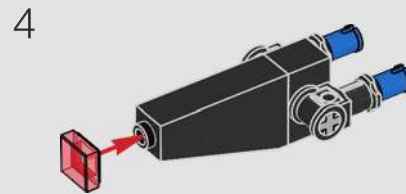
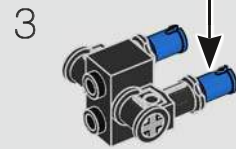
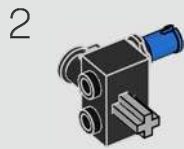
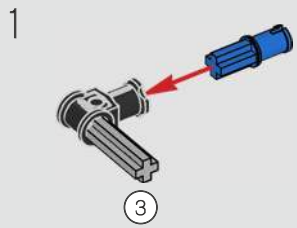

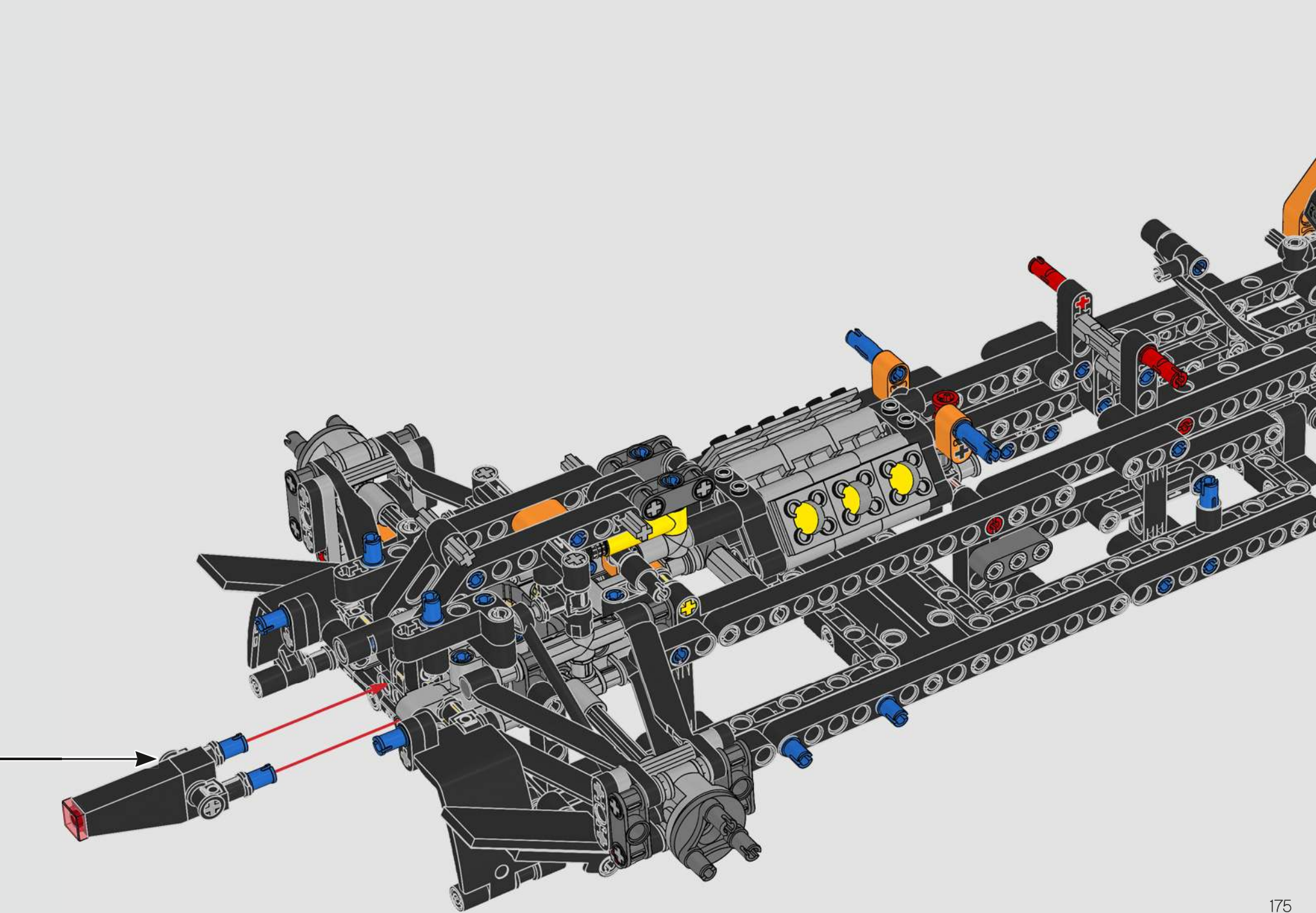

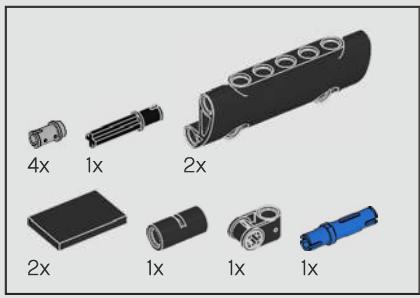

180

1

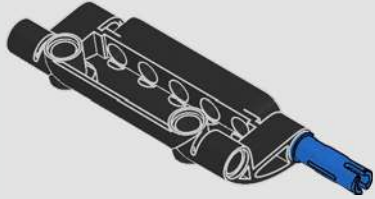

2

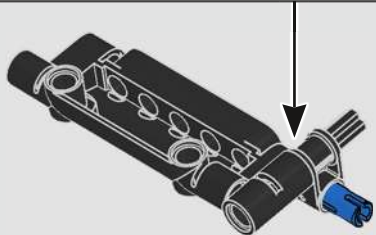
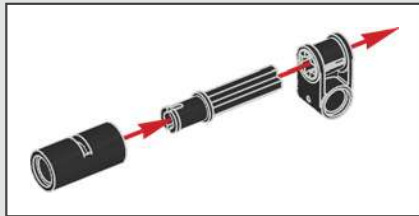

3

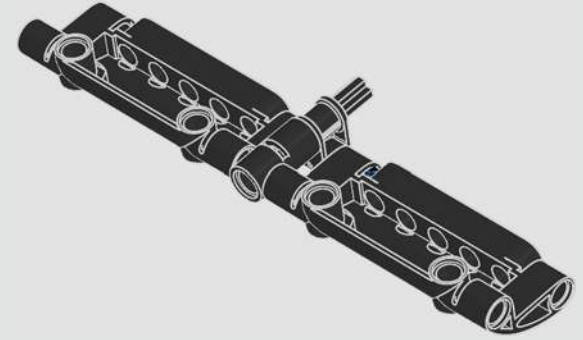

4

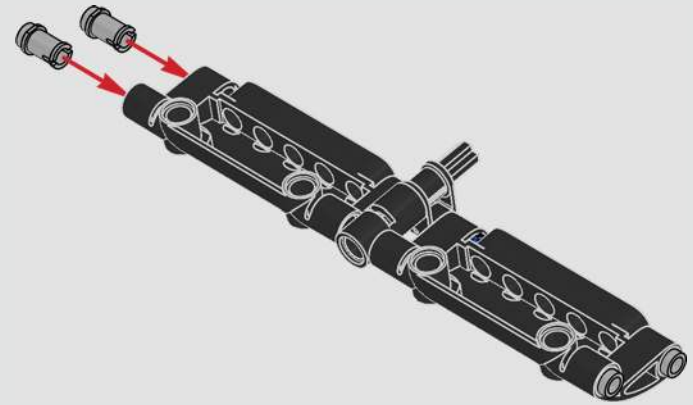

5

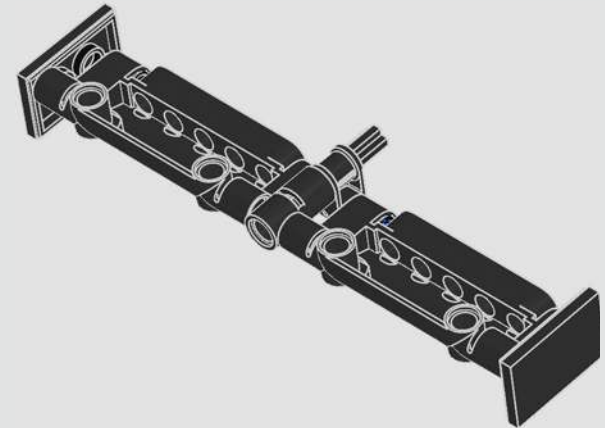

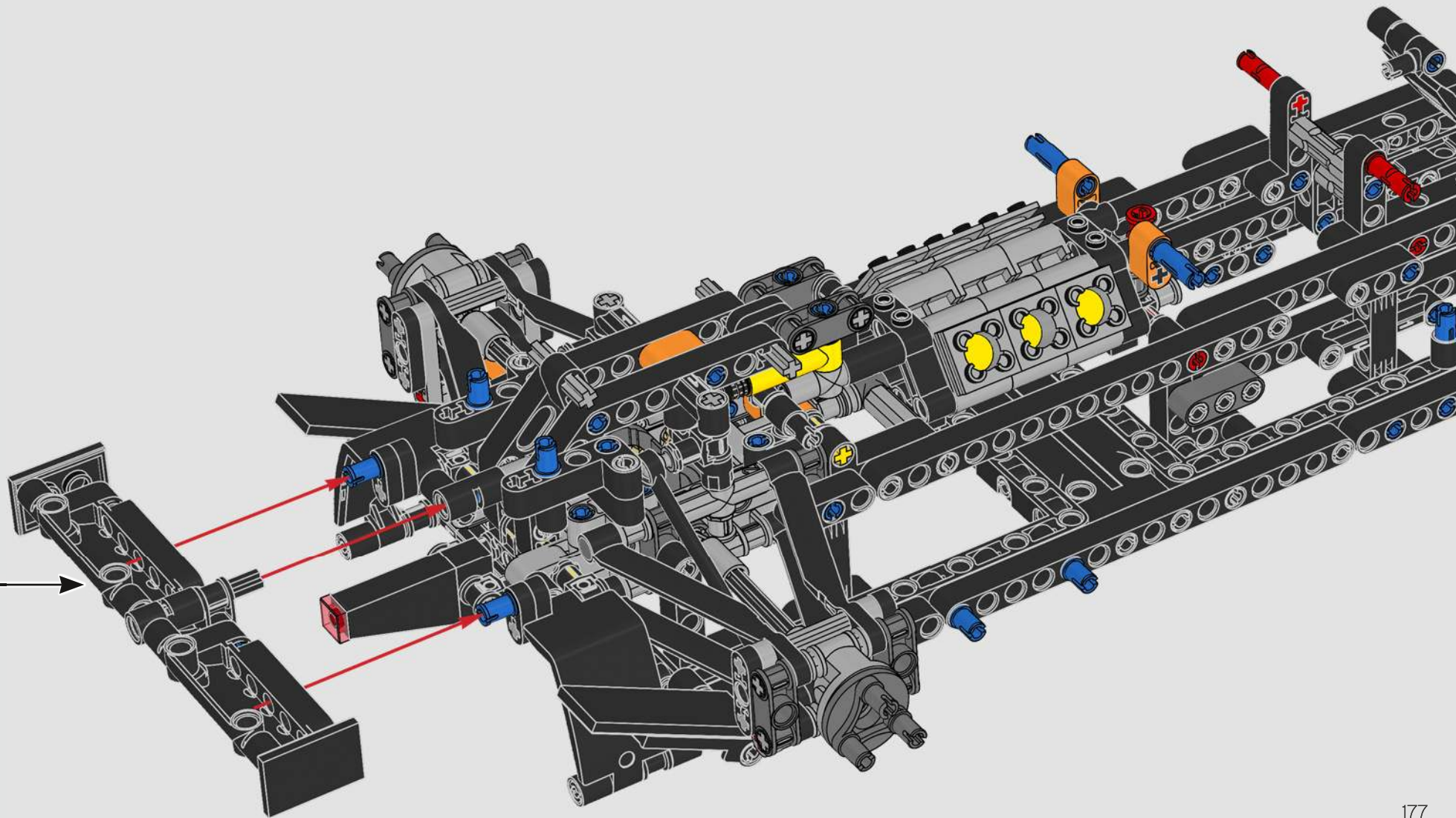



2x

181

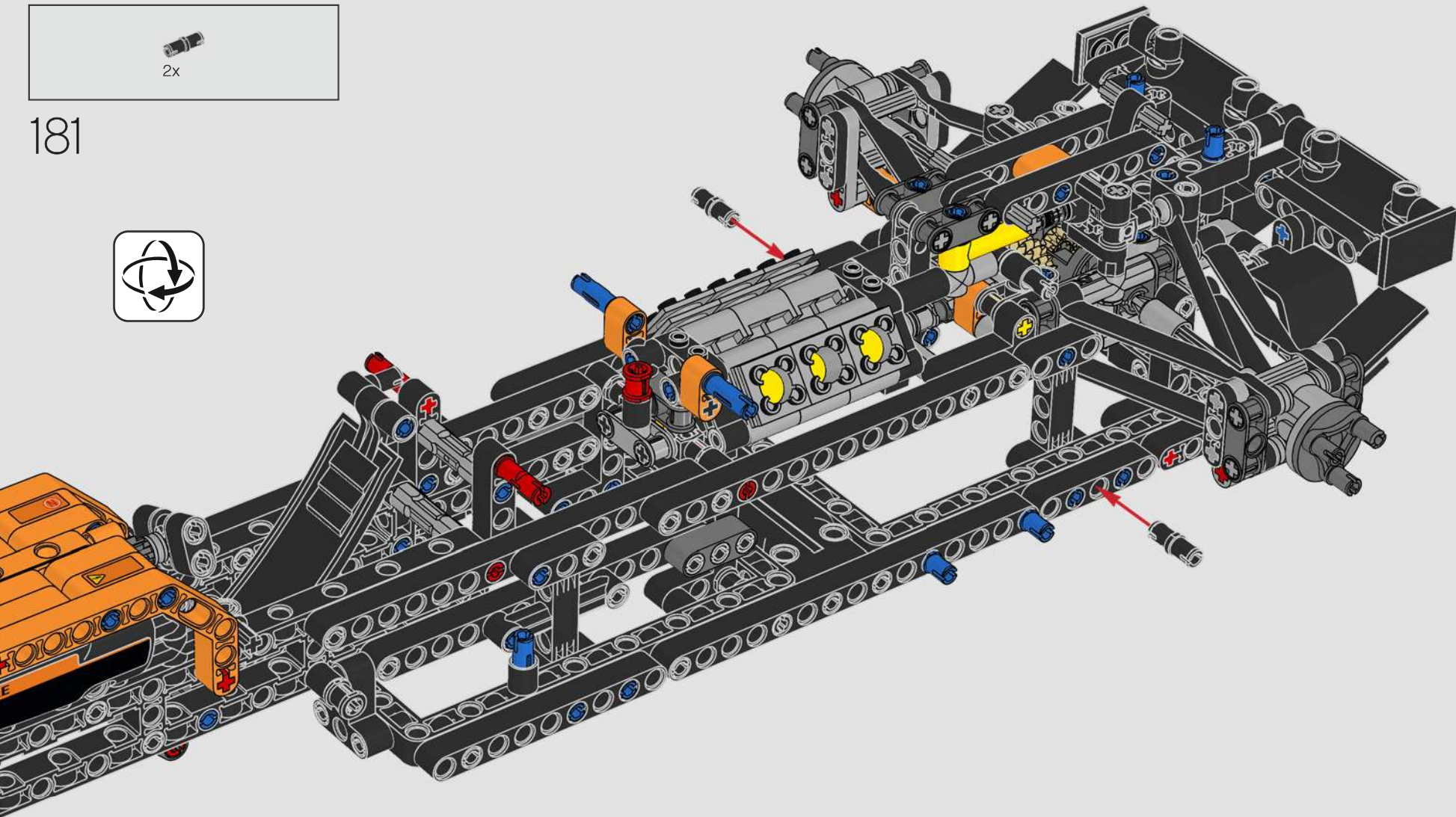

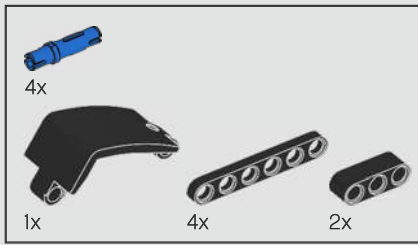

182

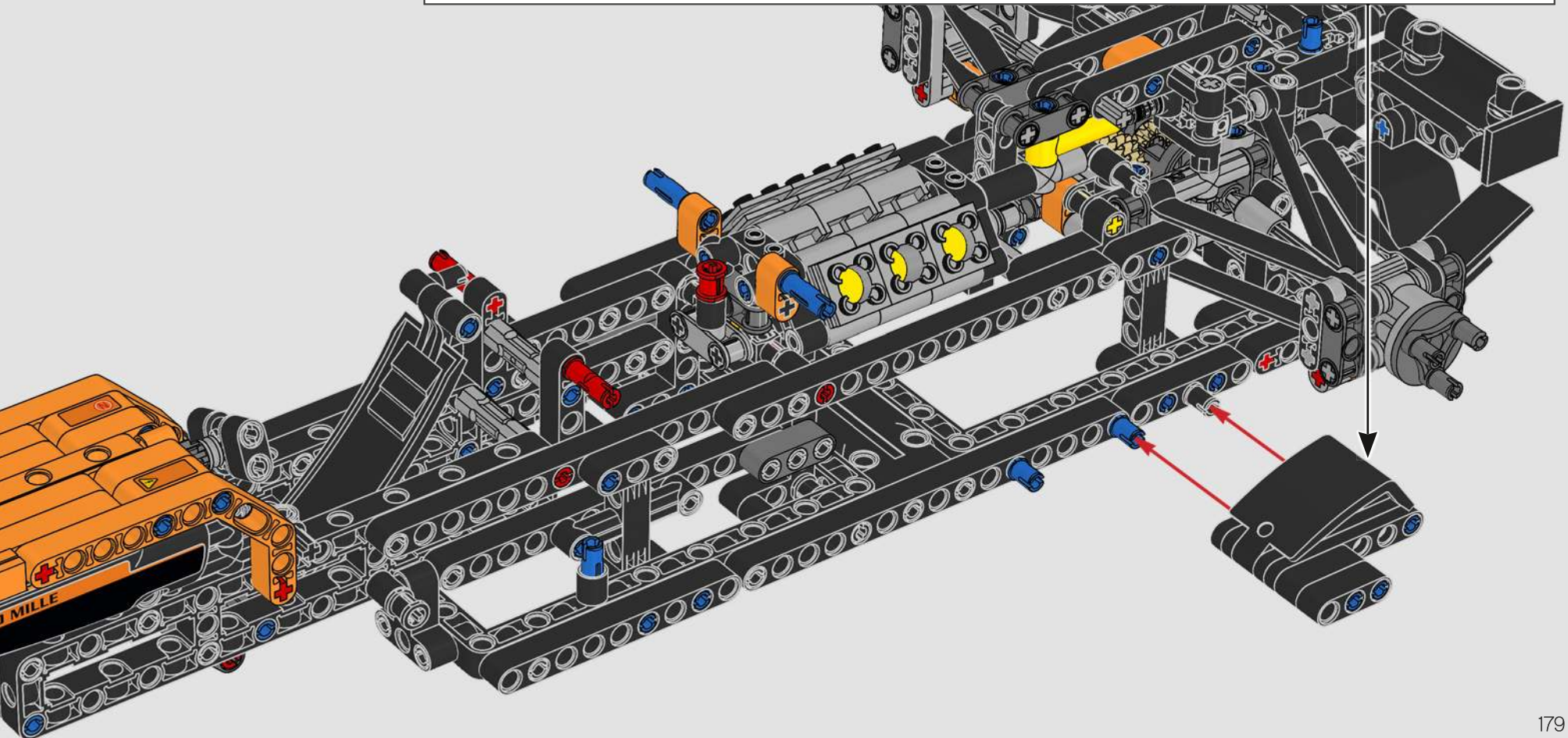
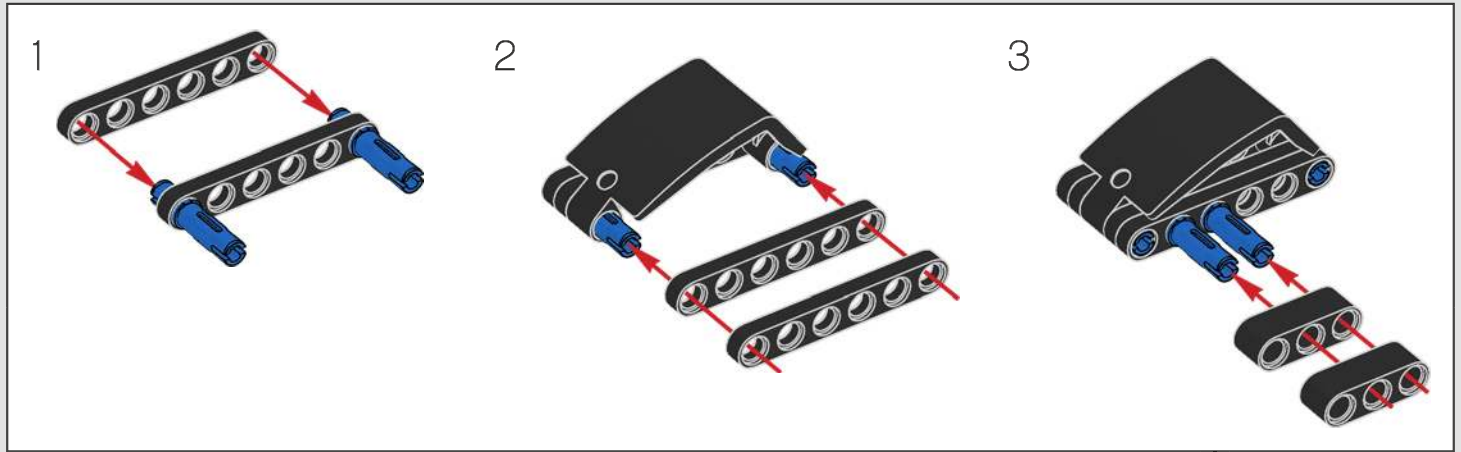

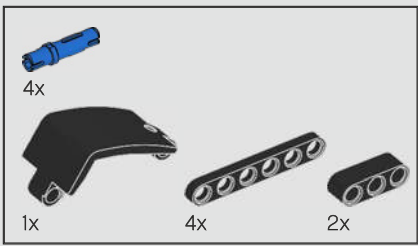

183

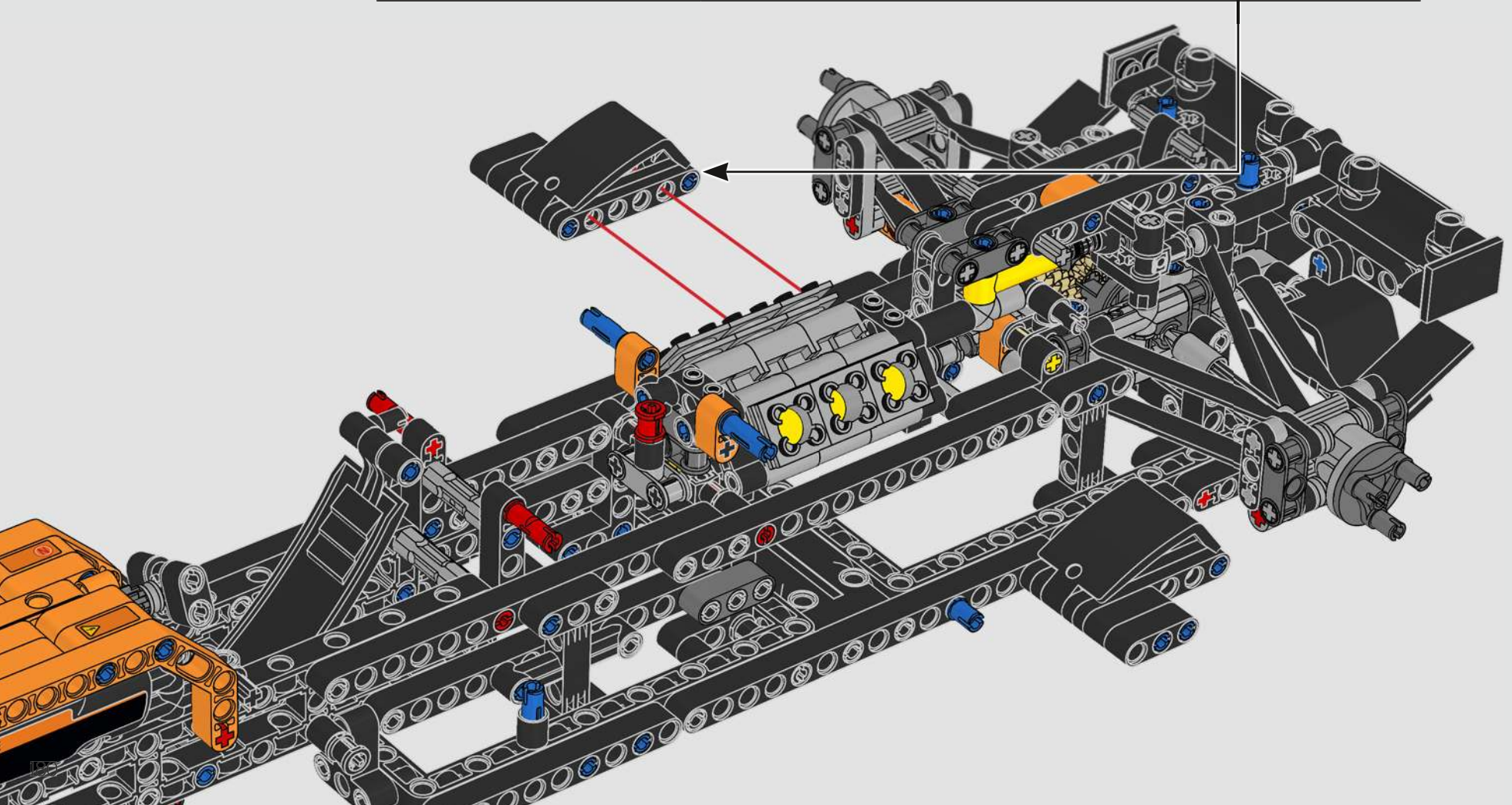
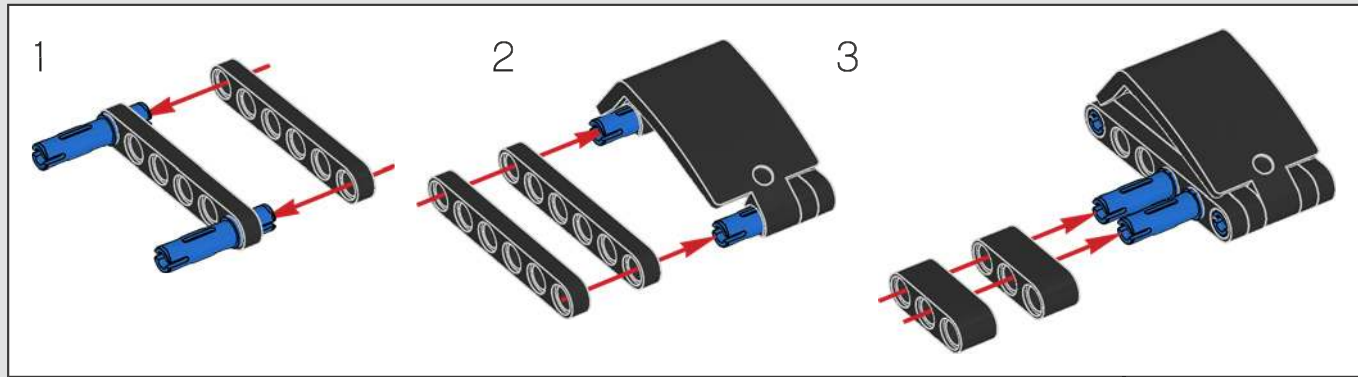

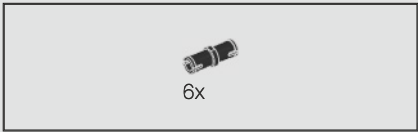

184

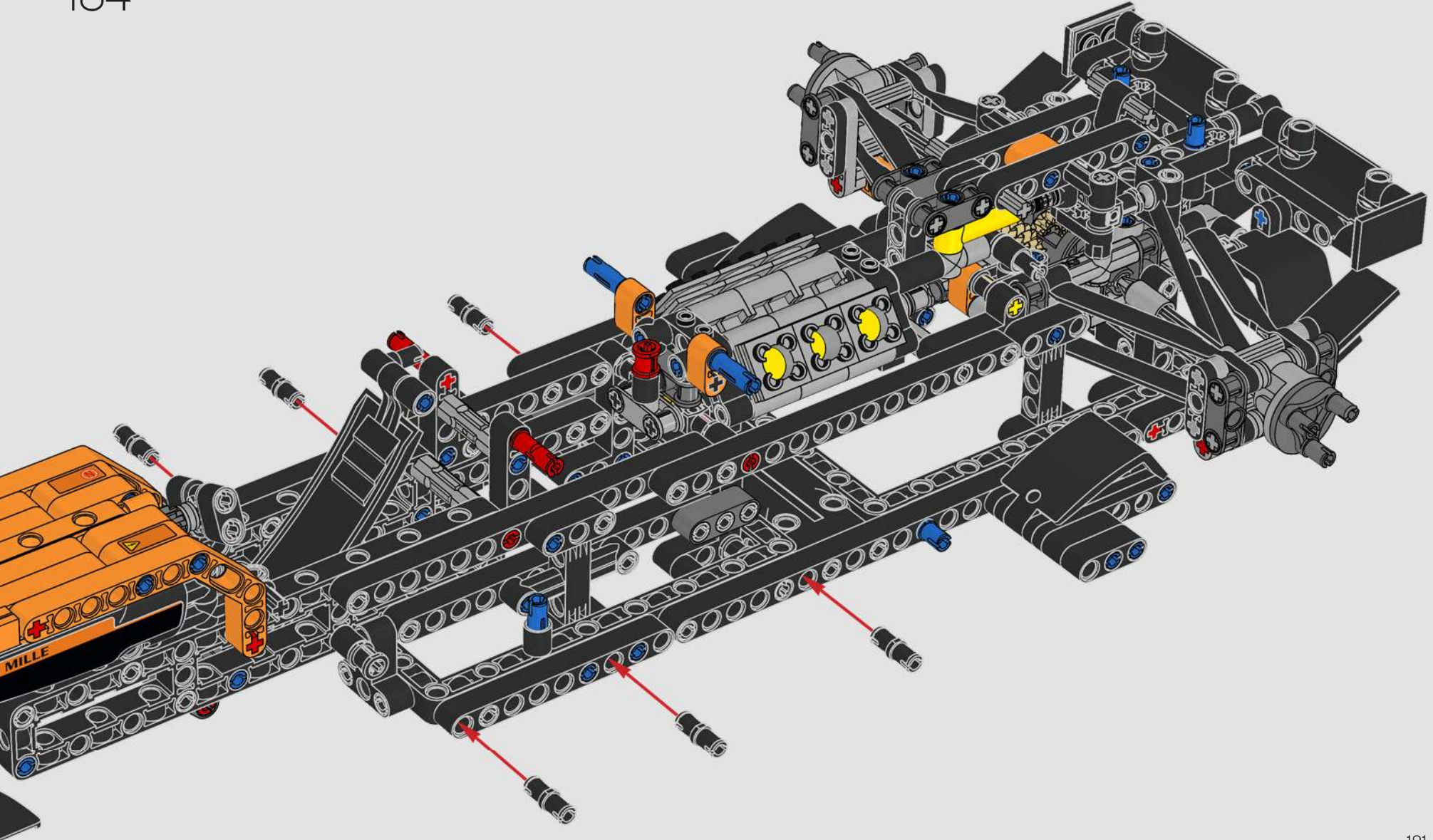

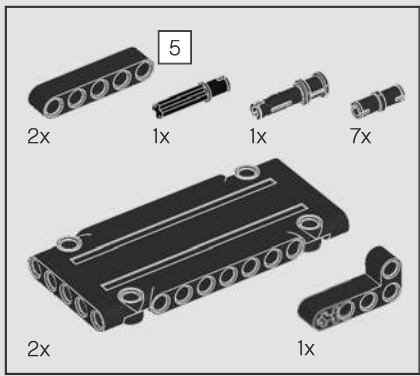

185

1

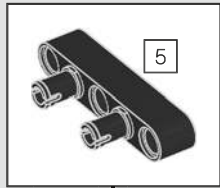
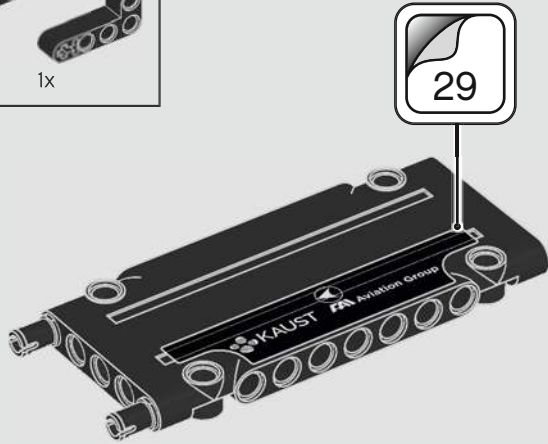

2

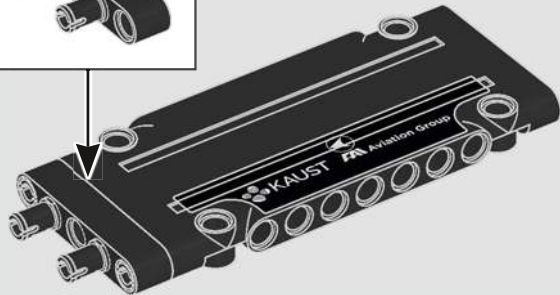

182

3

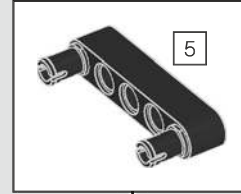

4

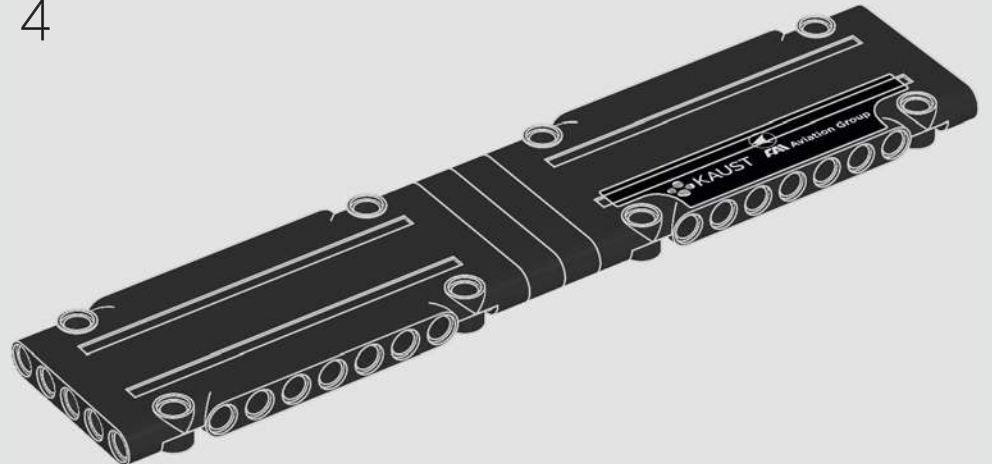

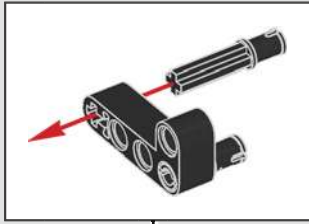

5

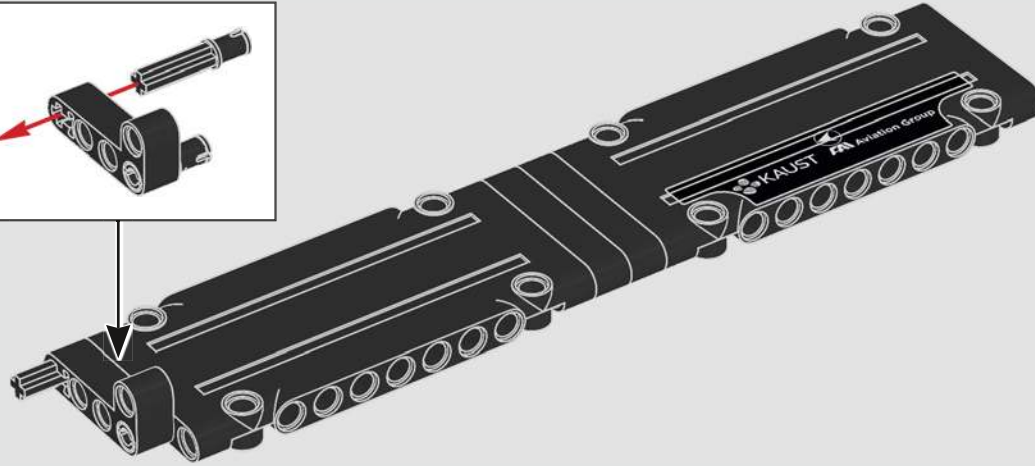

6

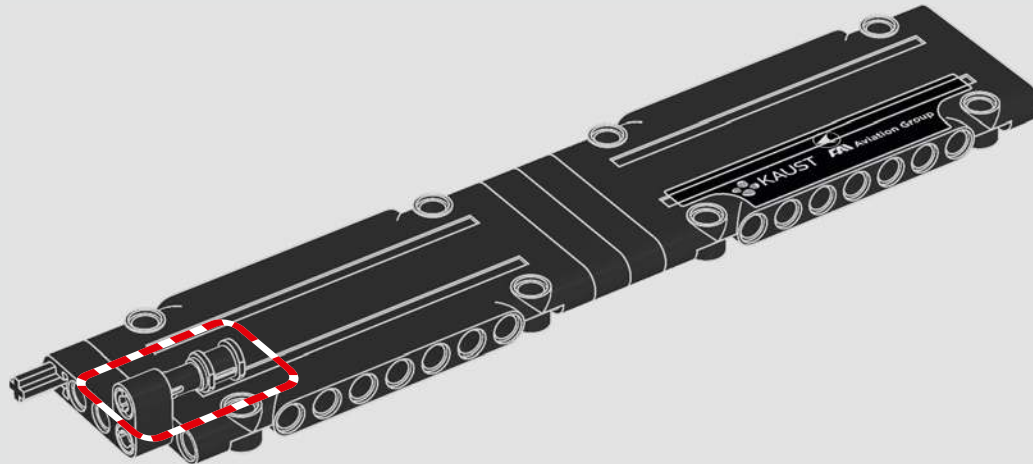

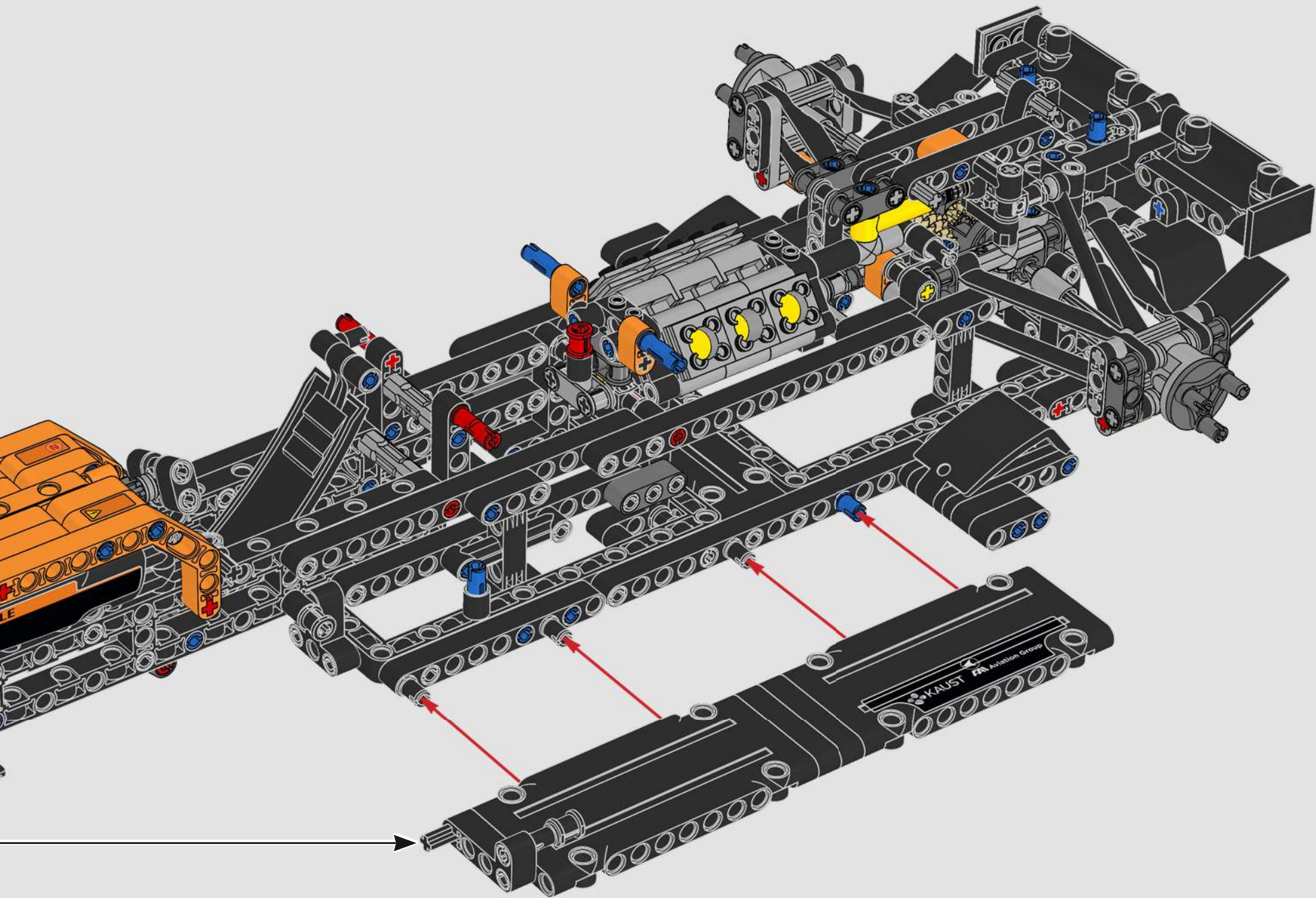

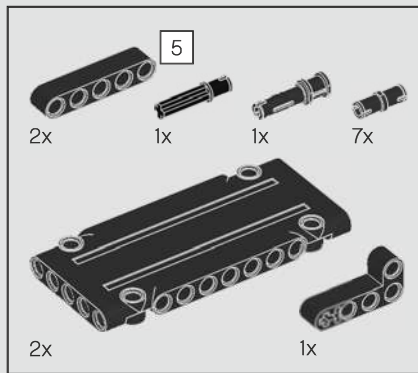

186

1

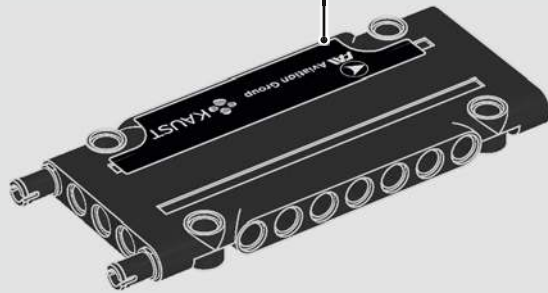

2

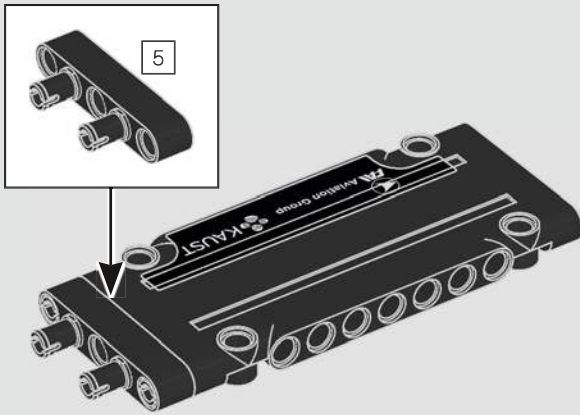

3

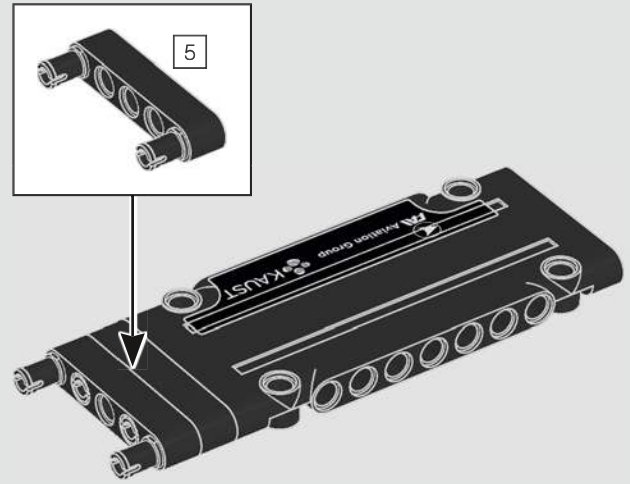

4

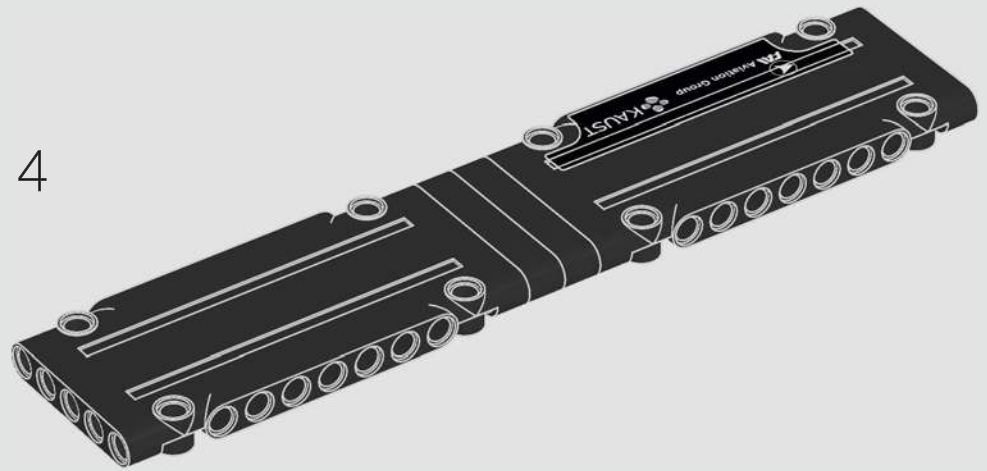

5

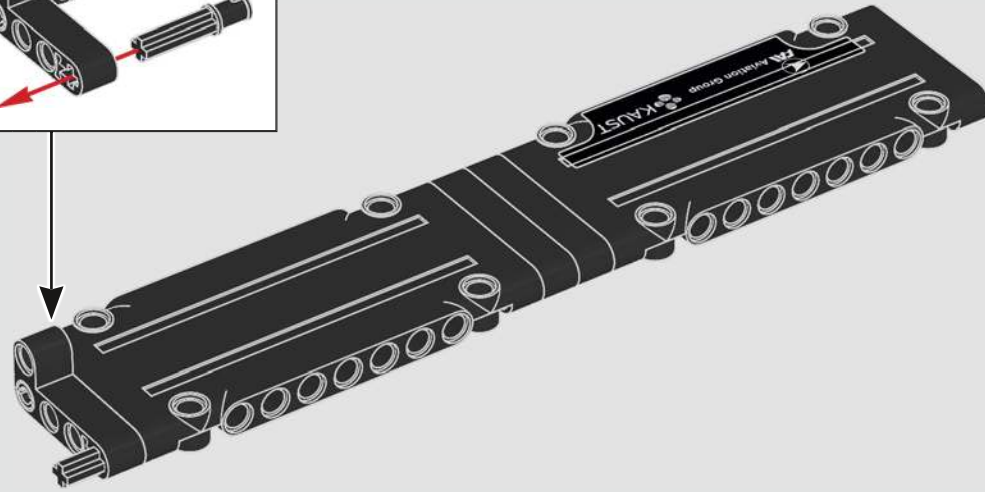
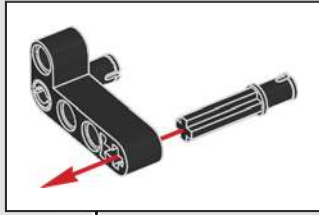

6

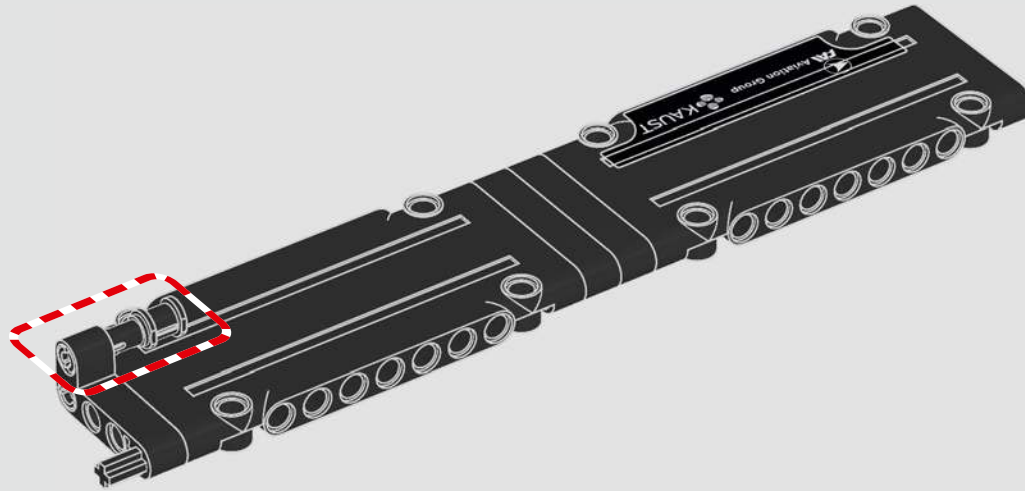

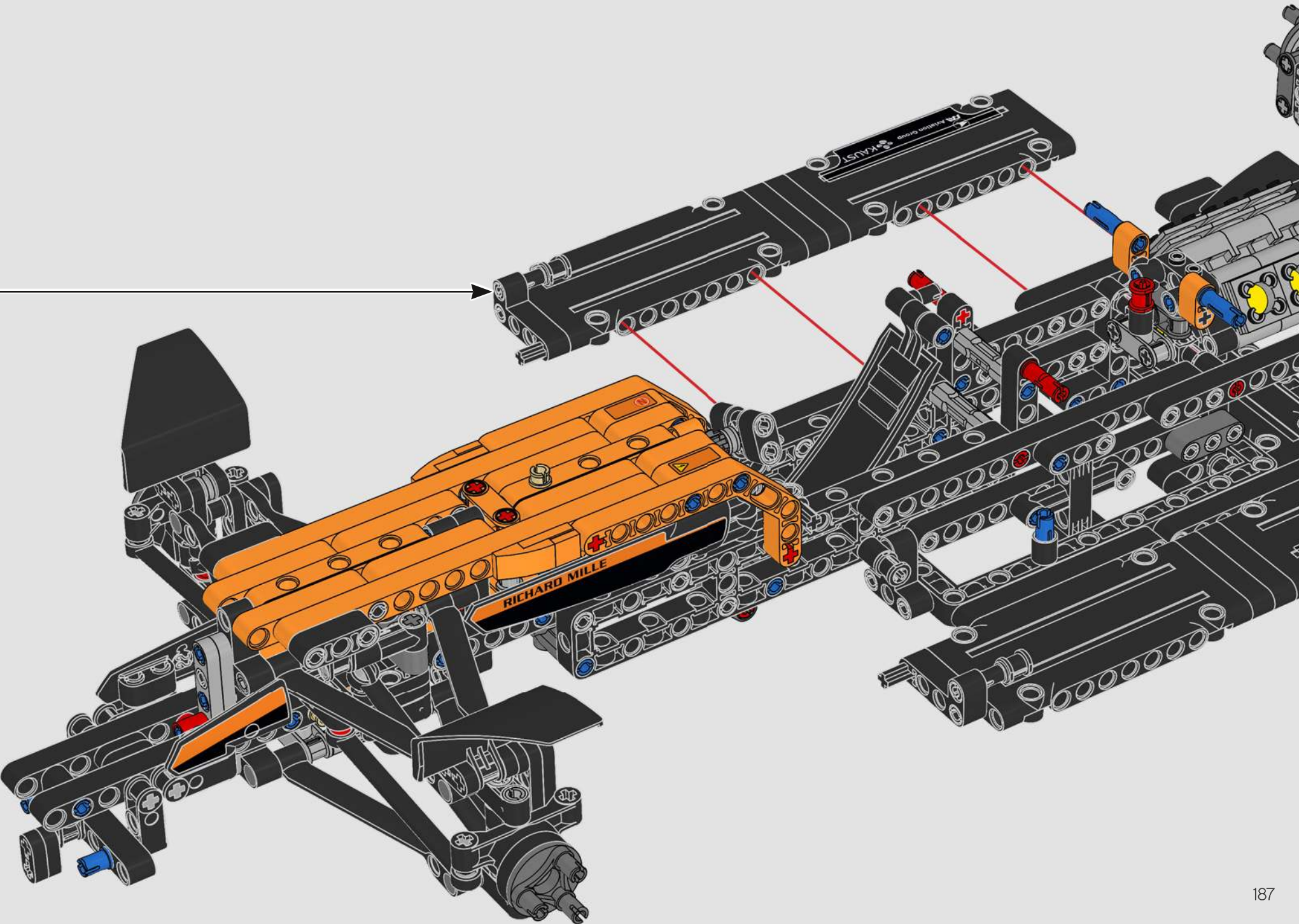

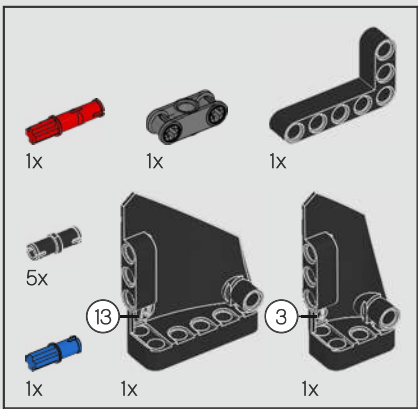

187

1

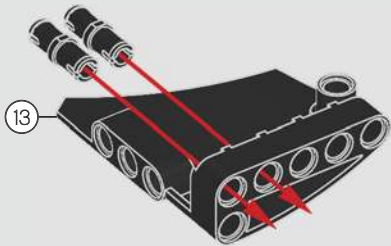

2

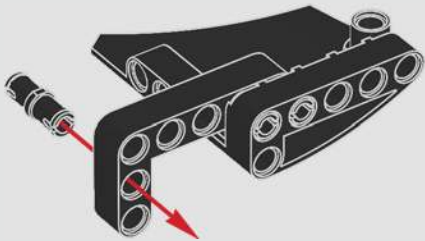

3

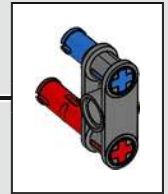
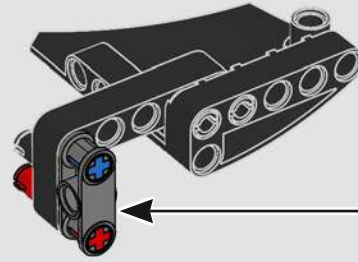

4

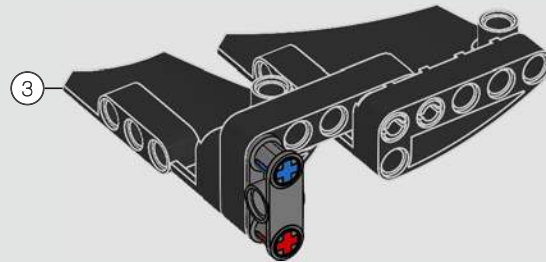

5

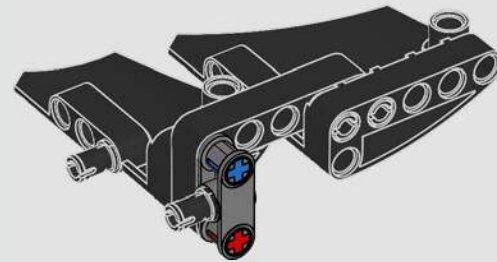

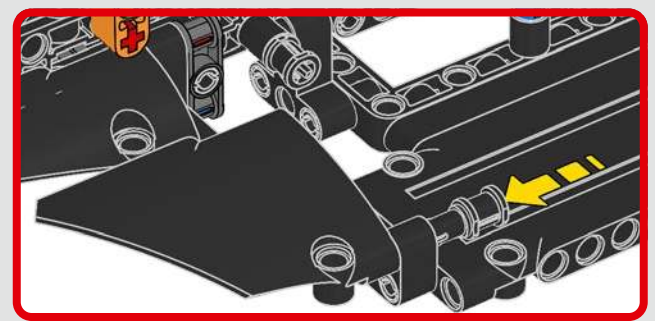
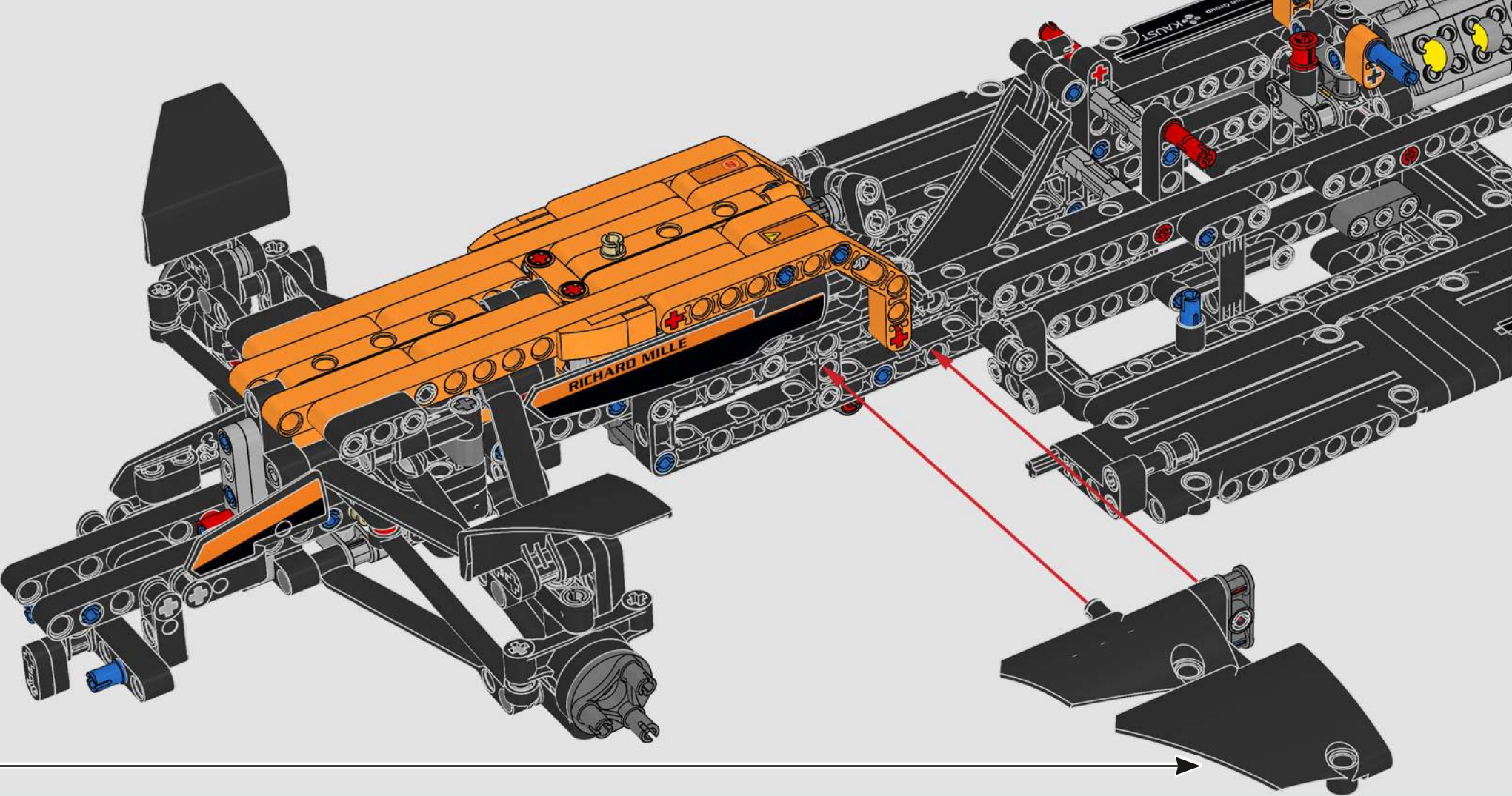

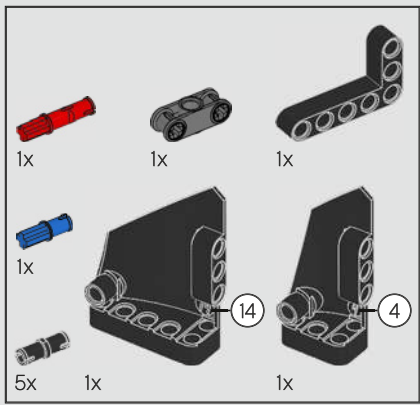

188

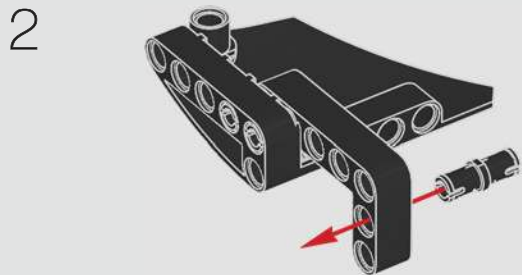
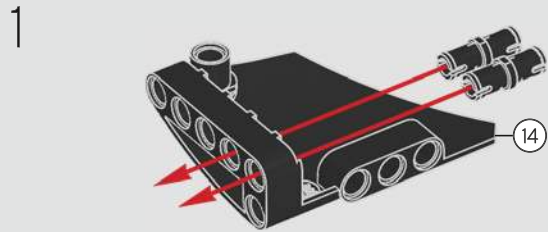

3

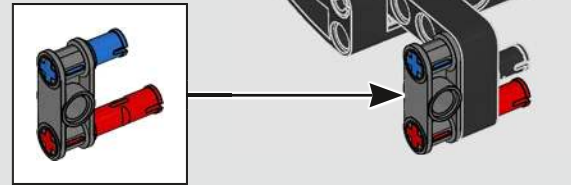

4

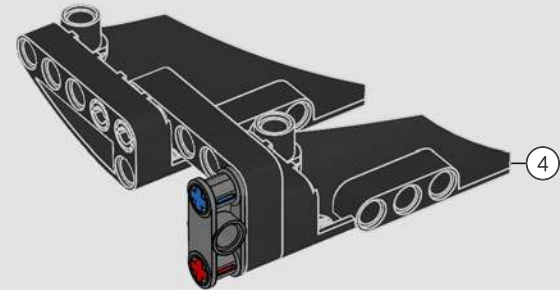

5

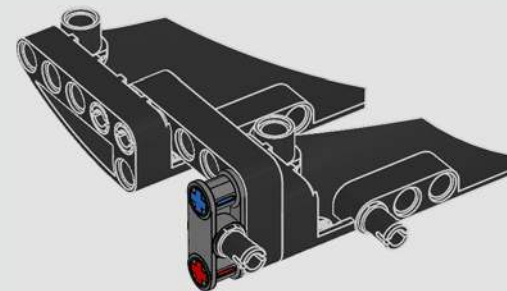

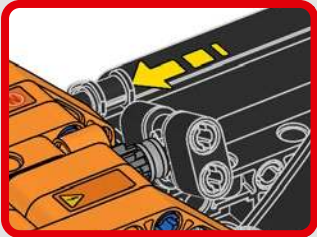
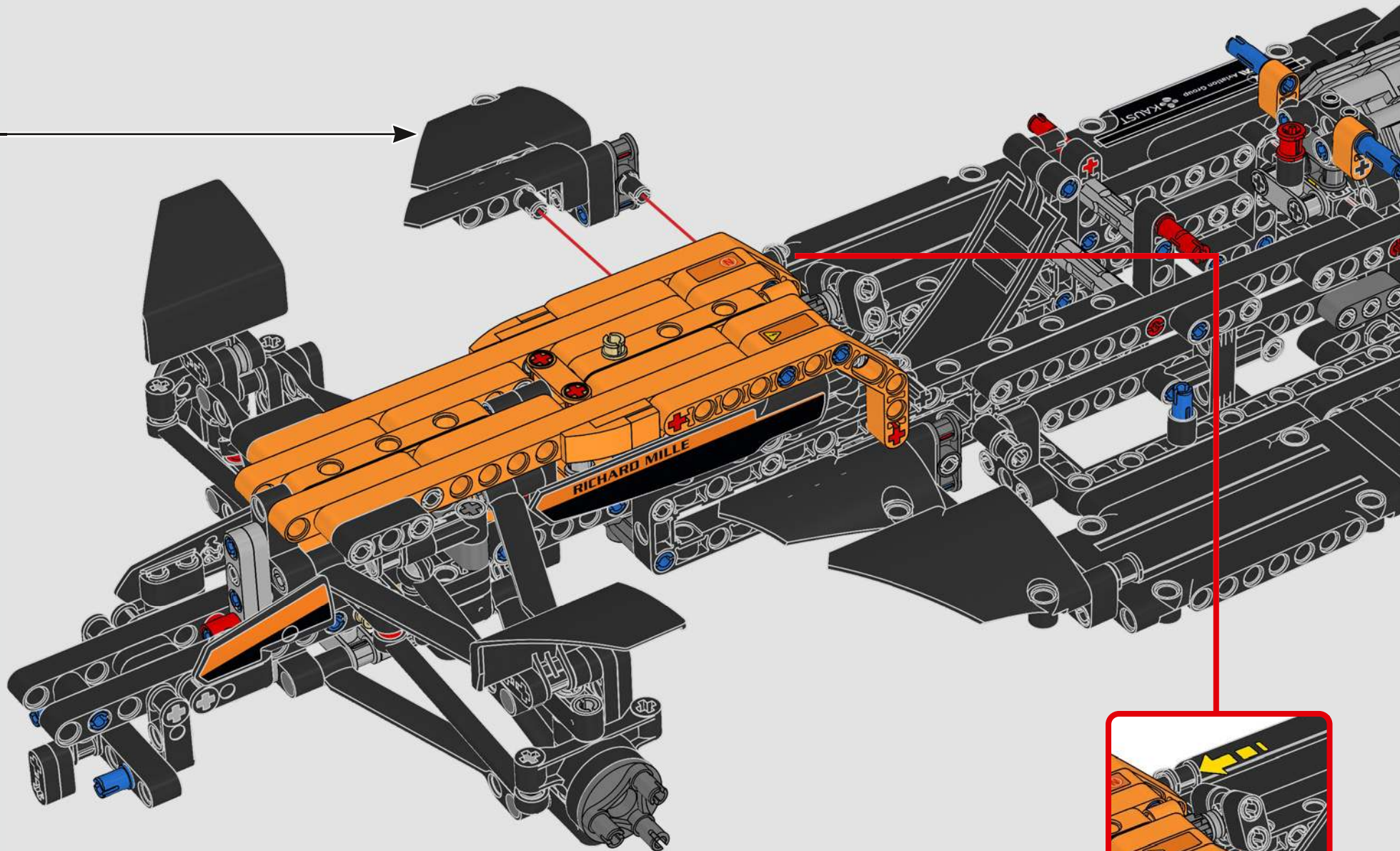



2x

189

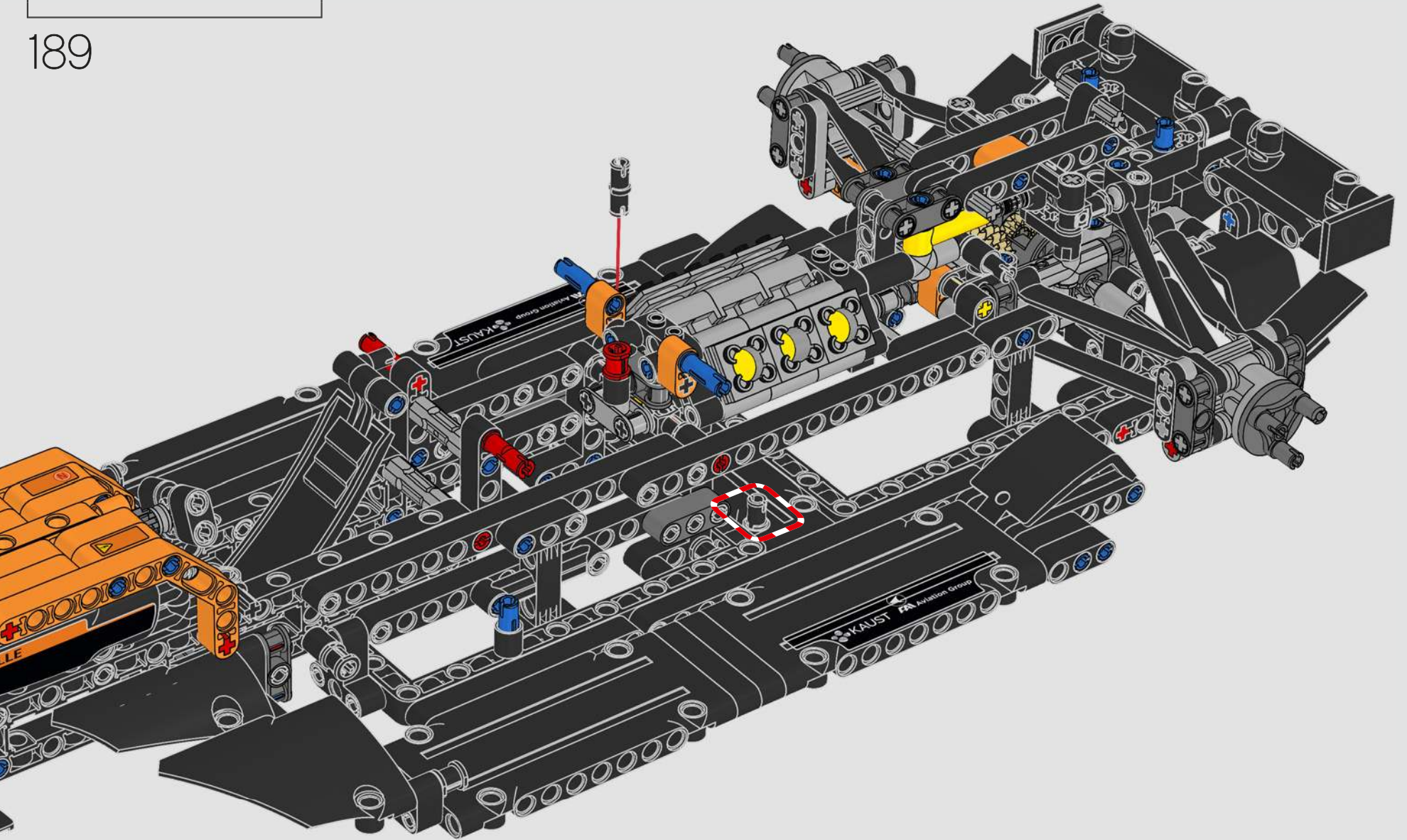

192

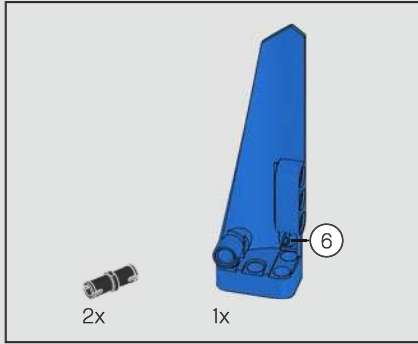
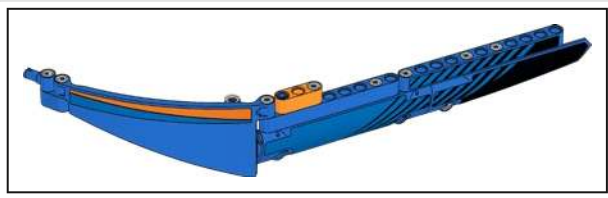

190

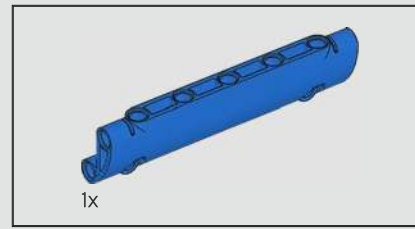
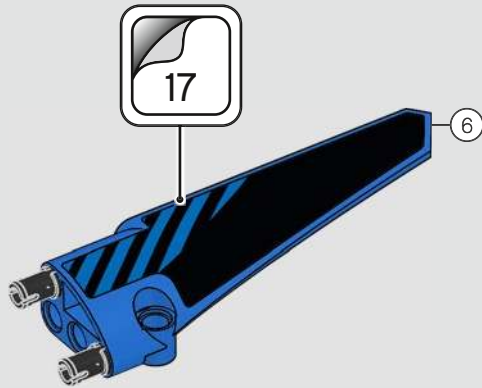

191

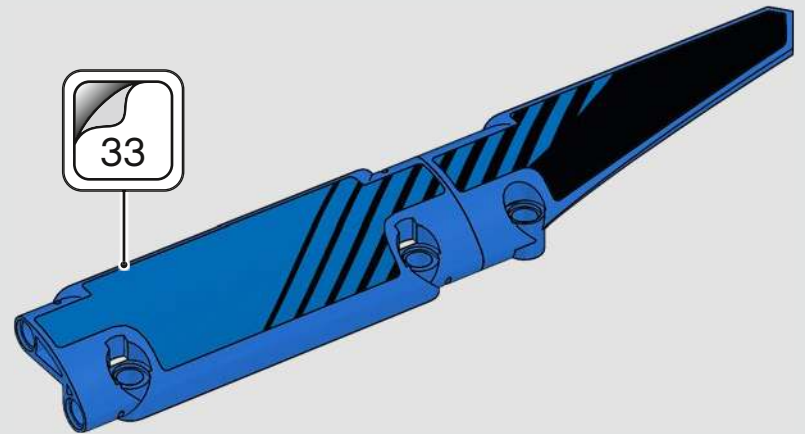

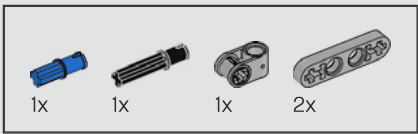

192

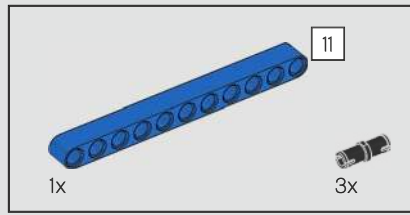
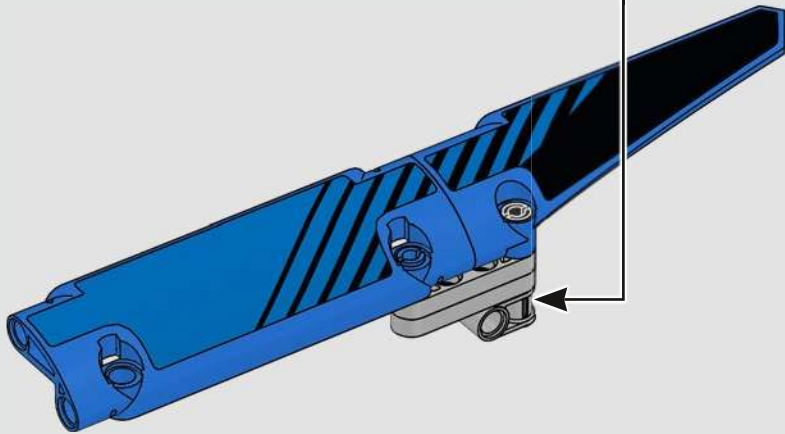
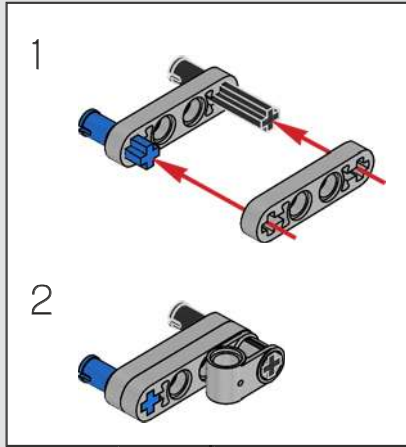

193

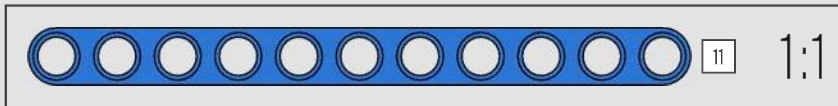
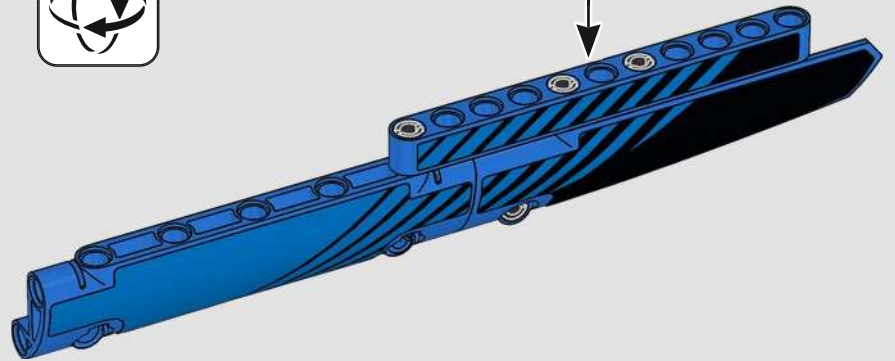

194

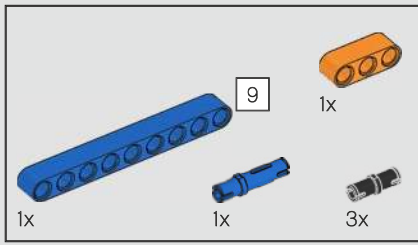

194

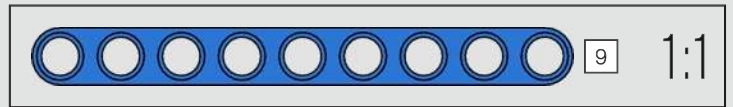
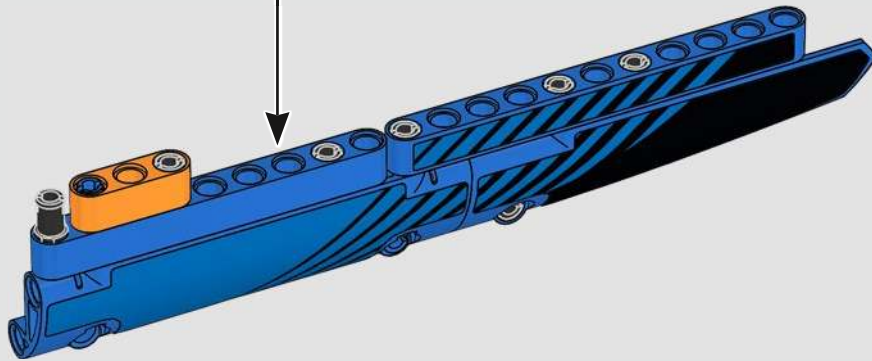
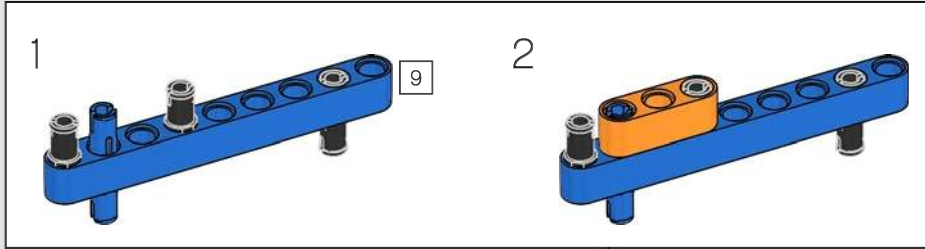



1x

195

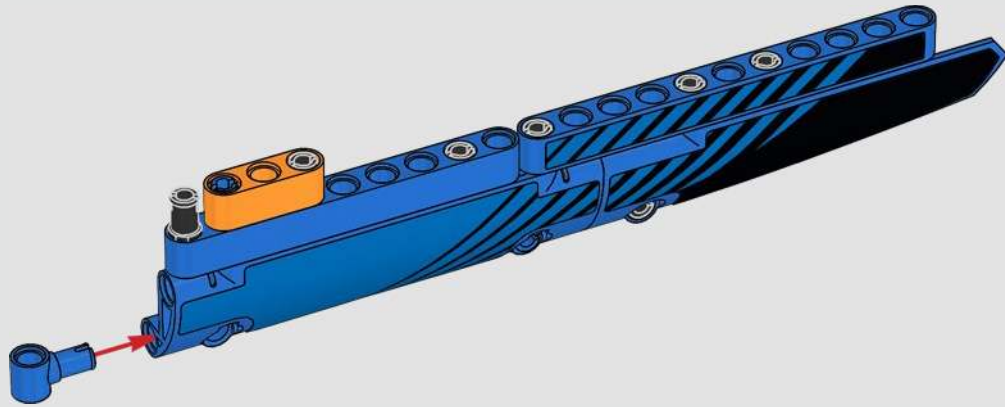

5

1x

1x

196

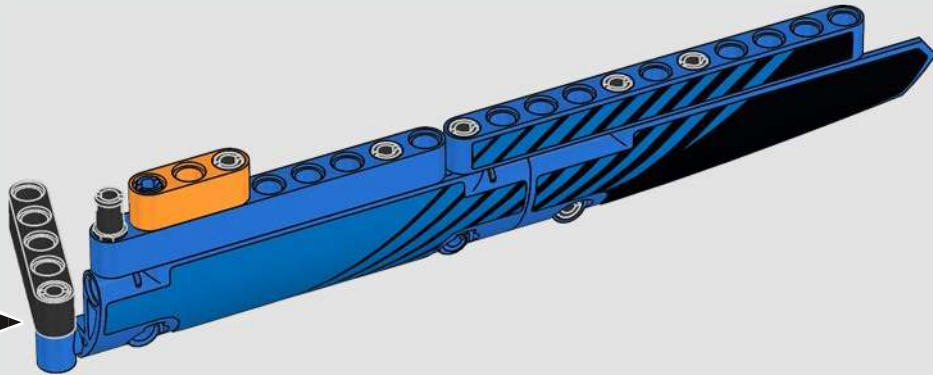

5



5

1:1

196



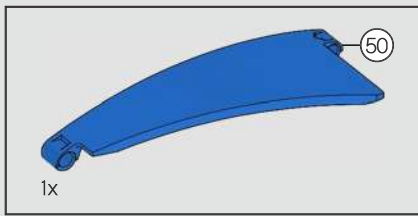

197

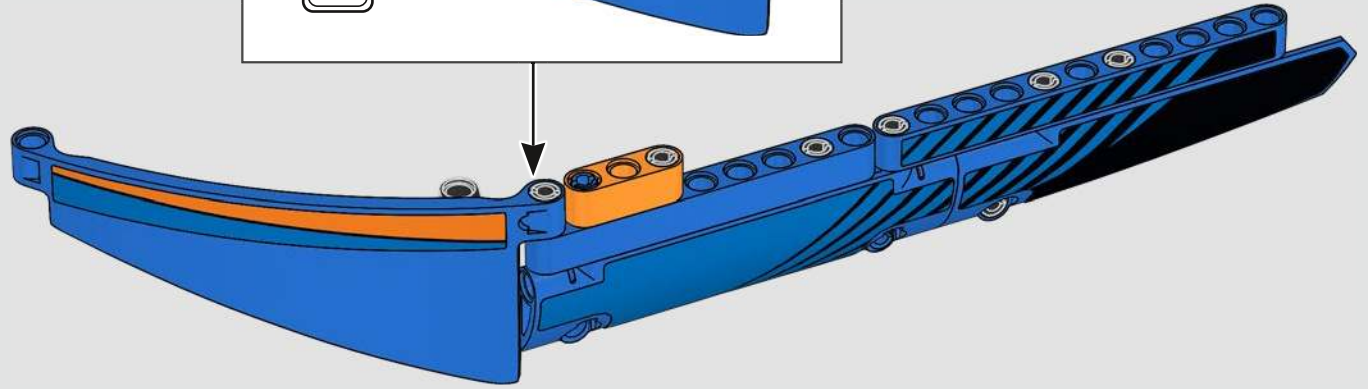
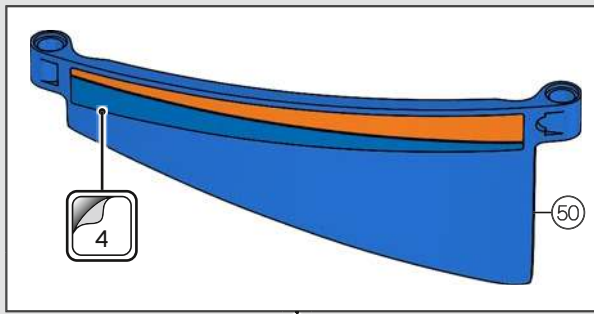

198

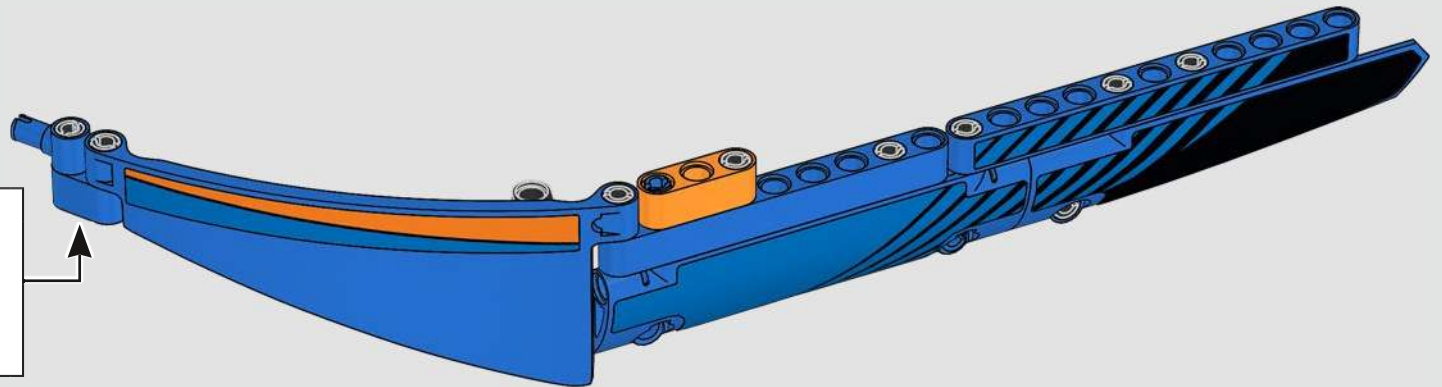
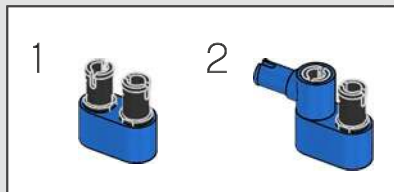

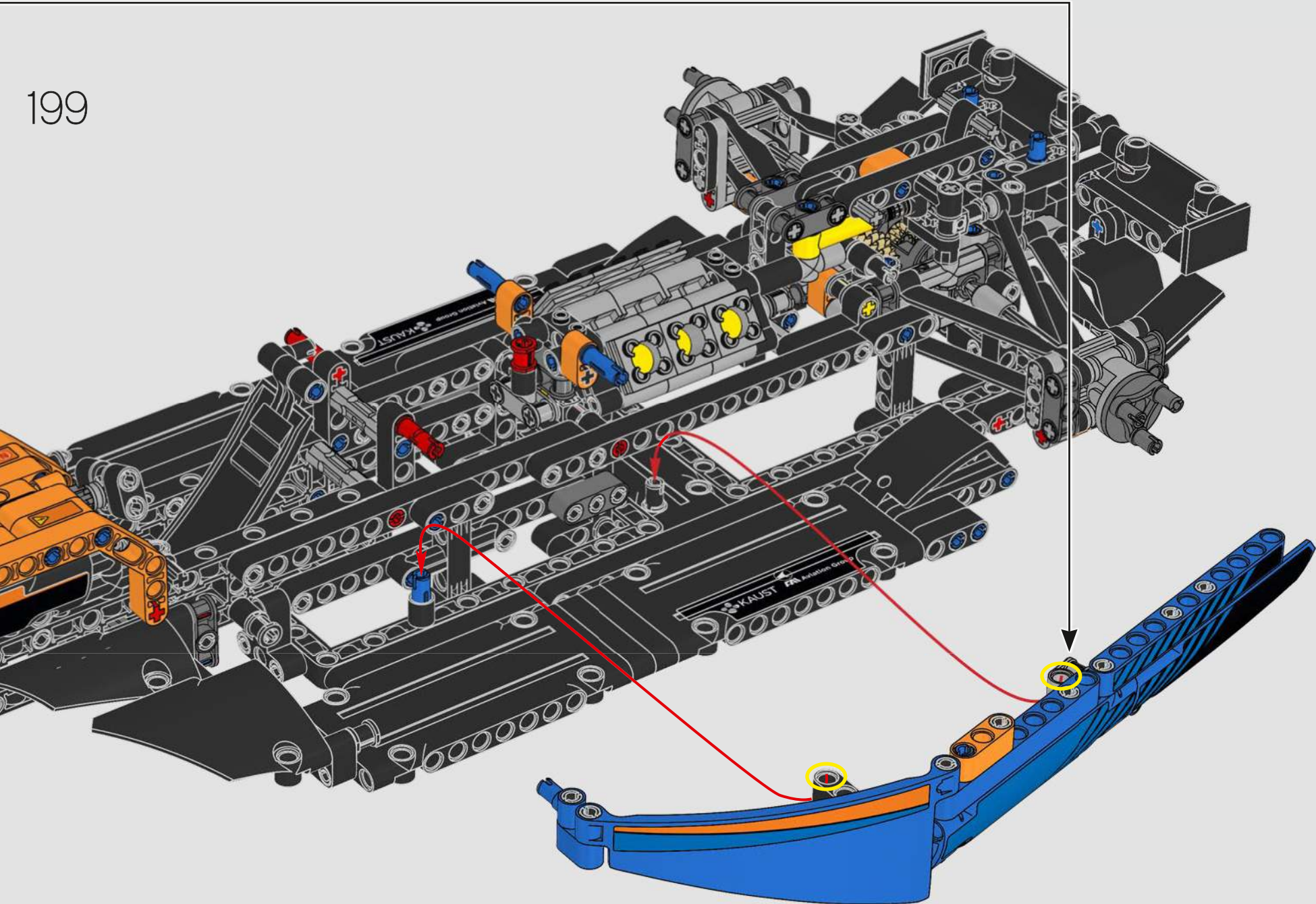

200

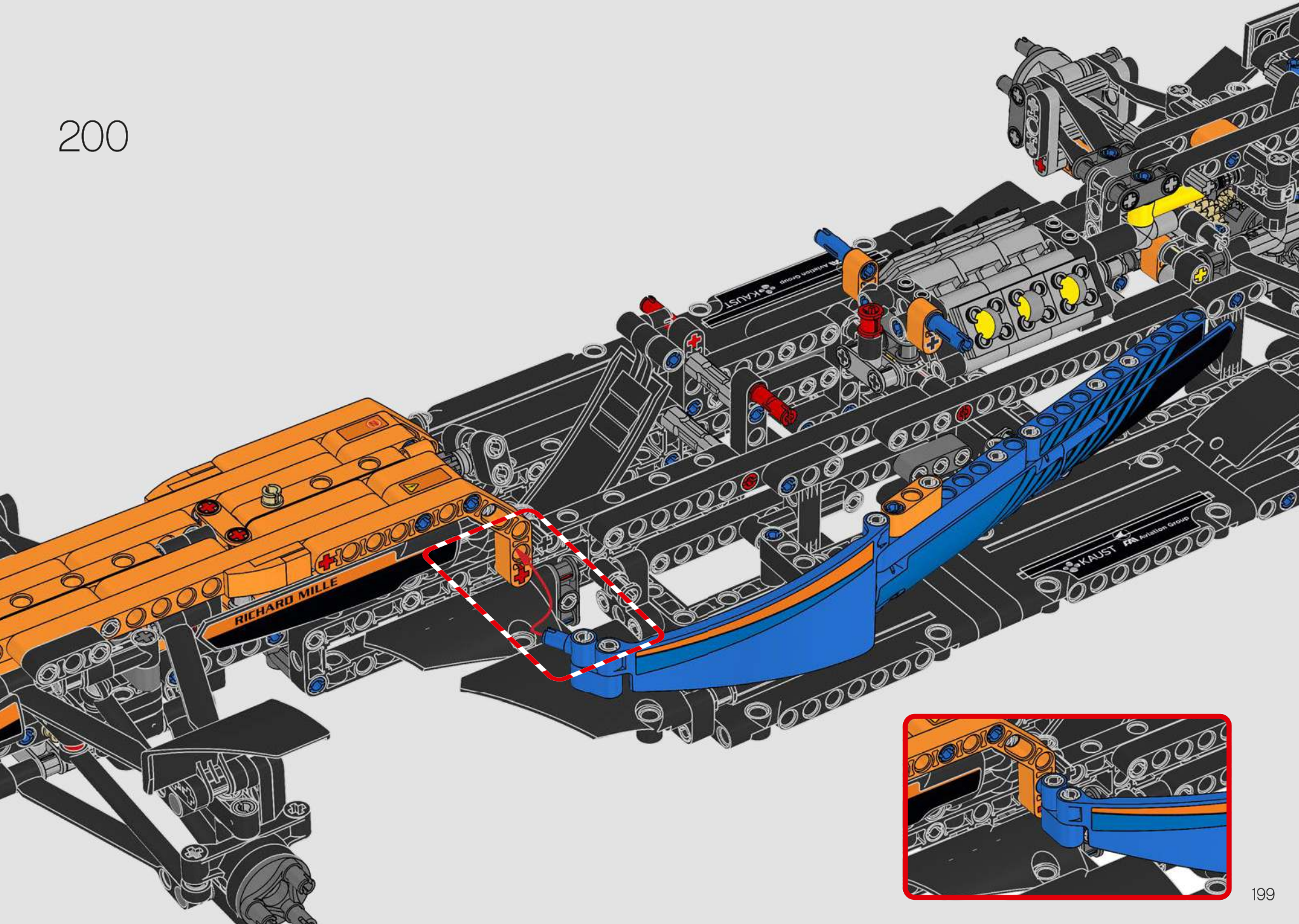

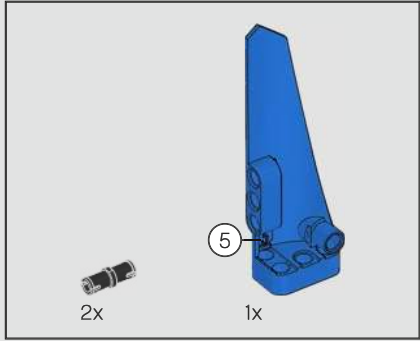
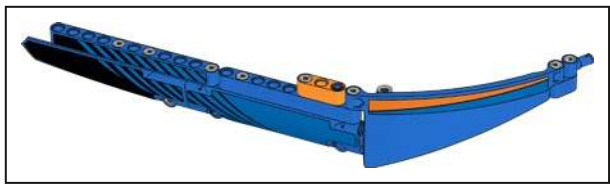

201

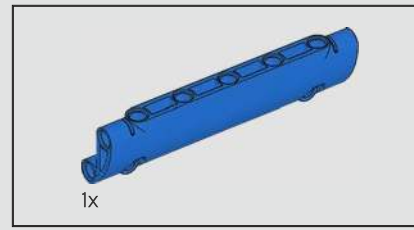
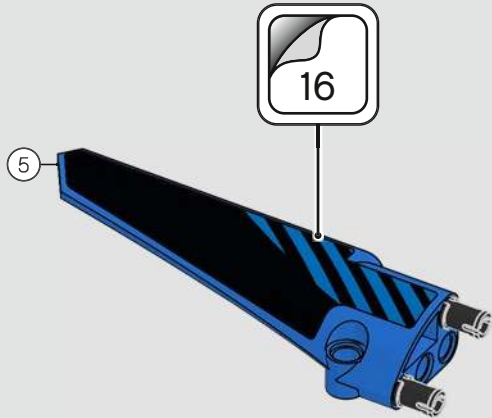

202

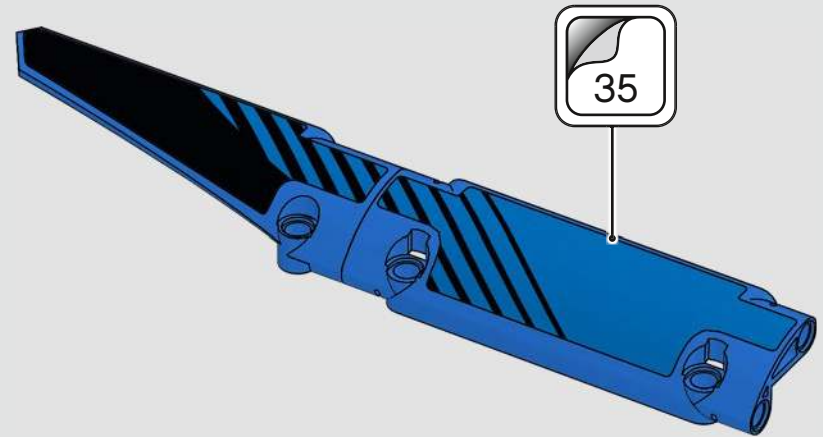

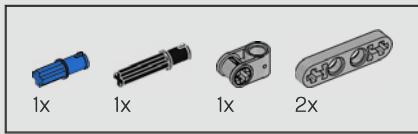

203

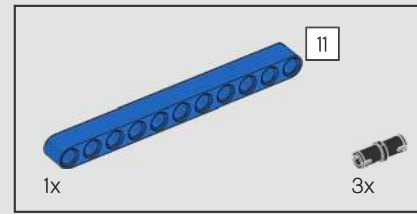
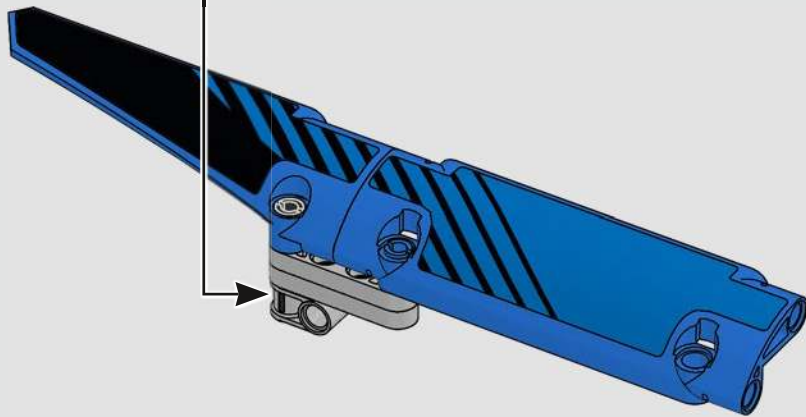
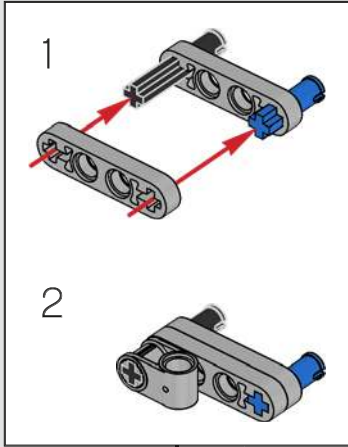

204

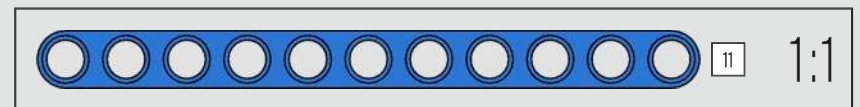
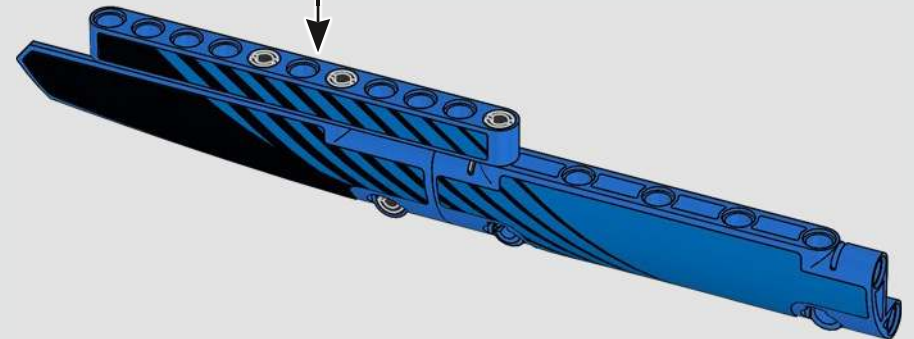

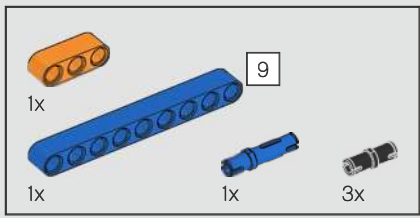

205

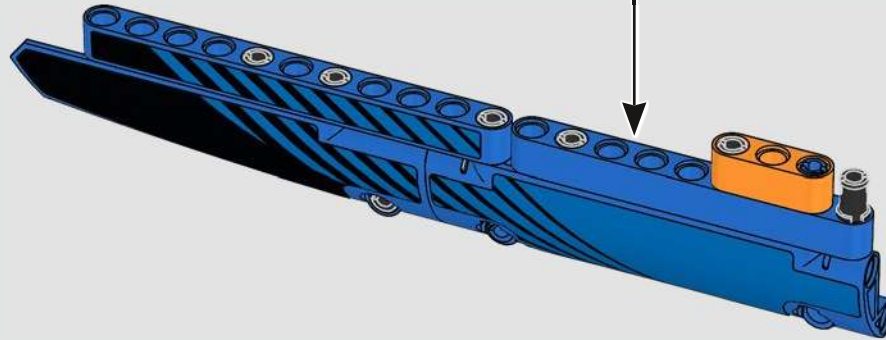
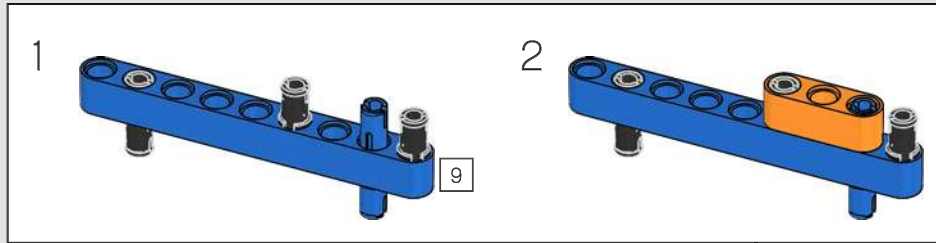

202

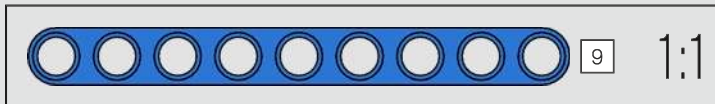

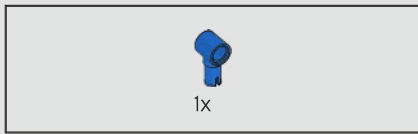

206

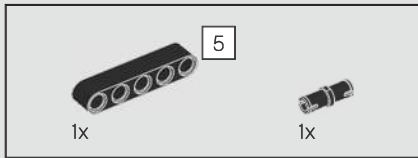
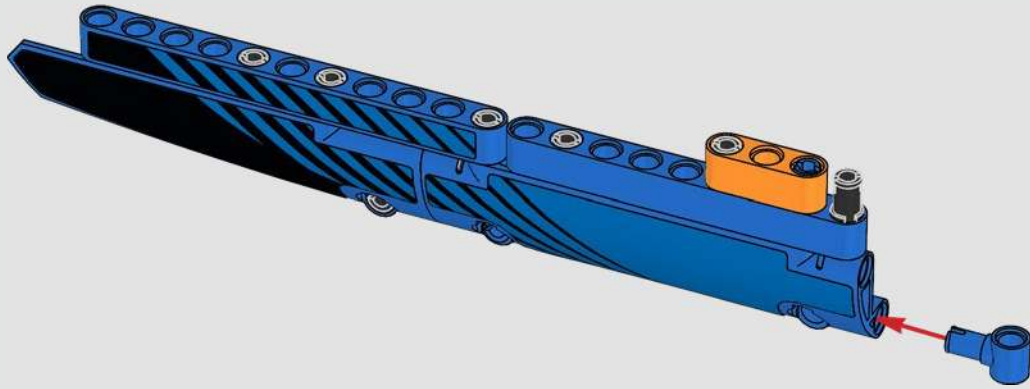

207

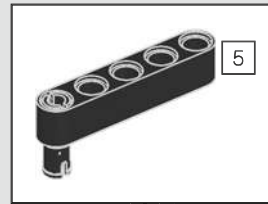

1:1

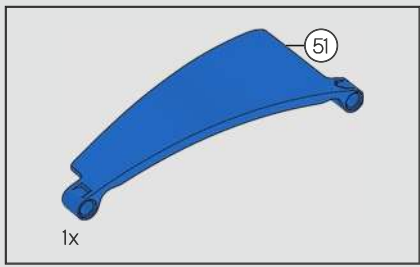

208

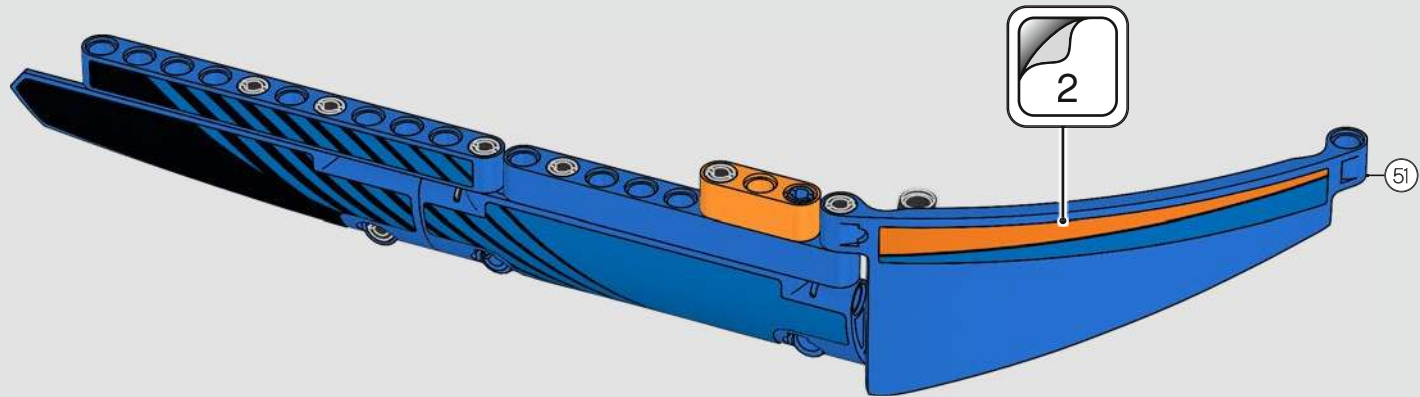



209

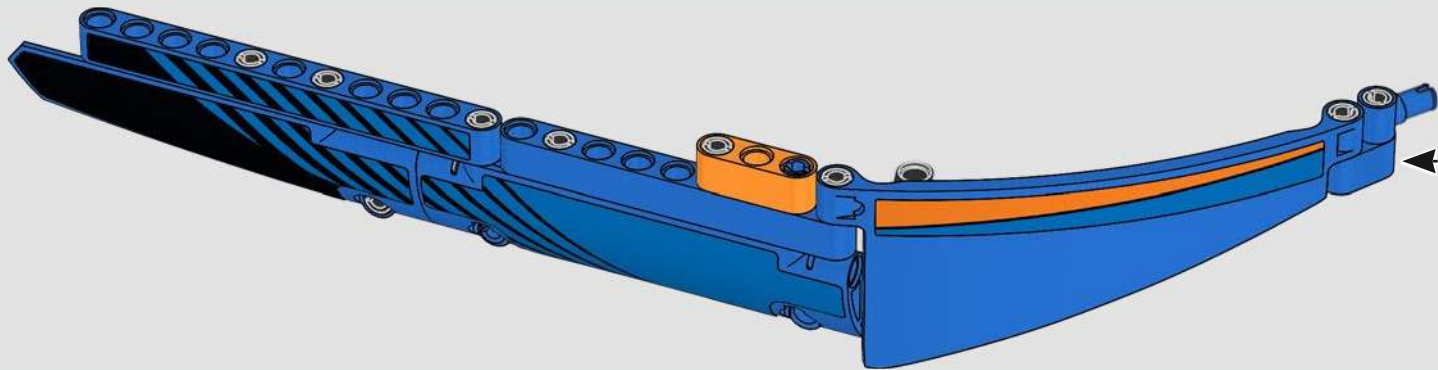
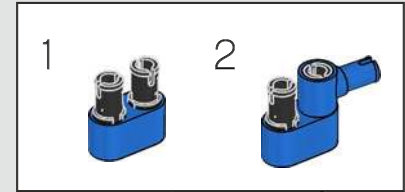

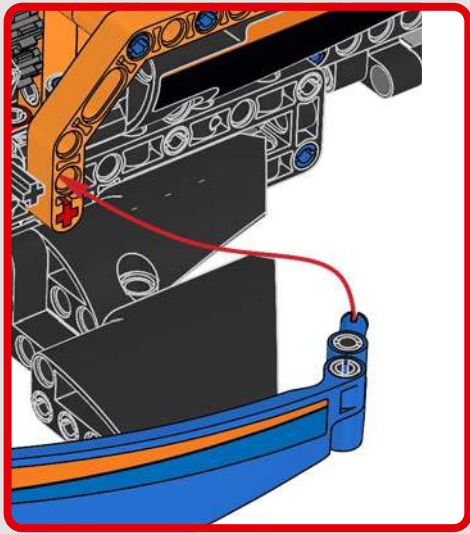

210

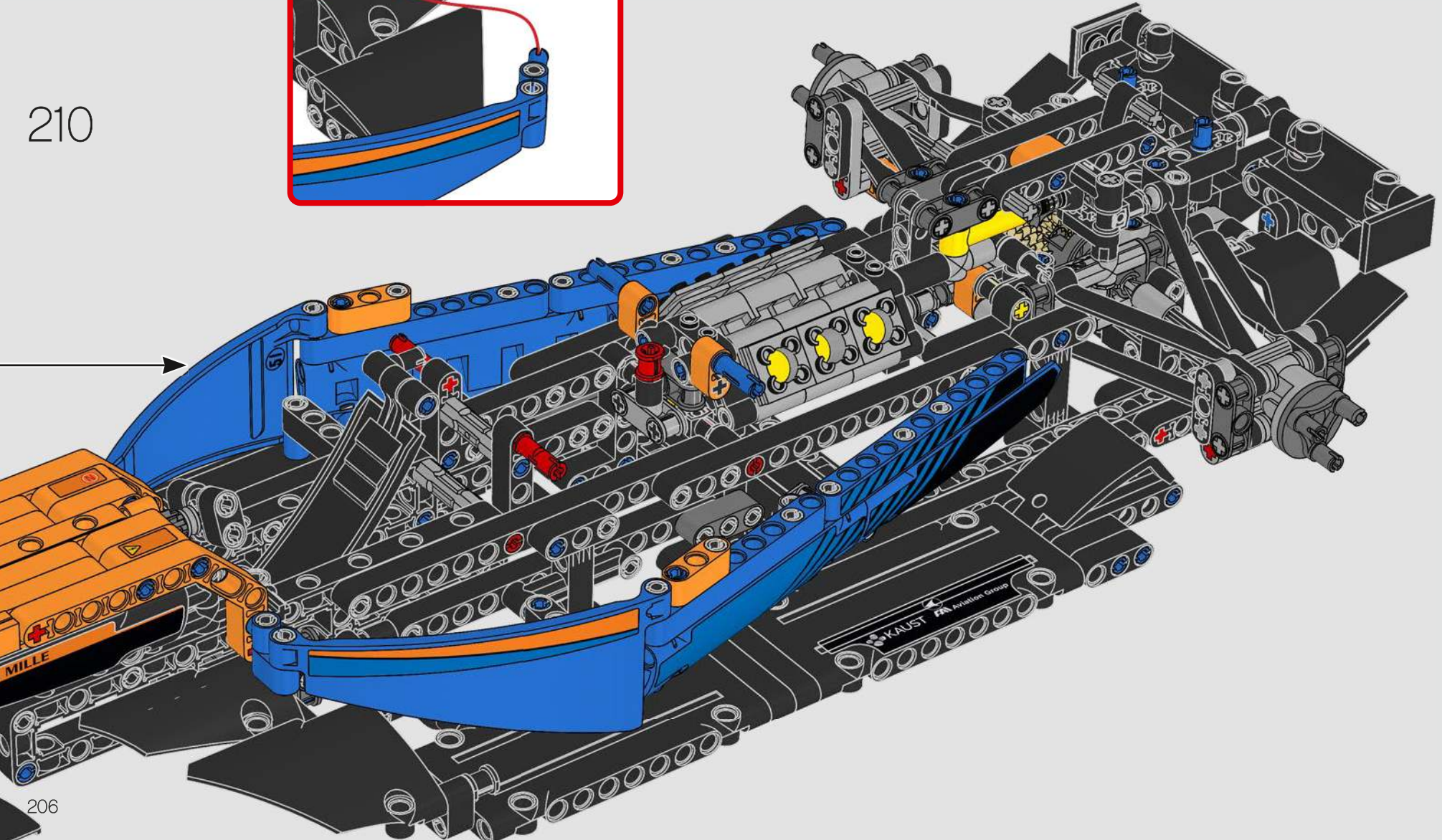

206

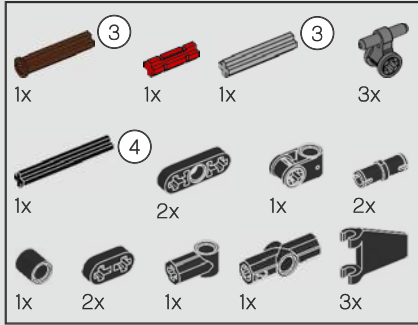

211

1

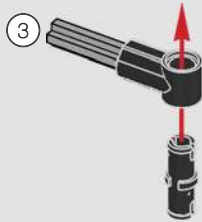

2

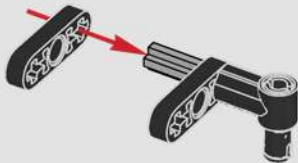

3

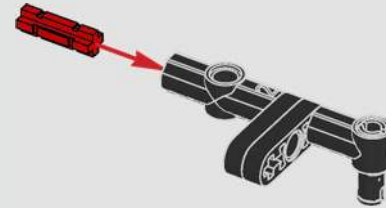

4

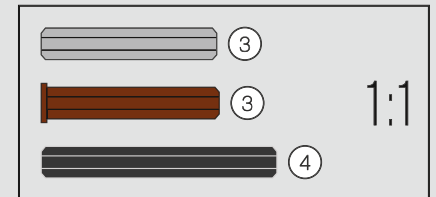
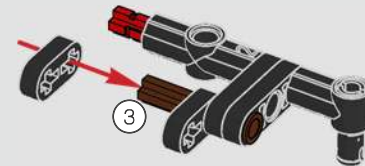

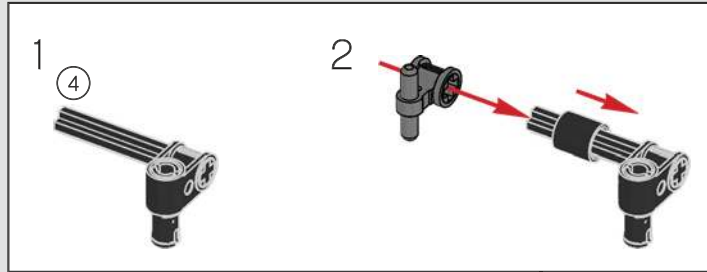

5

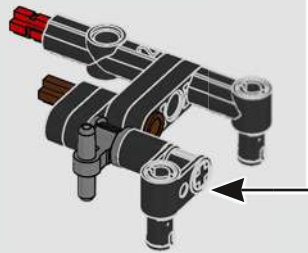

6

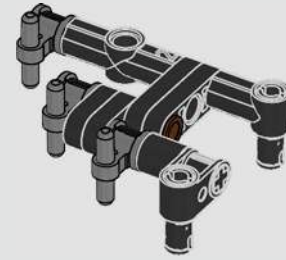

7

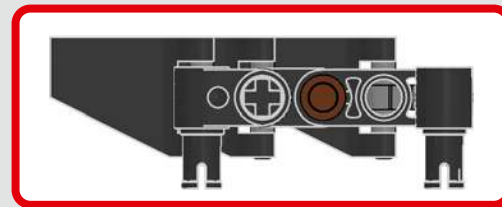
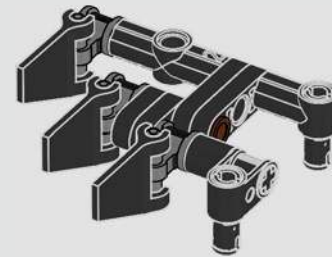

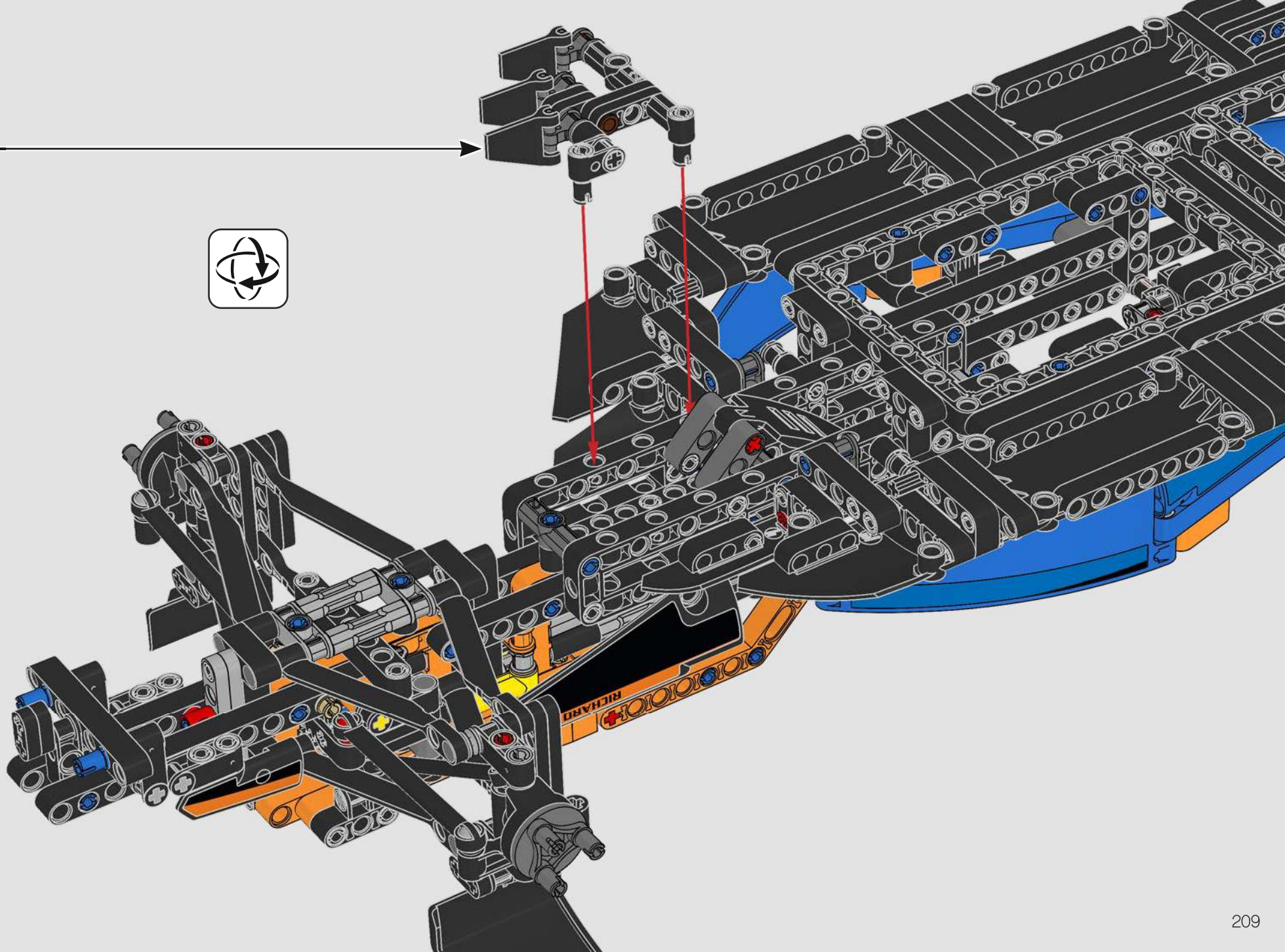

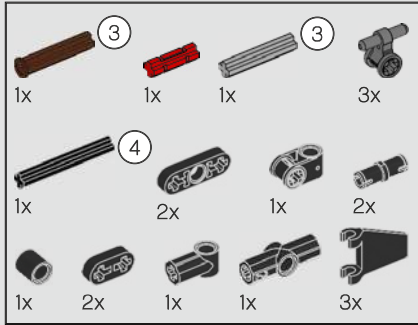

212

1

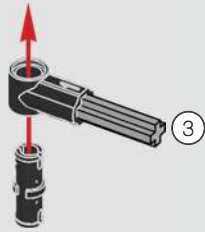

2

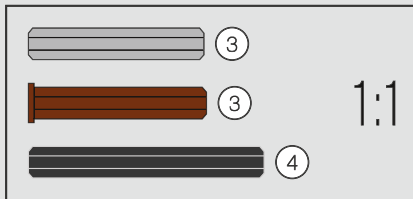
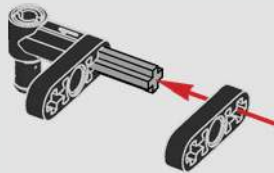

210

3



4

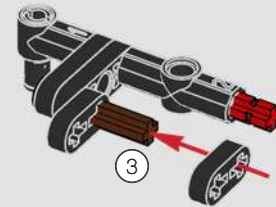

5

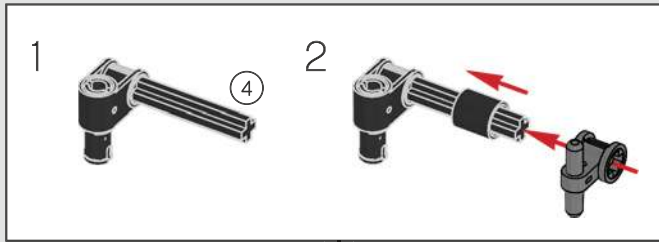
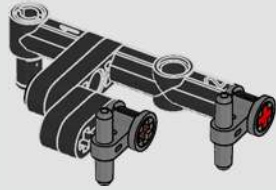

6

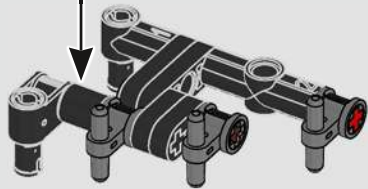

7

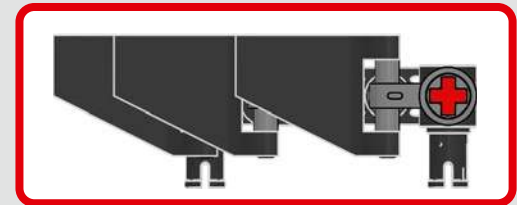
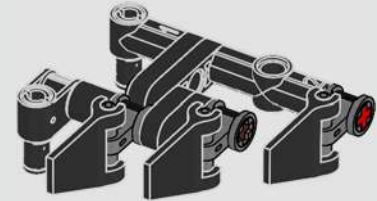

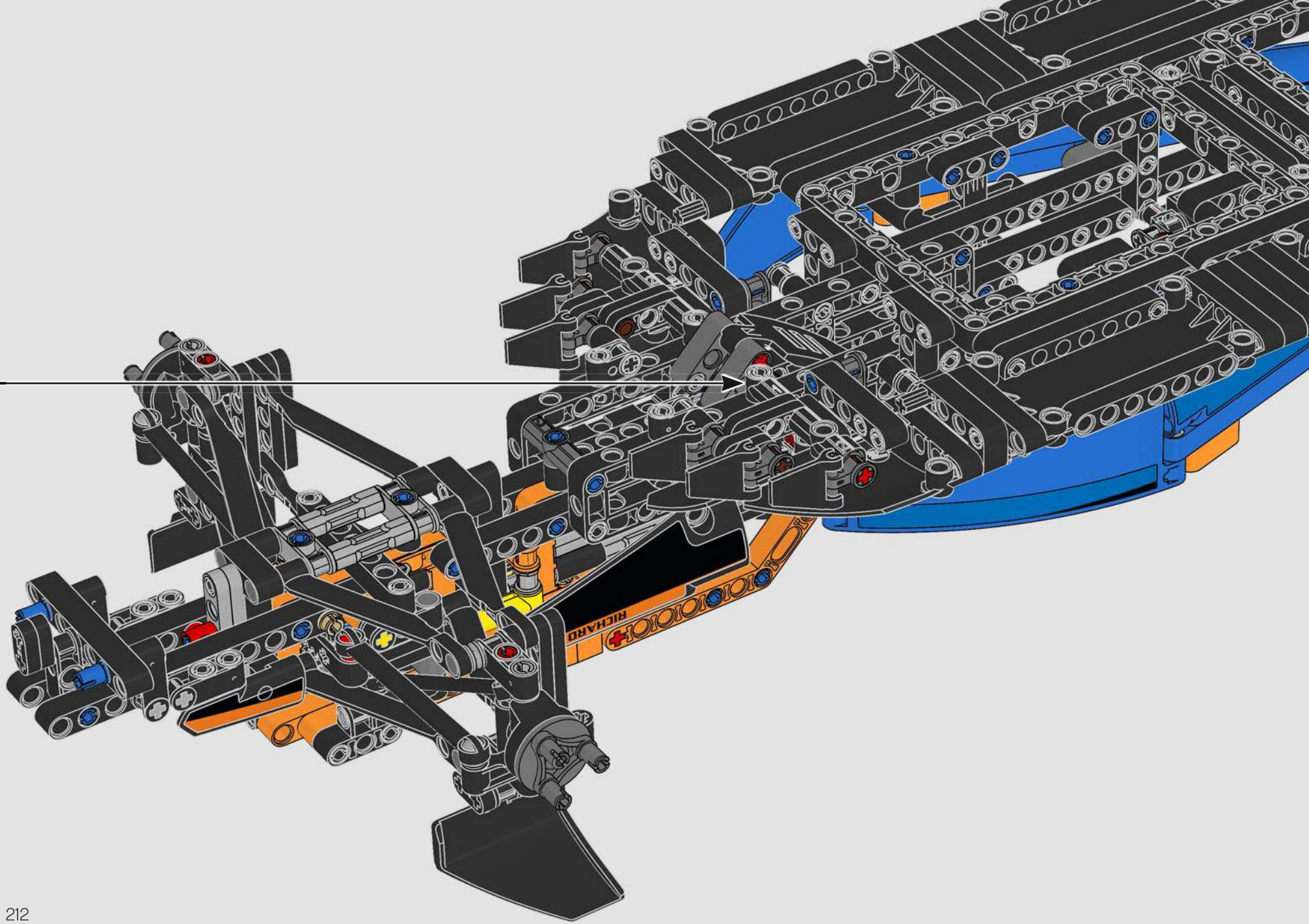



213

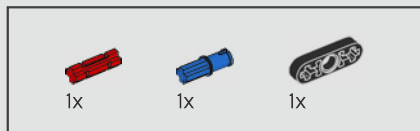
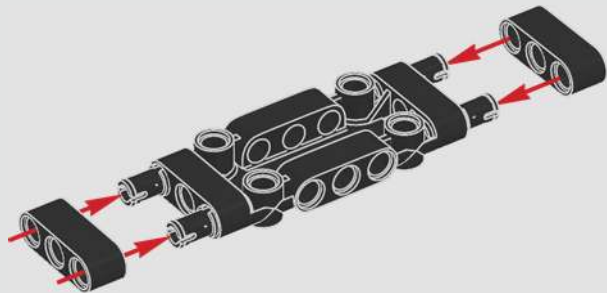

214

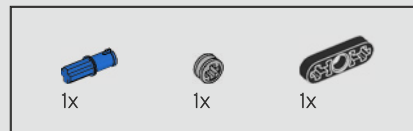
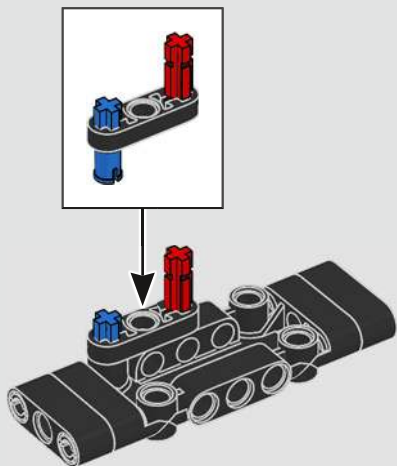

215

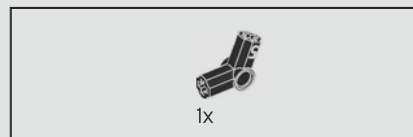
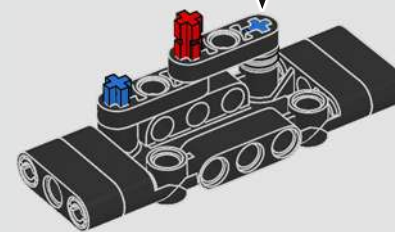
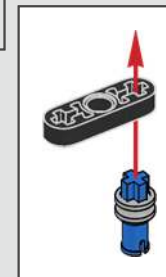

216

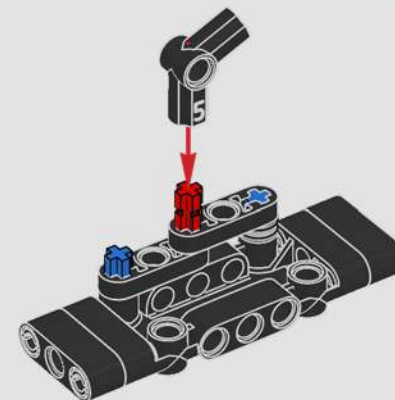

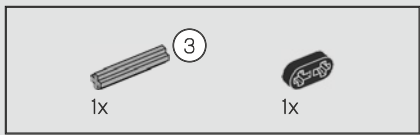

217

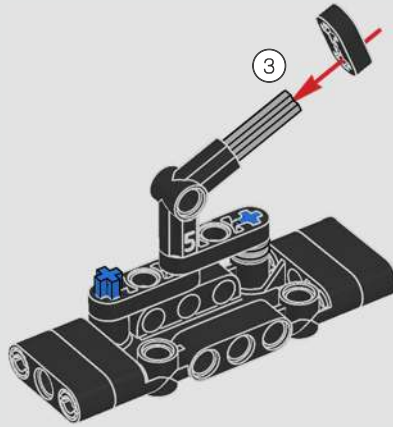

218



214

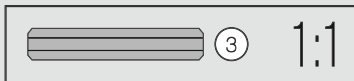

219

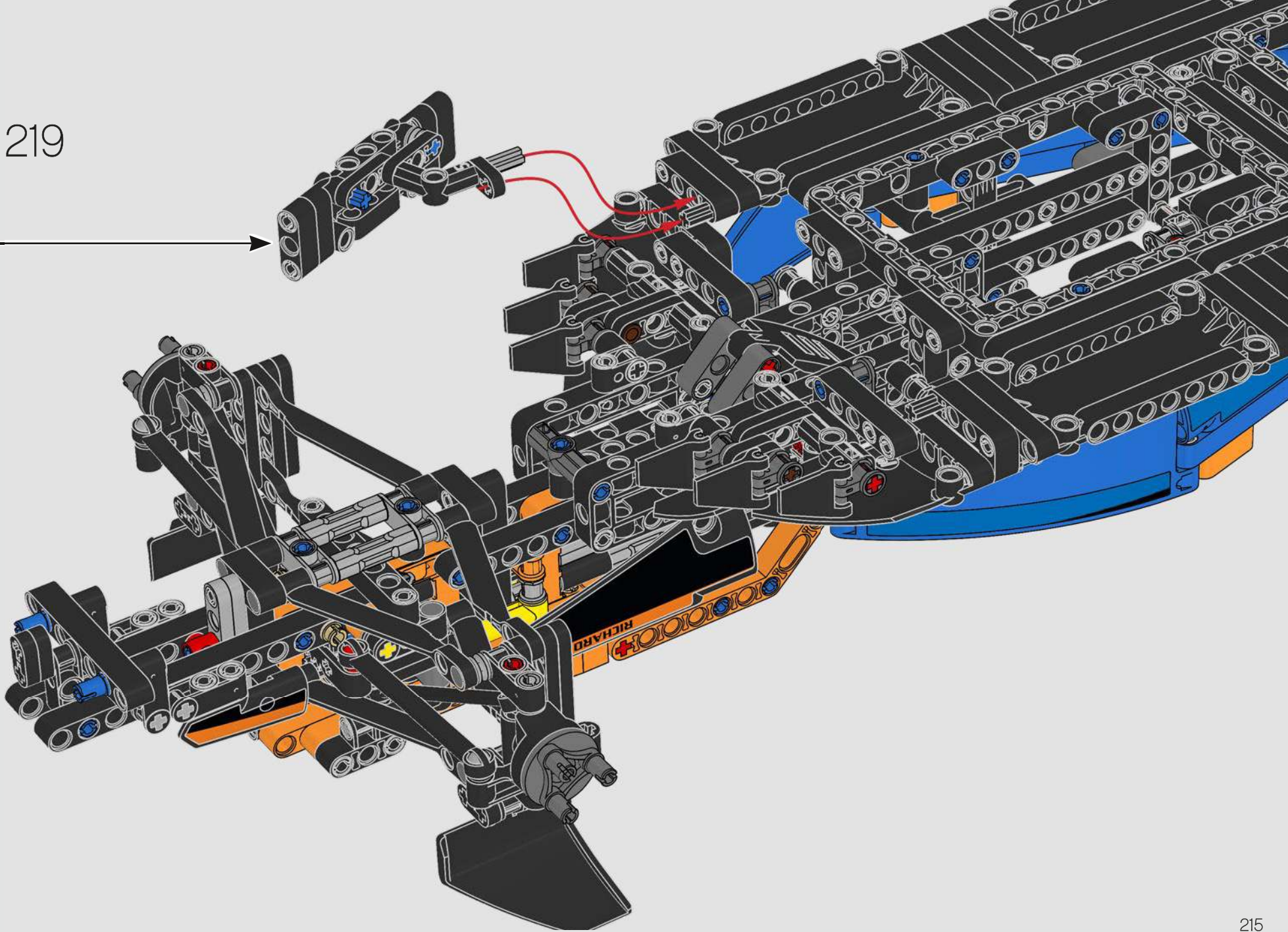

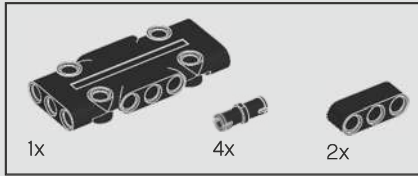

220

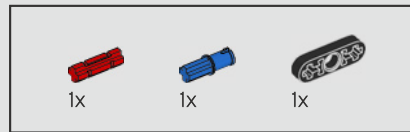
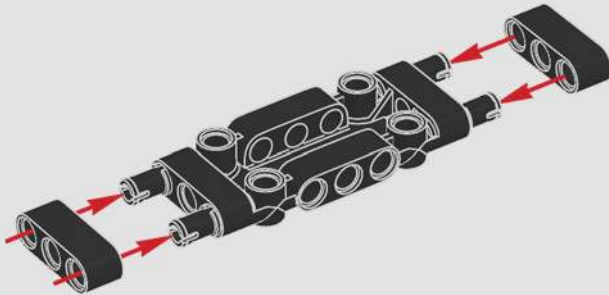

221

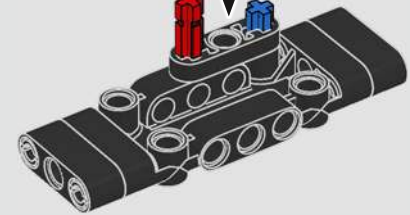

222

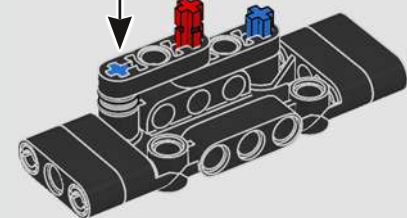
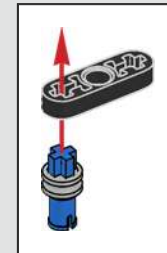



223

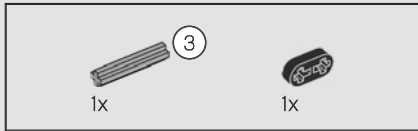
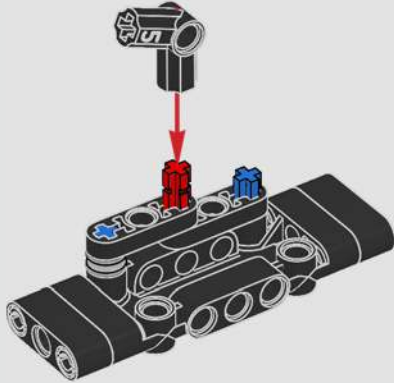

224

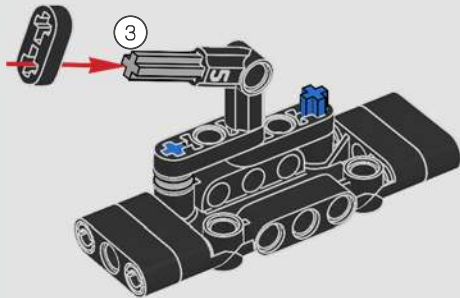

225

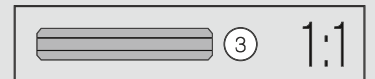
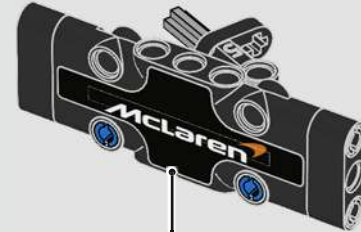

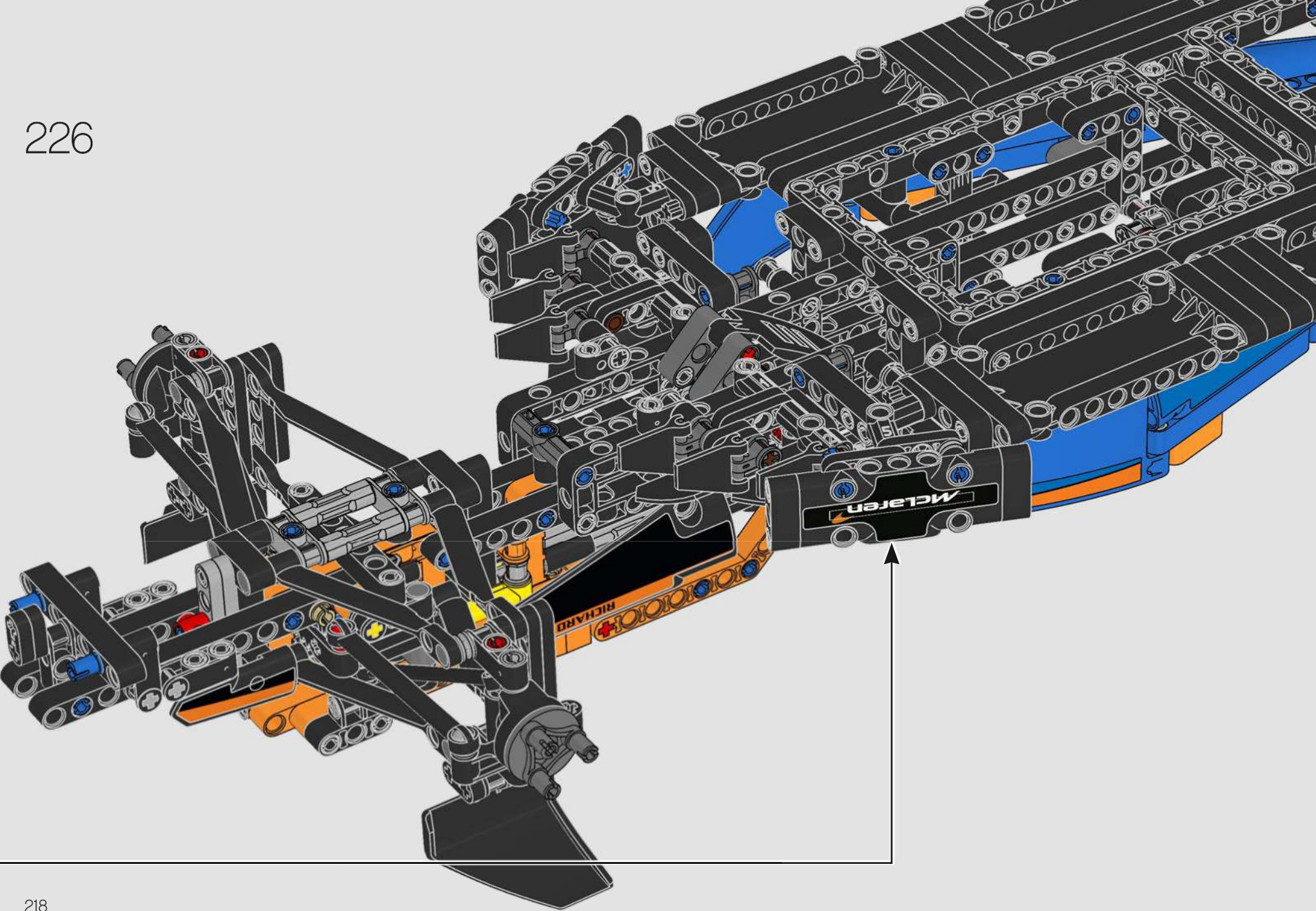



227

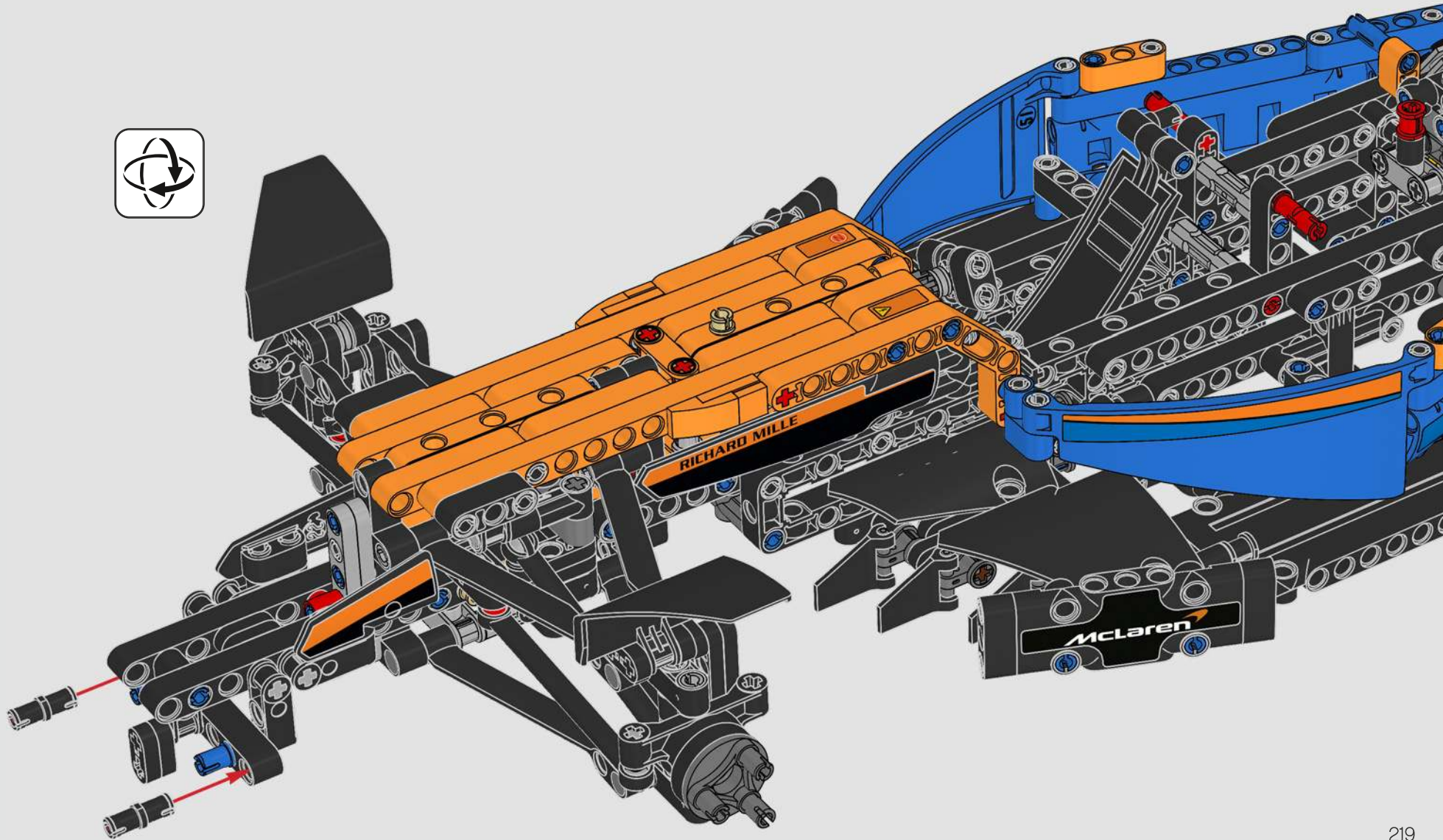

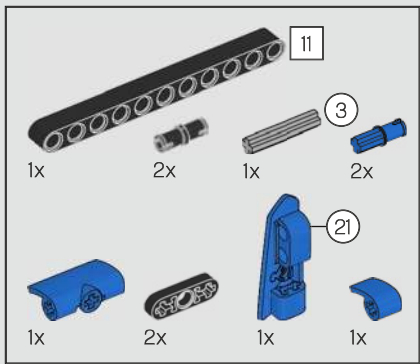

228

1

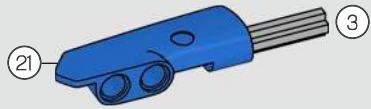

2

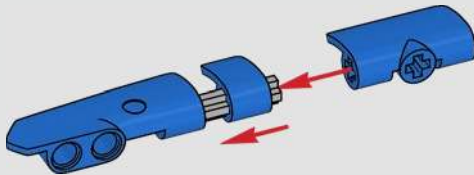

220

3

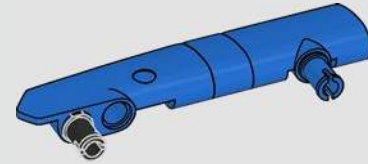

1



2



4

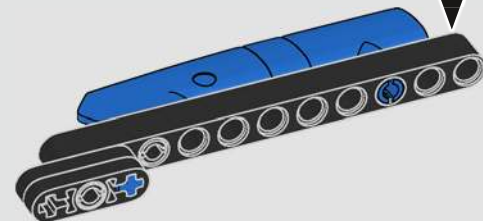

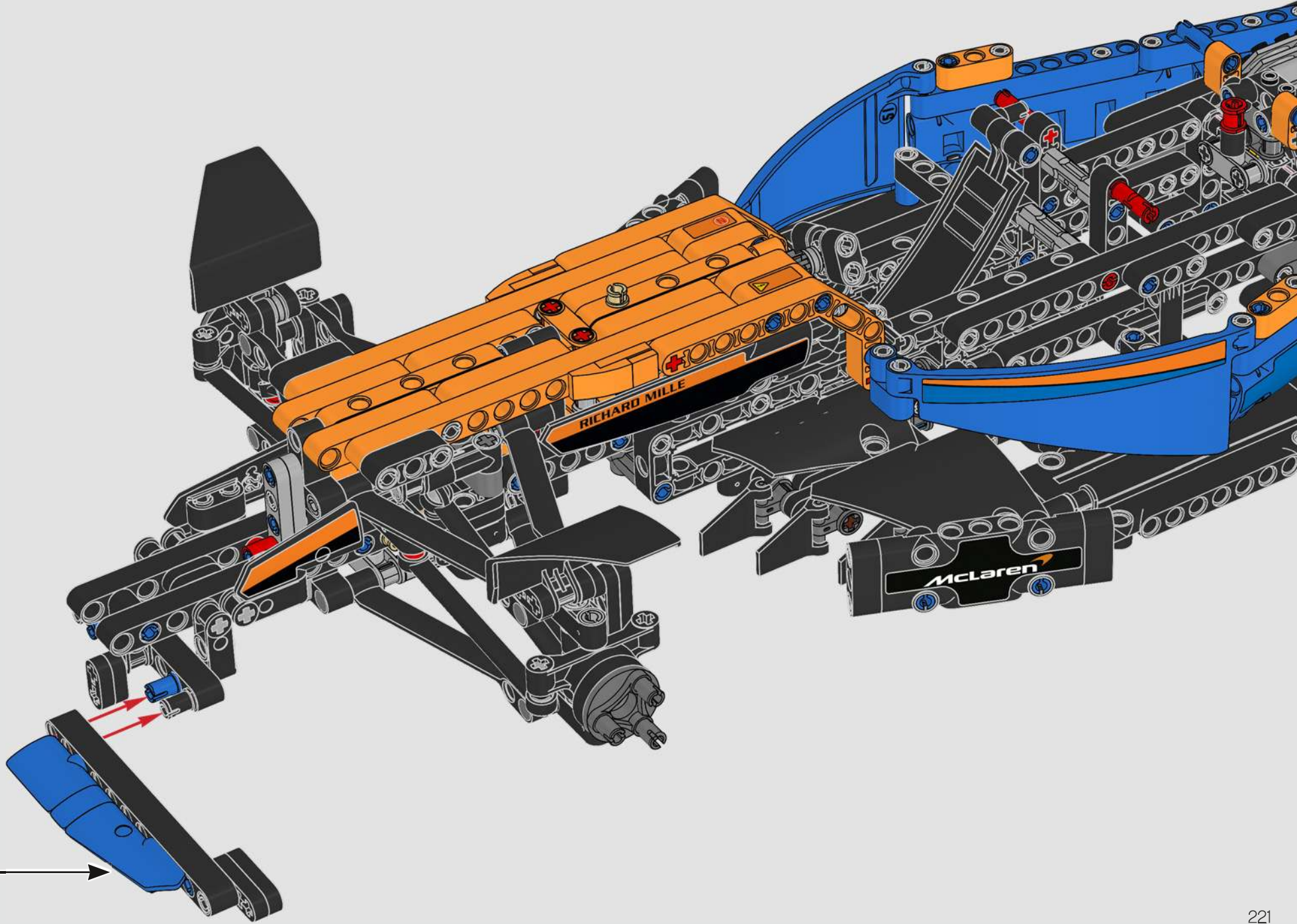

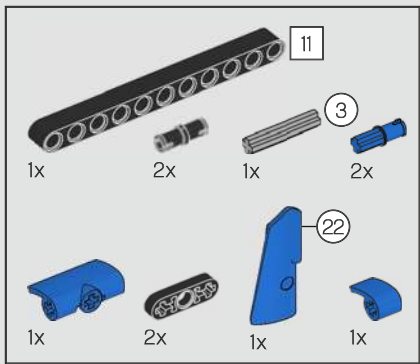

229

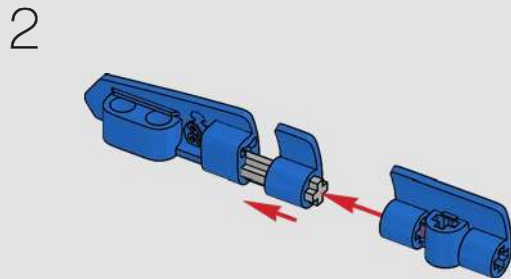
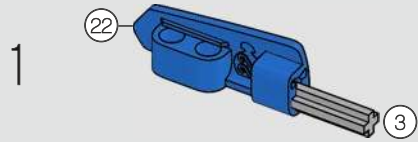

222

3

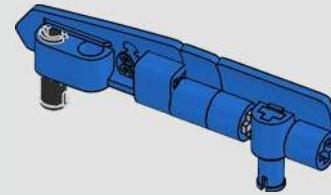

4

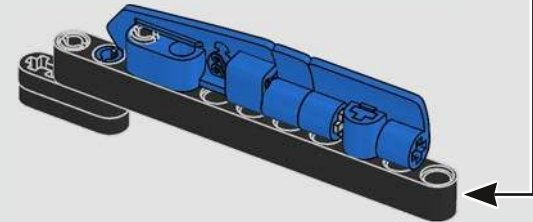

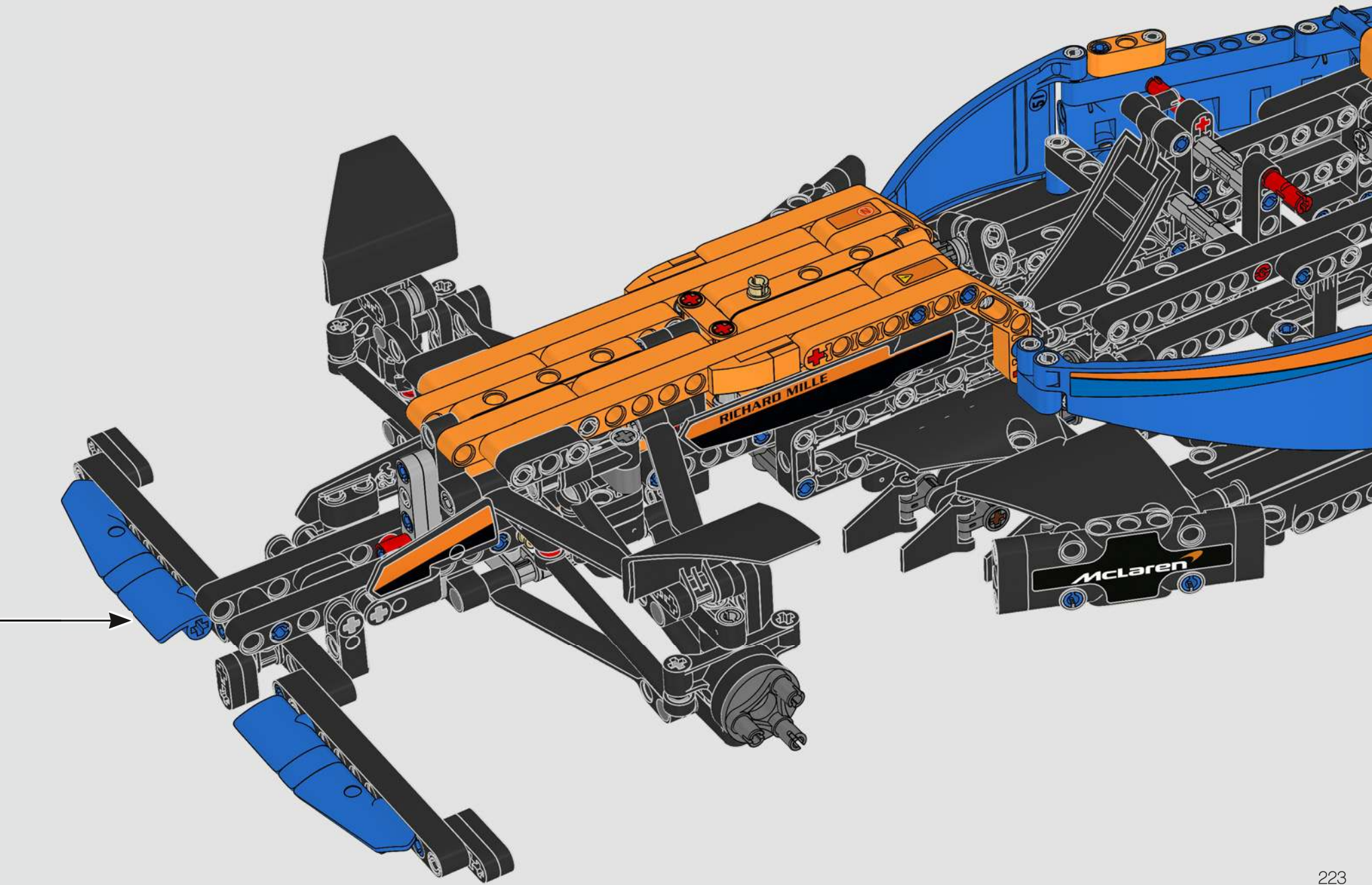

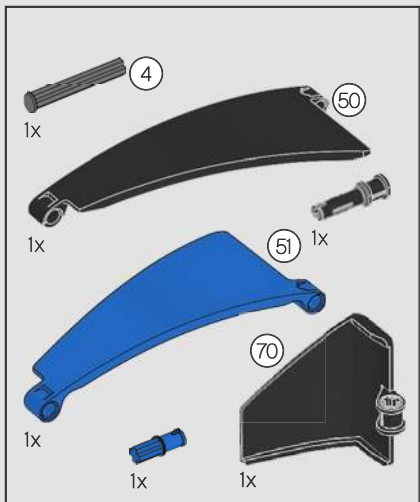

230

1

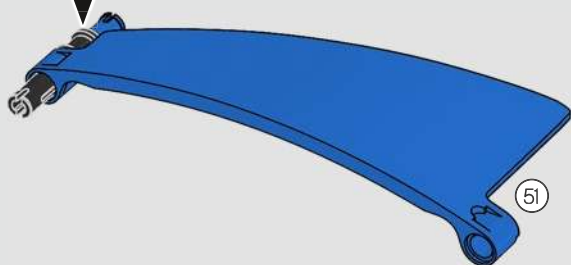
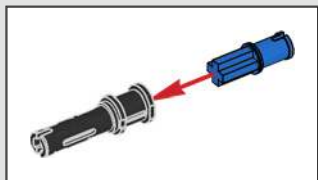

2

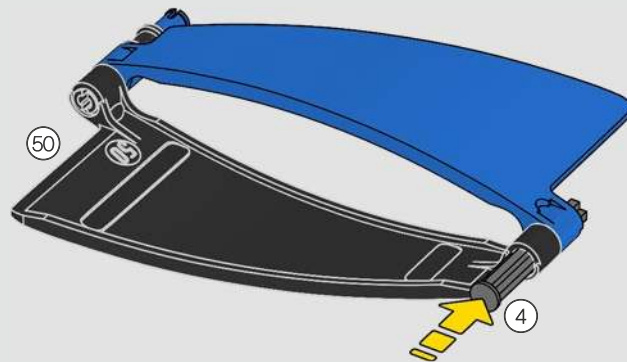

3

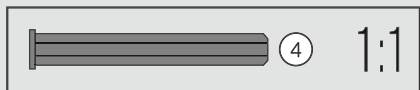
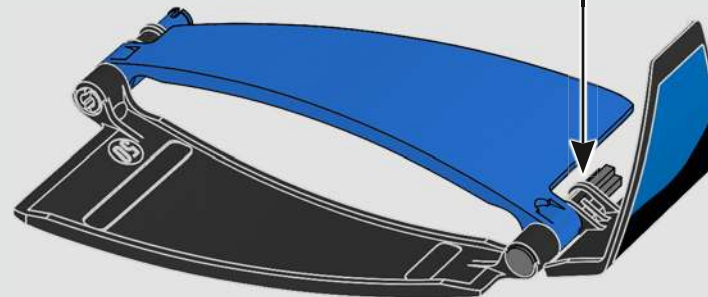
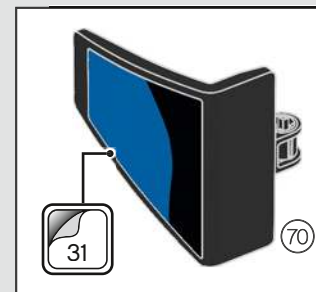

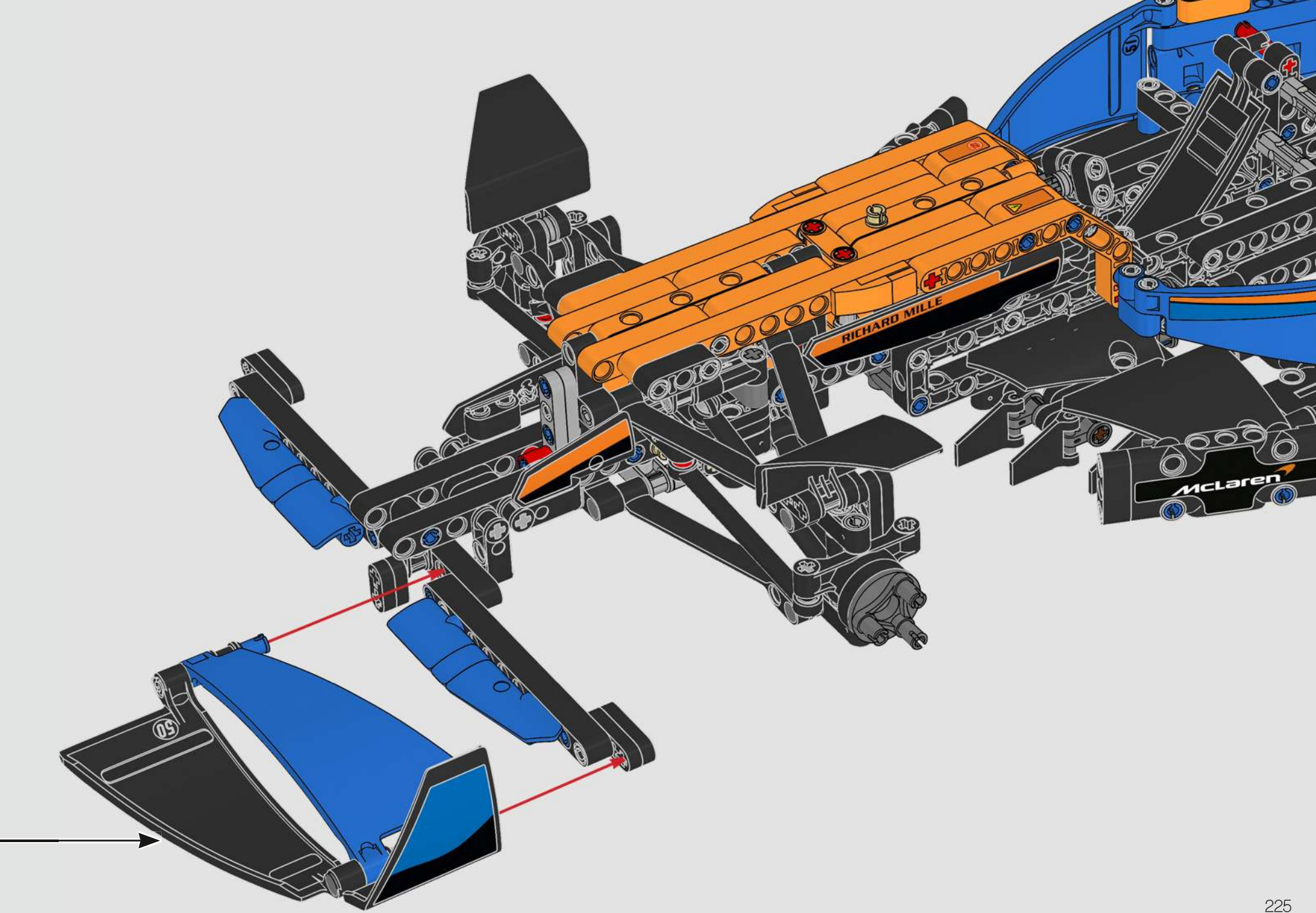

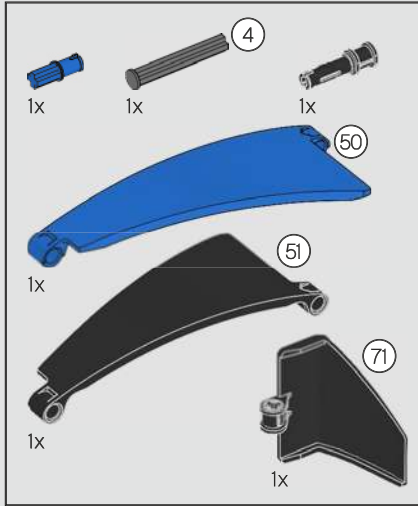

231

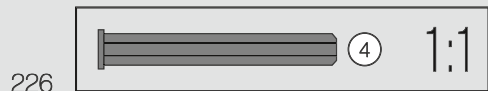
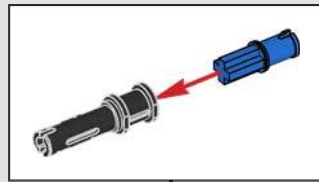
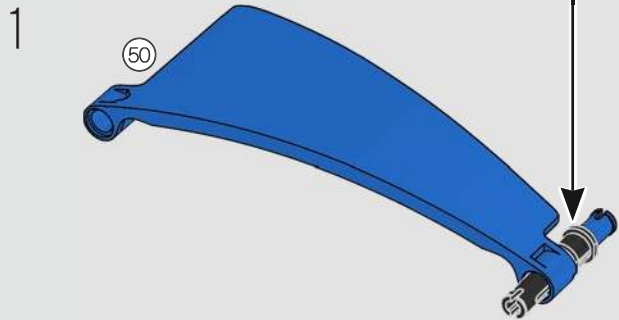

2

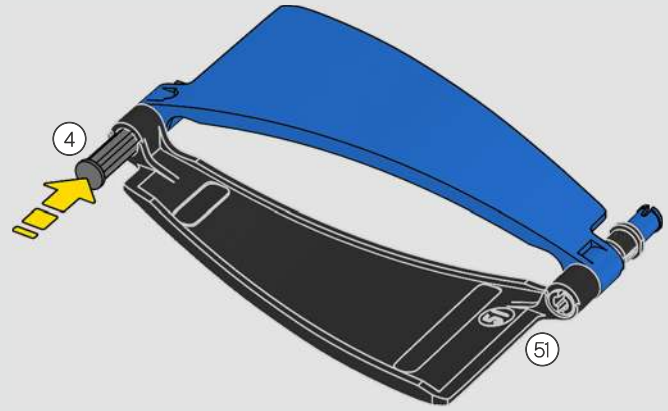

3

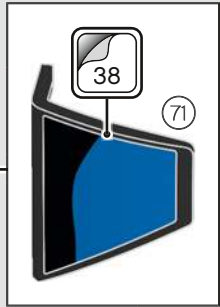
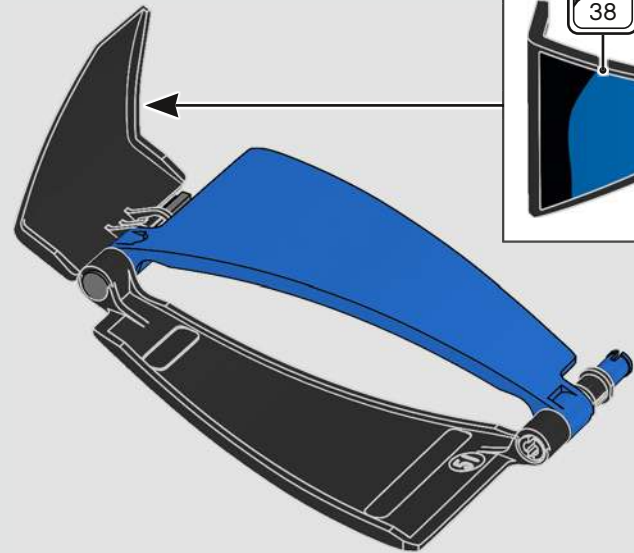

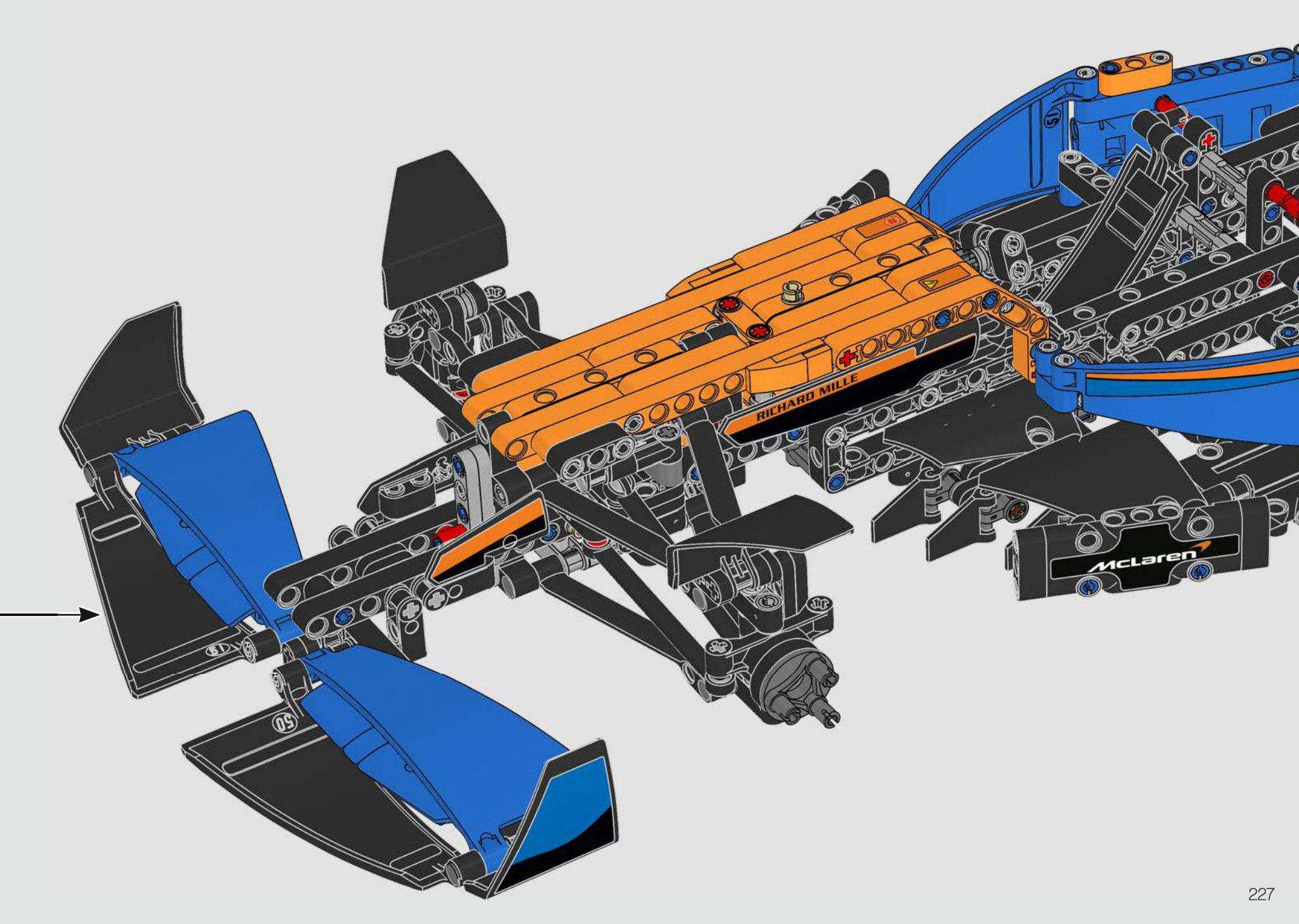

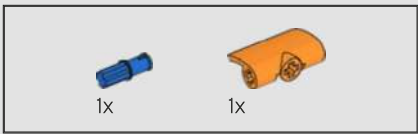

232

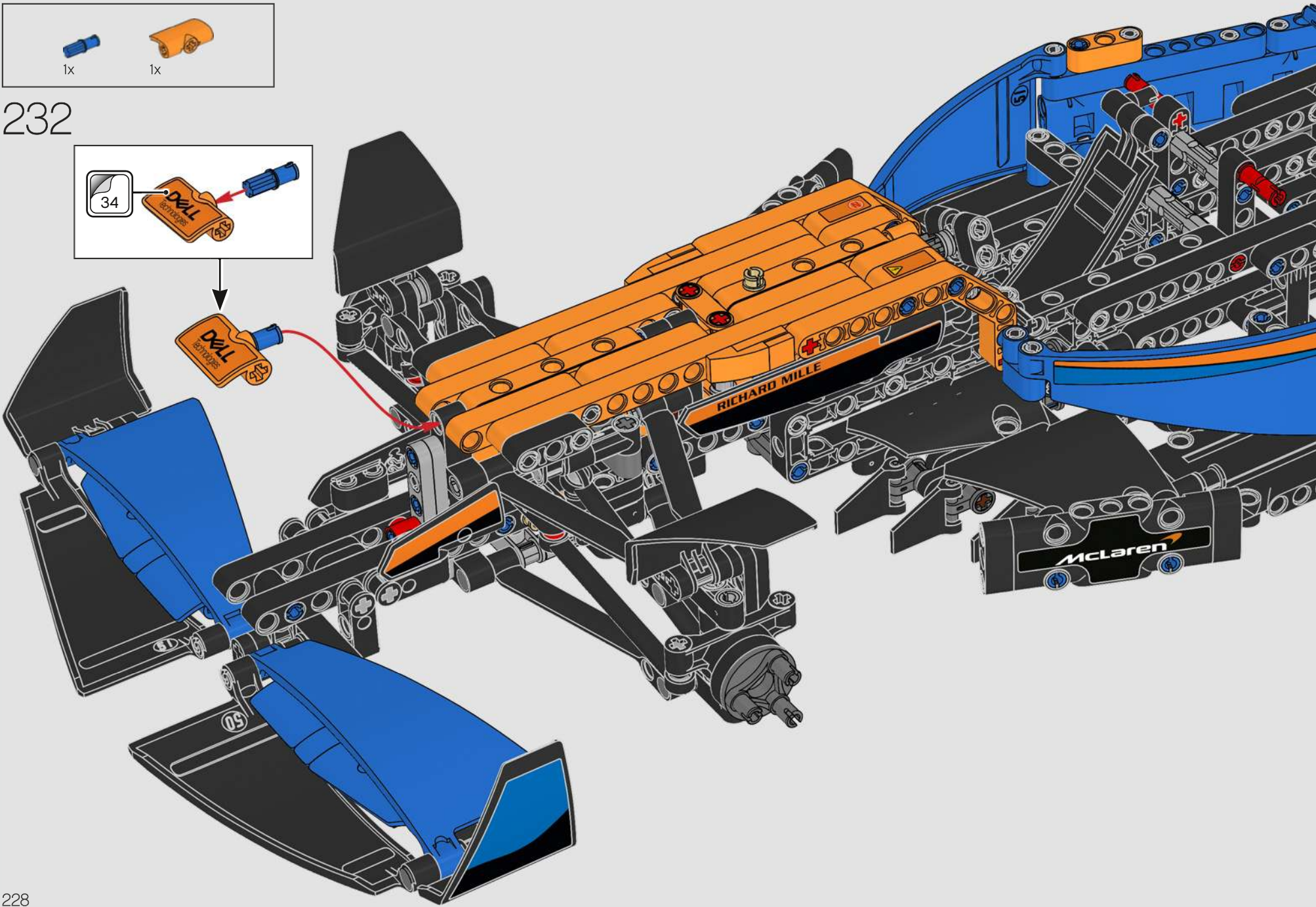
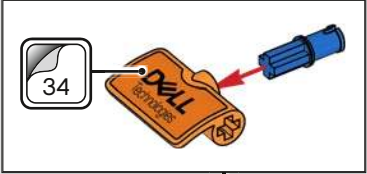

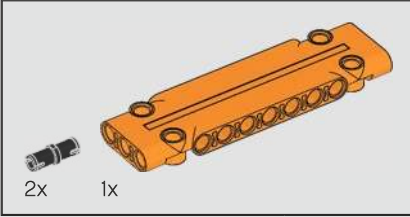
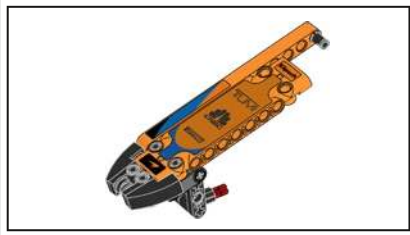

2x 1x

233

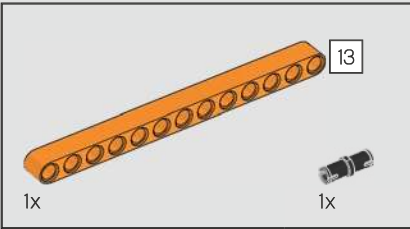
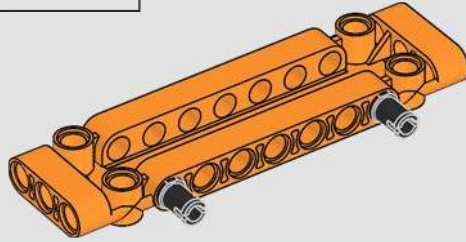

1x

1x

13

234

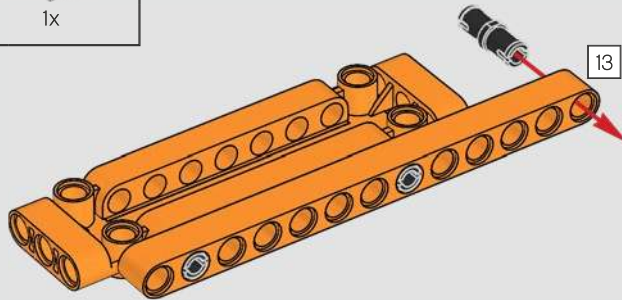

13



2x

235

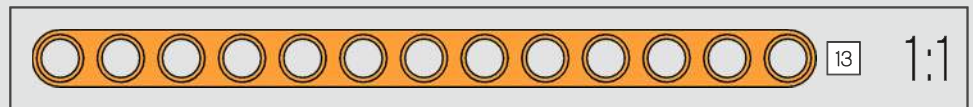
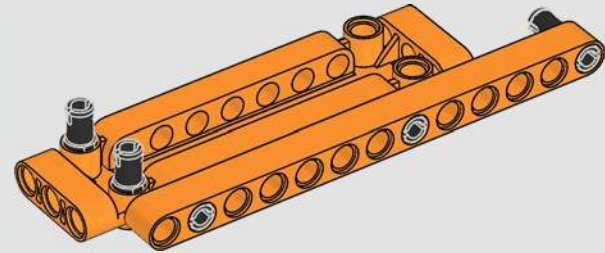

13

1:1

241

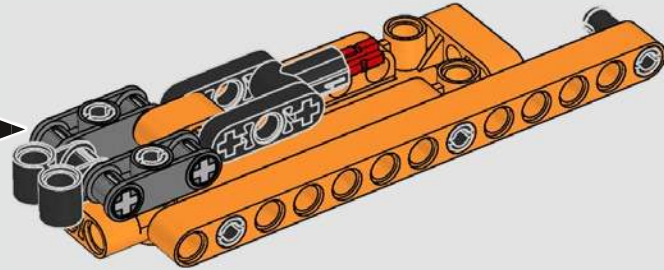

242

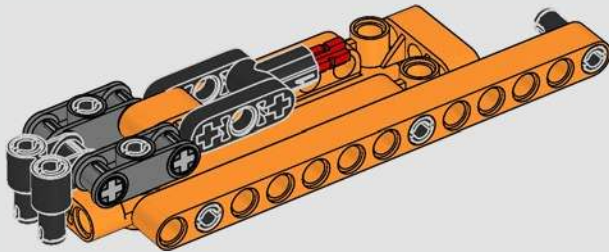

243

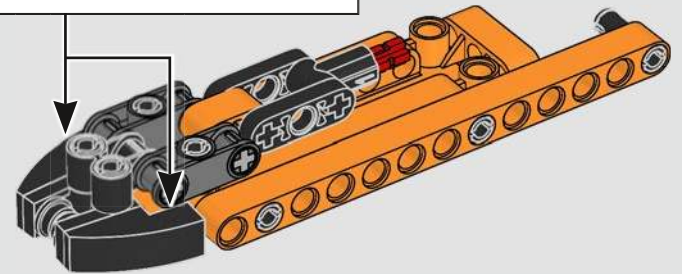
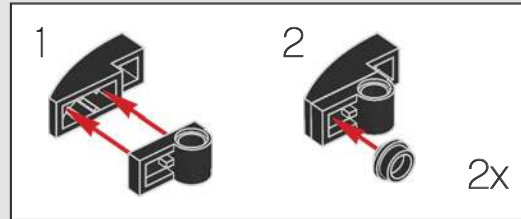

244

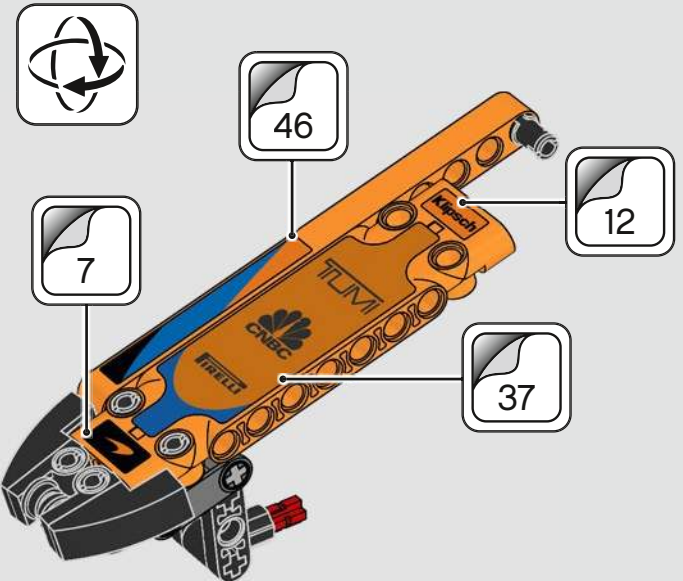

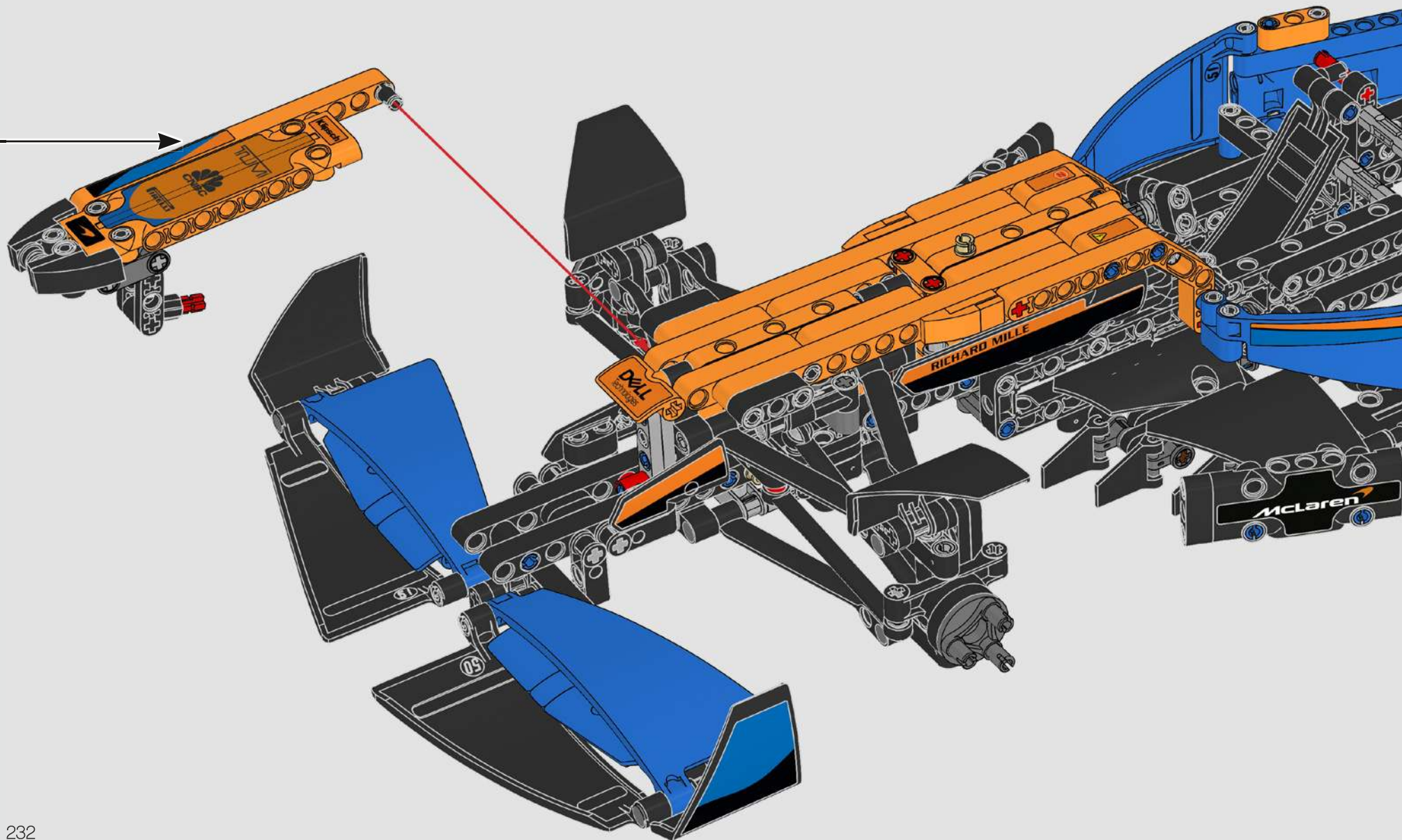

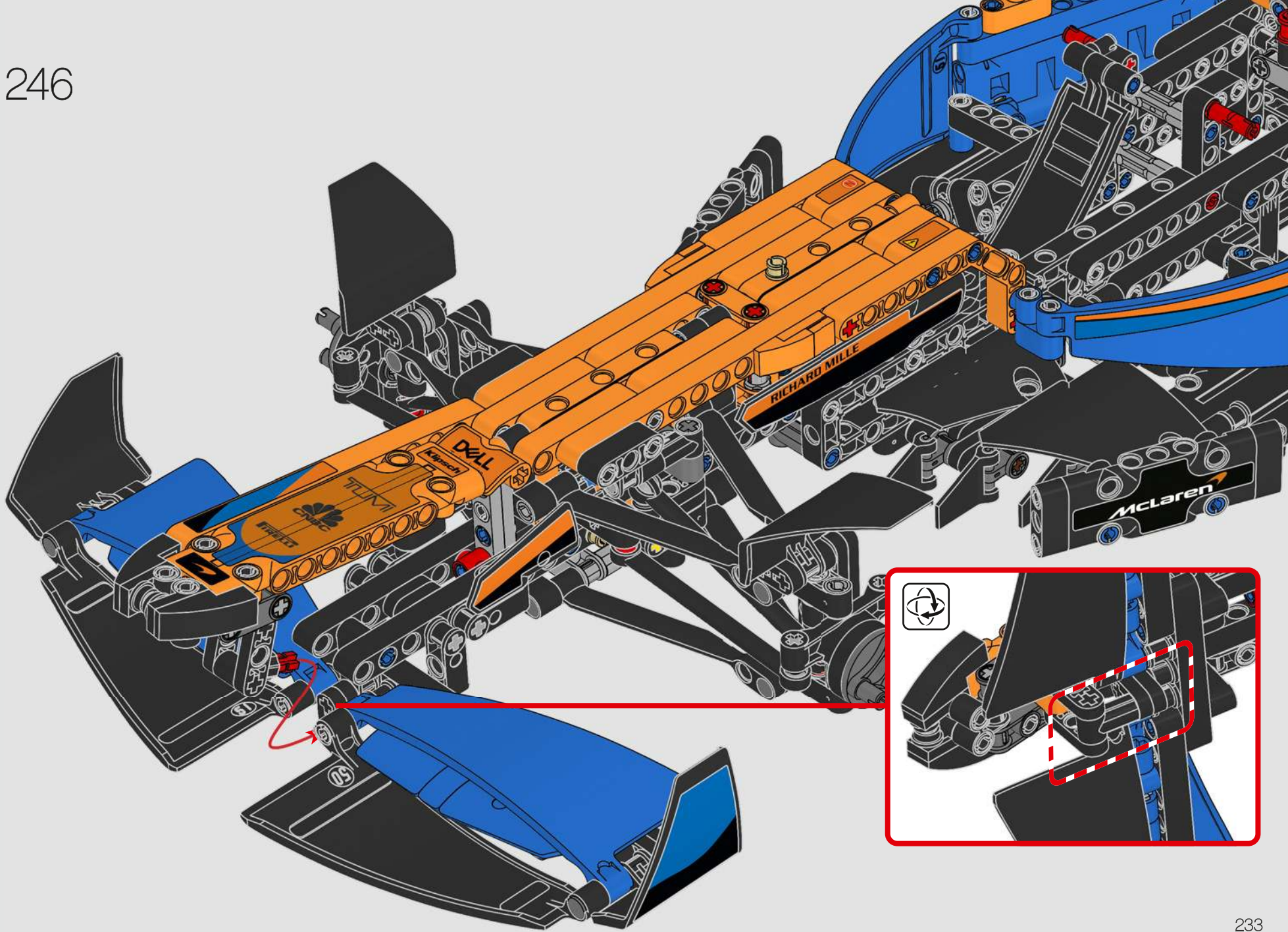

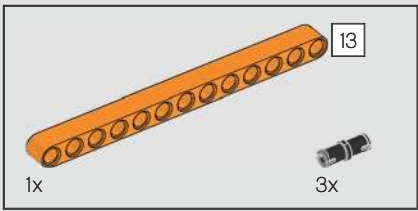

247

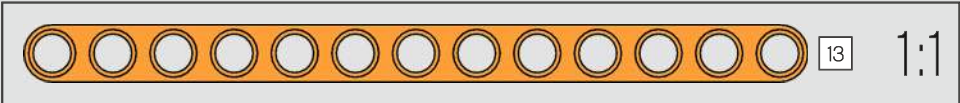
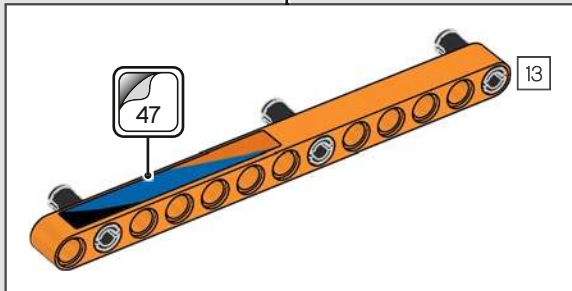
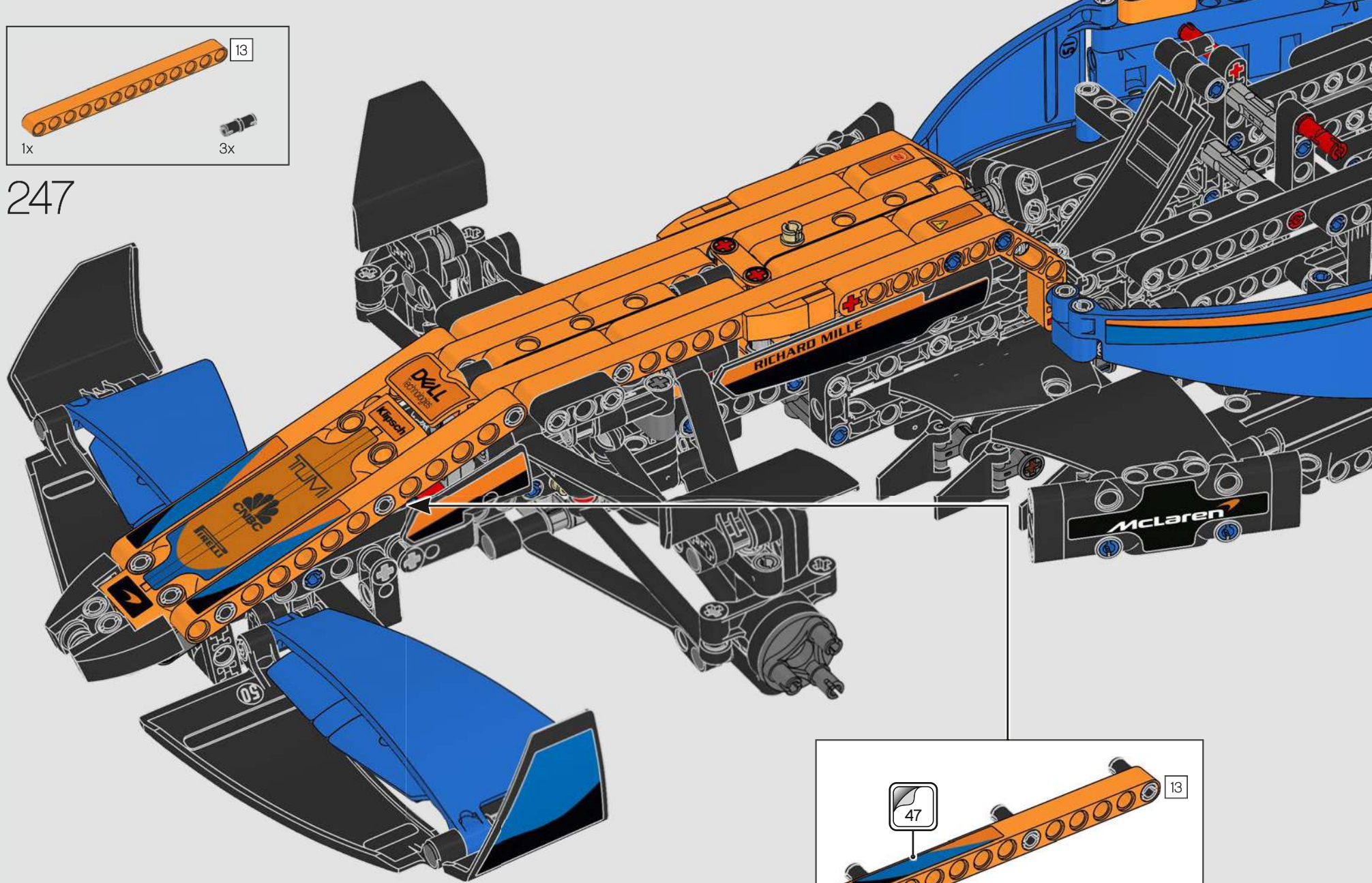

234

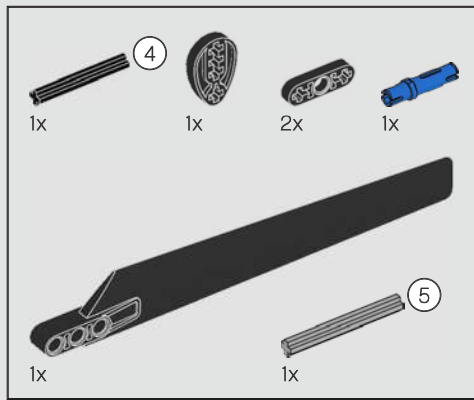

248

1

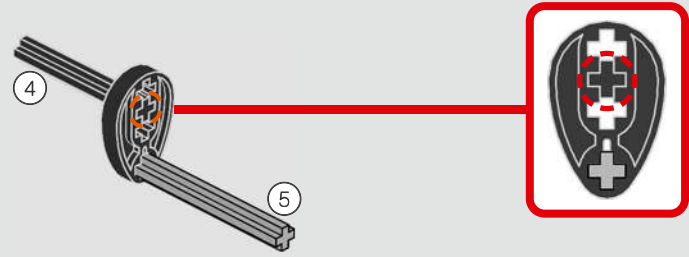

2

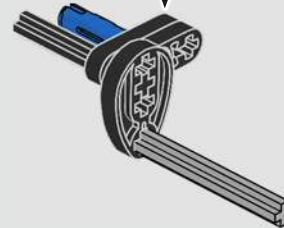
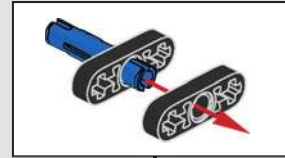

3

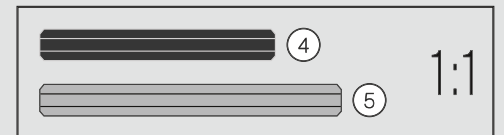
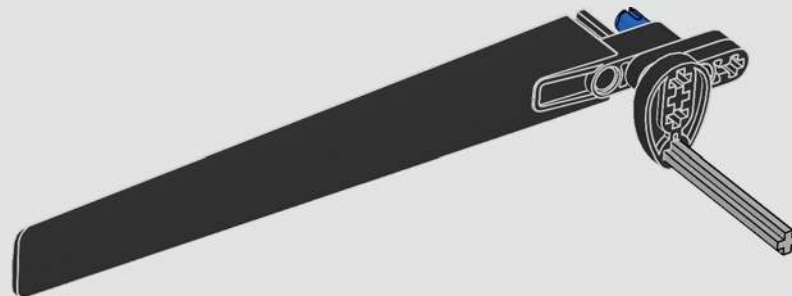

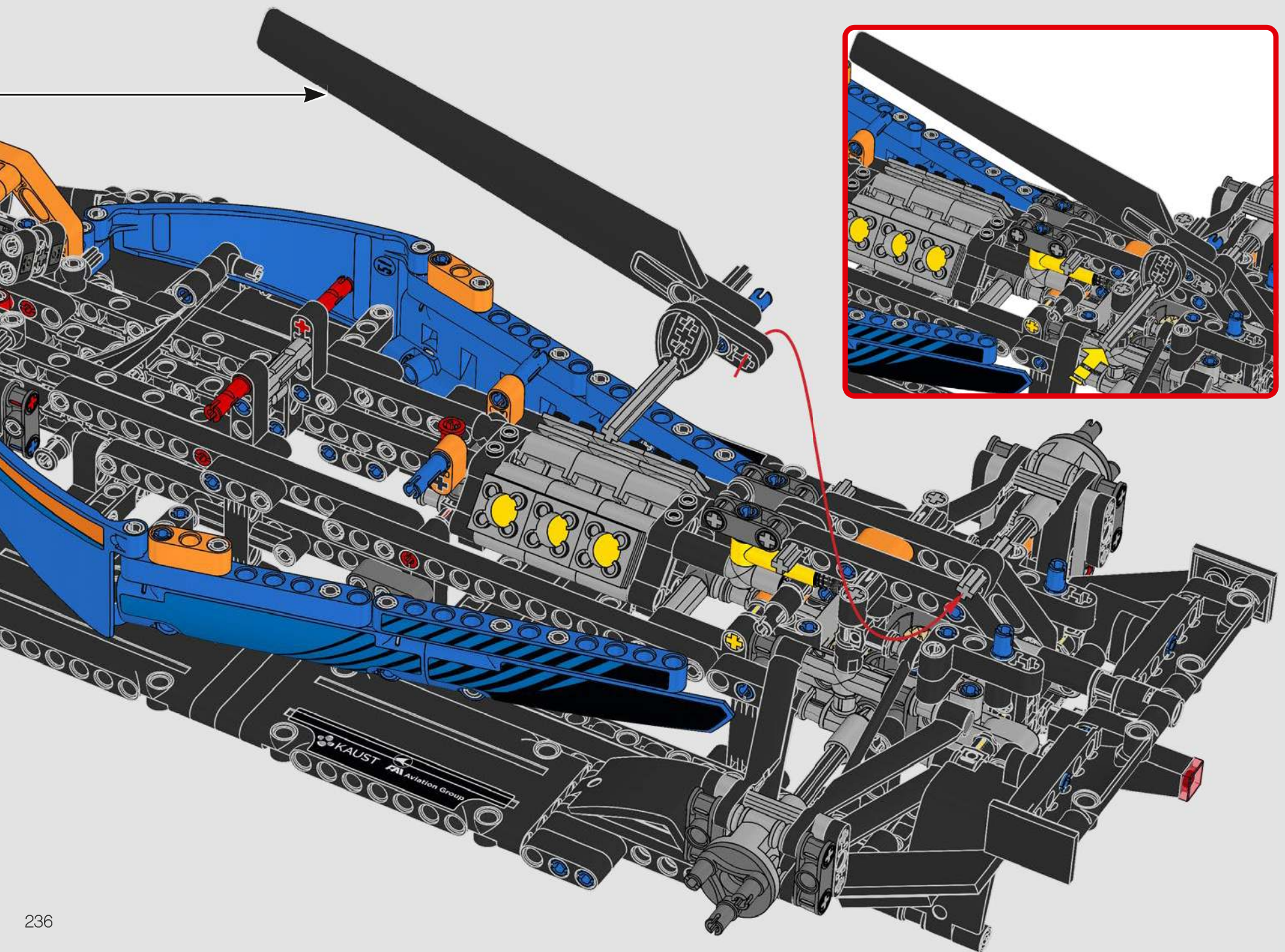



249

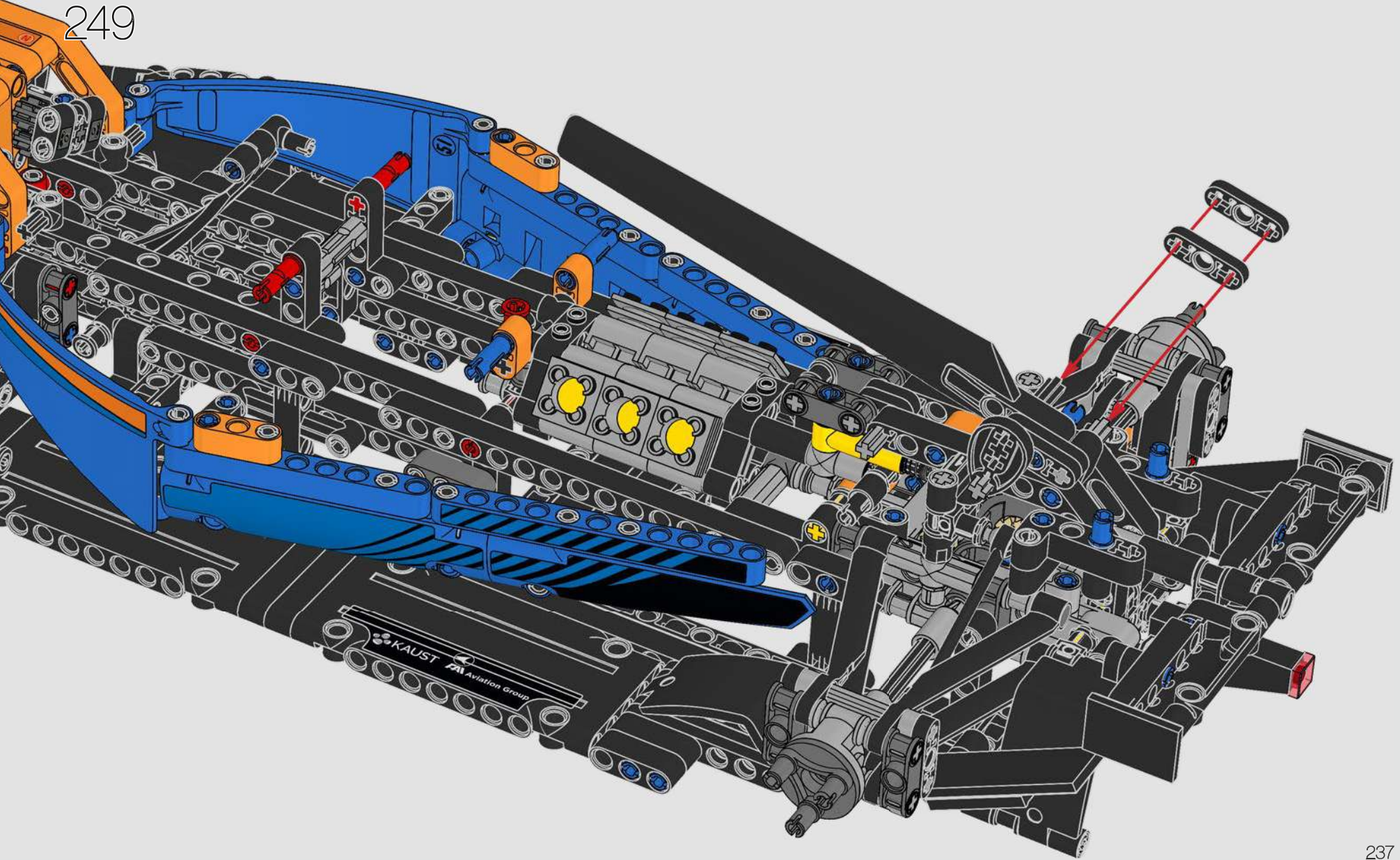



1x

250

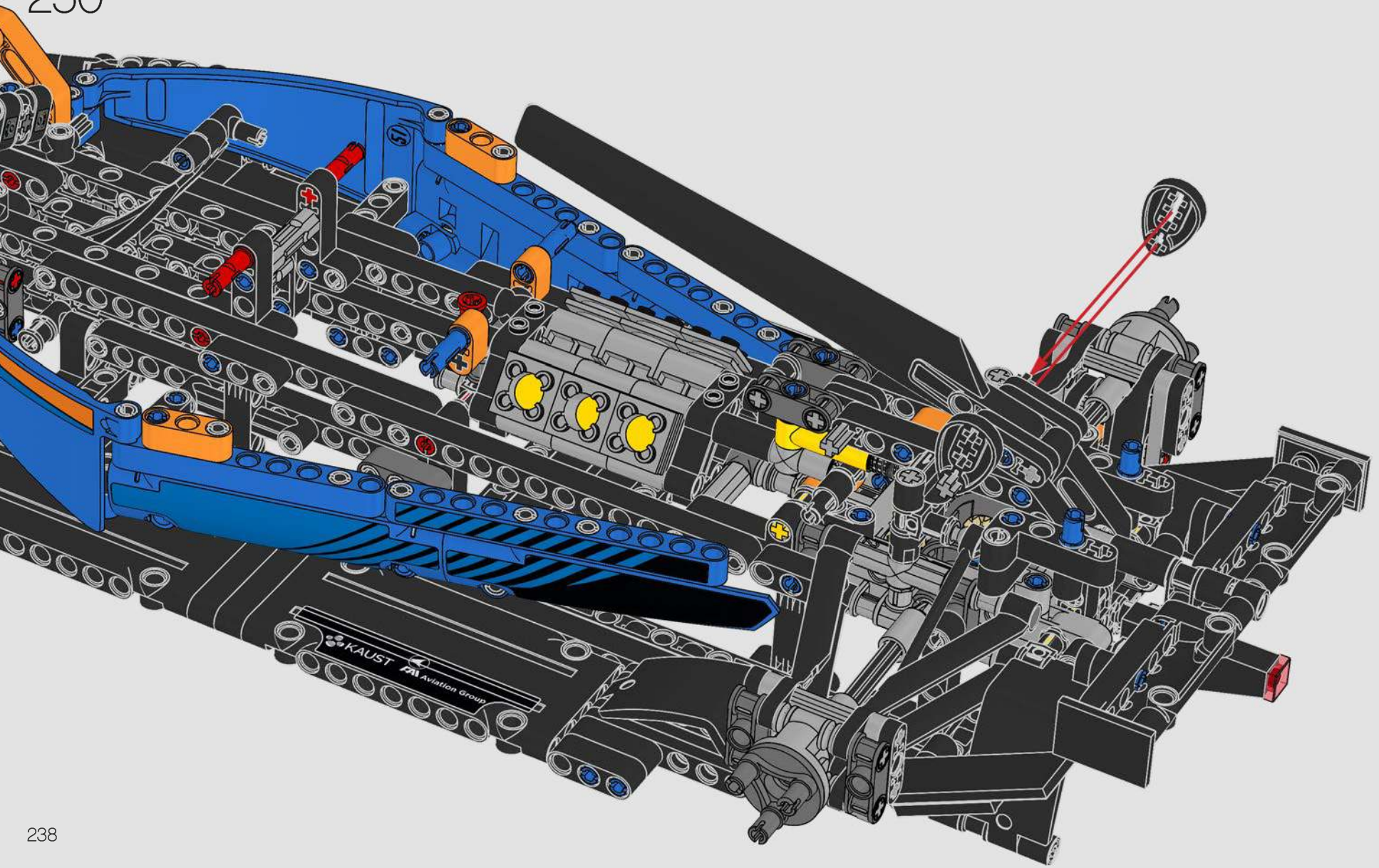

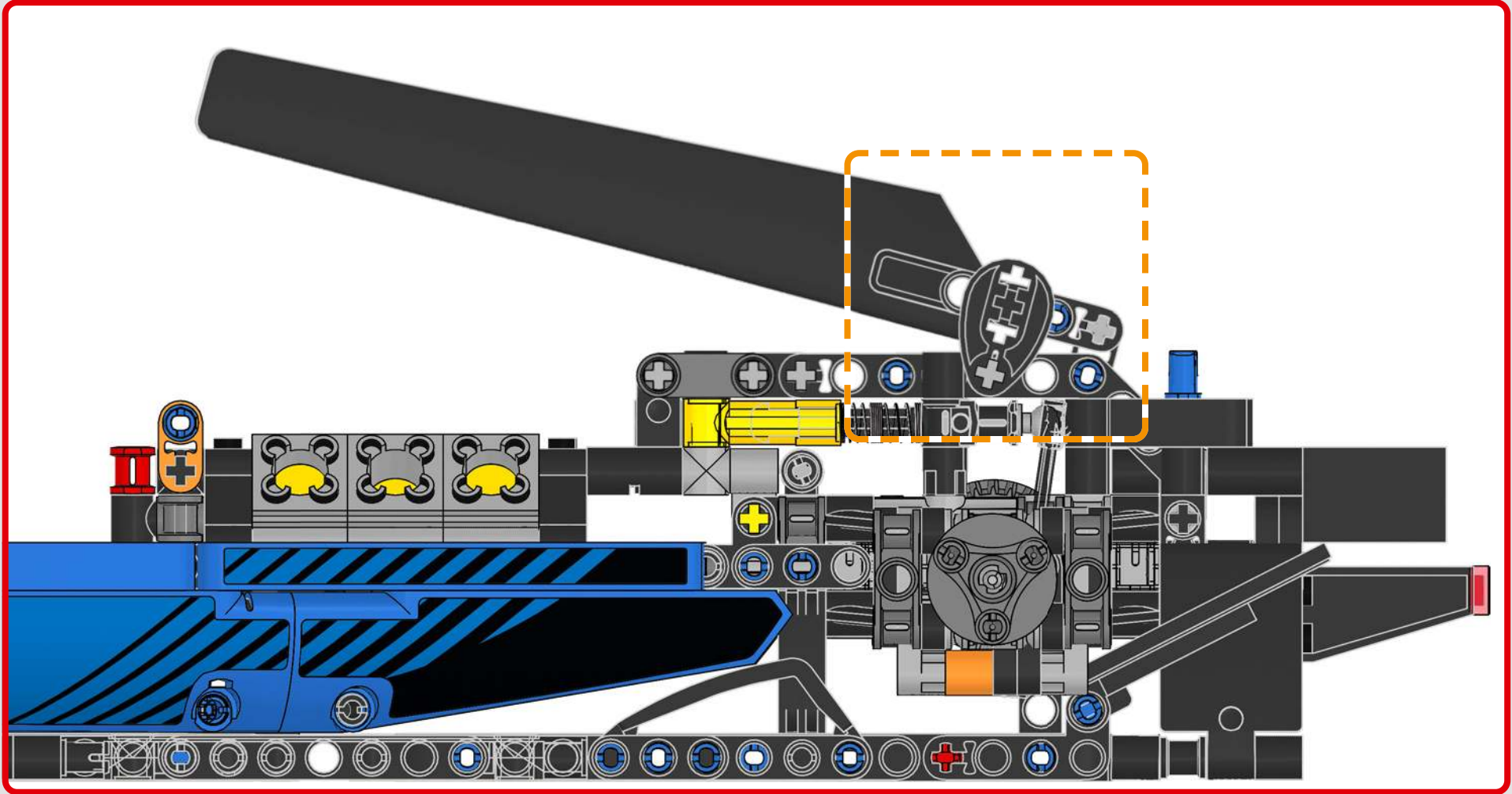

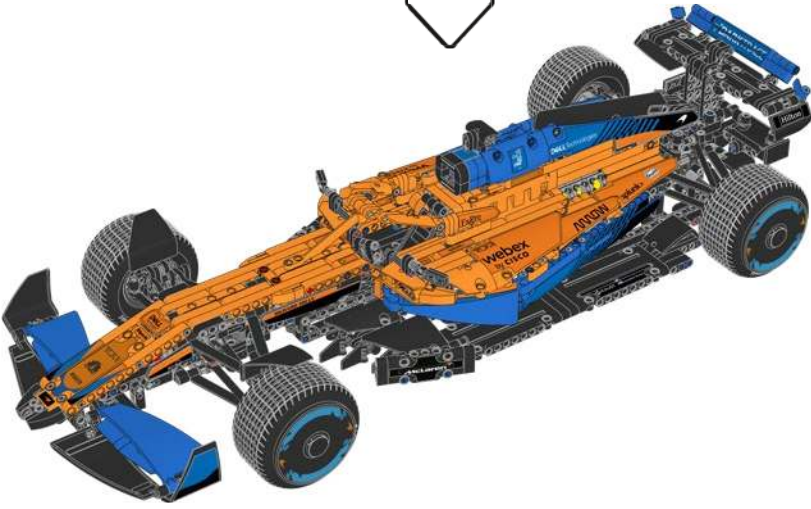
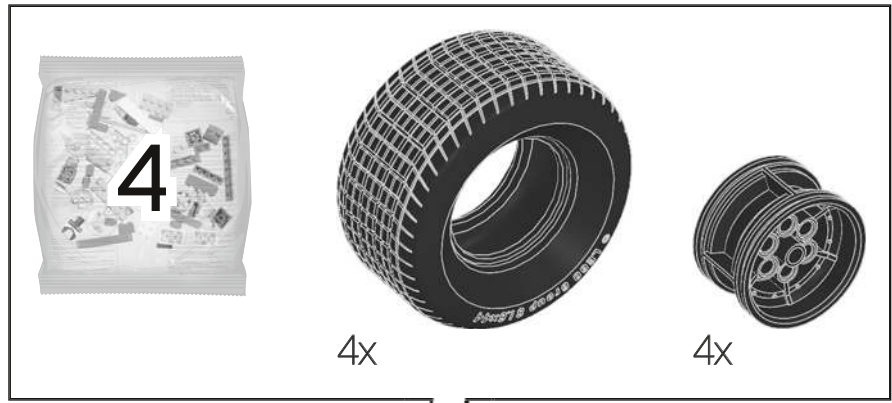

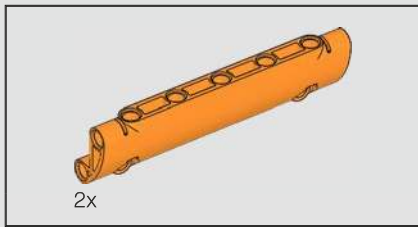

251

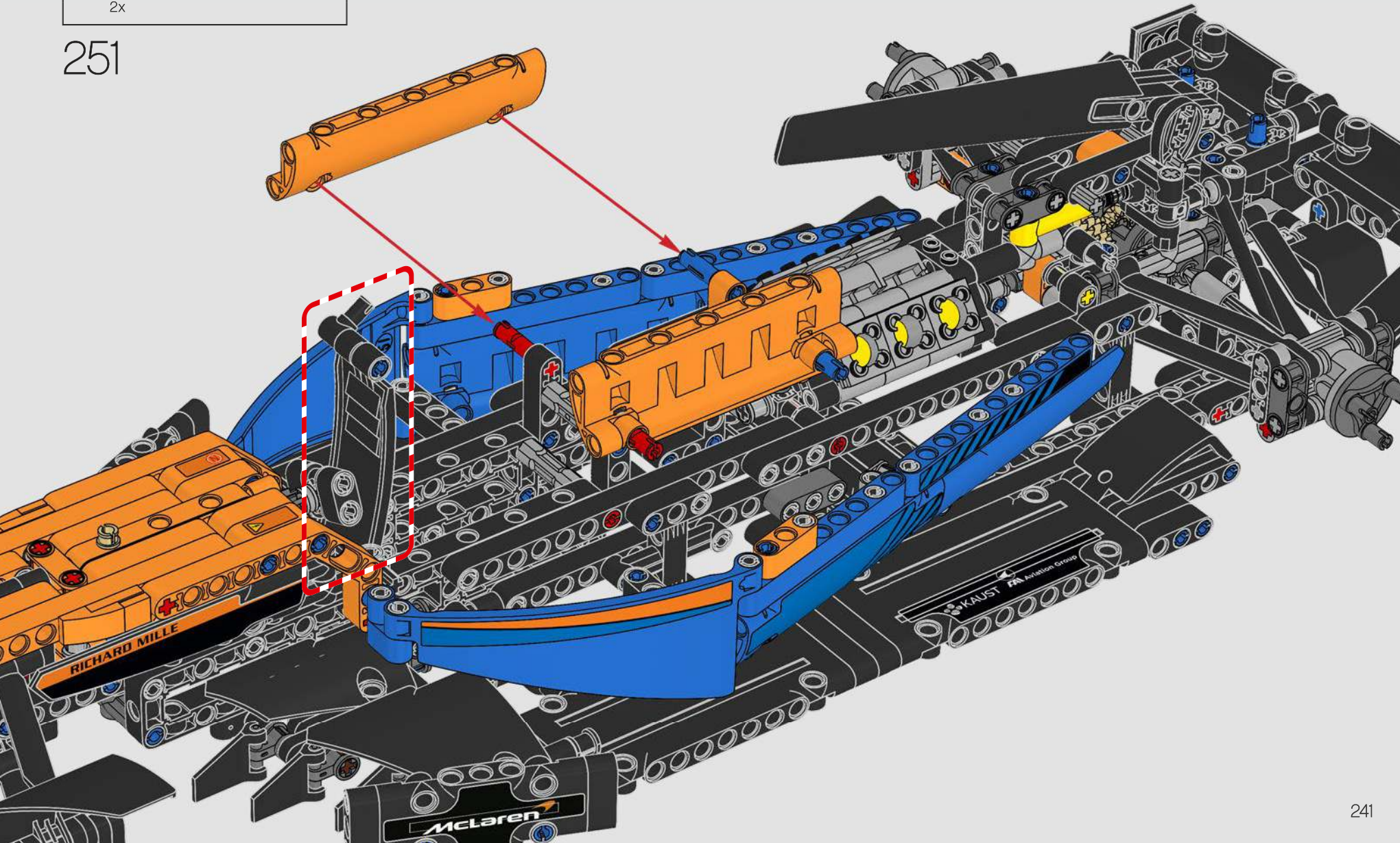

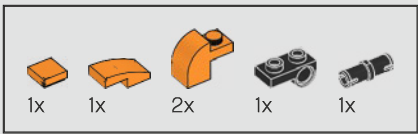

252

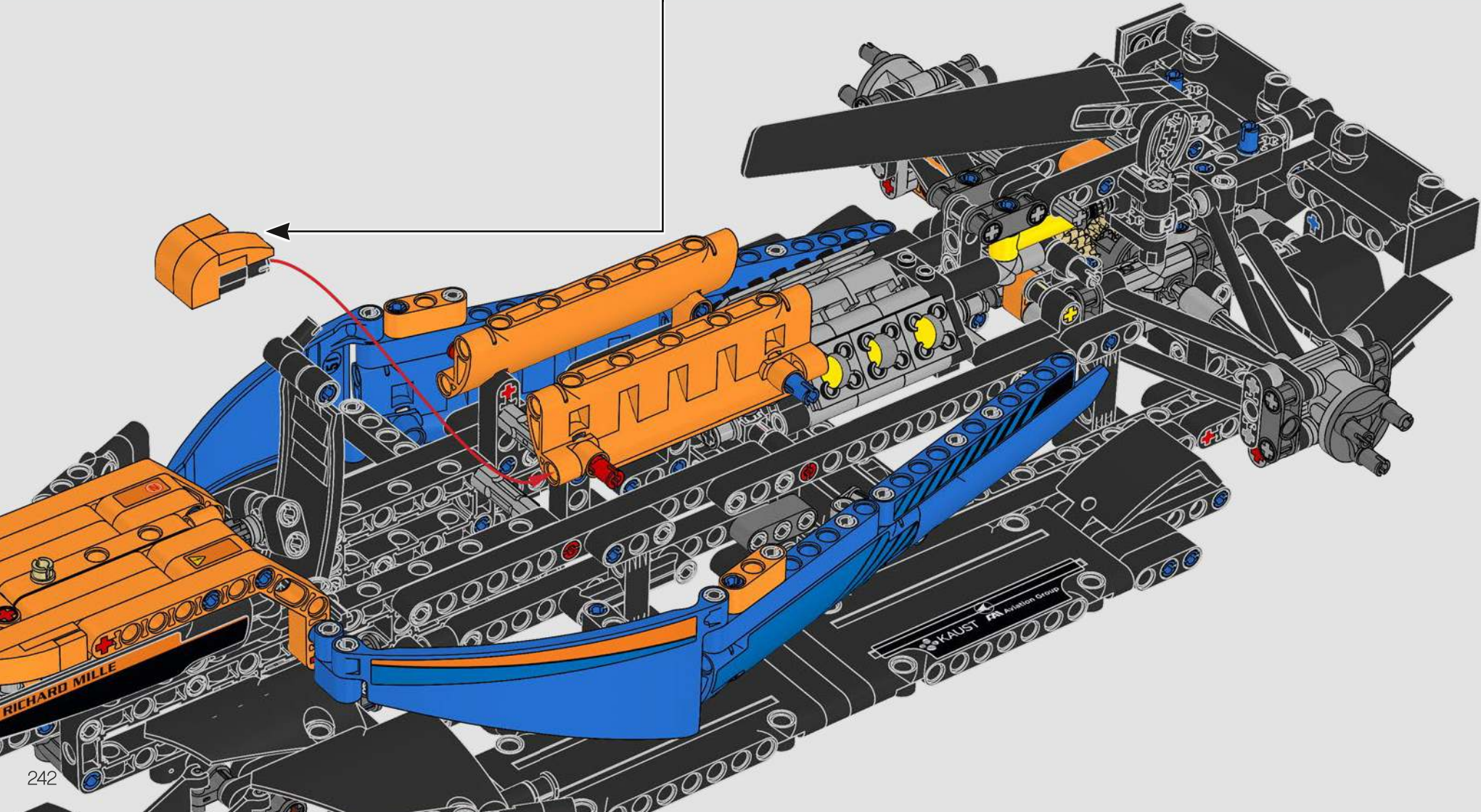
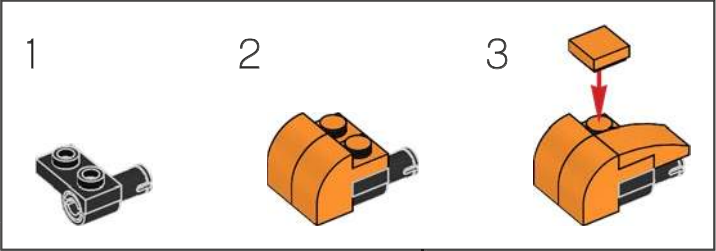

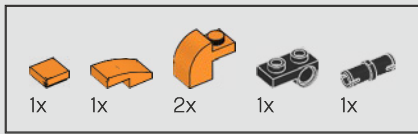

253

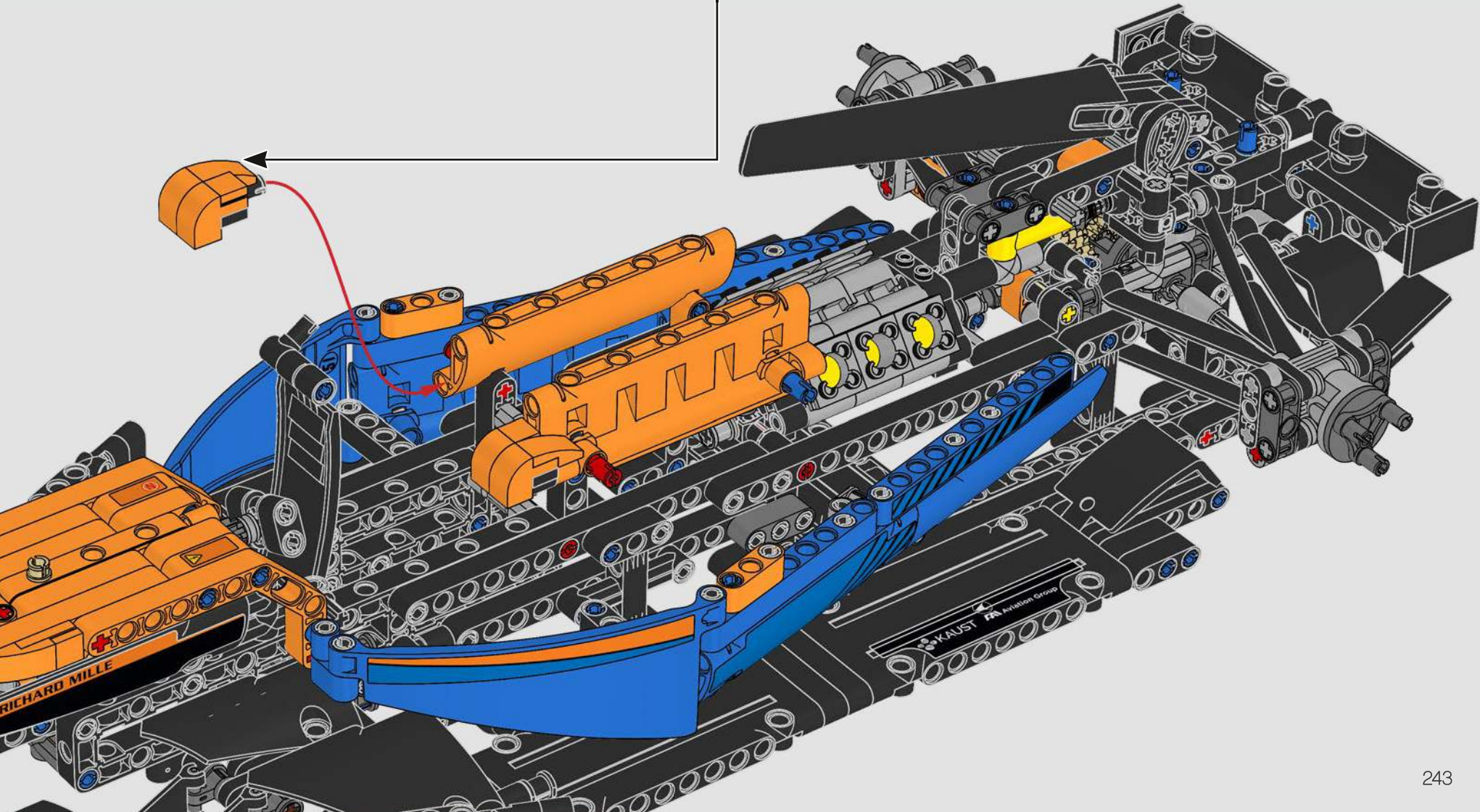
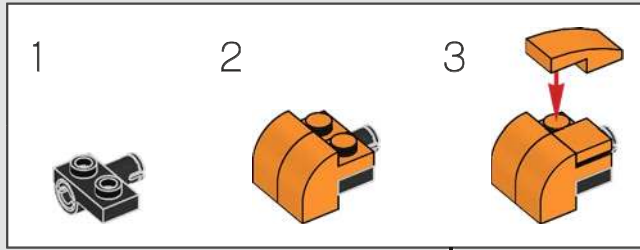

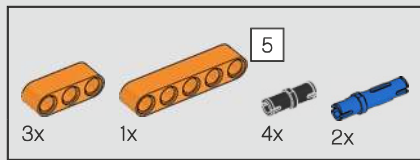

254

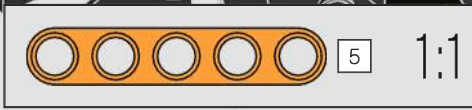
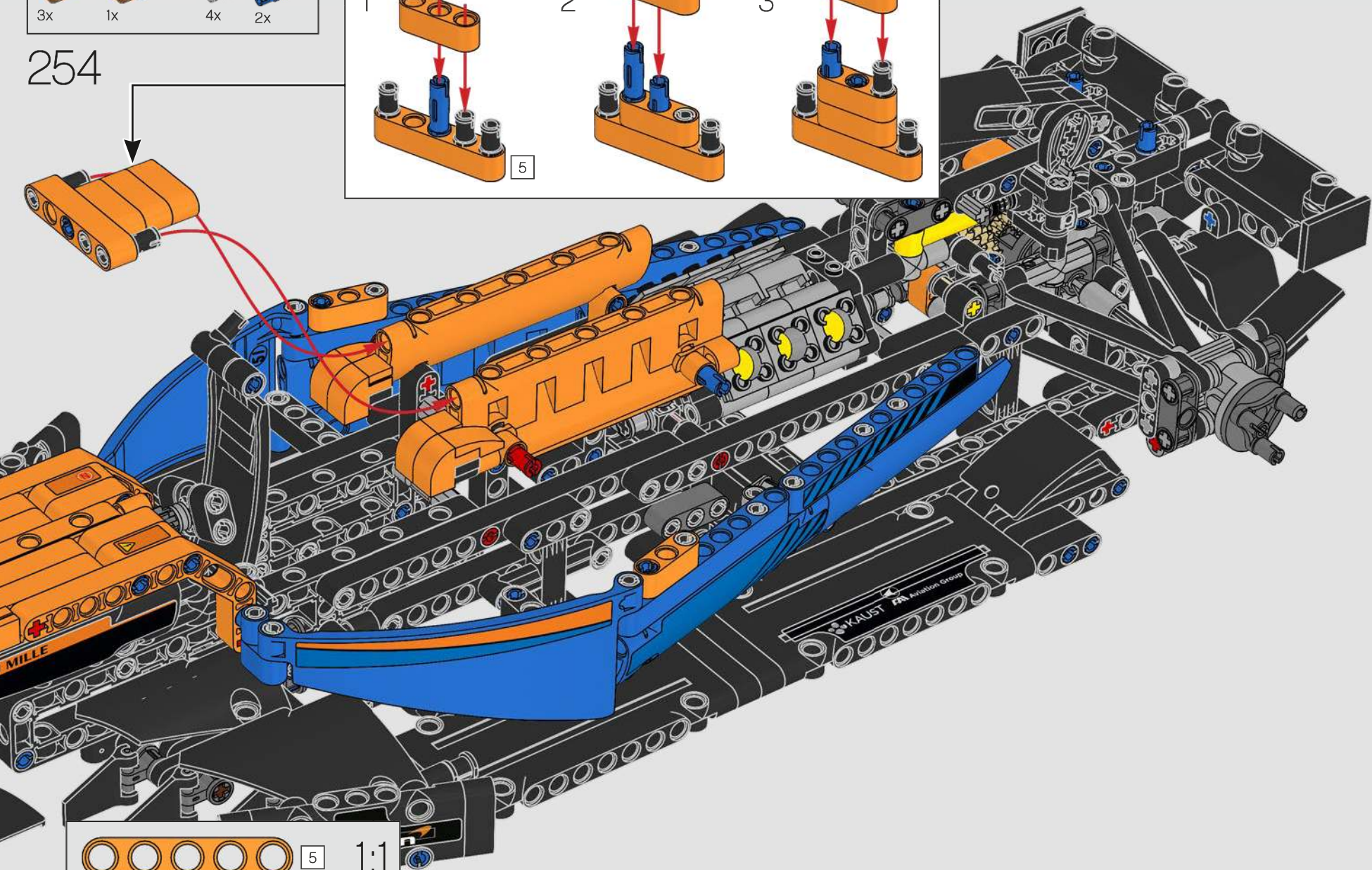
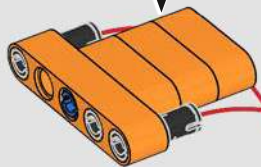
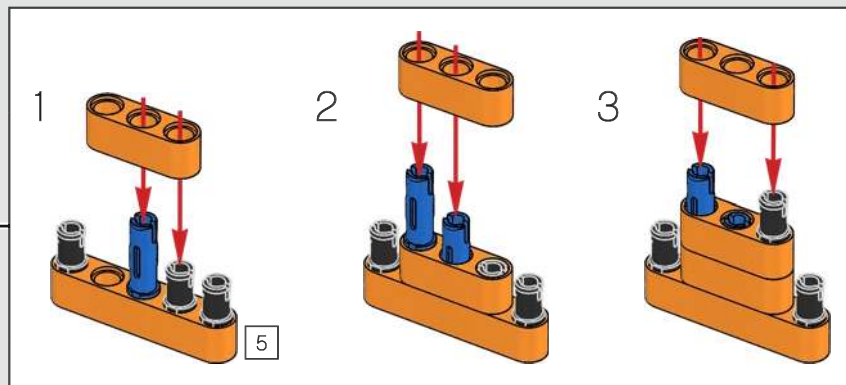

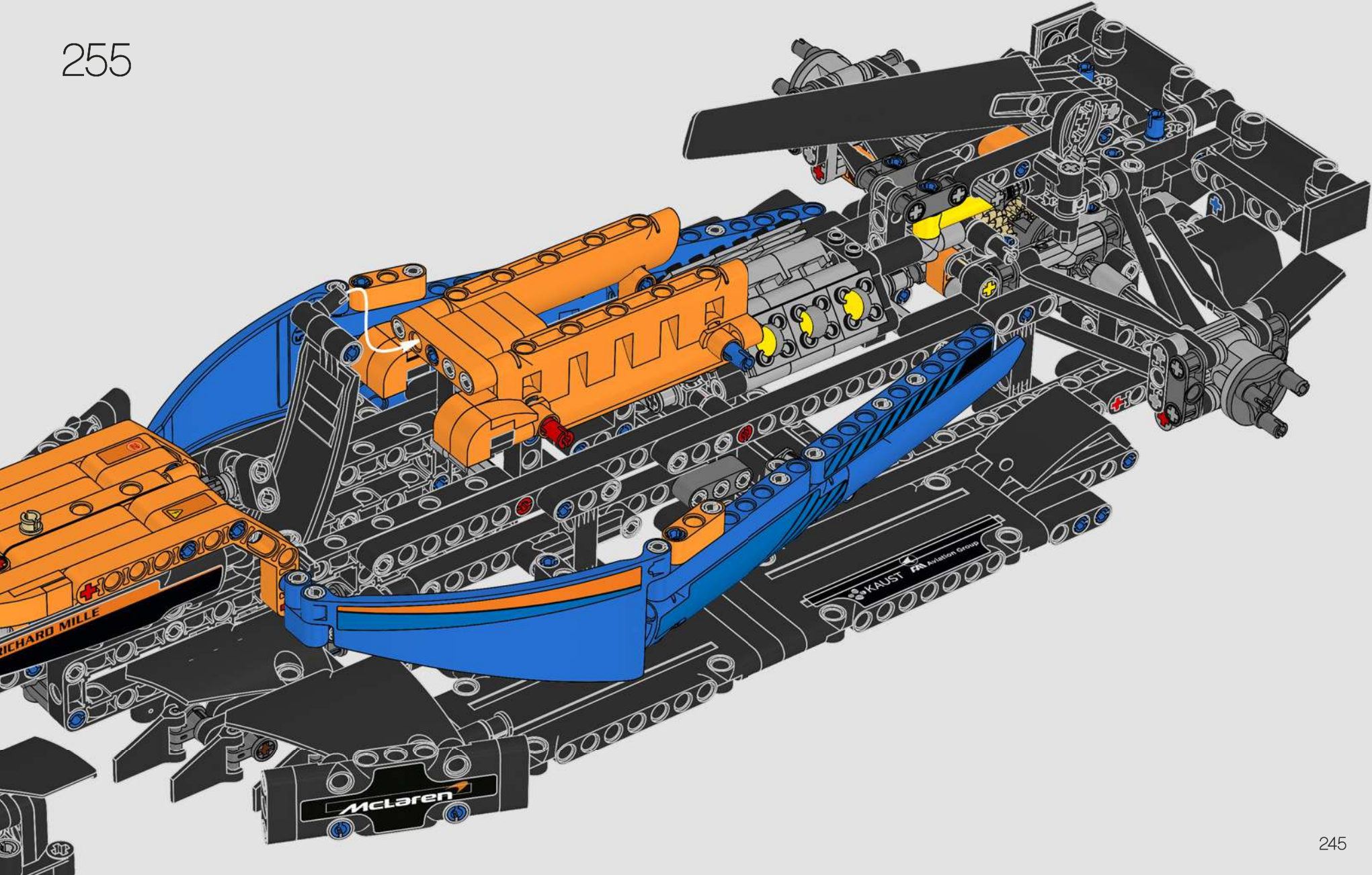

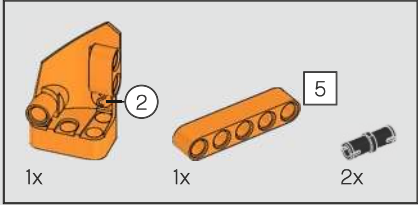
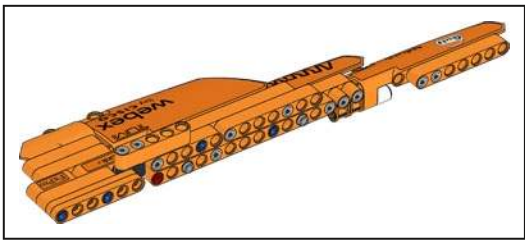

256

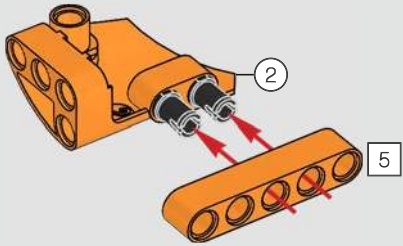

246

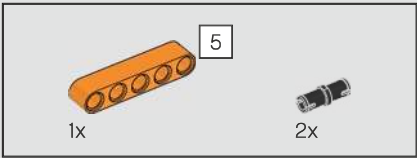
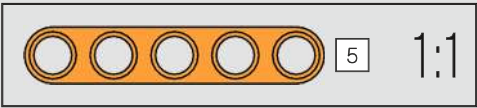

257

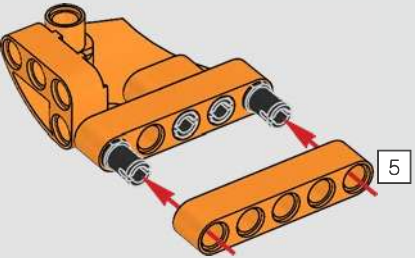

258

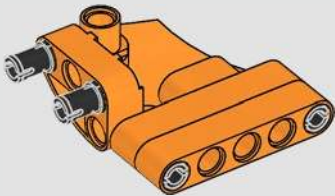

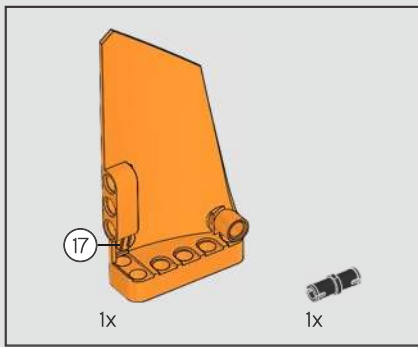

259

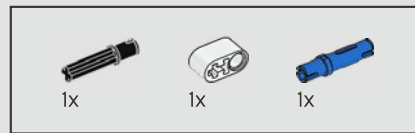
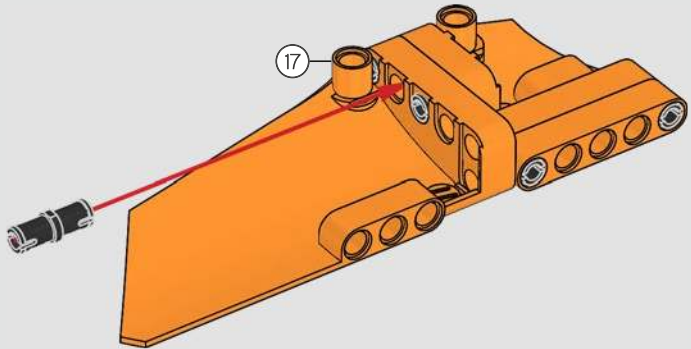

260

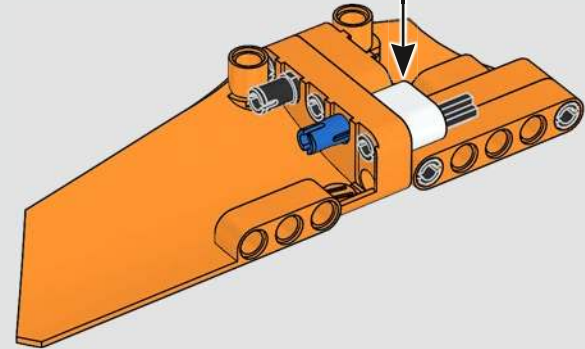
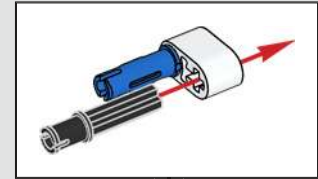

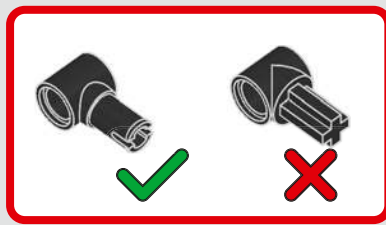
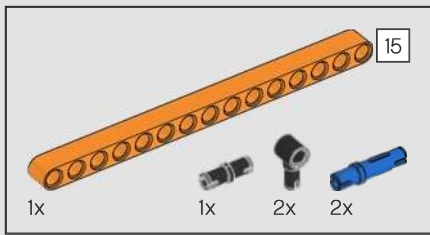

261

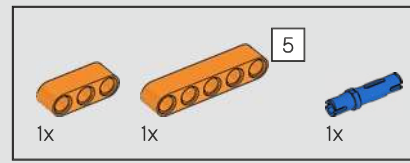
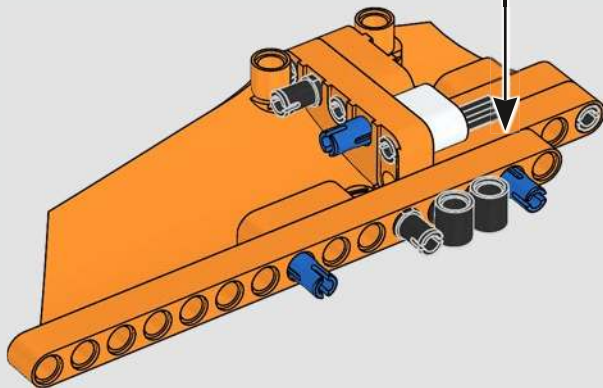
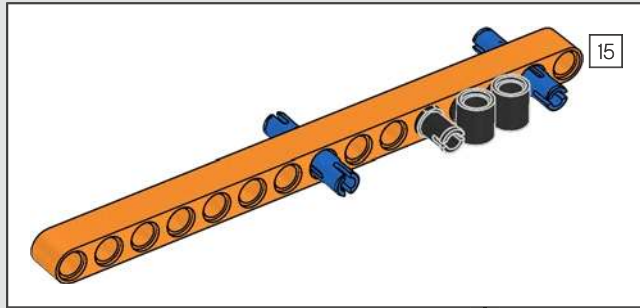

262

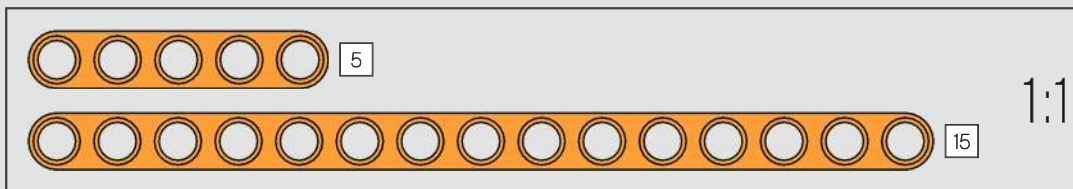
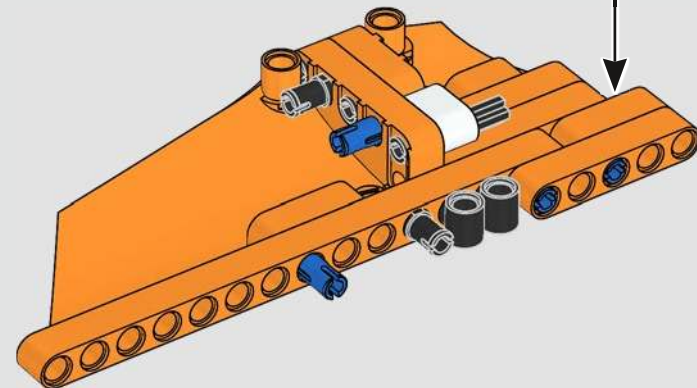
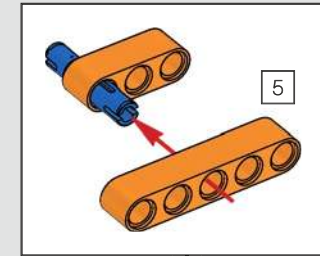

248

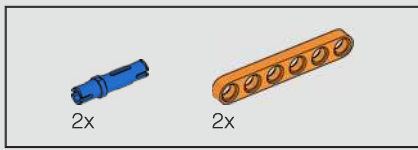

263

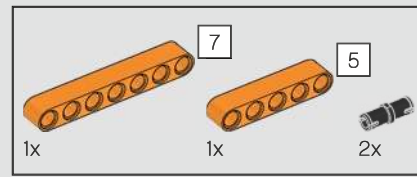
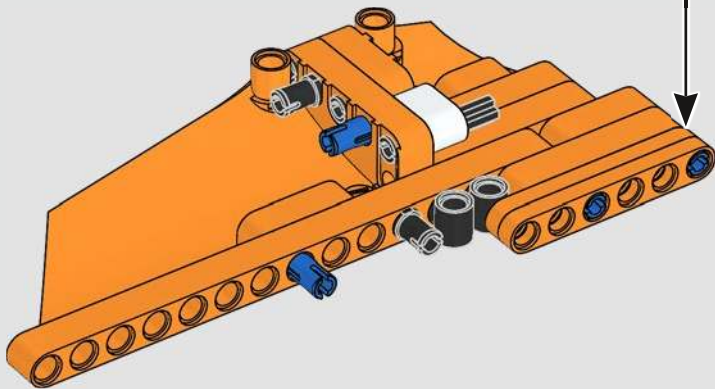
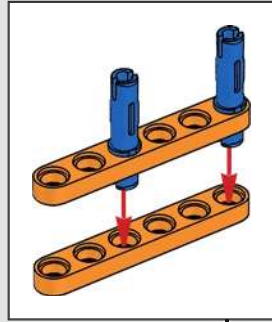

264

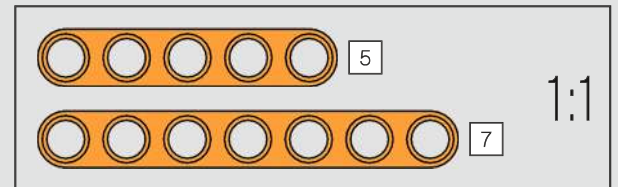
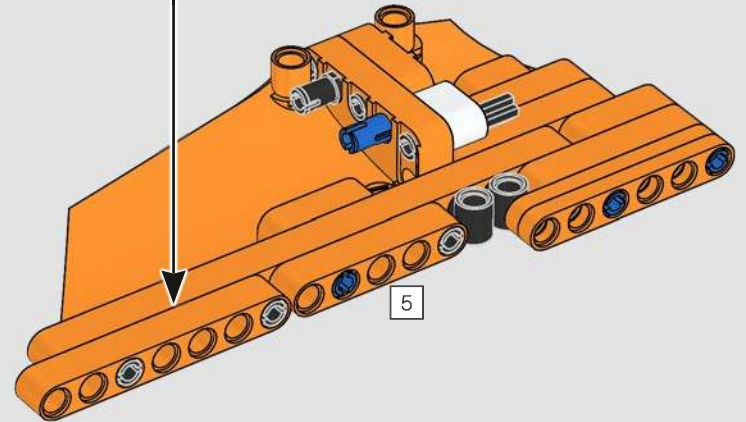
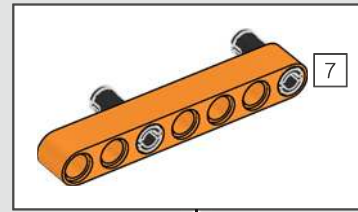

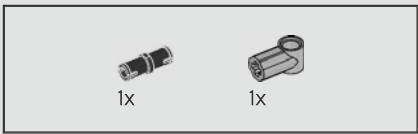

265

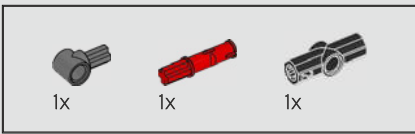
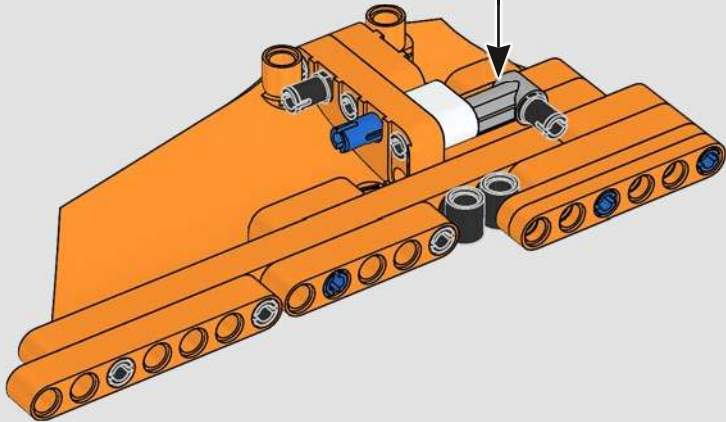

266

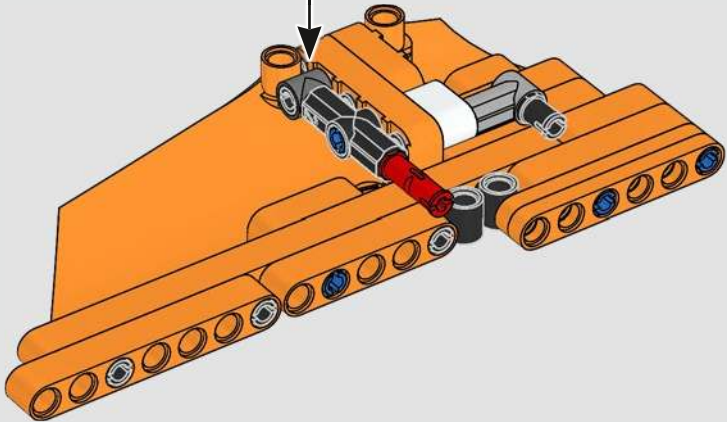
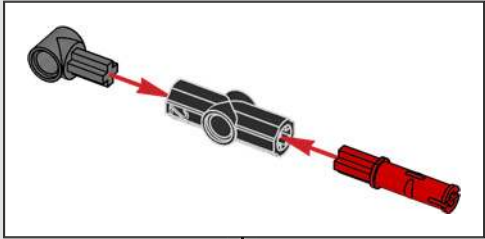

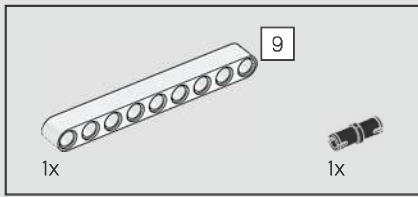

267

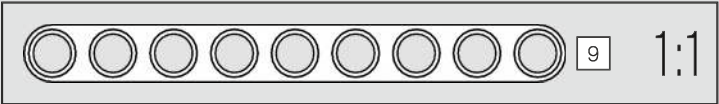
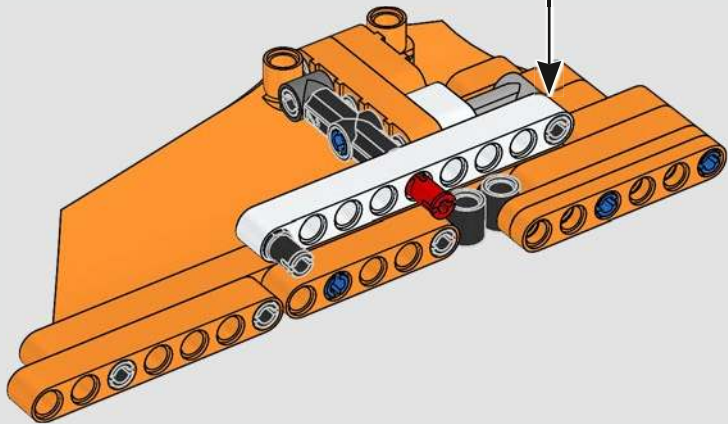
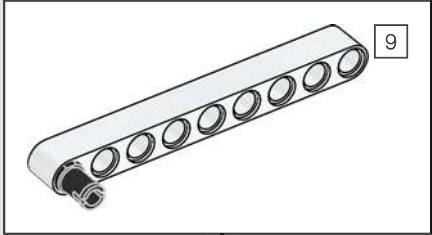

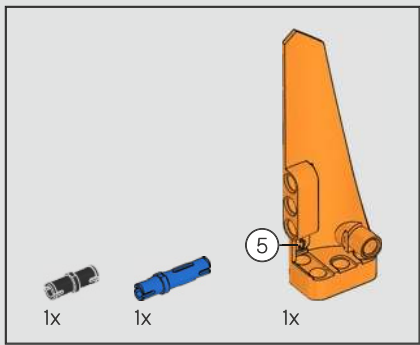

268

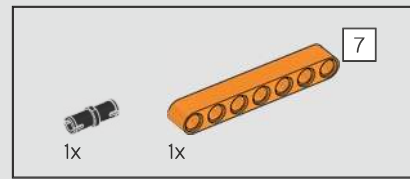
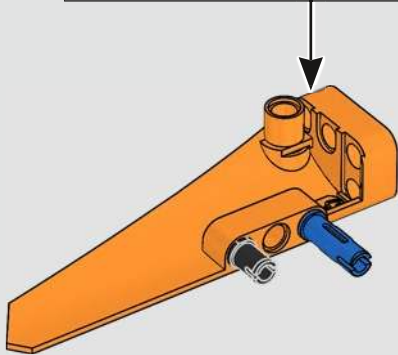
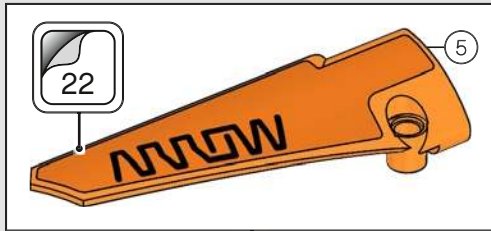

269

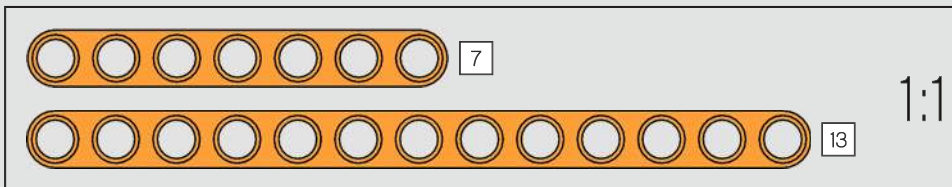
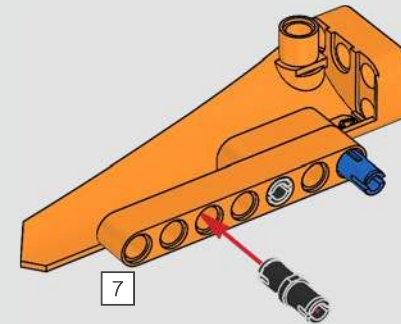

252

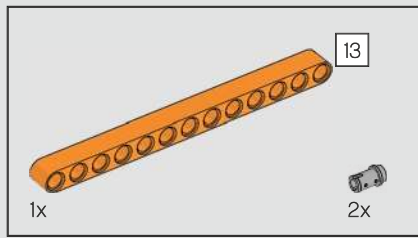

270

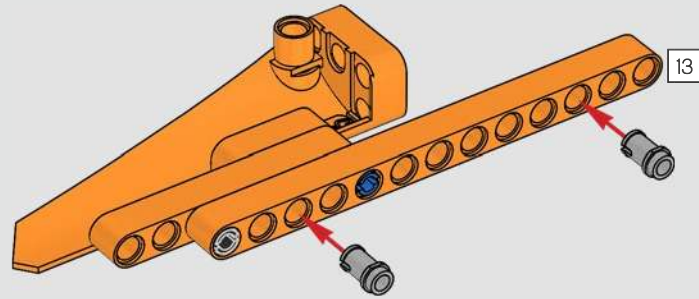

271

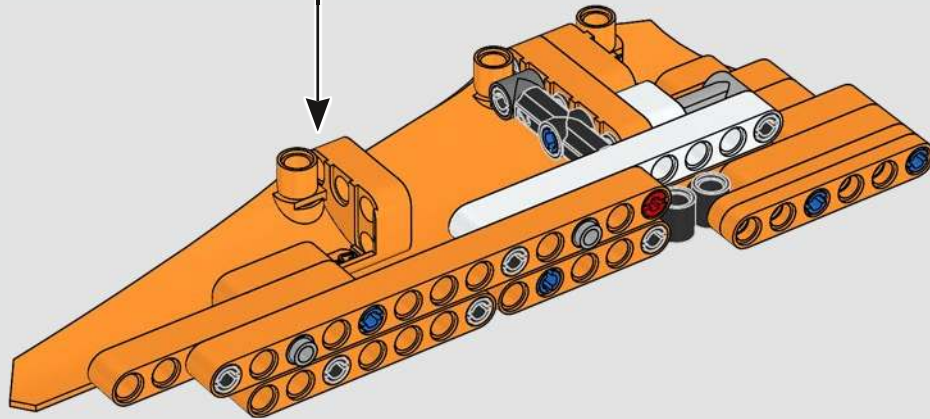

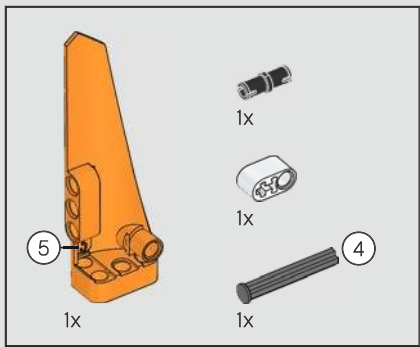

272

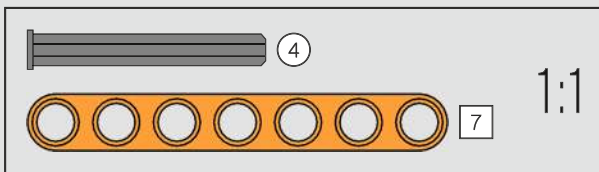
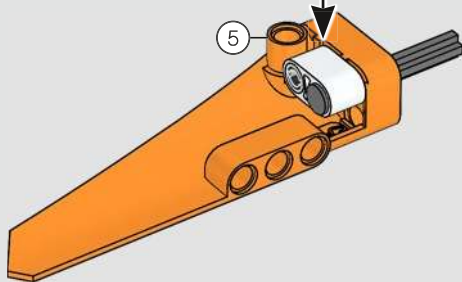
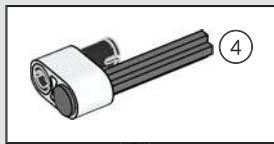

254



273

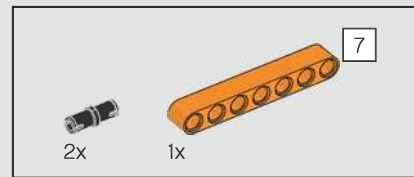
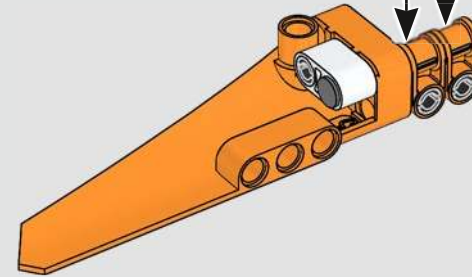

274

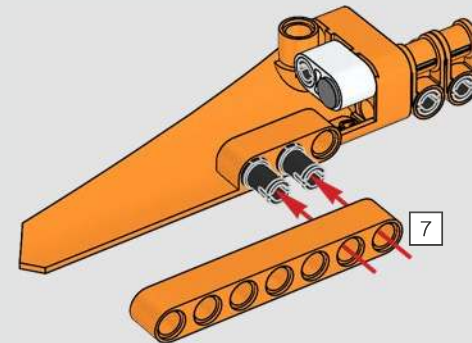

275

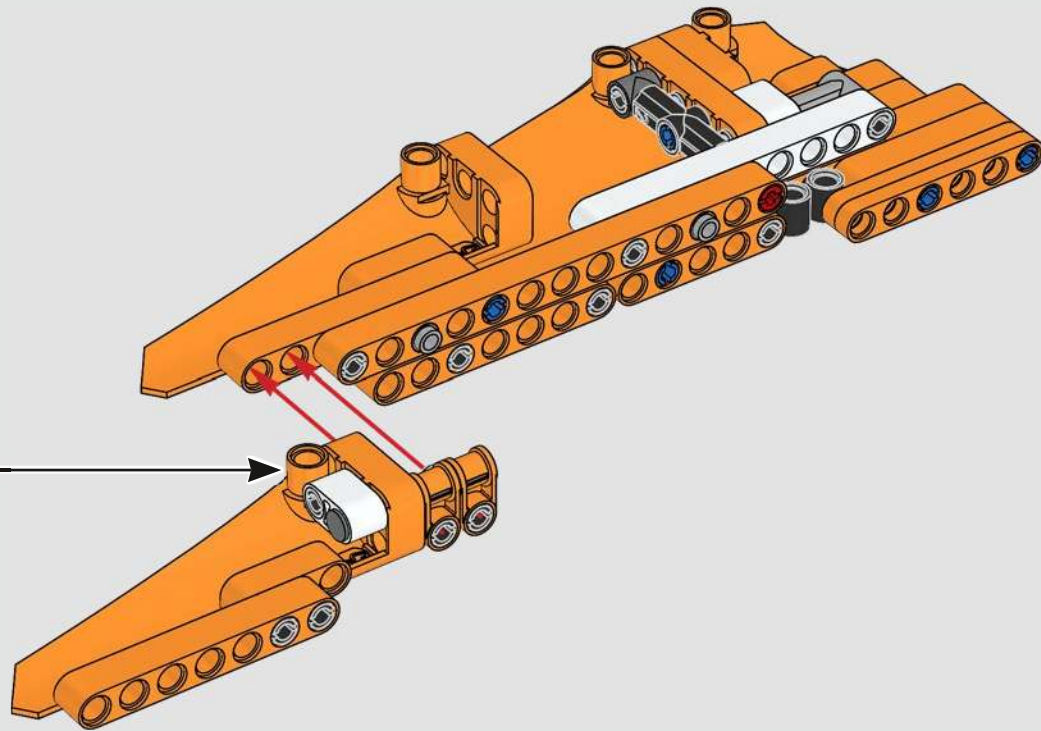

276

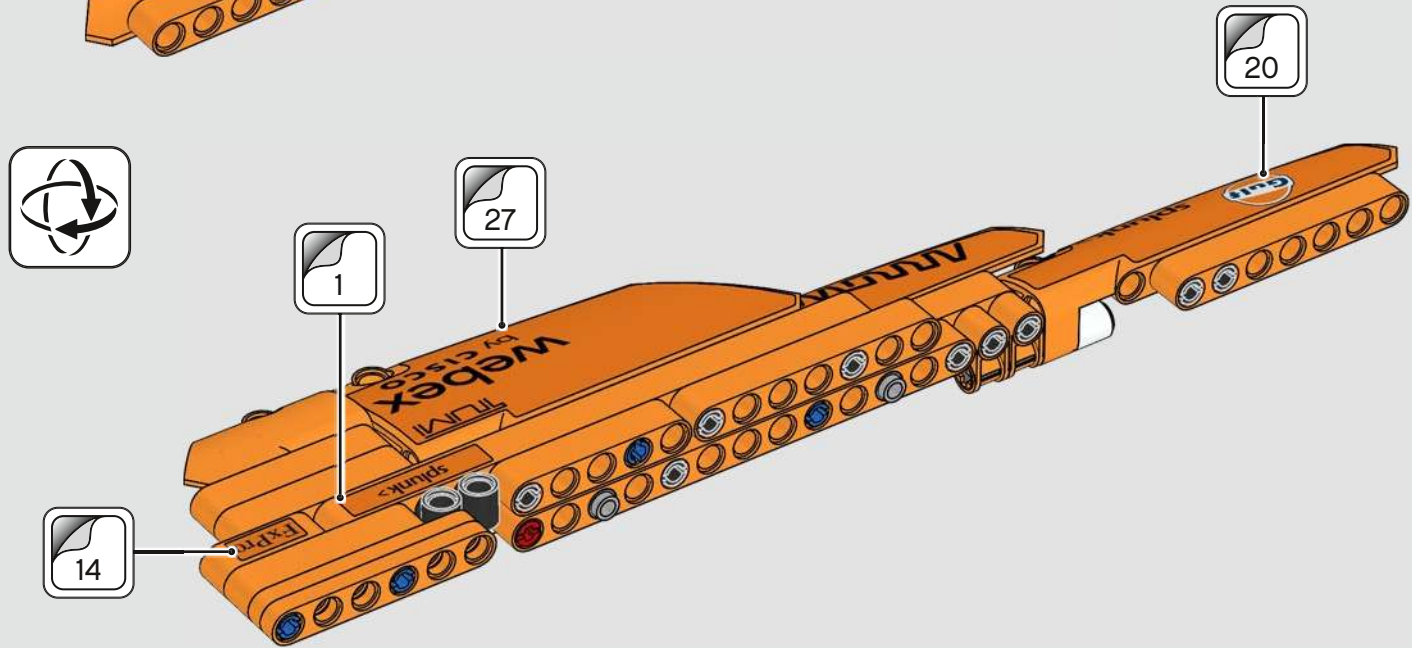

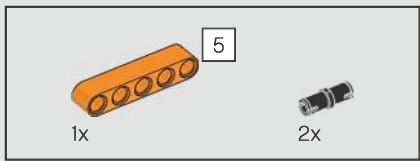

277

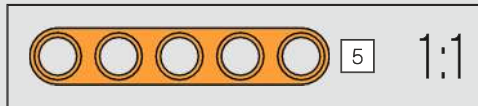
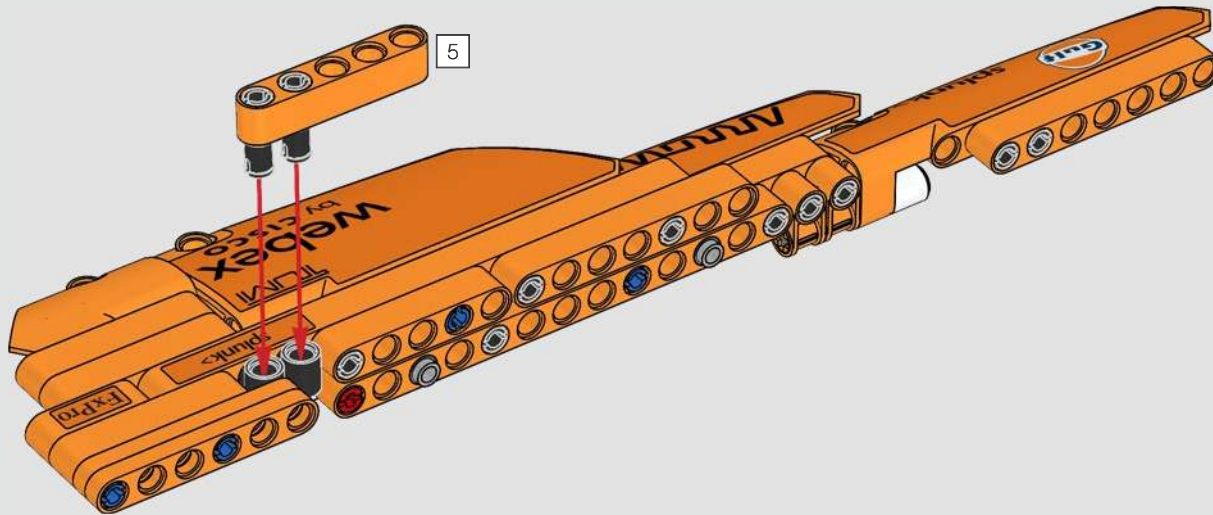

256

278

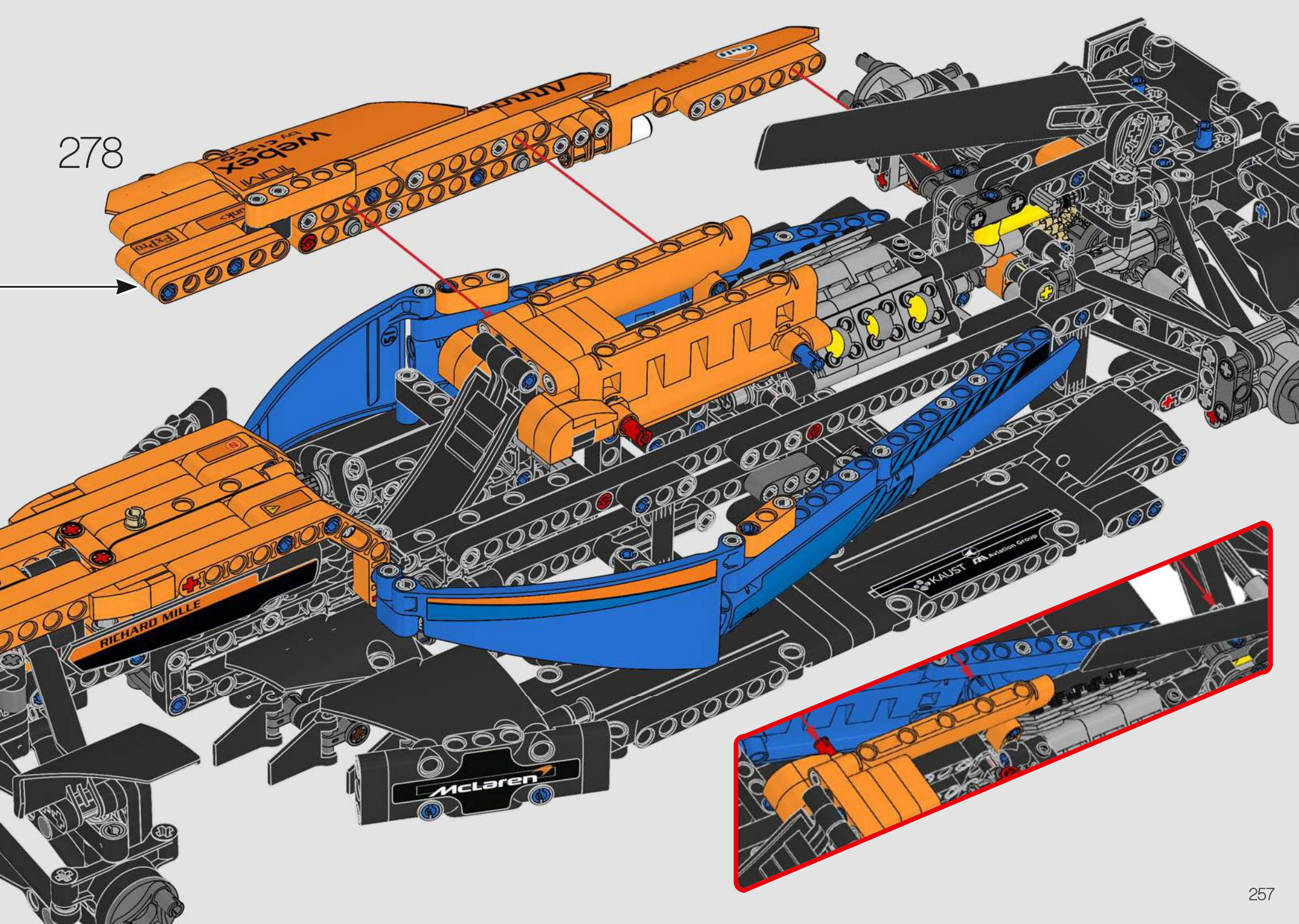

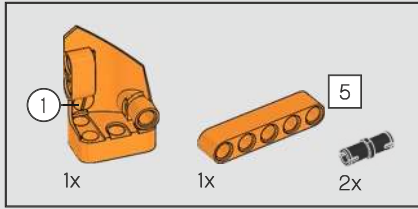
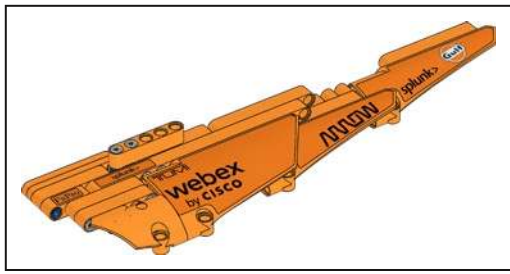

279

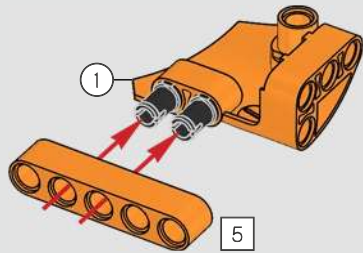

258

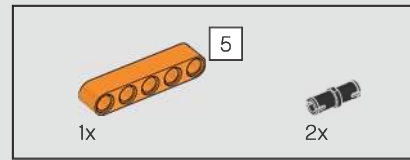
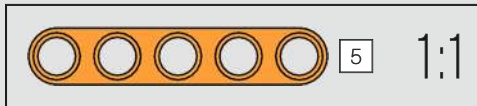

280

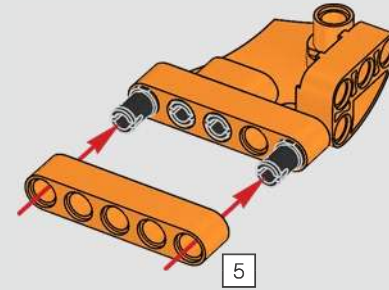

281

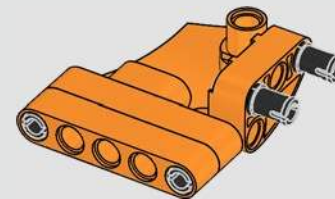

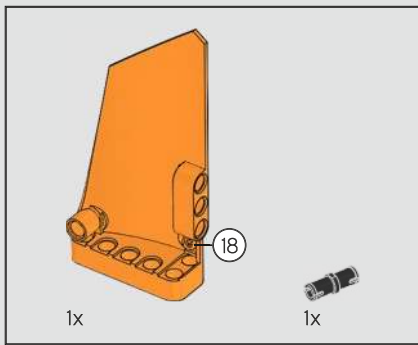

282

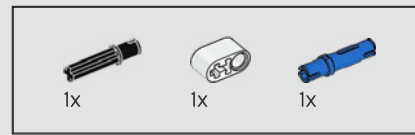
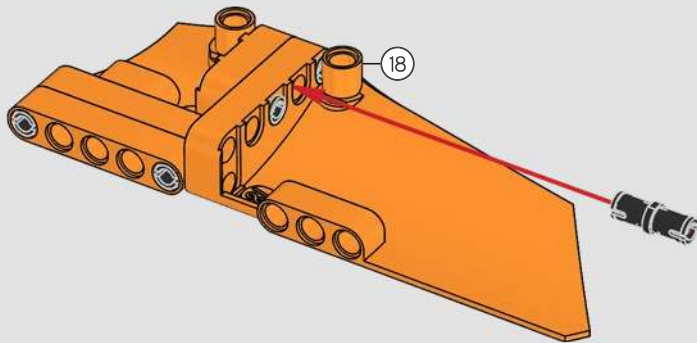

283

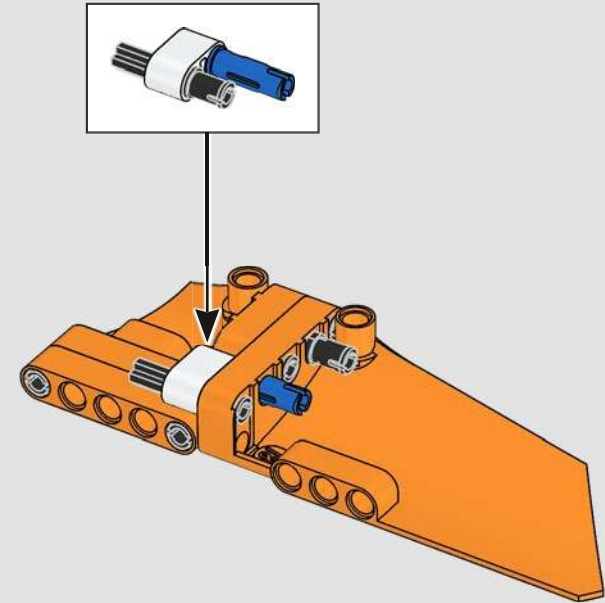

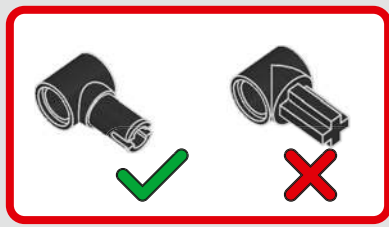
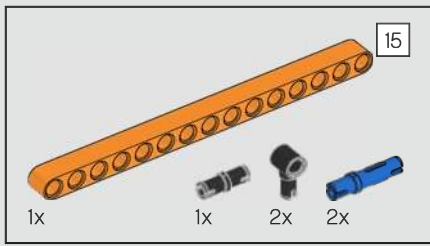

284

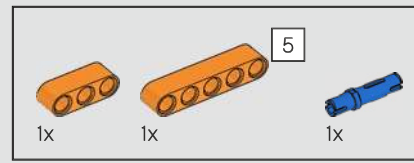
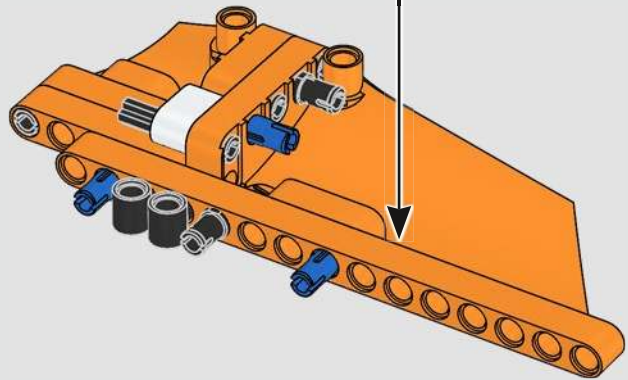
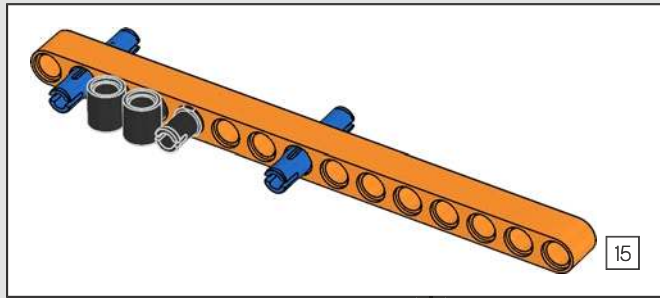

285

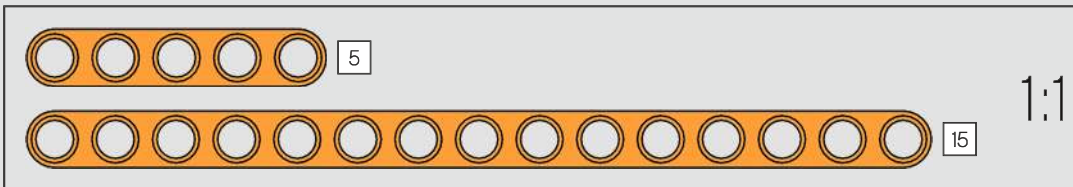
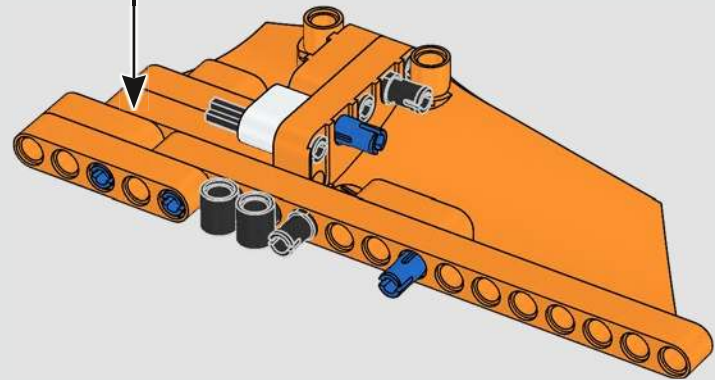
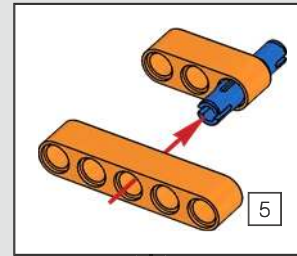

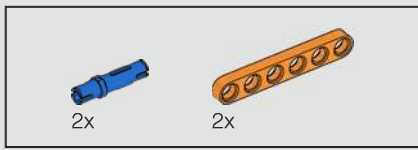

286

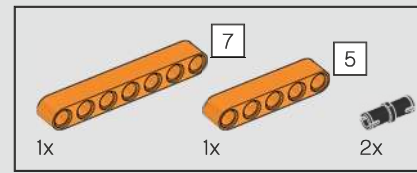
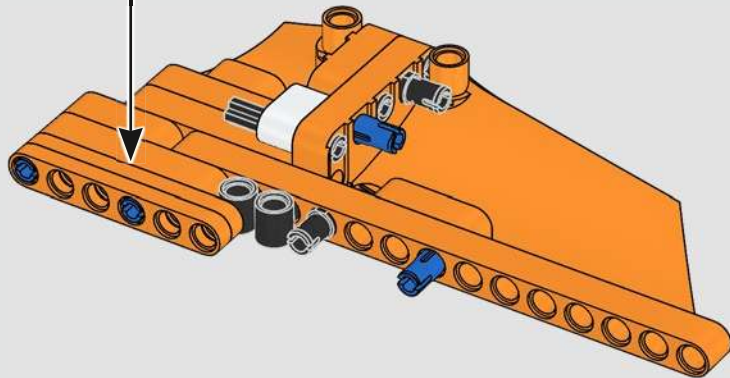
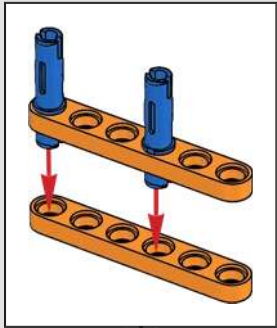

287

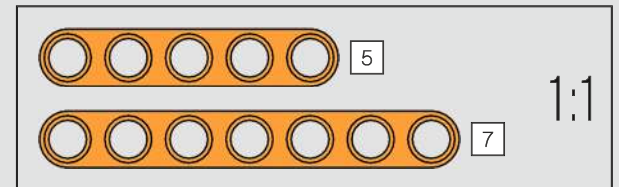
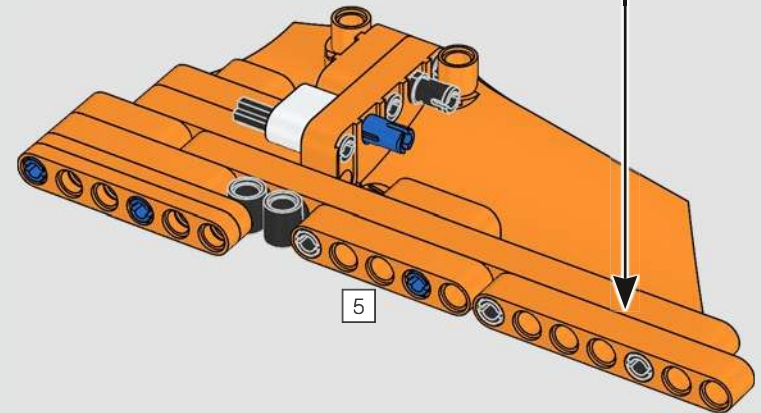
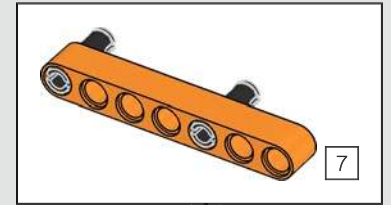

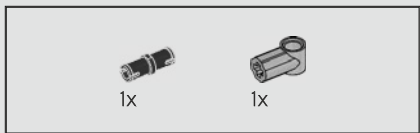

288

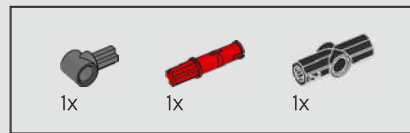
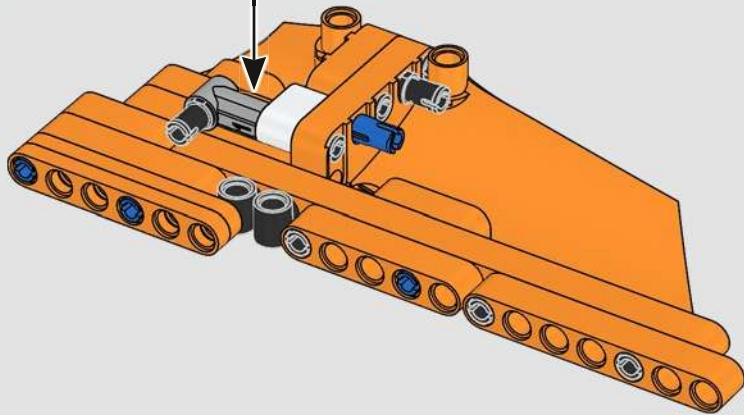

289

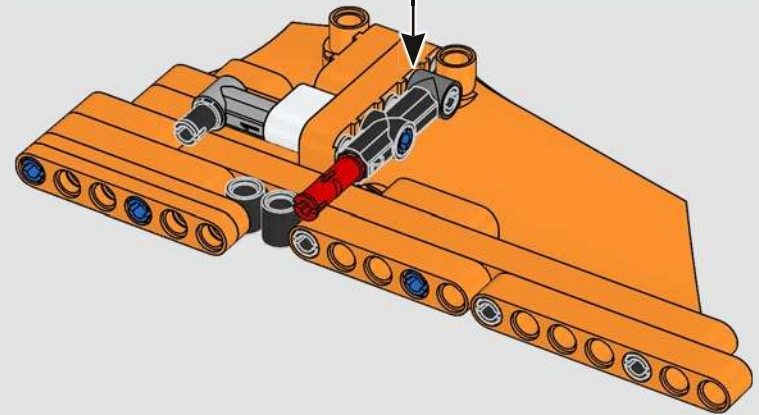
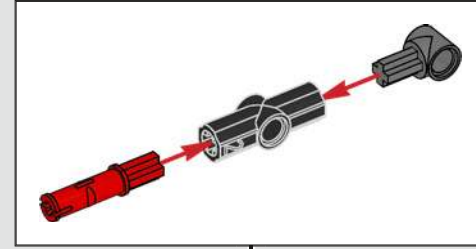

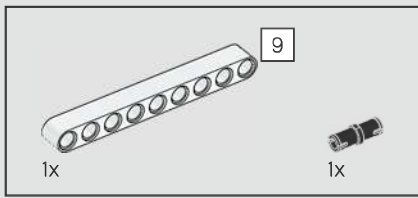

290

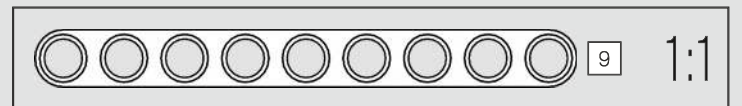
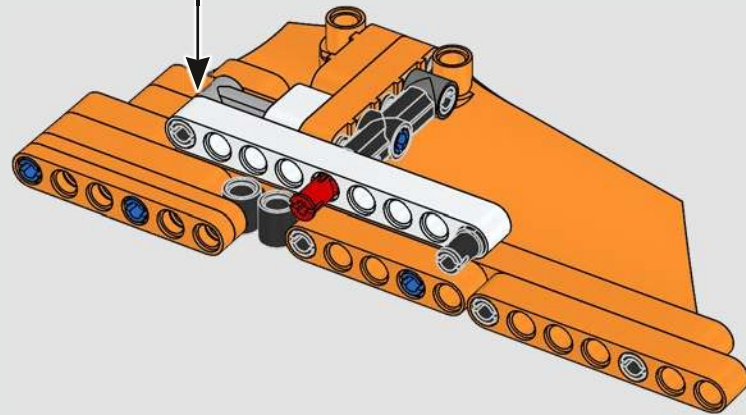
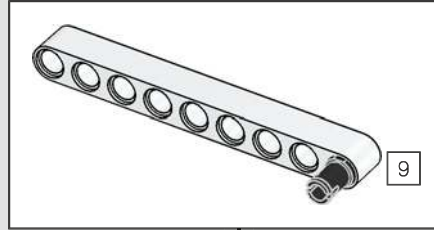

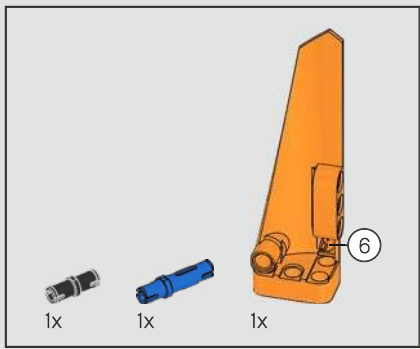

291

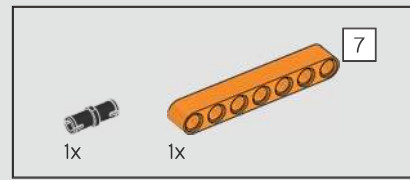
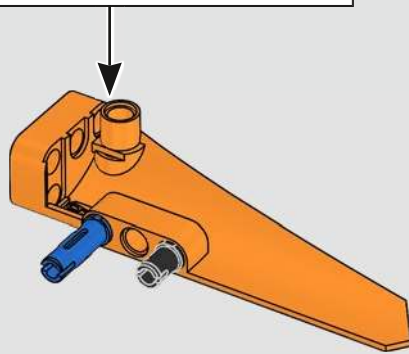
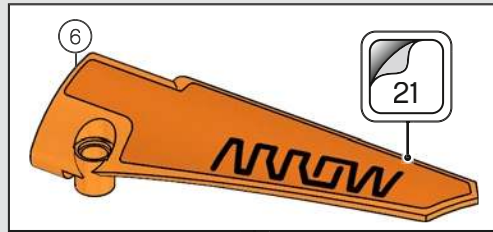

292

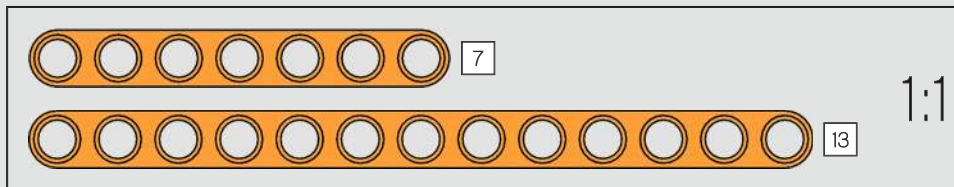
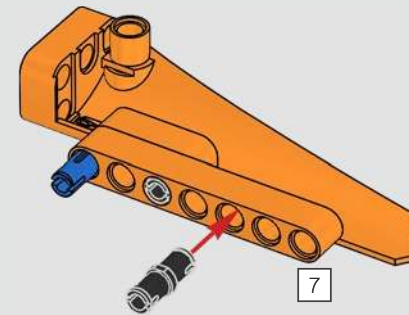

264

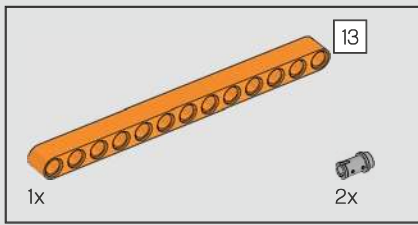

293

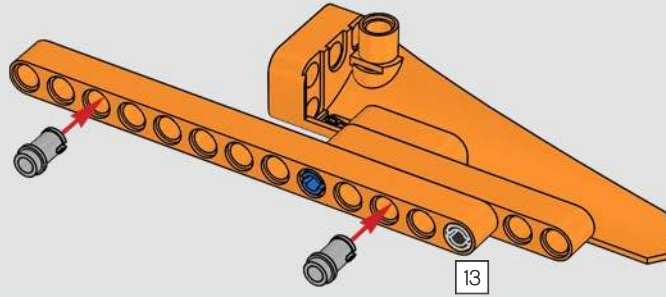

294

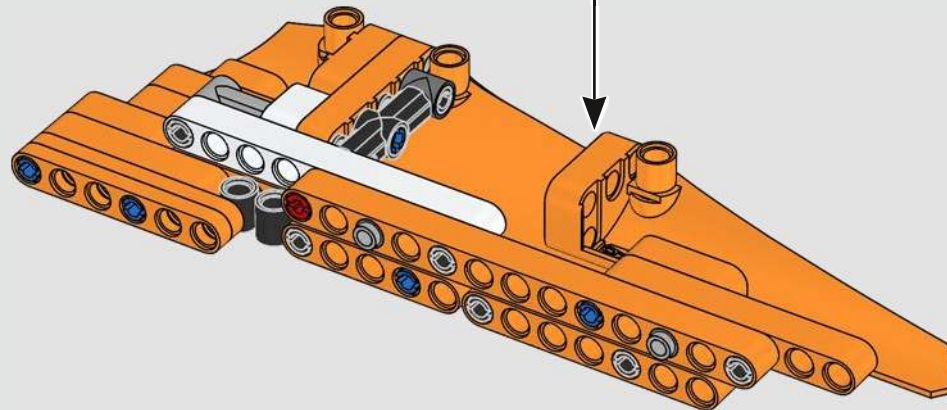

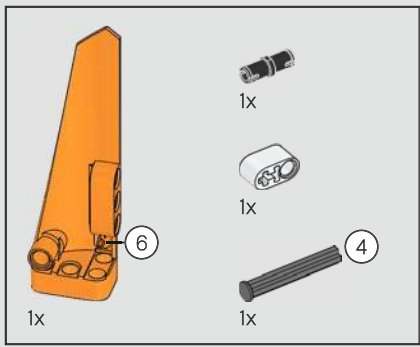

295

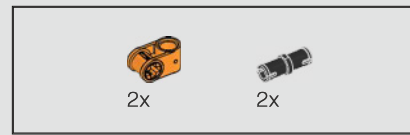
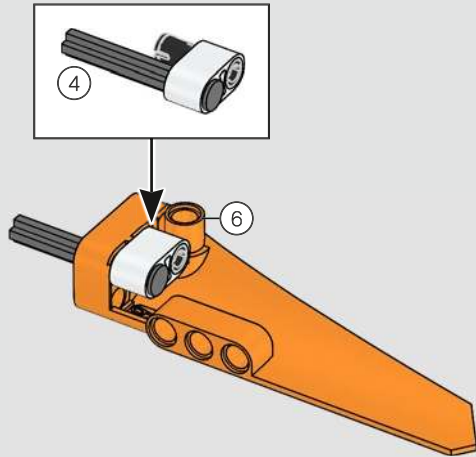

296

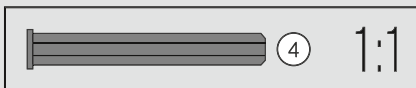
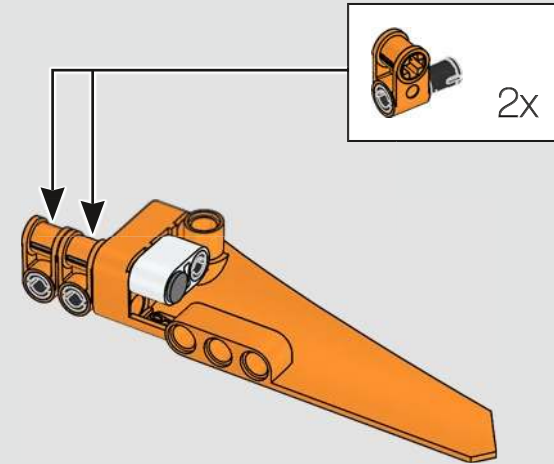

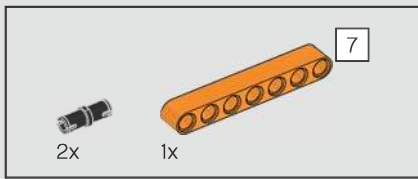

297

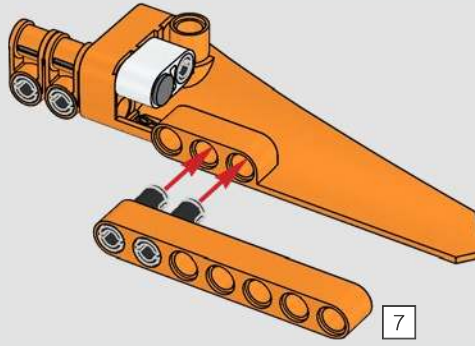

298

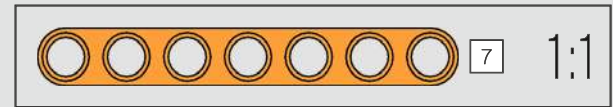
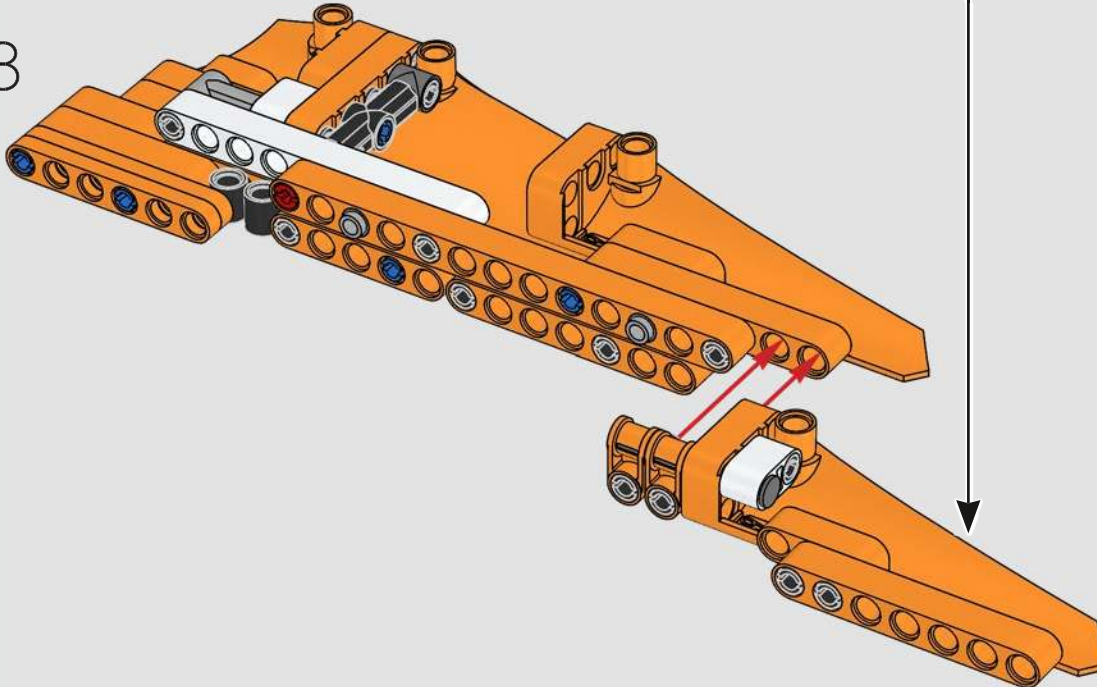

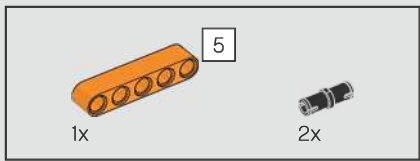

299

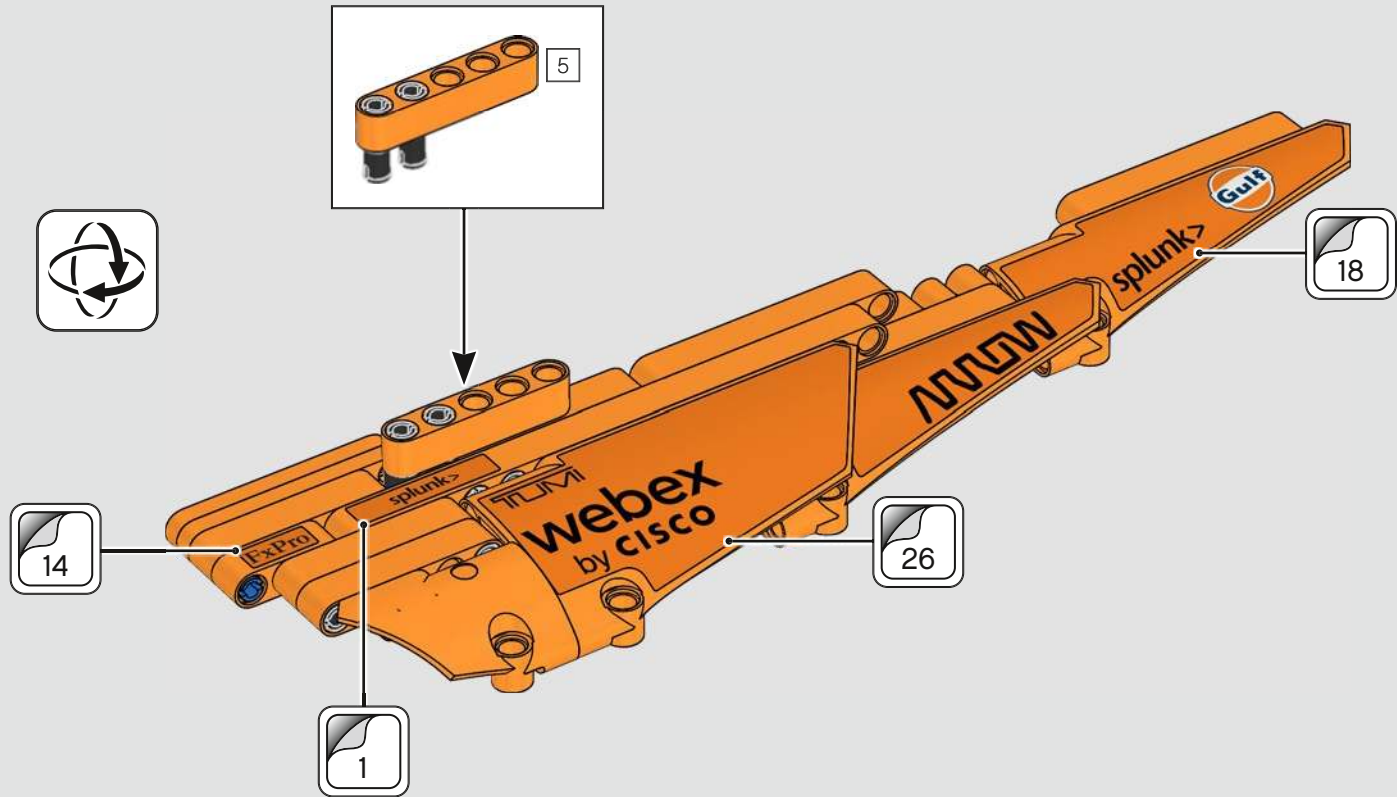

268

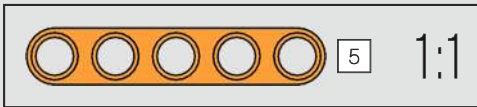

300

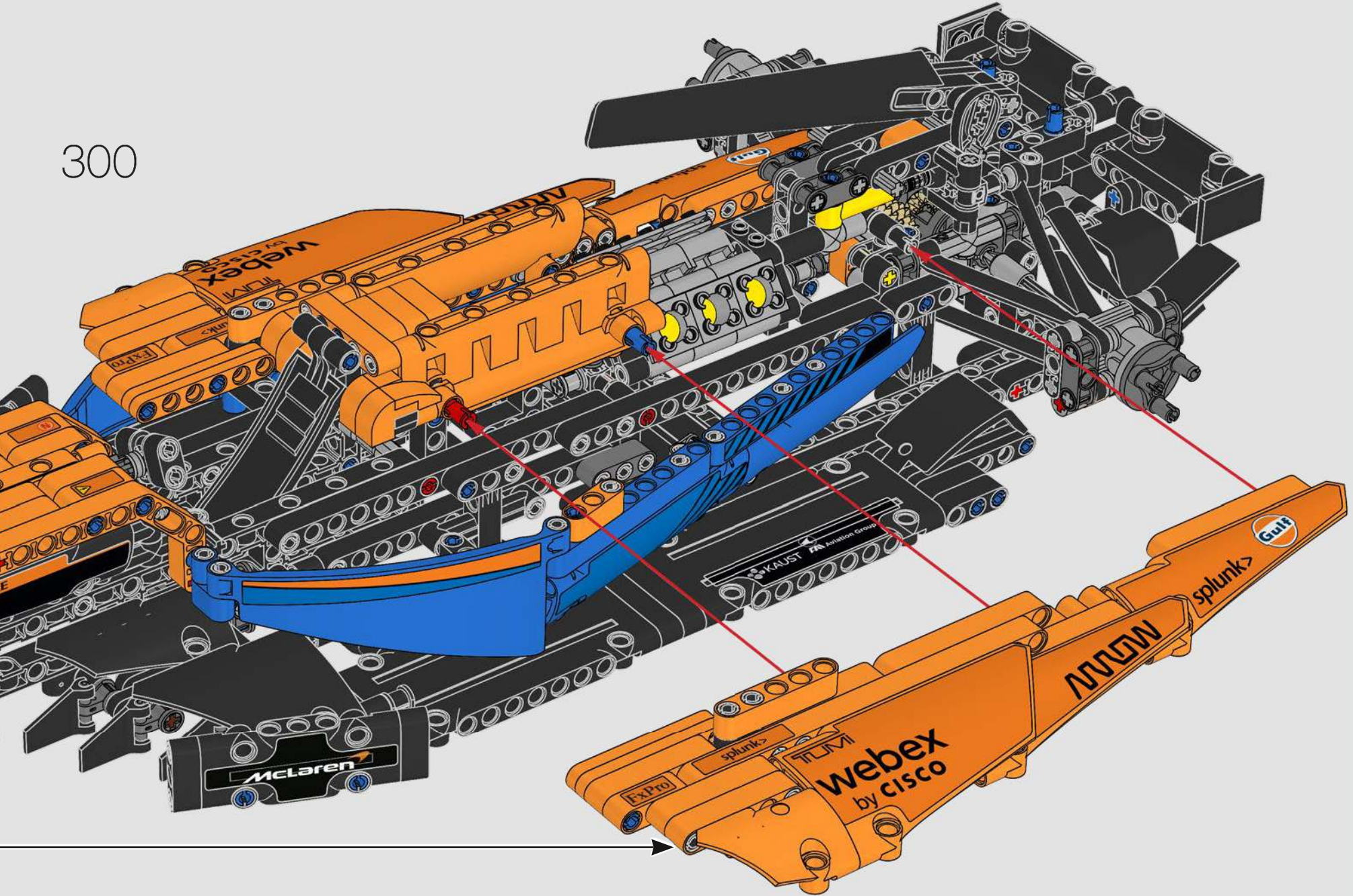

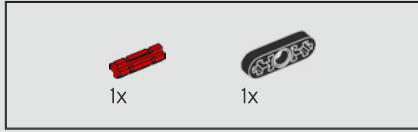

301

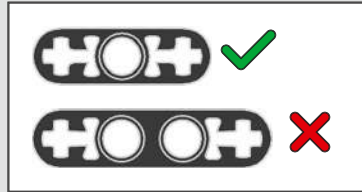

302

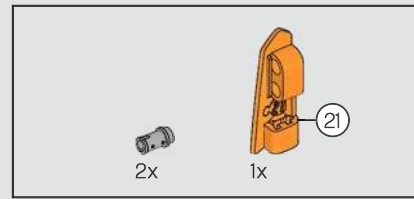
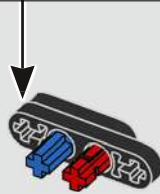
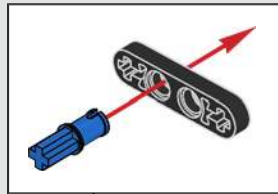

303

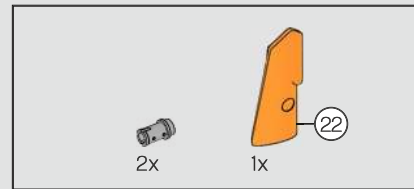
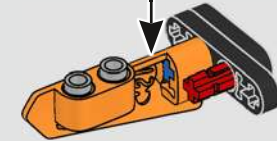
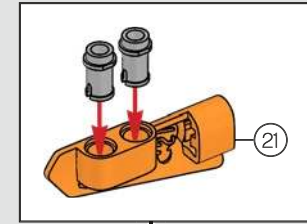

304

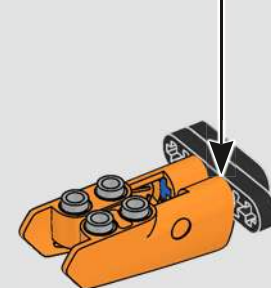
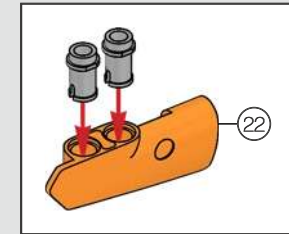

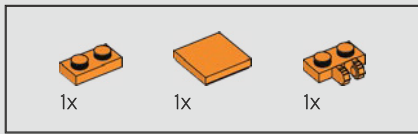

305

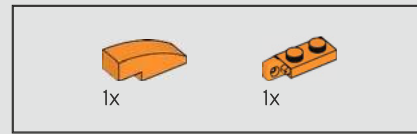
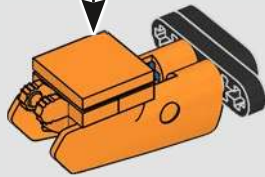
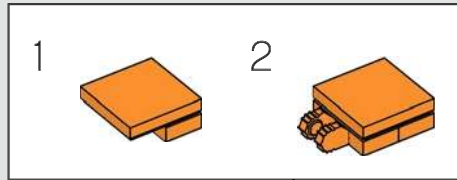

306

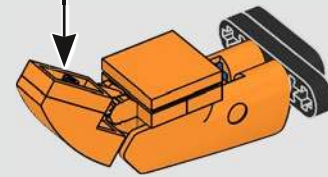
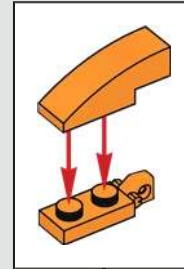

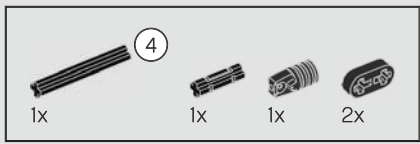

307

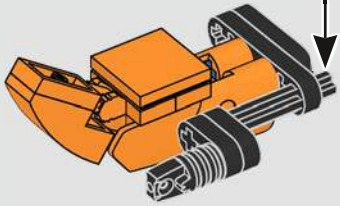
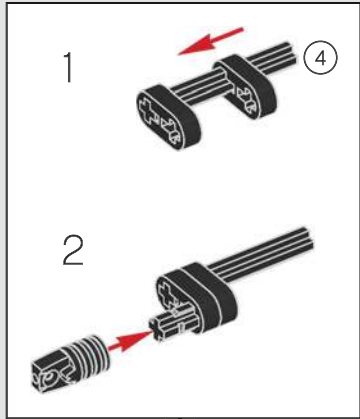

308

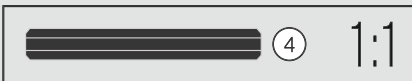
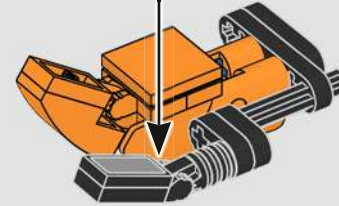
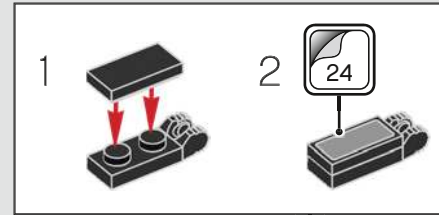

309

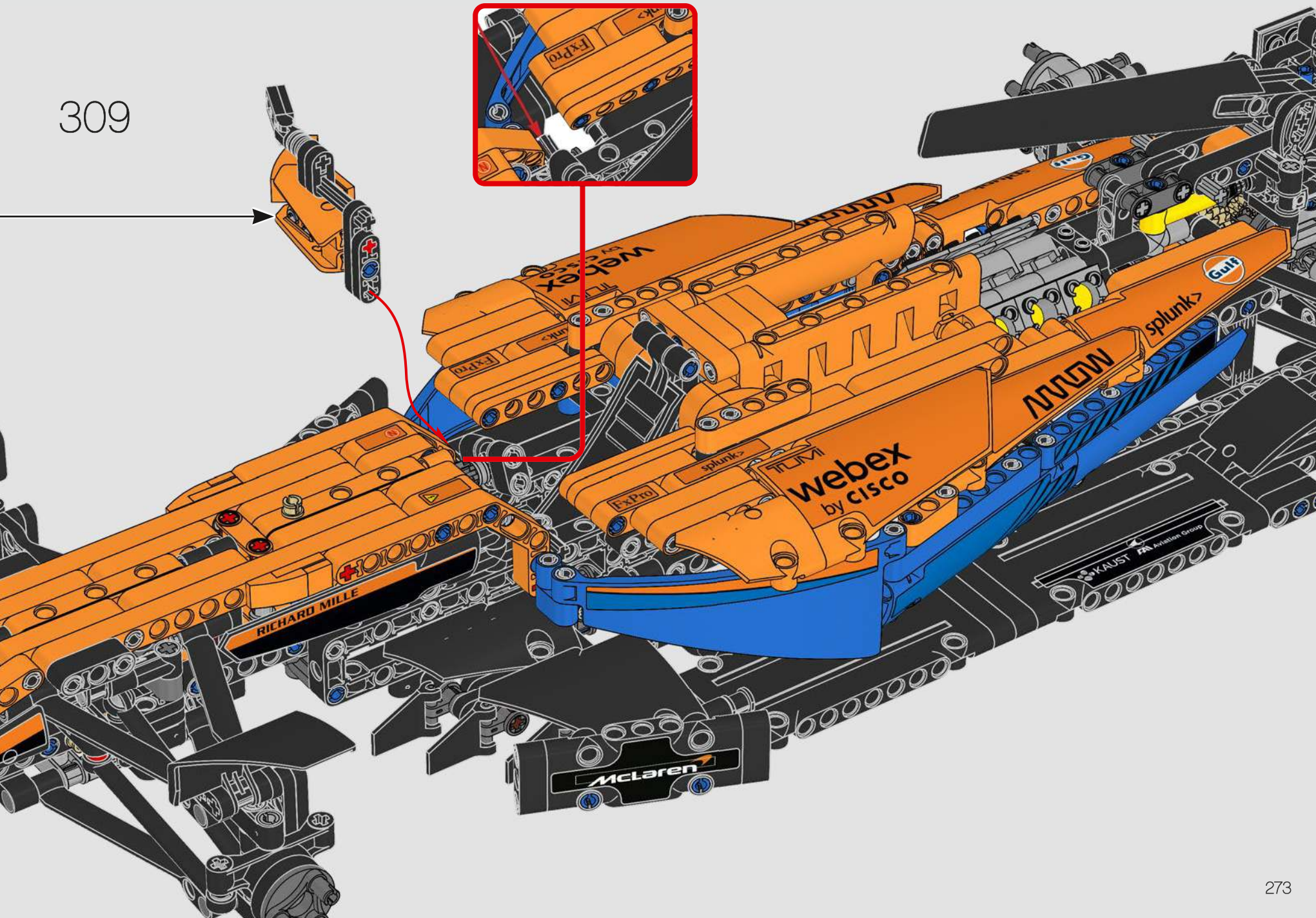

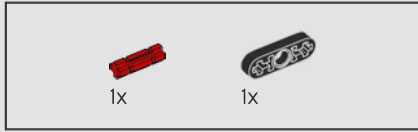
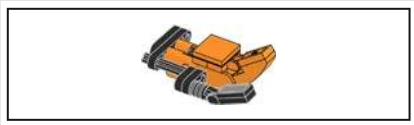

310

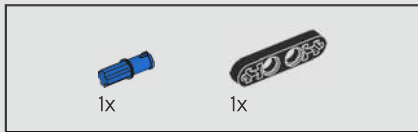
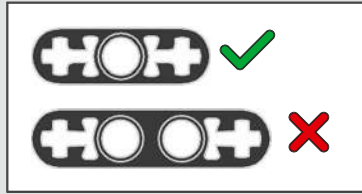

311

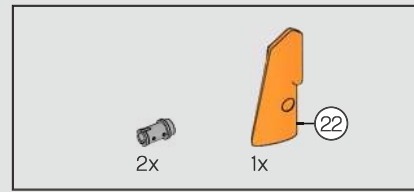
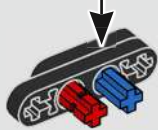
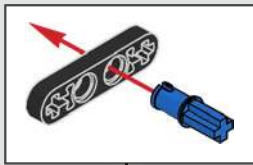

312

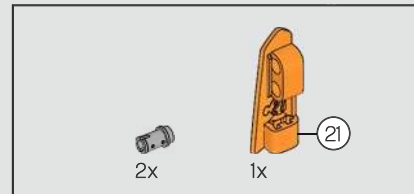
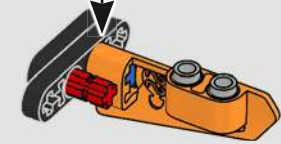
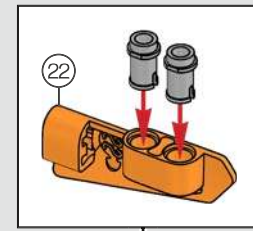

313

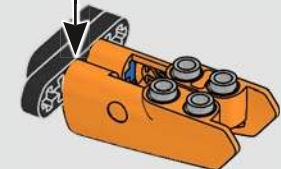
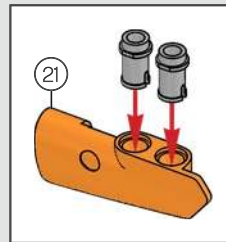

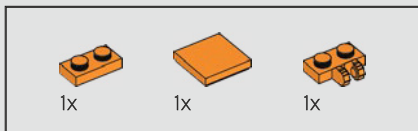

314

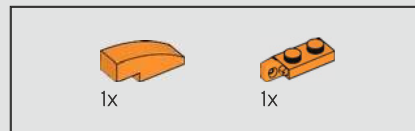
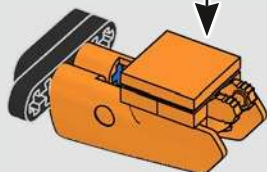
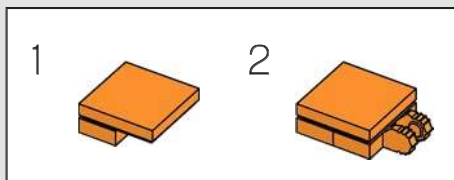

315

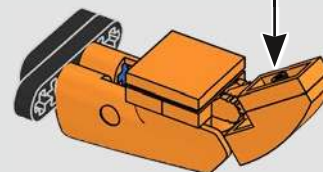
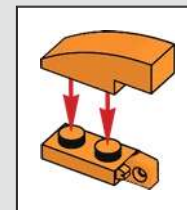

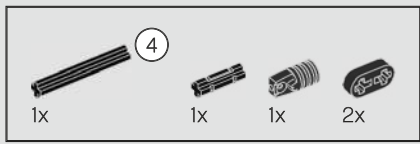

316

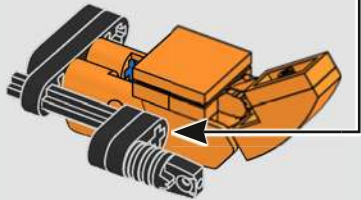
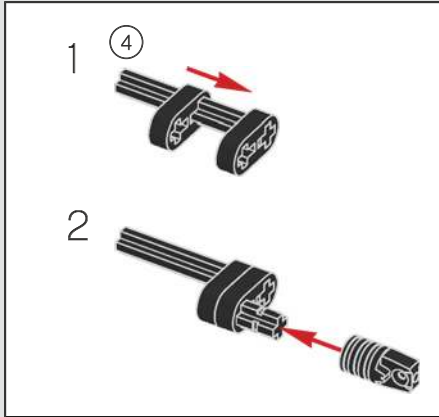

317

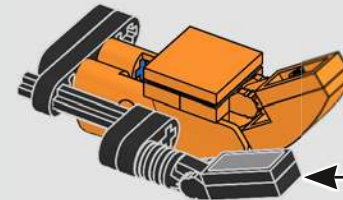
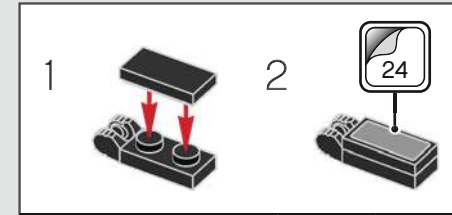

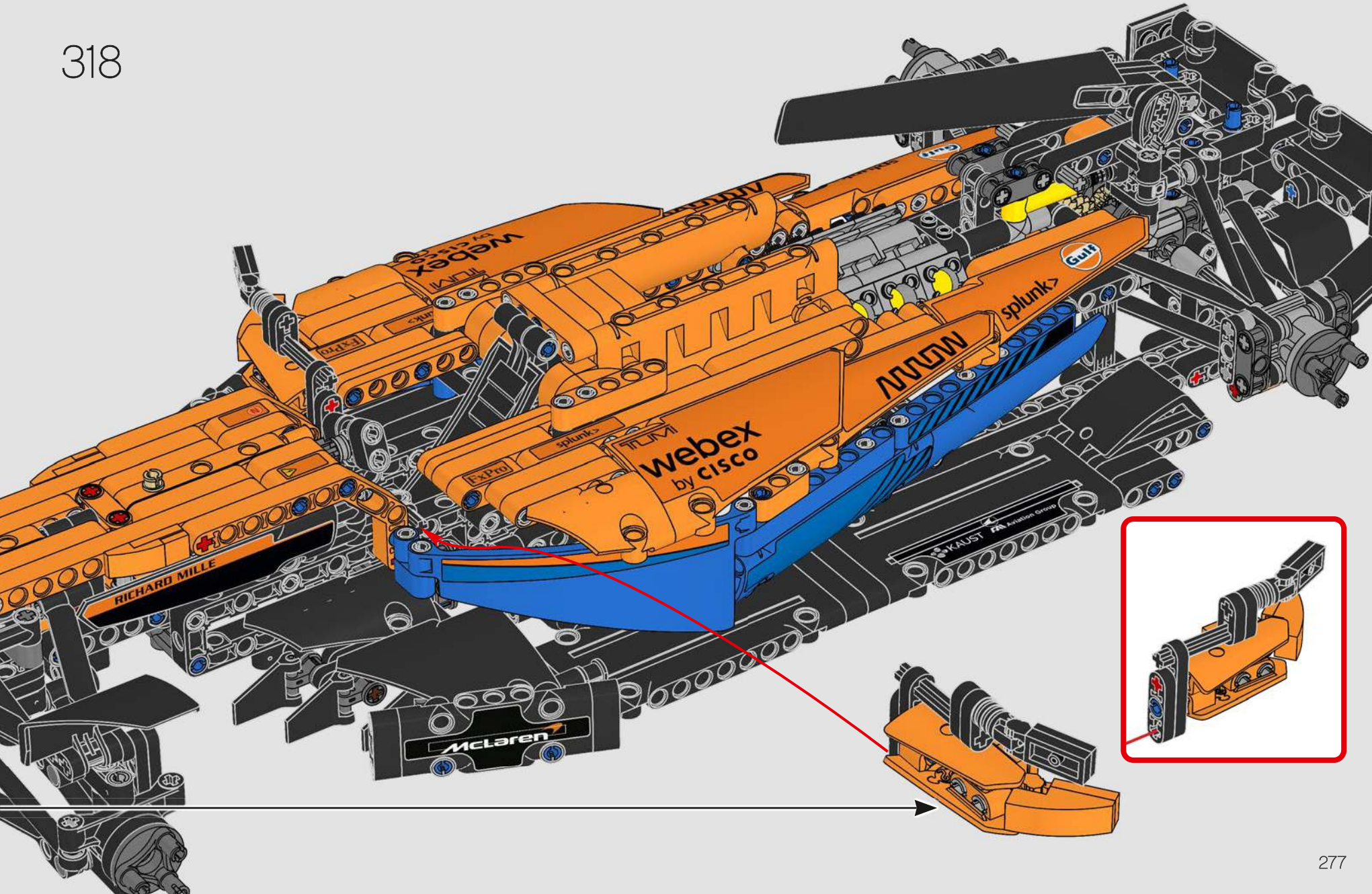

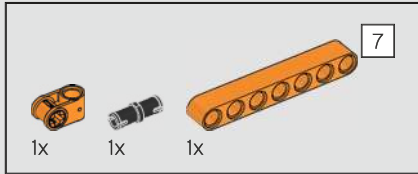
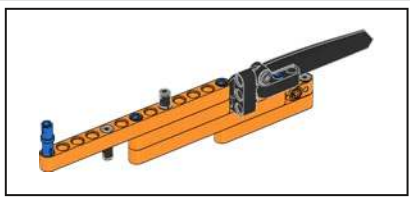

319

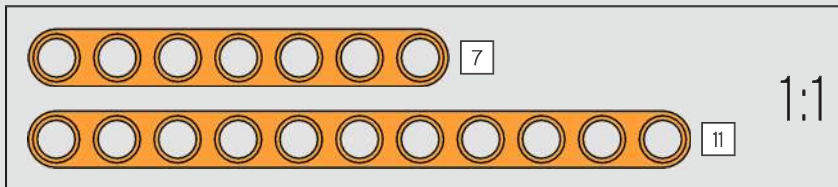
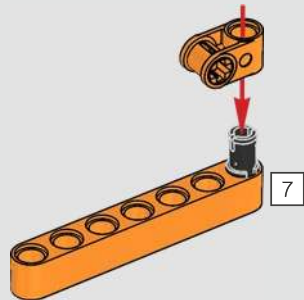

278

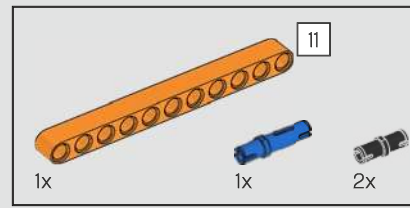

320

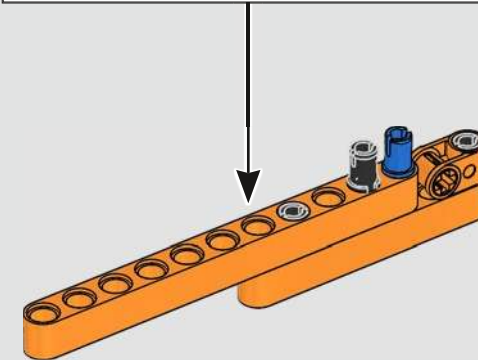
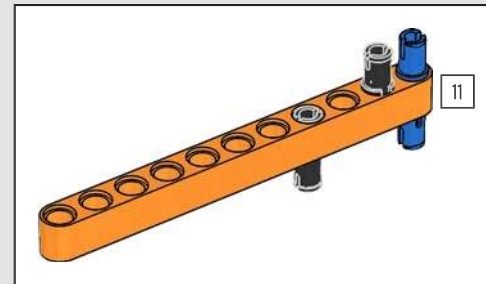

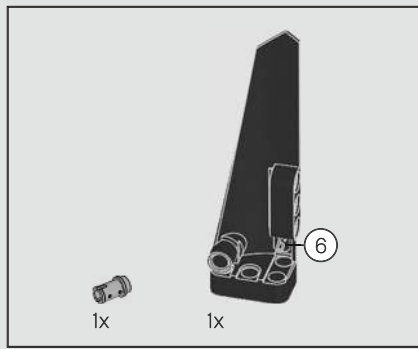

321

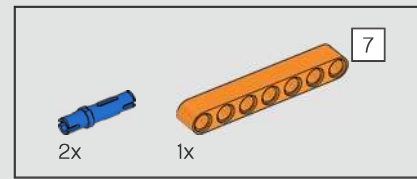
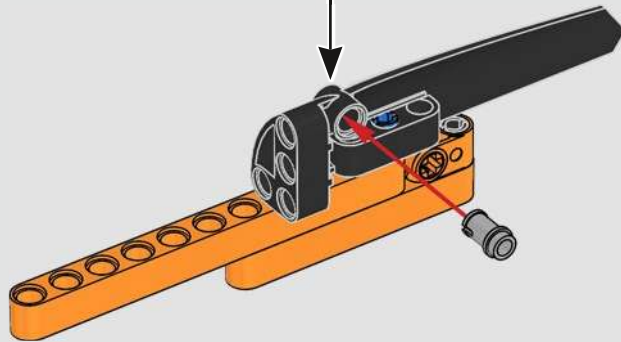
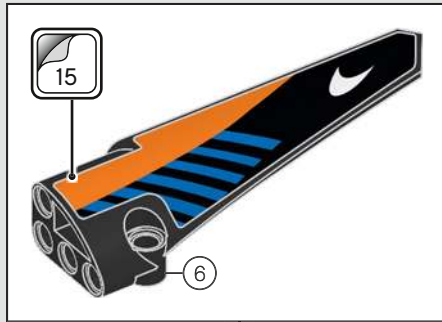

322

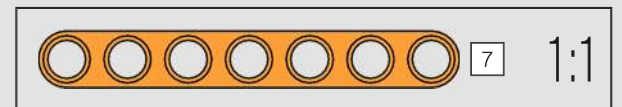
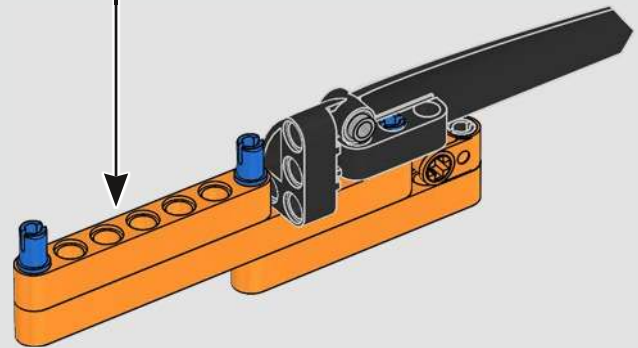
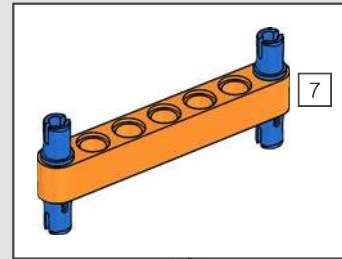

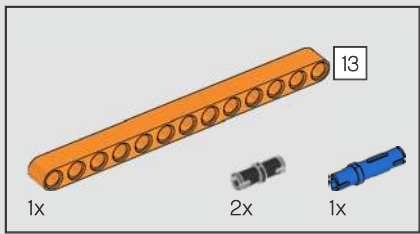

323

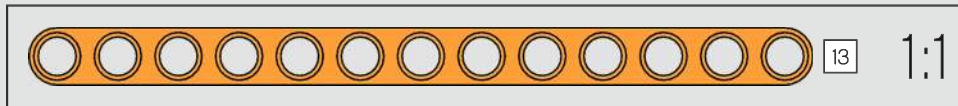
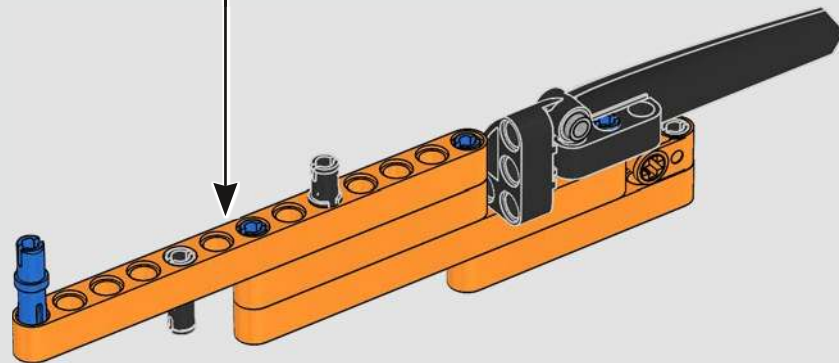
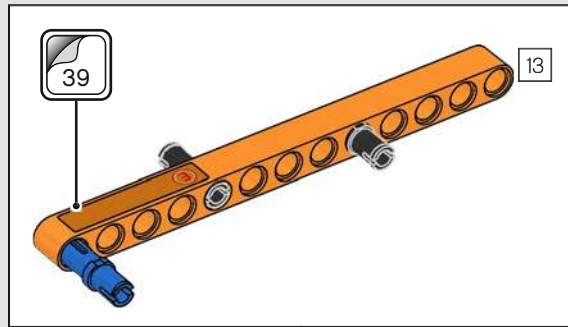

324

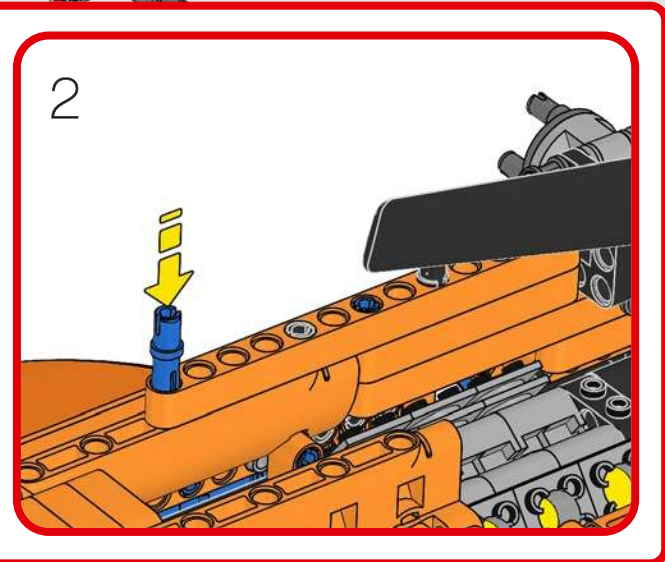
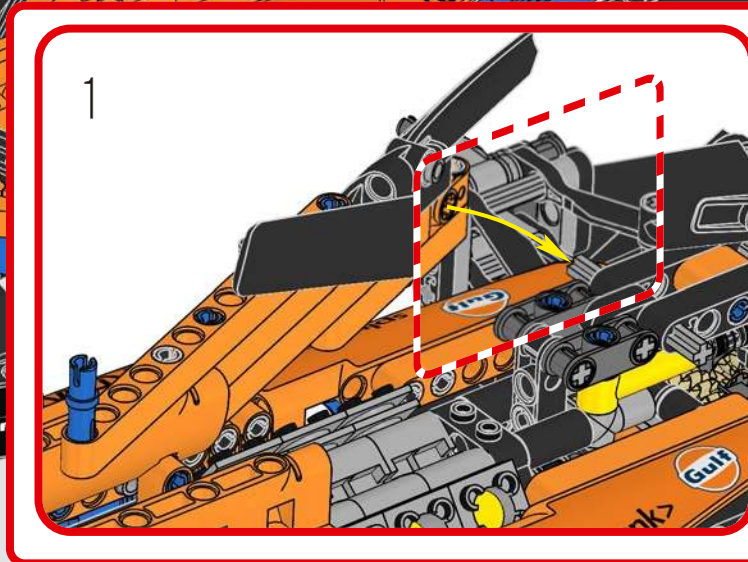
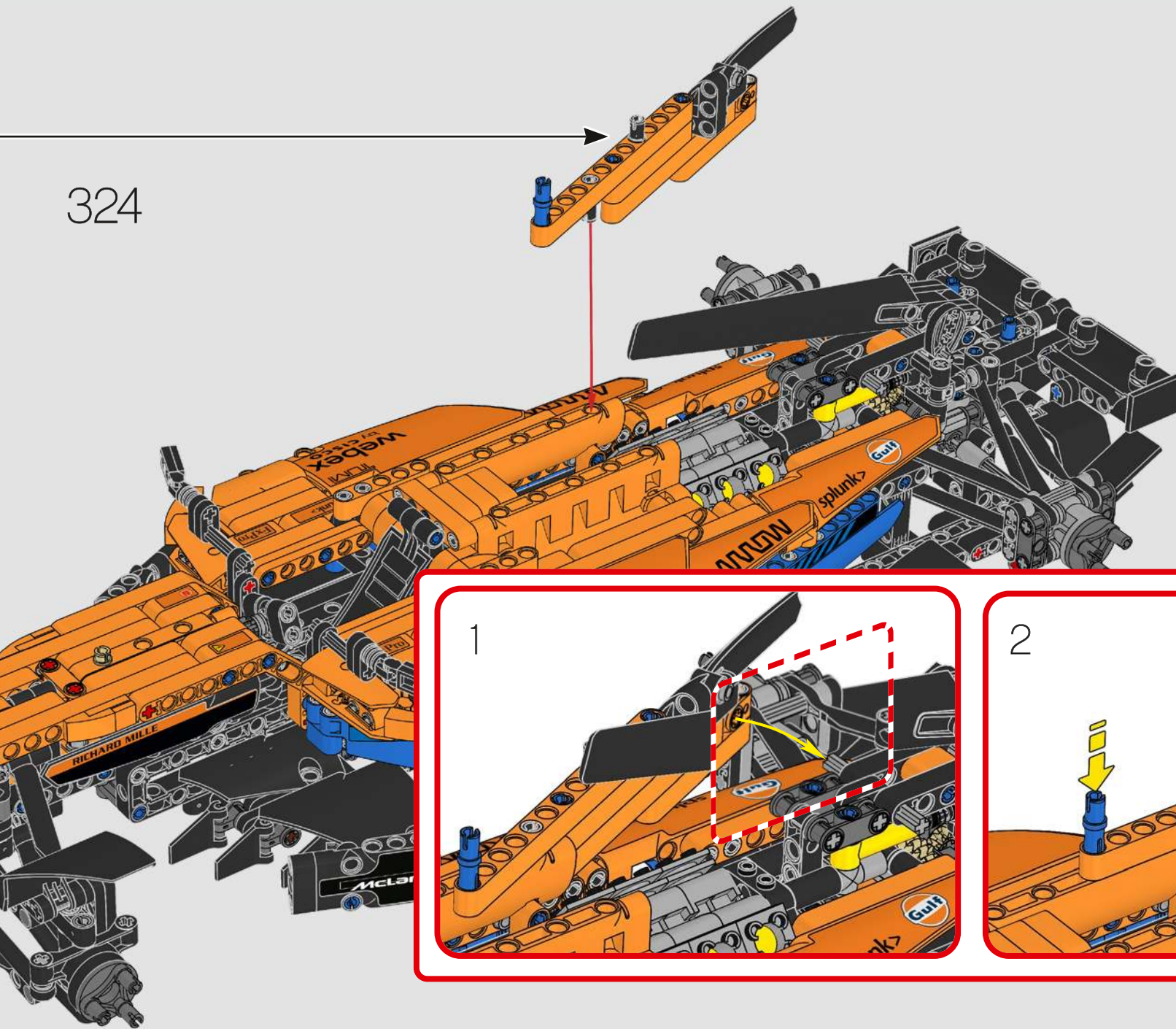

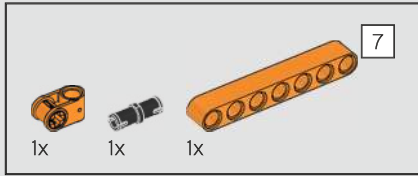
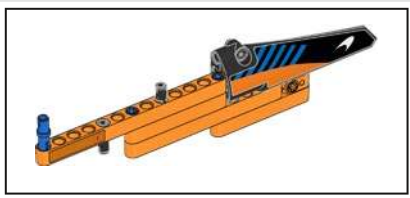

325

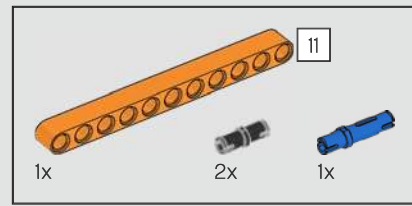
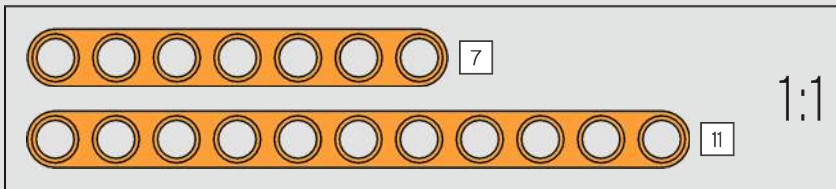
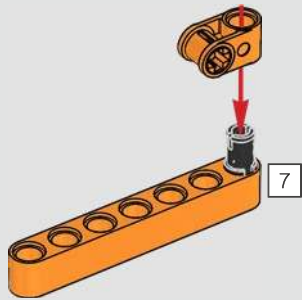

326

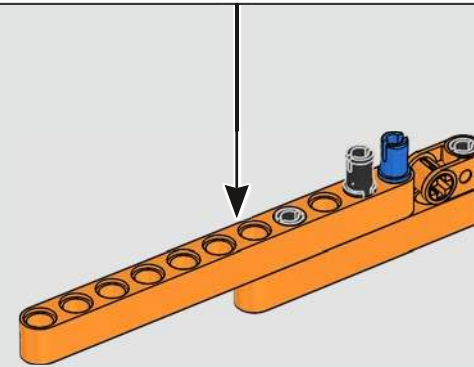
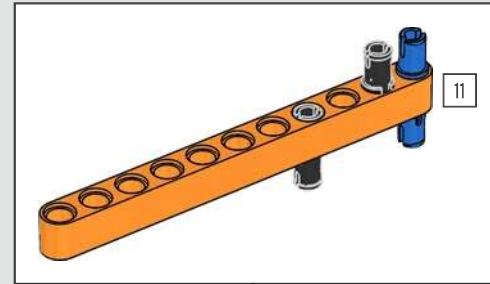

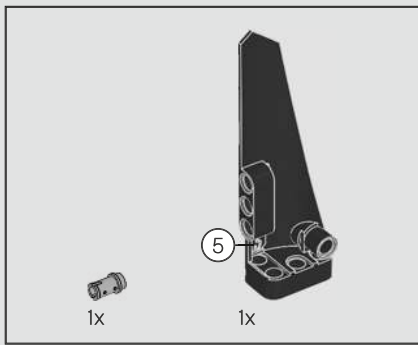

327

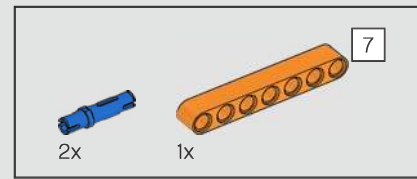
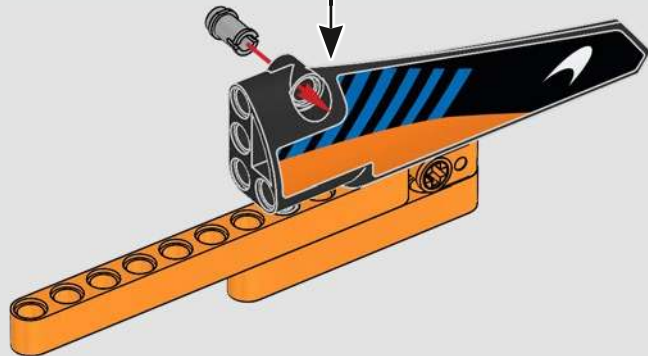

328

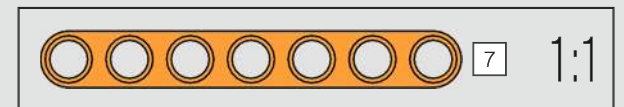
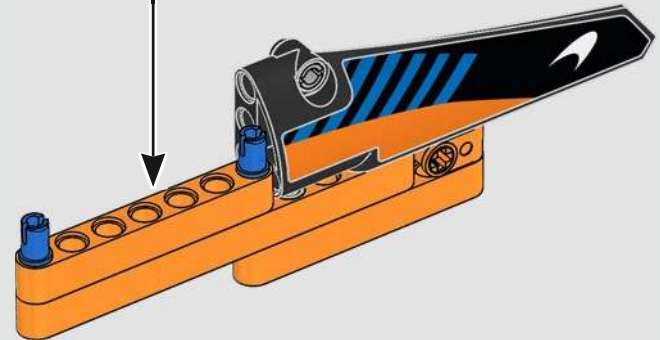
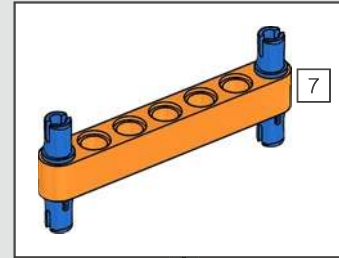

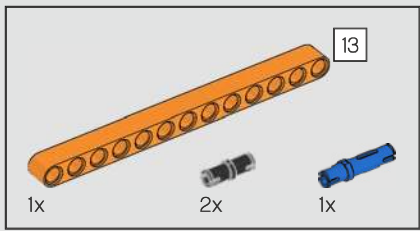

329

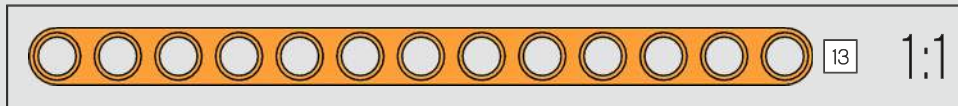
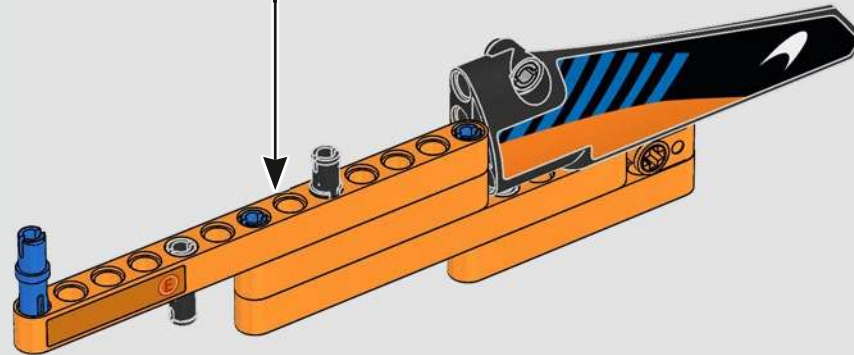
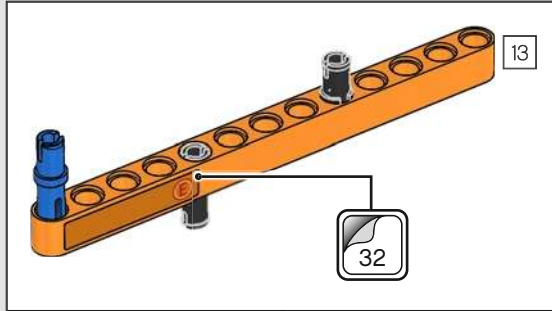

330

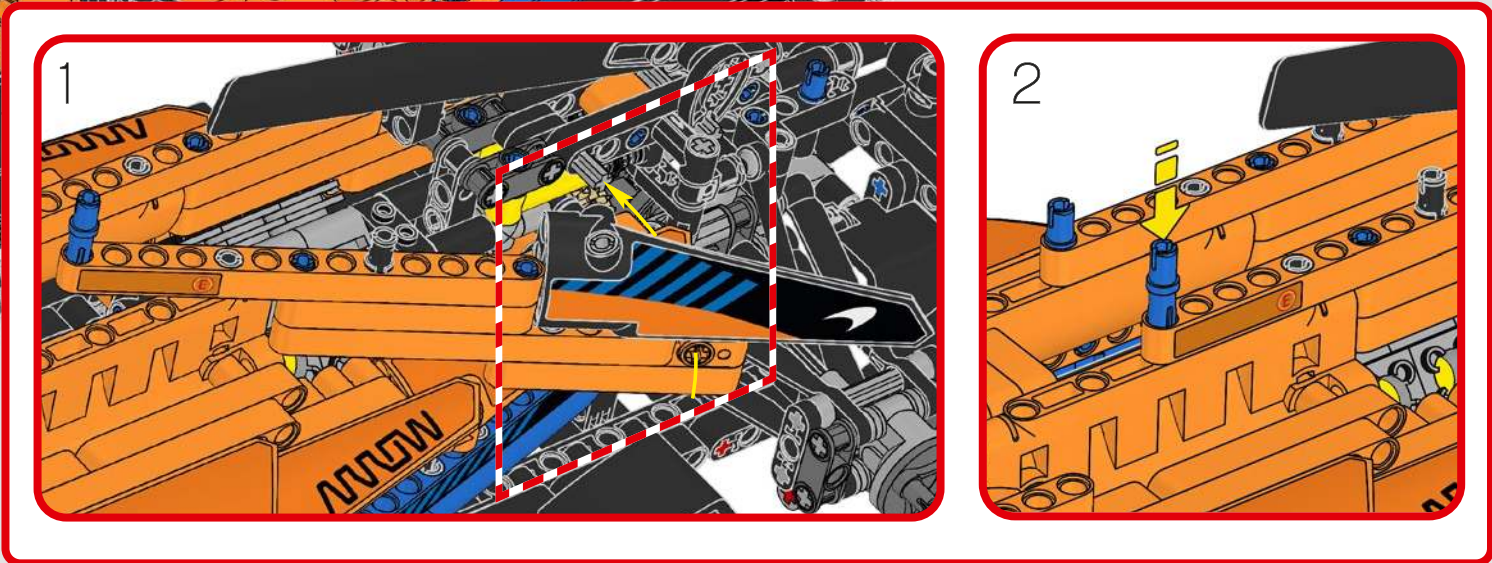
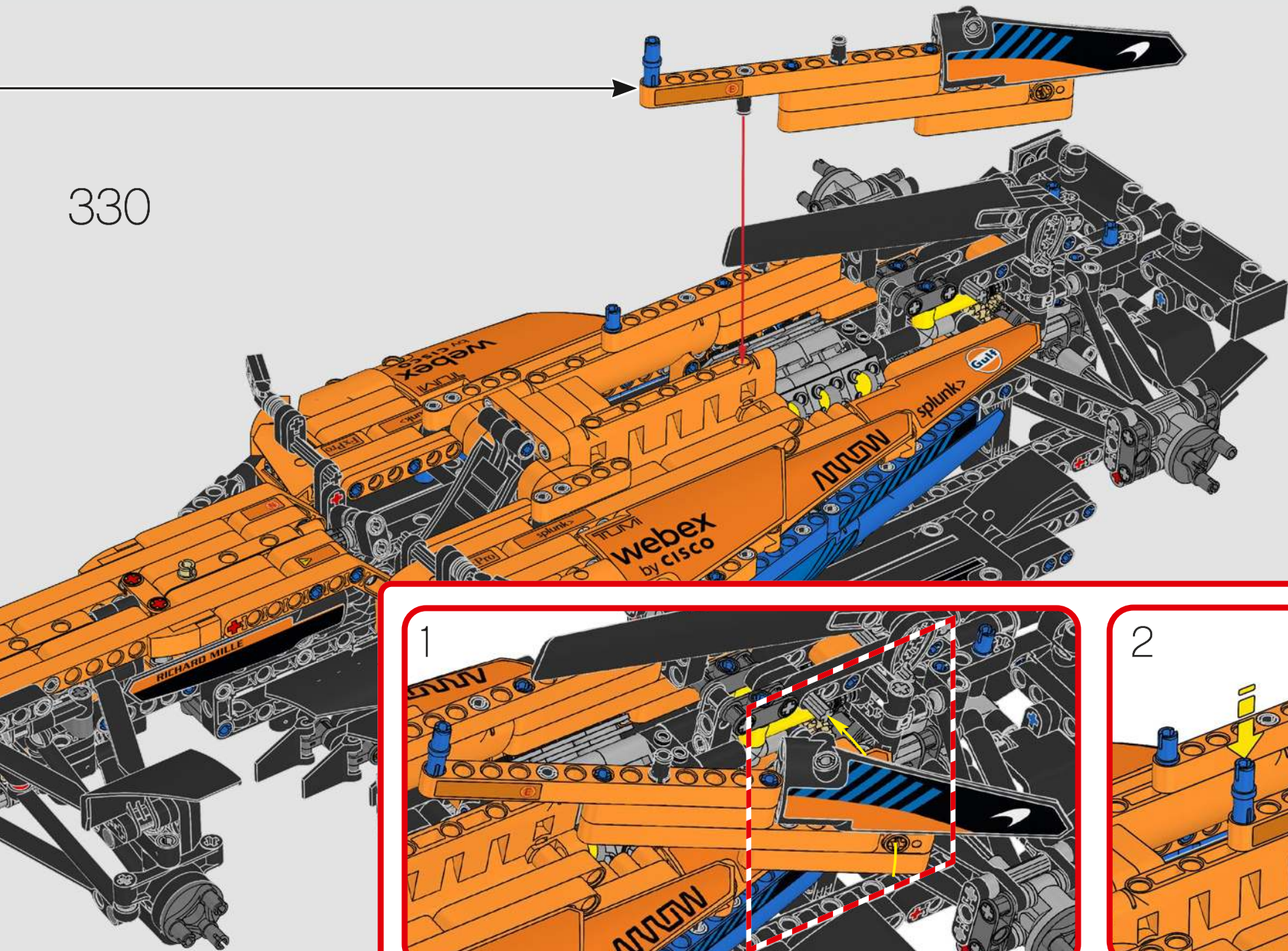

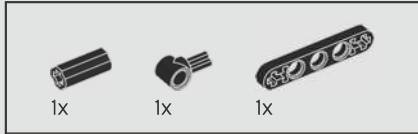
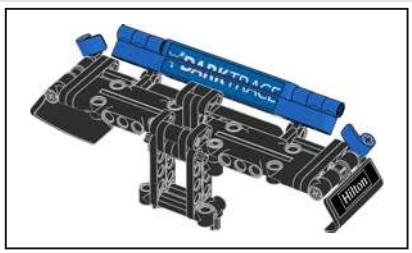

331

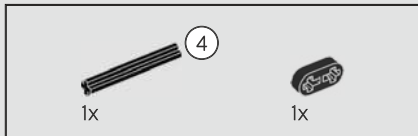
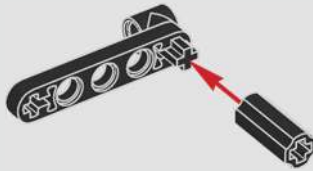
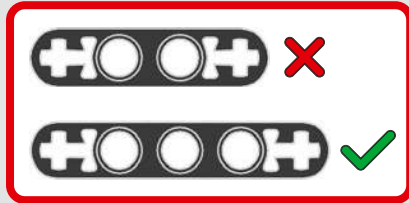

332

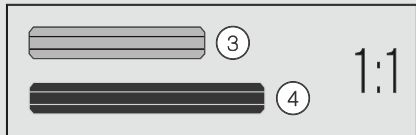
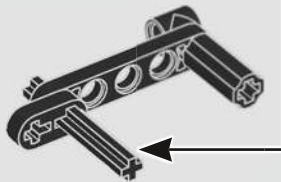
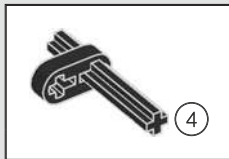

2x

333

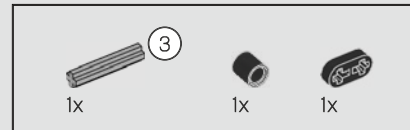
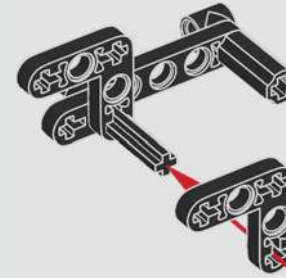

334

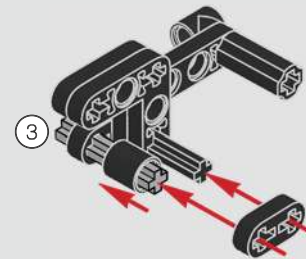

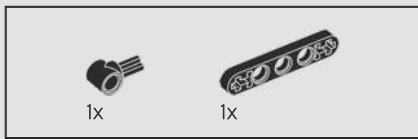

335

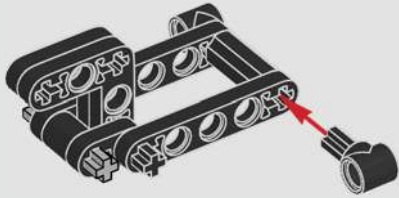

336

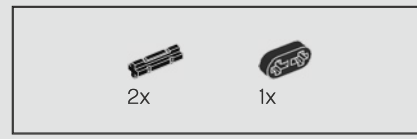
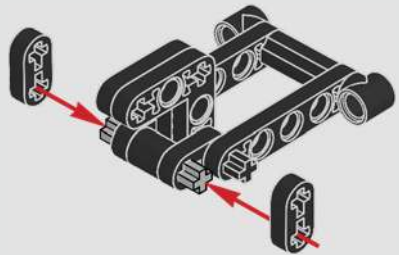

337

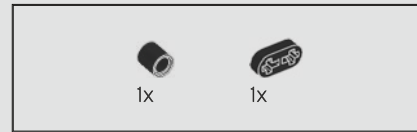
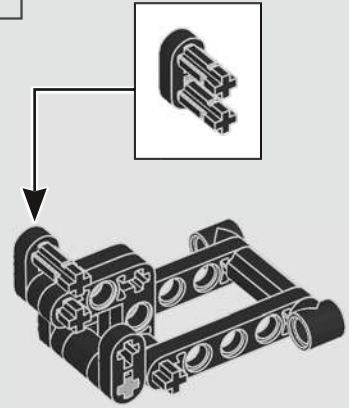

338

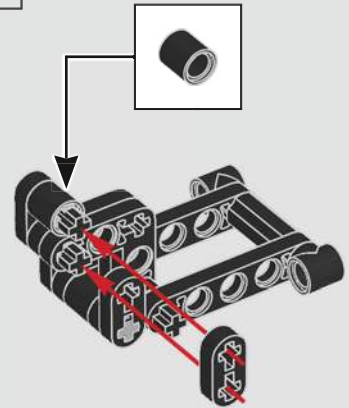

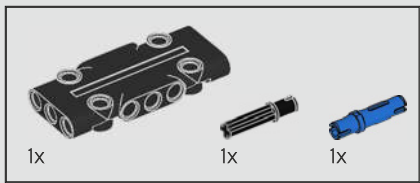

339

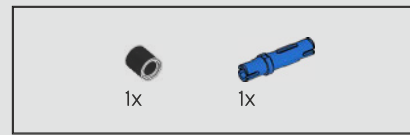
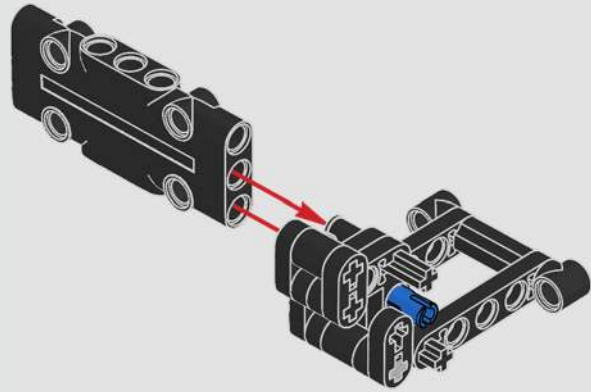

340

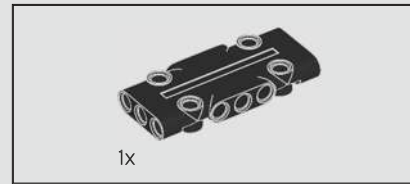
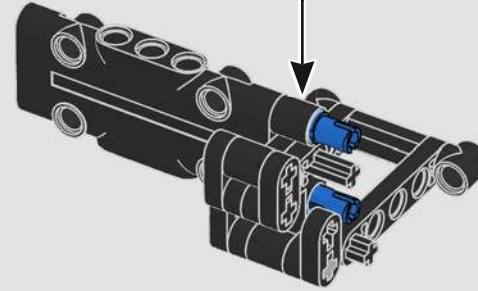

341

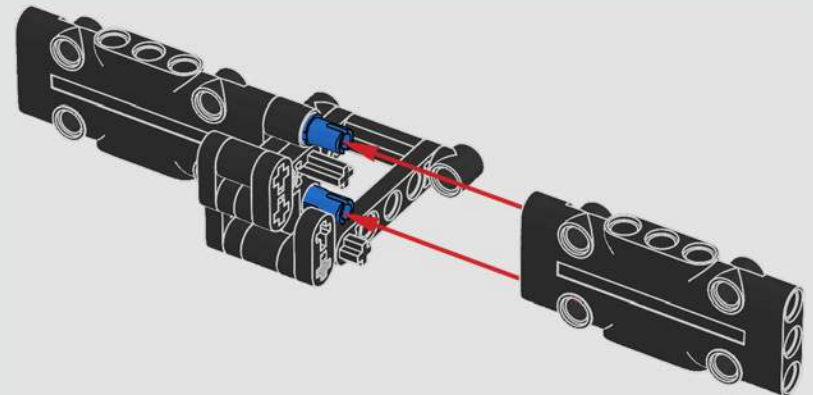



342

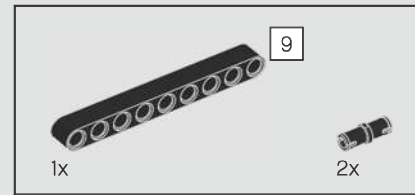
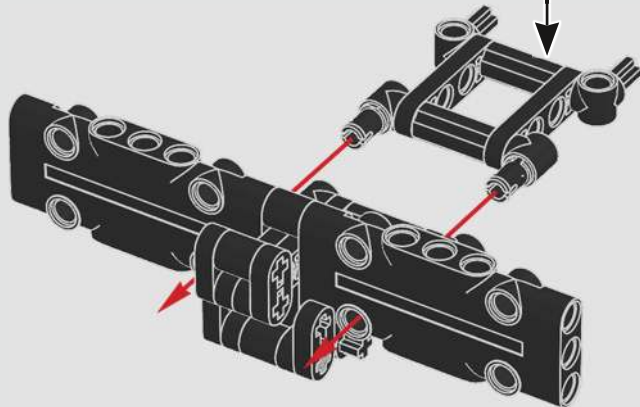
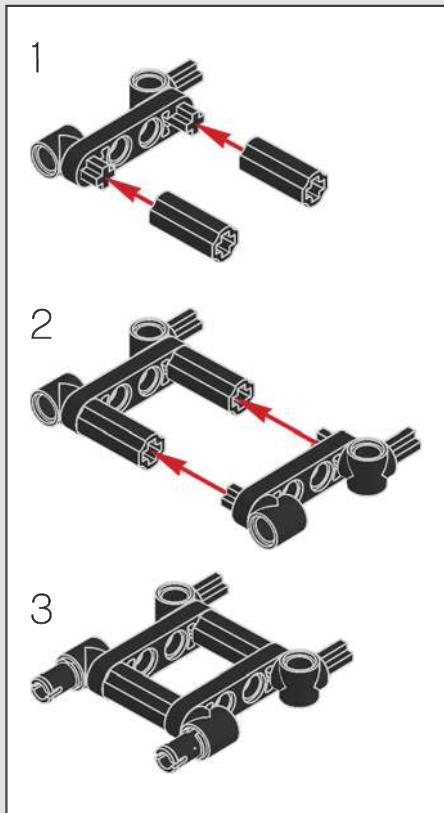
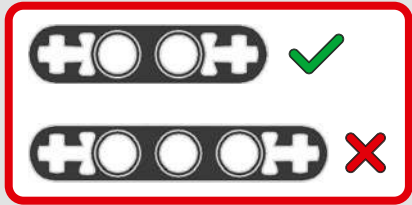

343

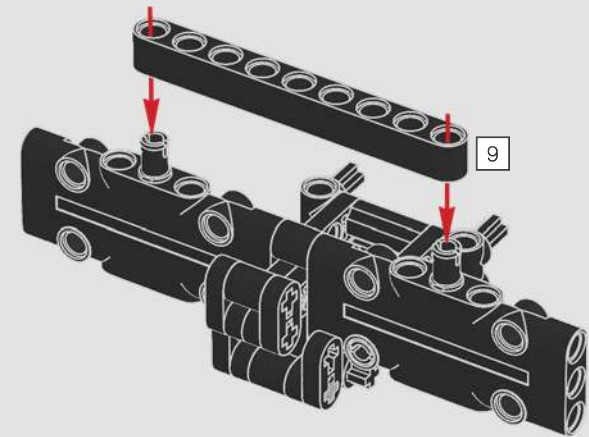

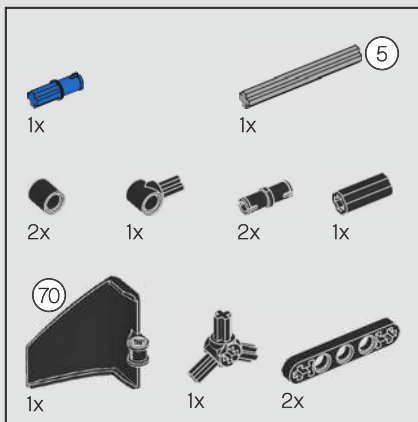

344

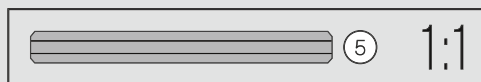
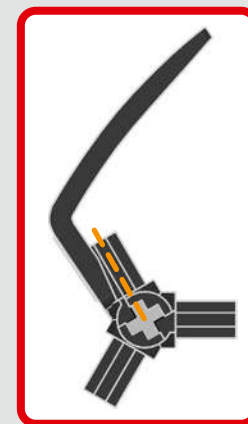
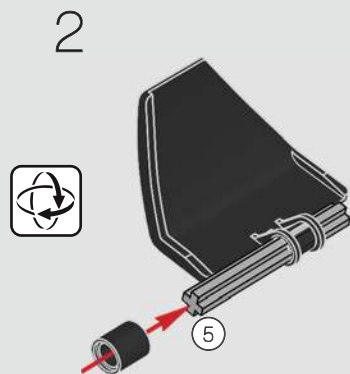
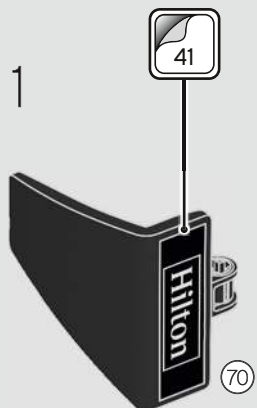

4

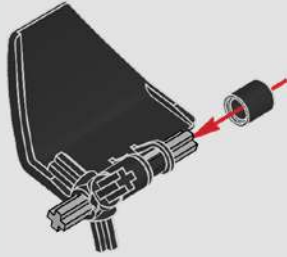

5

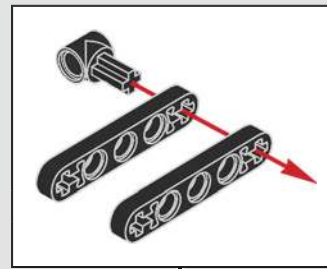
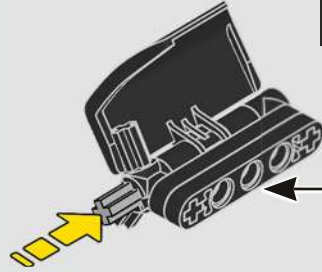

6

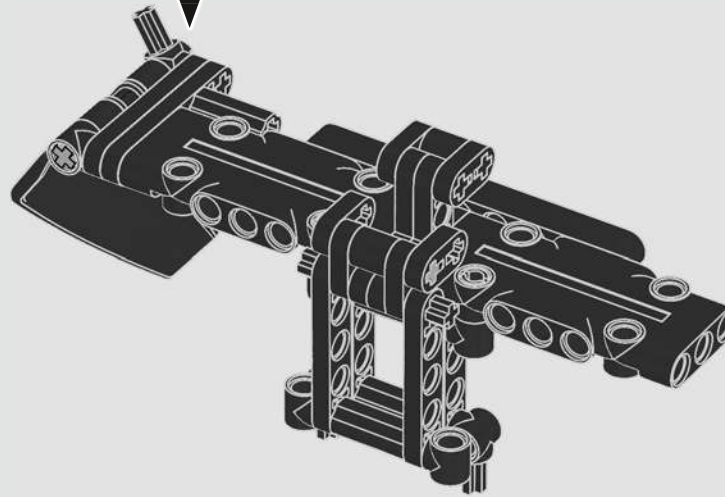
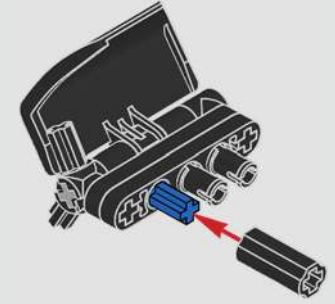

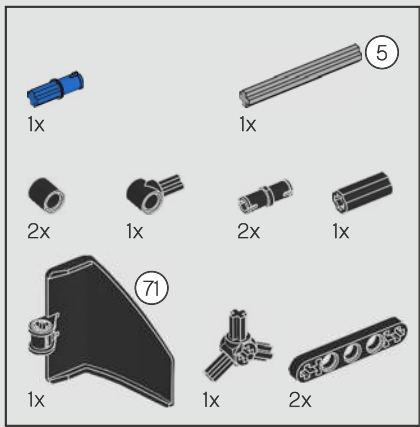

345

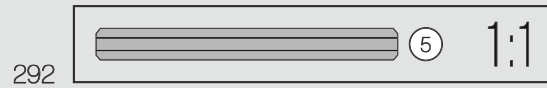
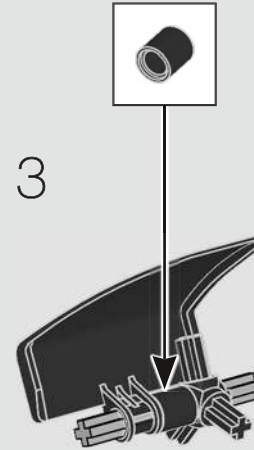
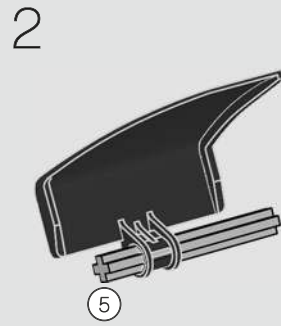
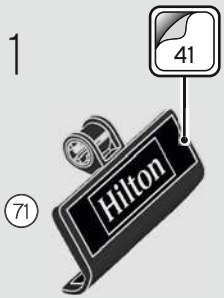

4

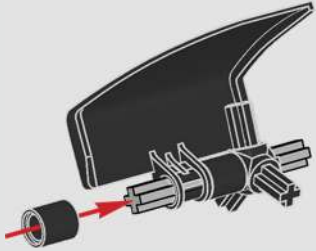

5

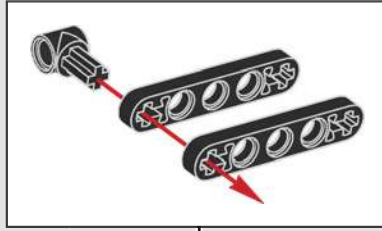
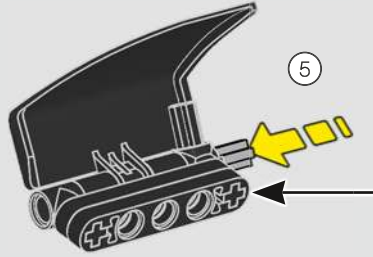

6

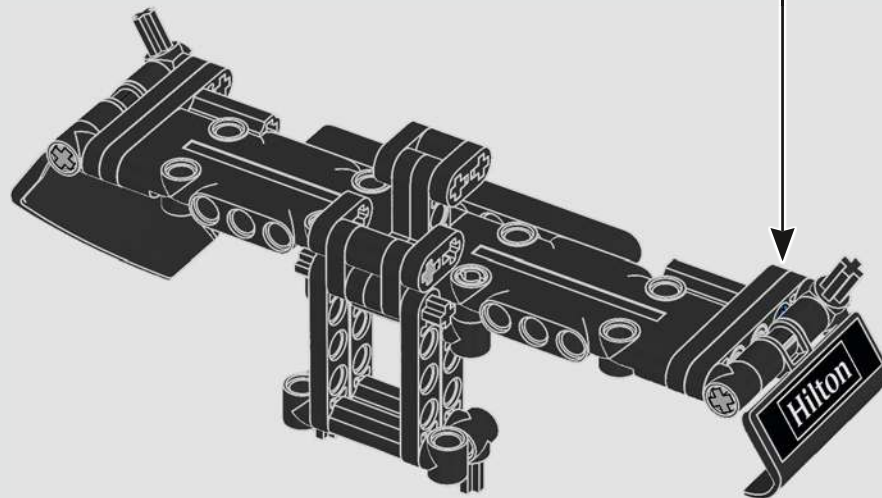
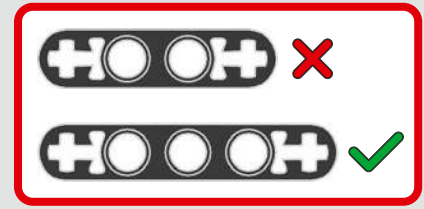
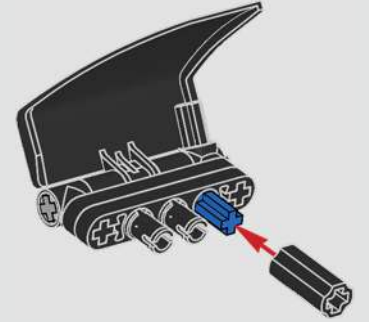



2x

346

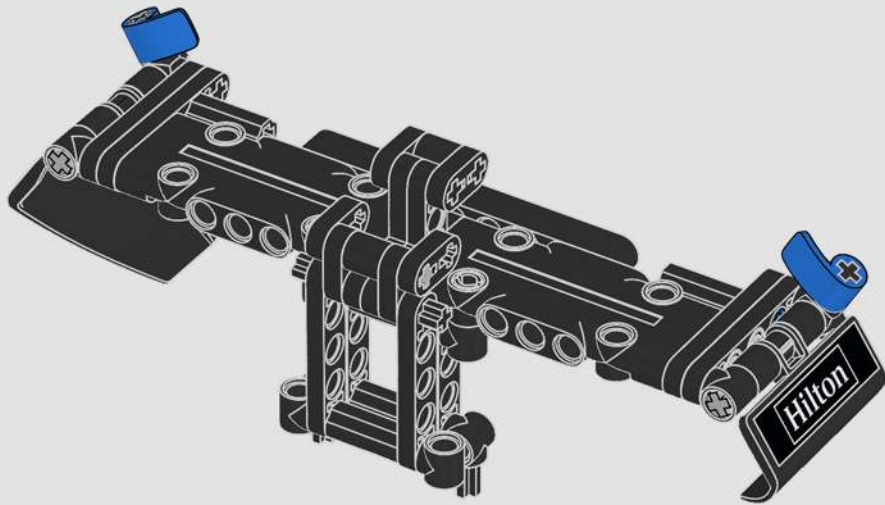

2x



2x



2x

347

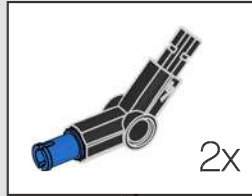

2x

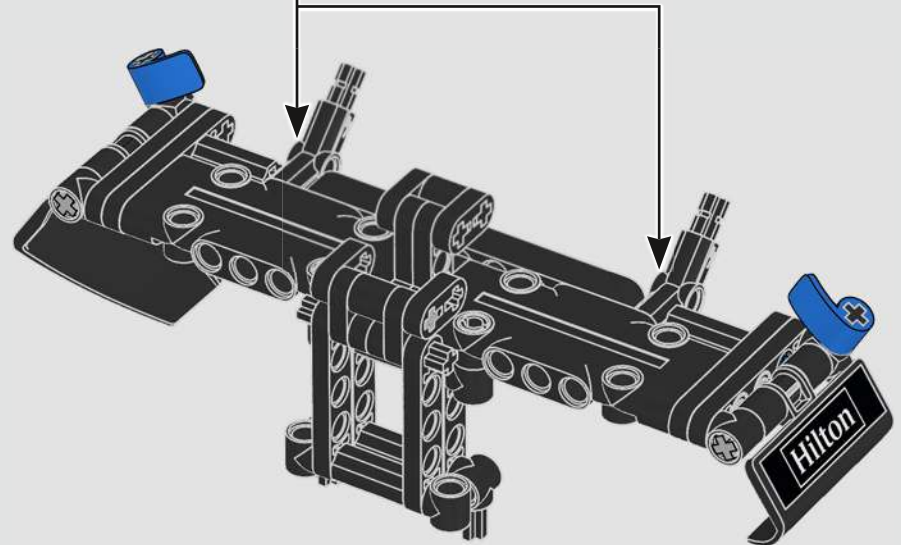

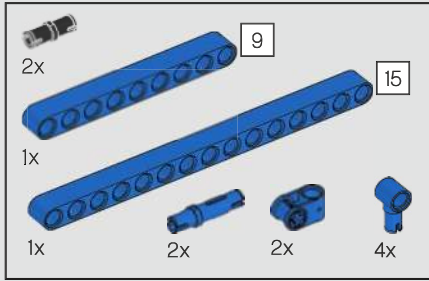

348

1

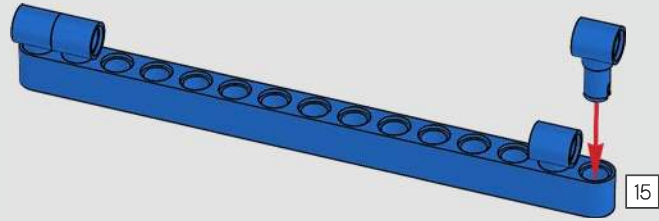

2

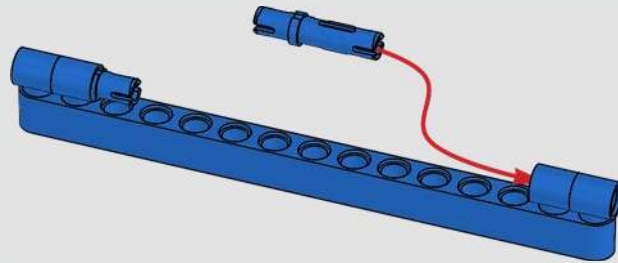

3

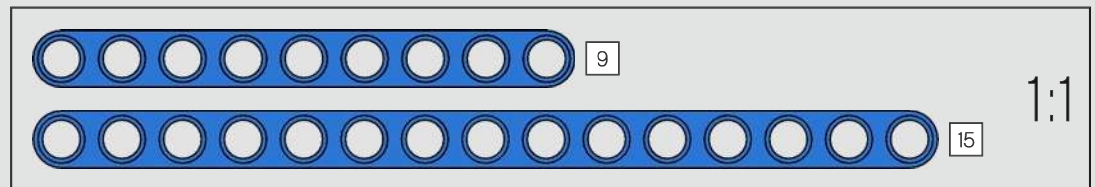
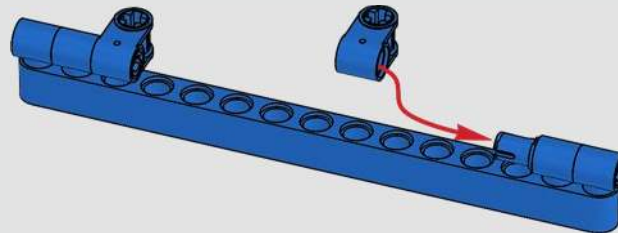

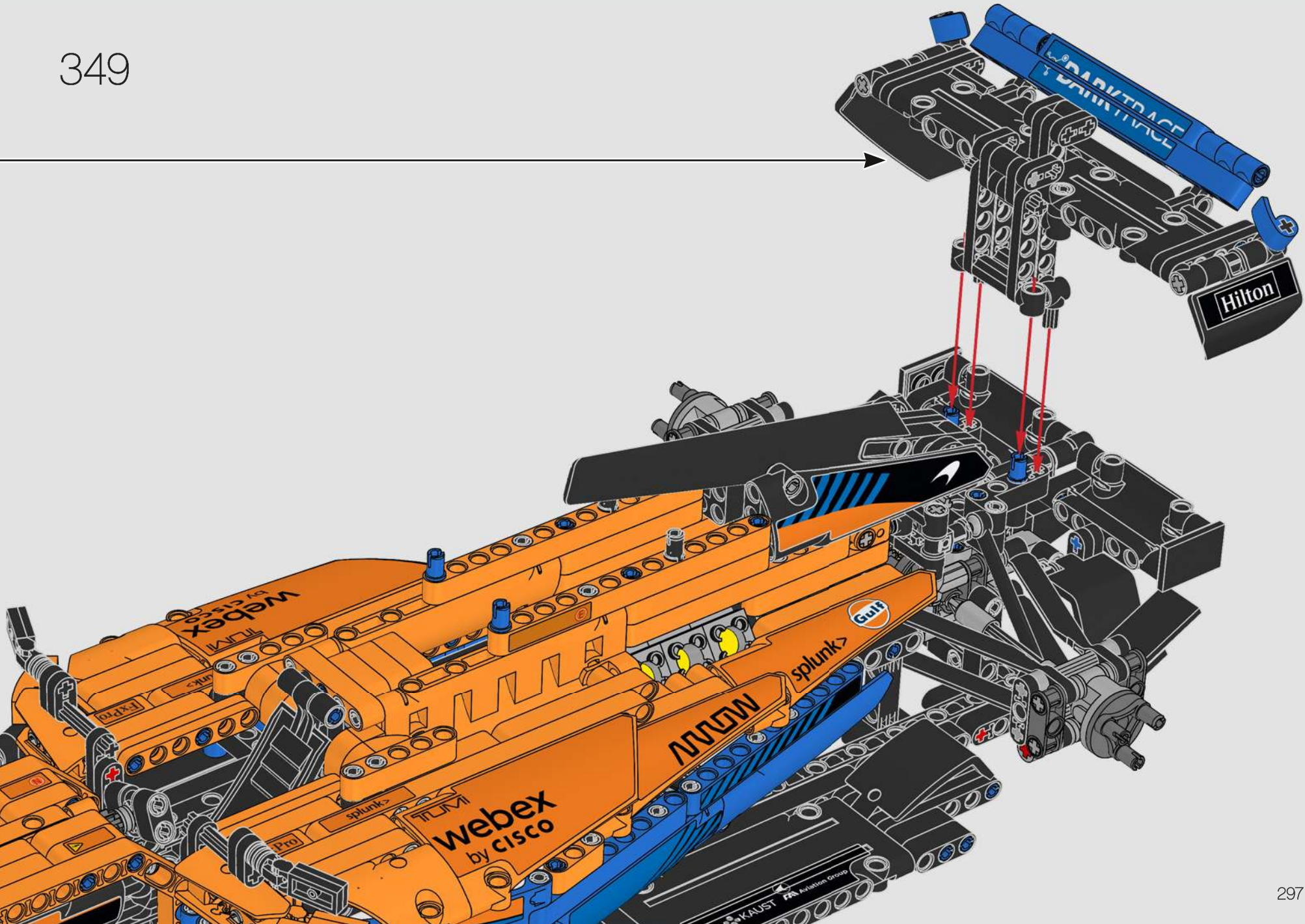

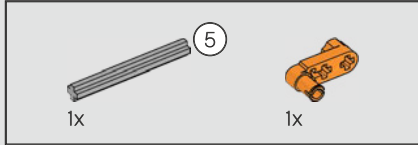
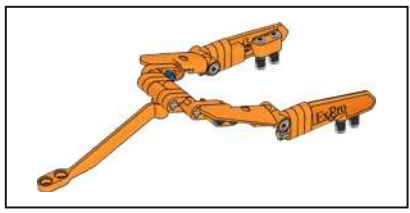

350

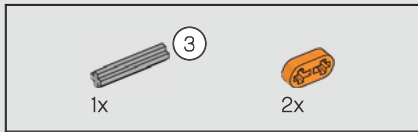
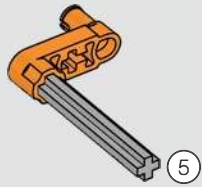

351

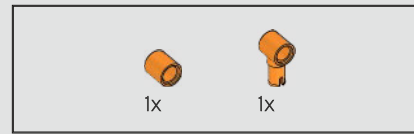
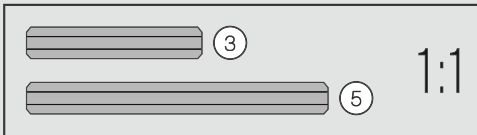
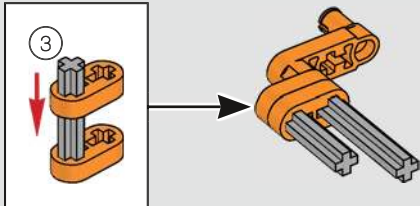

352

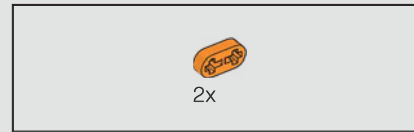
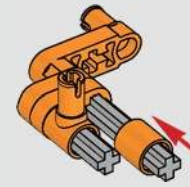
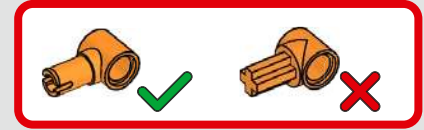

353

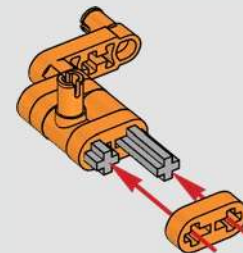

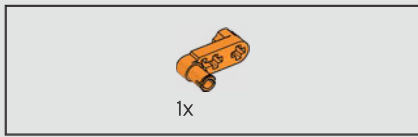

354

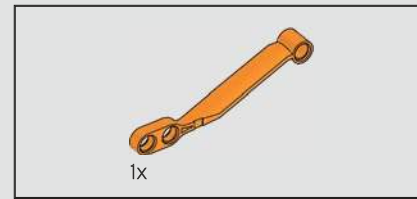
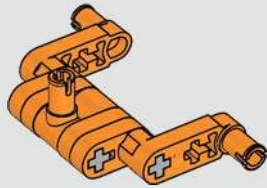

355

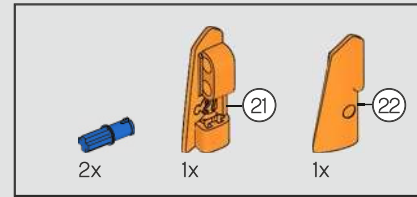
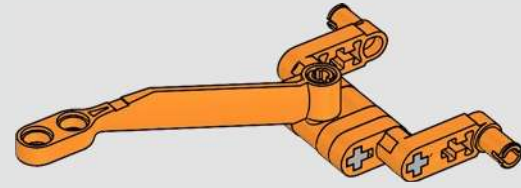

356

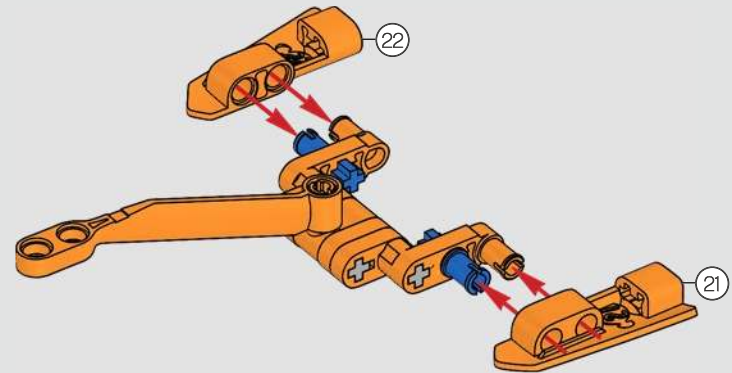

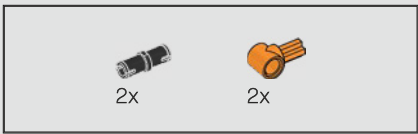

357

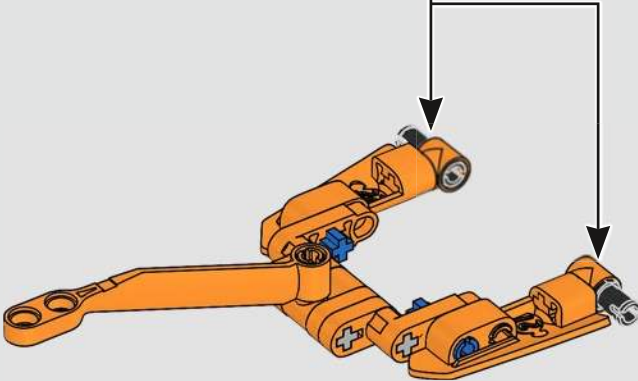
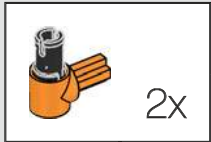

358

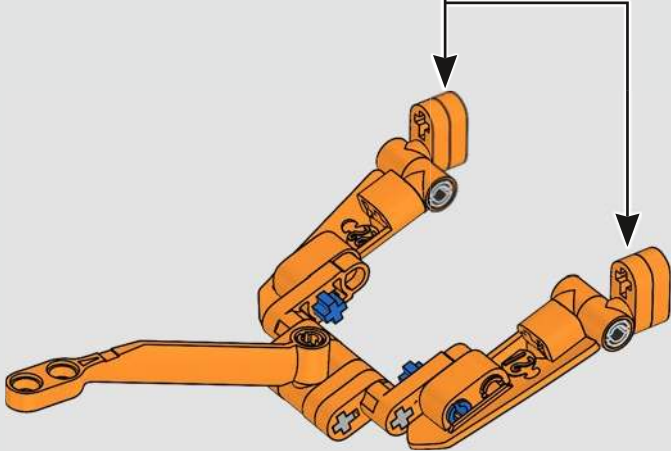
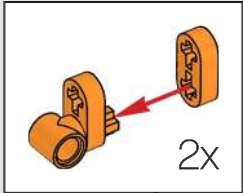

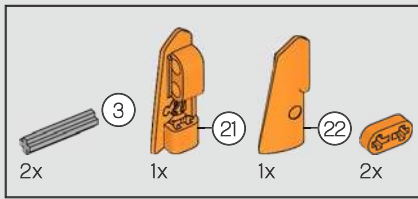

359

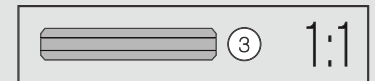
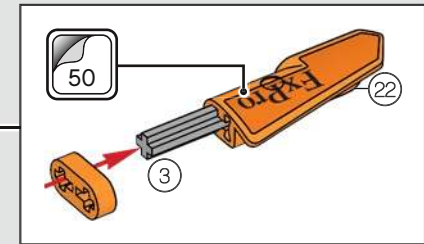
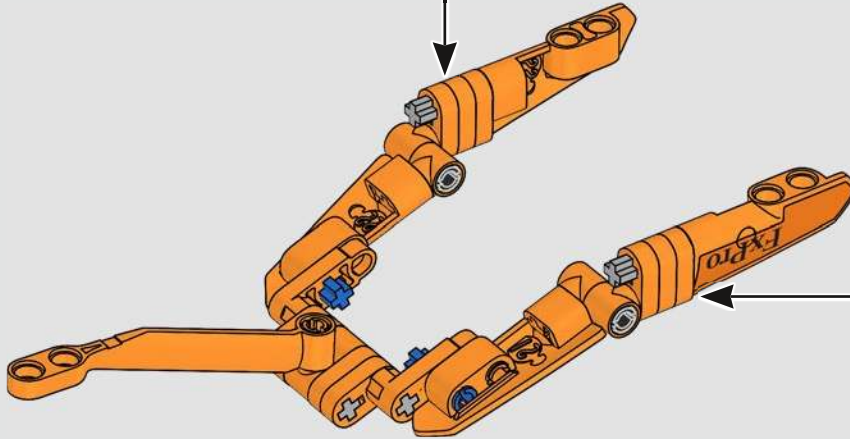
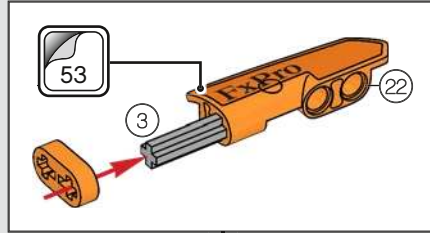



4x

360

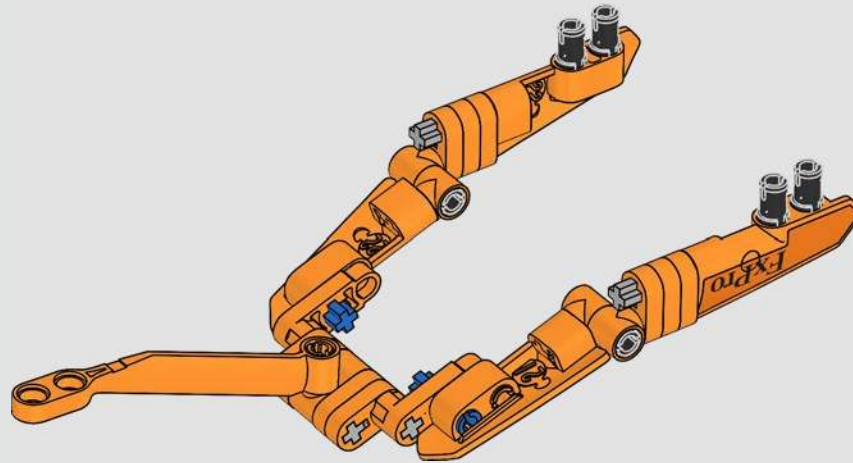

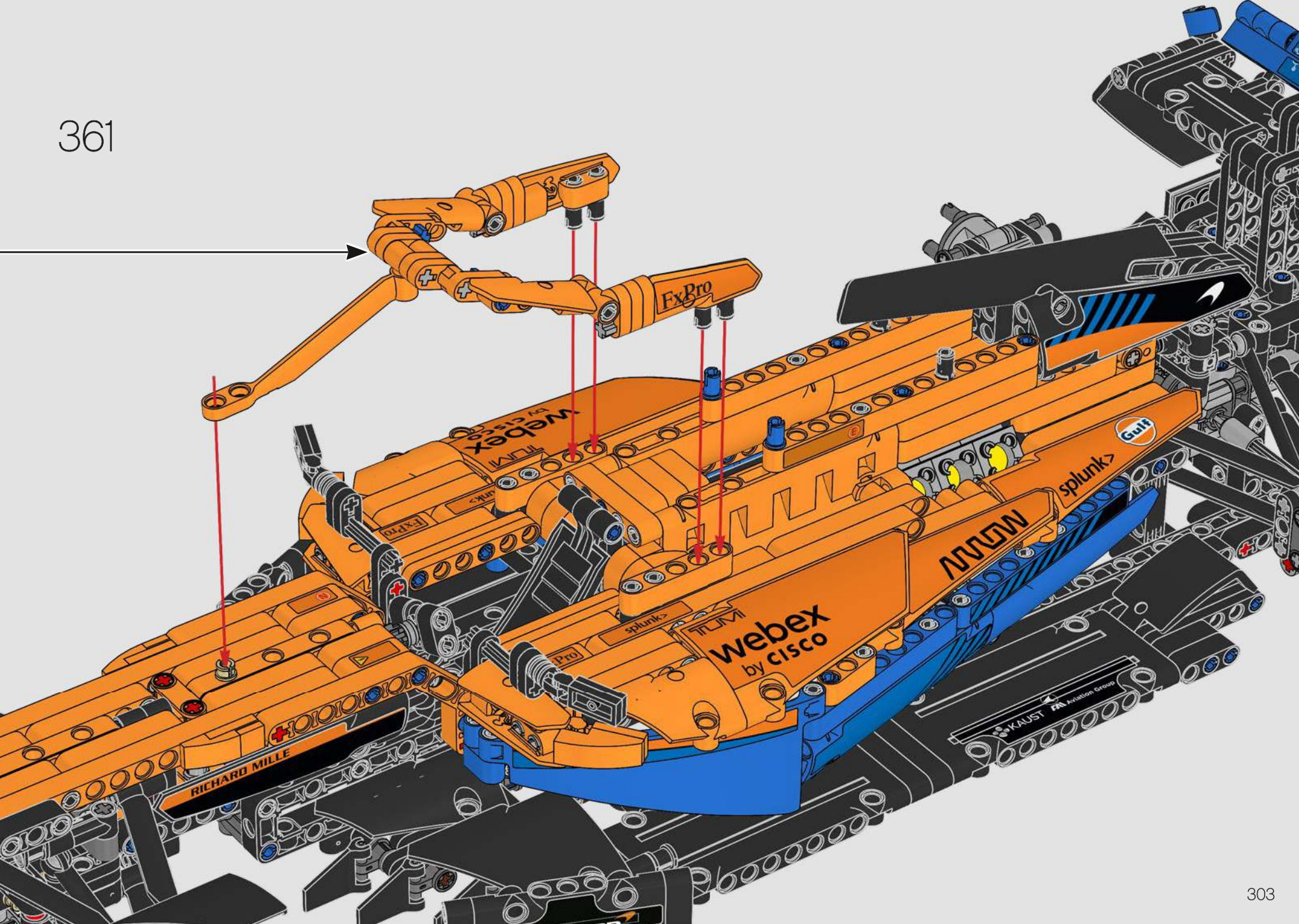

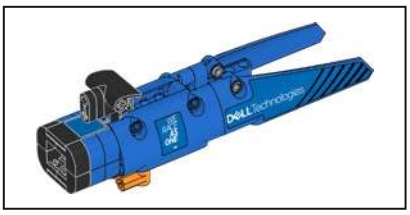

362



363



364



365

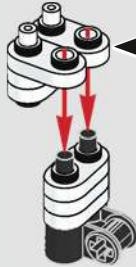
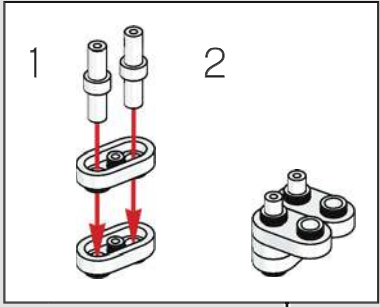

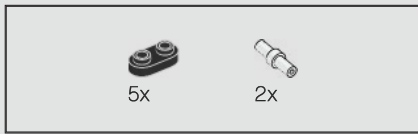

366

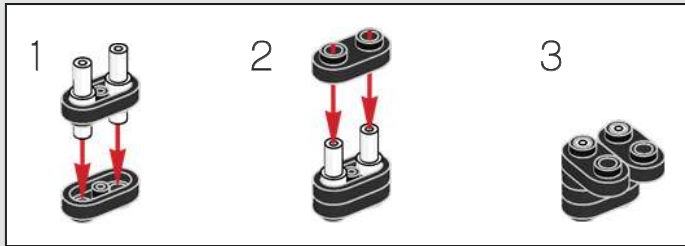

367

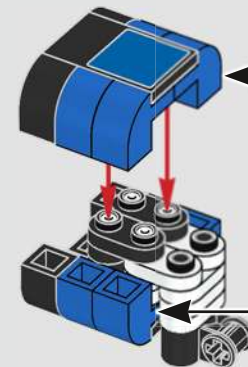
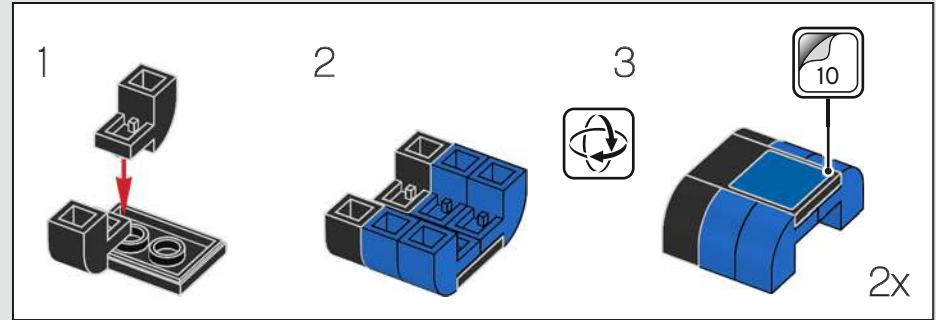

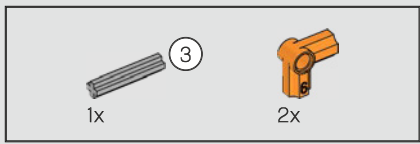

368

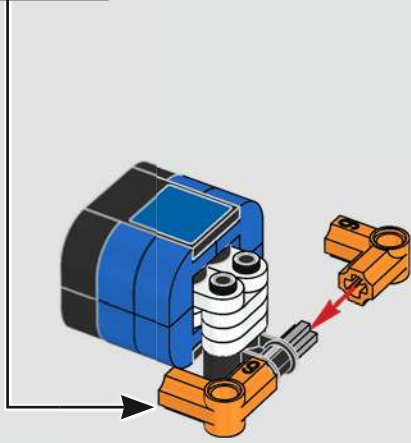
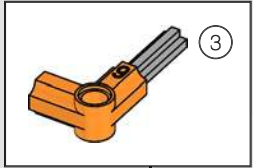

369

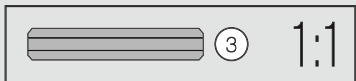
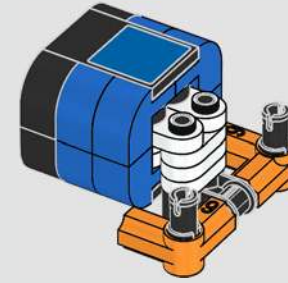

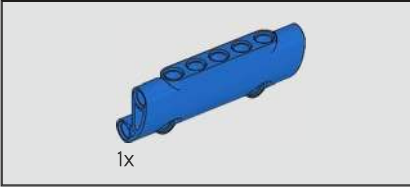

370

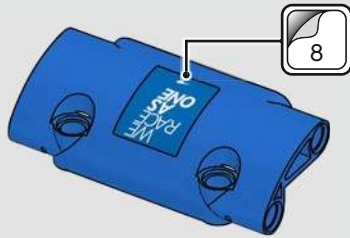

371

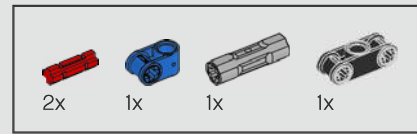
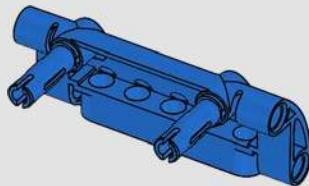

372

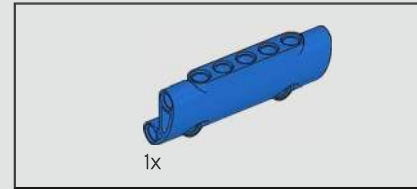
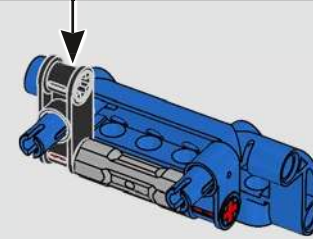
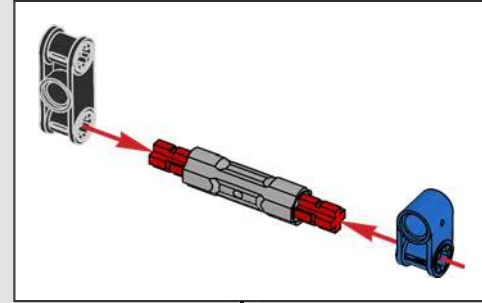

373

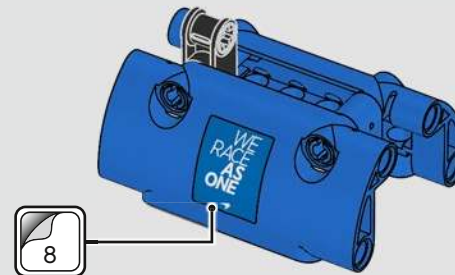



4x

374

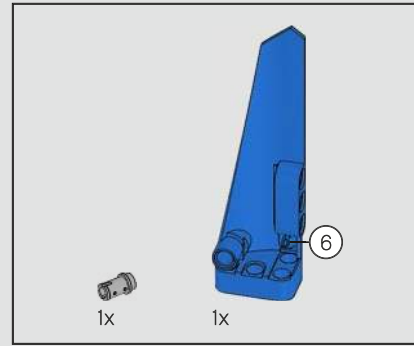
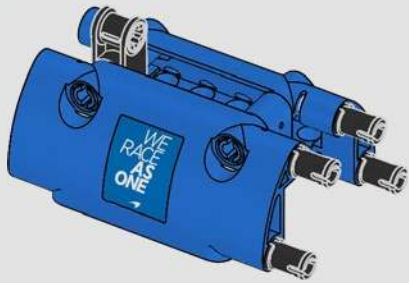

375

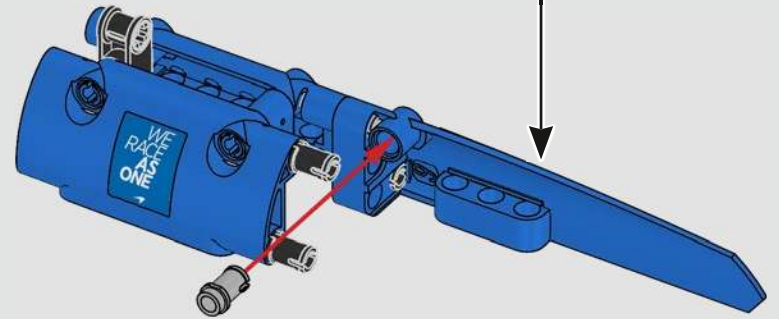

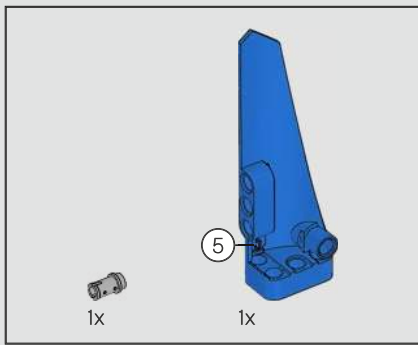

376

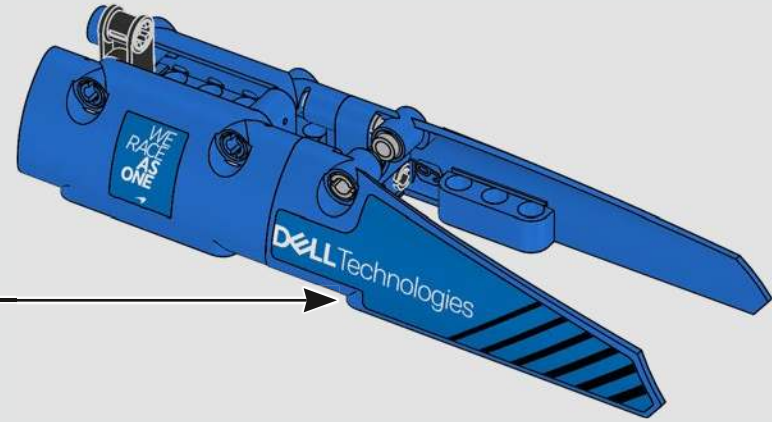
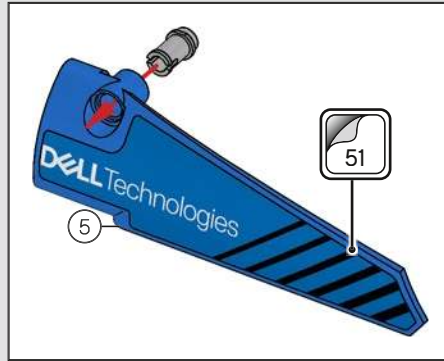

377

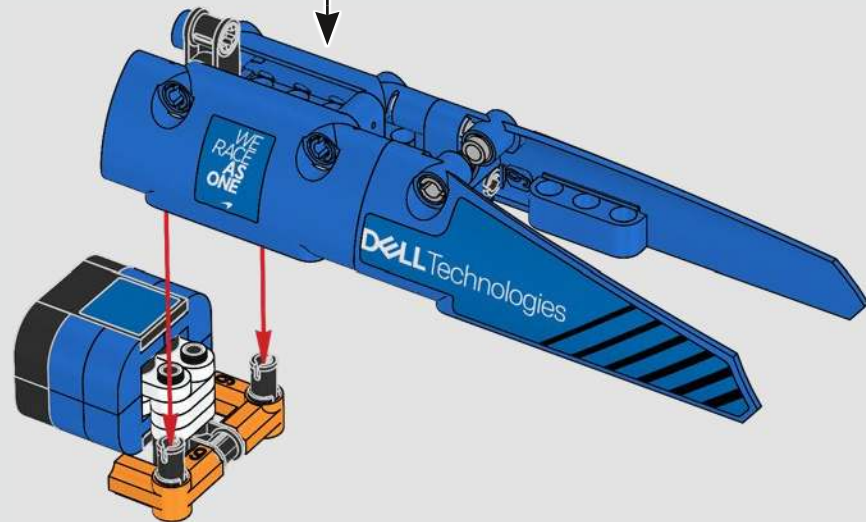

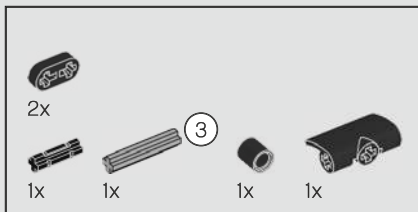

378

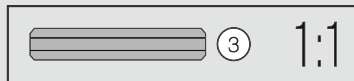
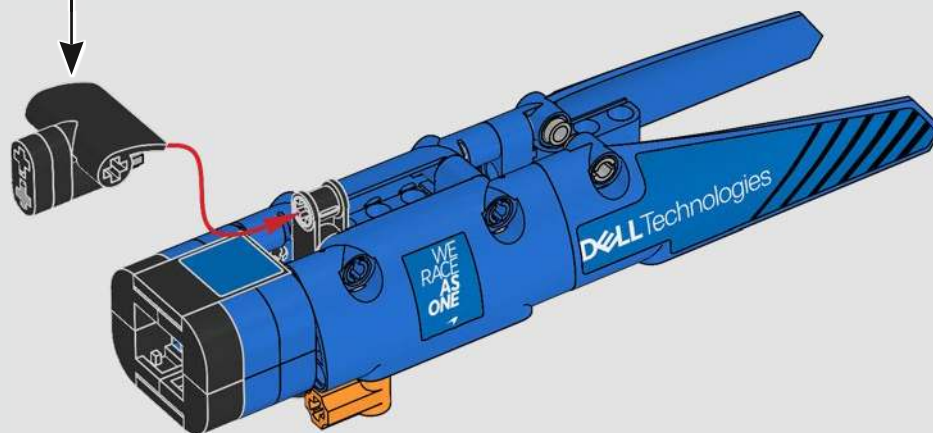
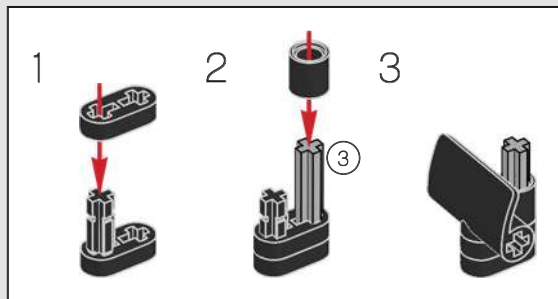

379

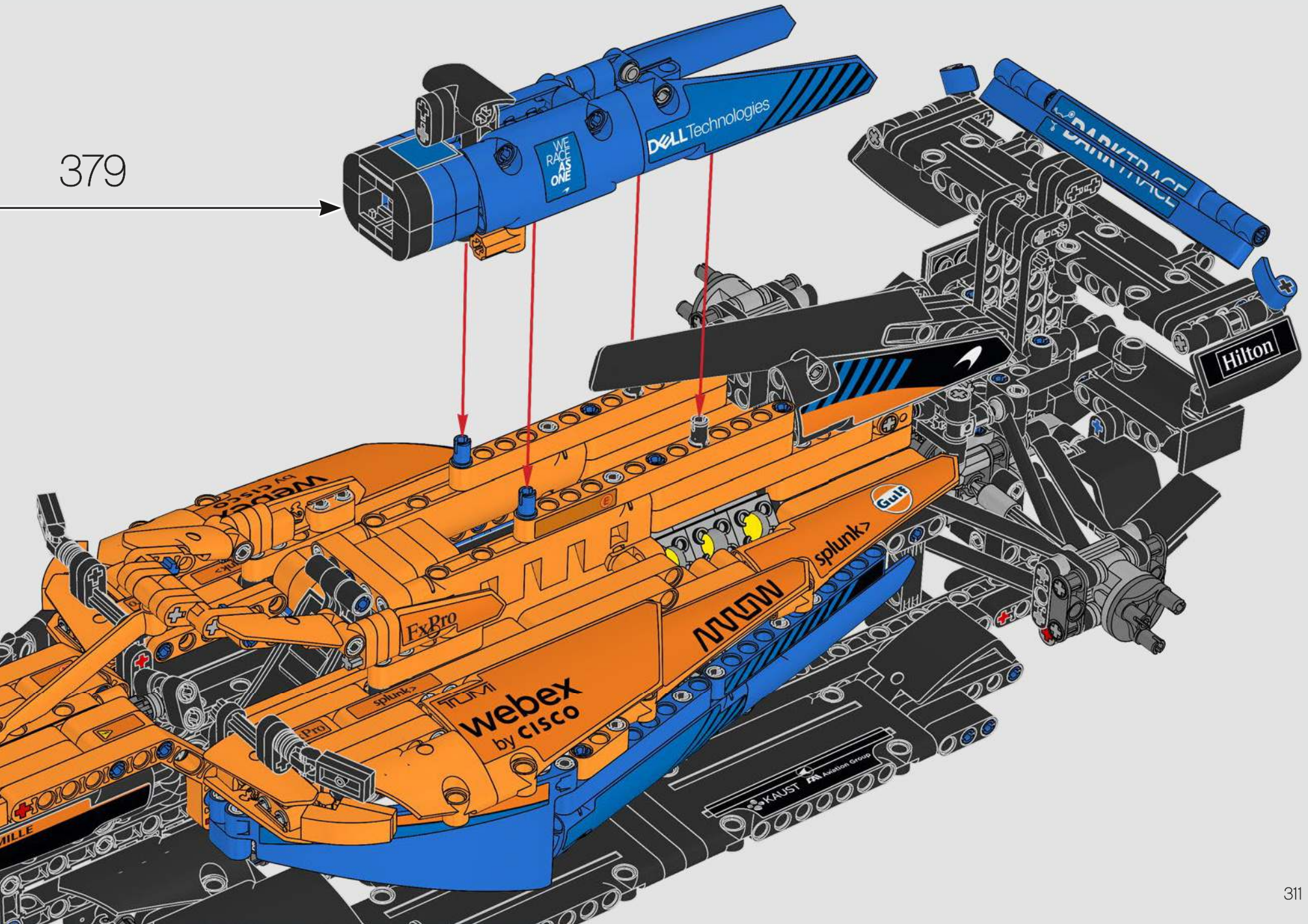

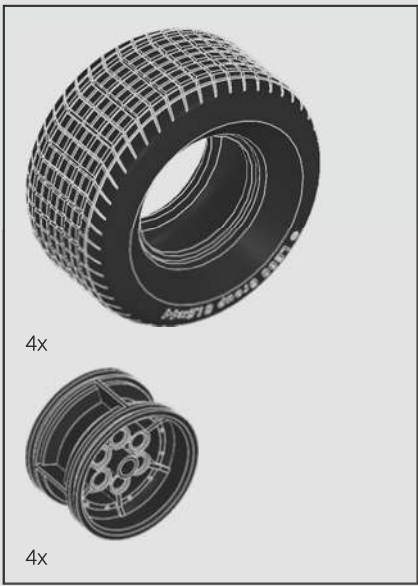

380

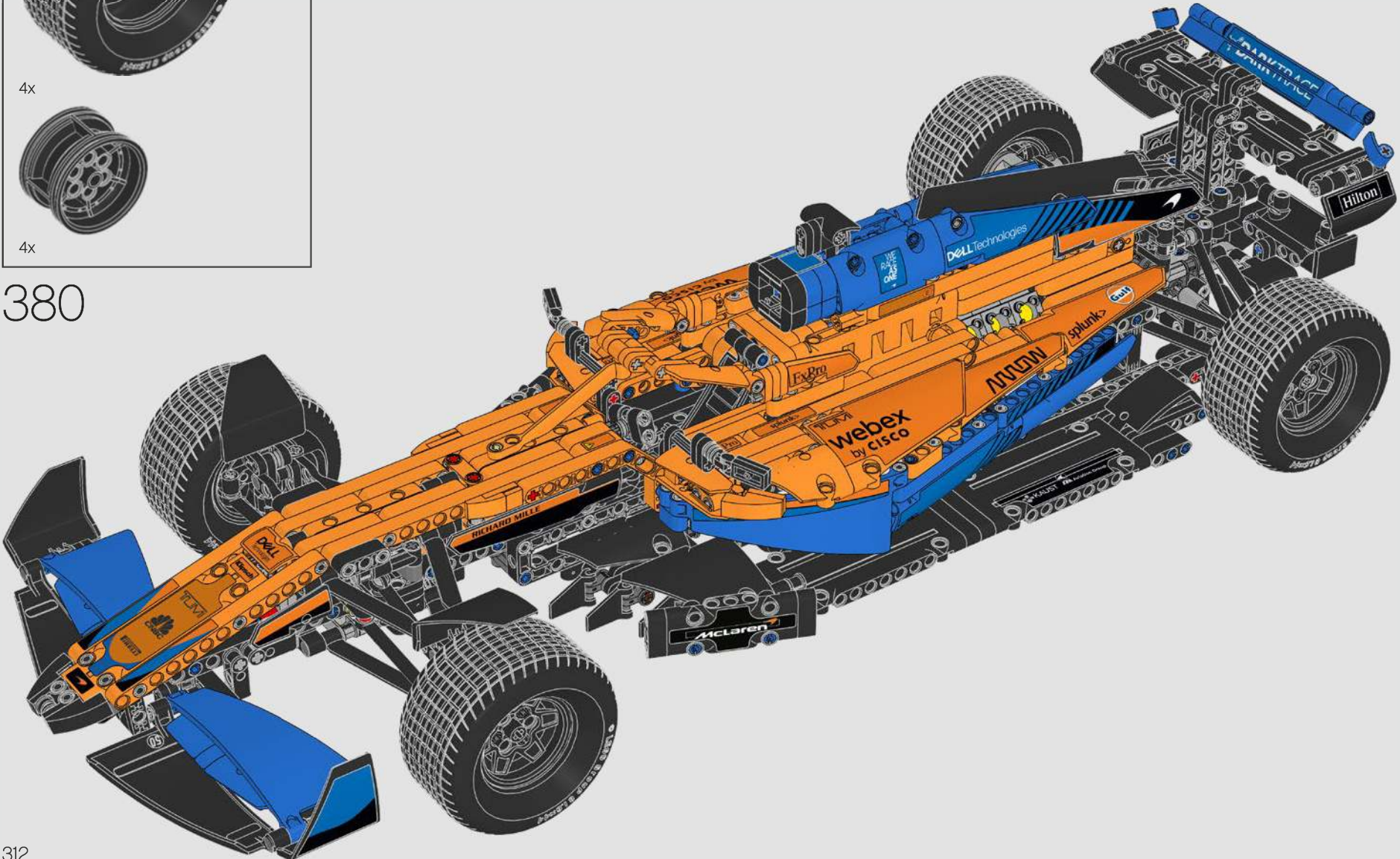

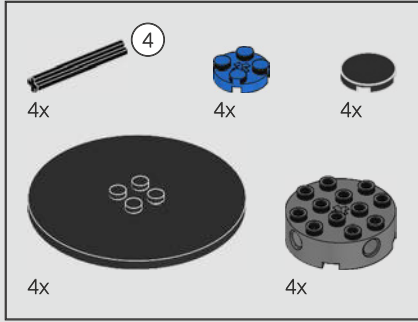
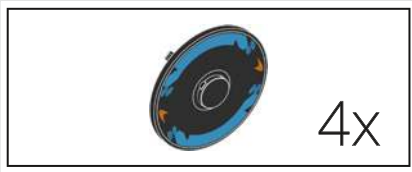

381

1

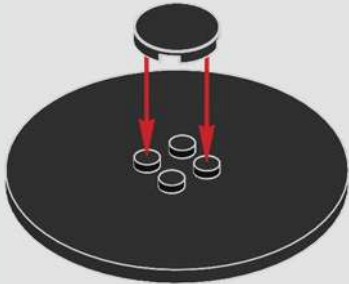

2

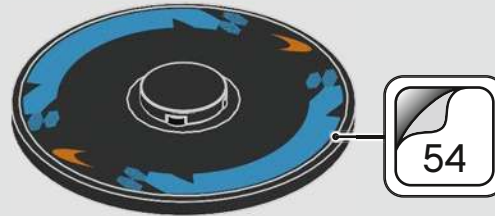

3

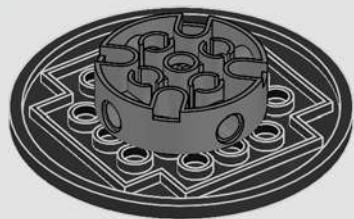

4

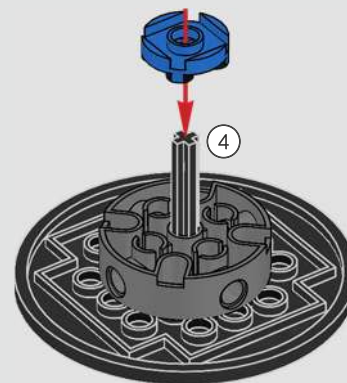

4x

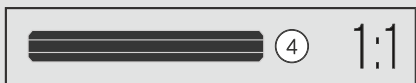

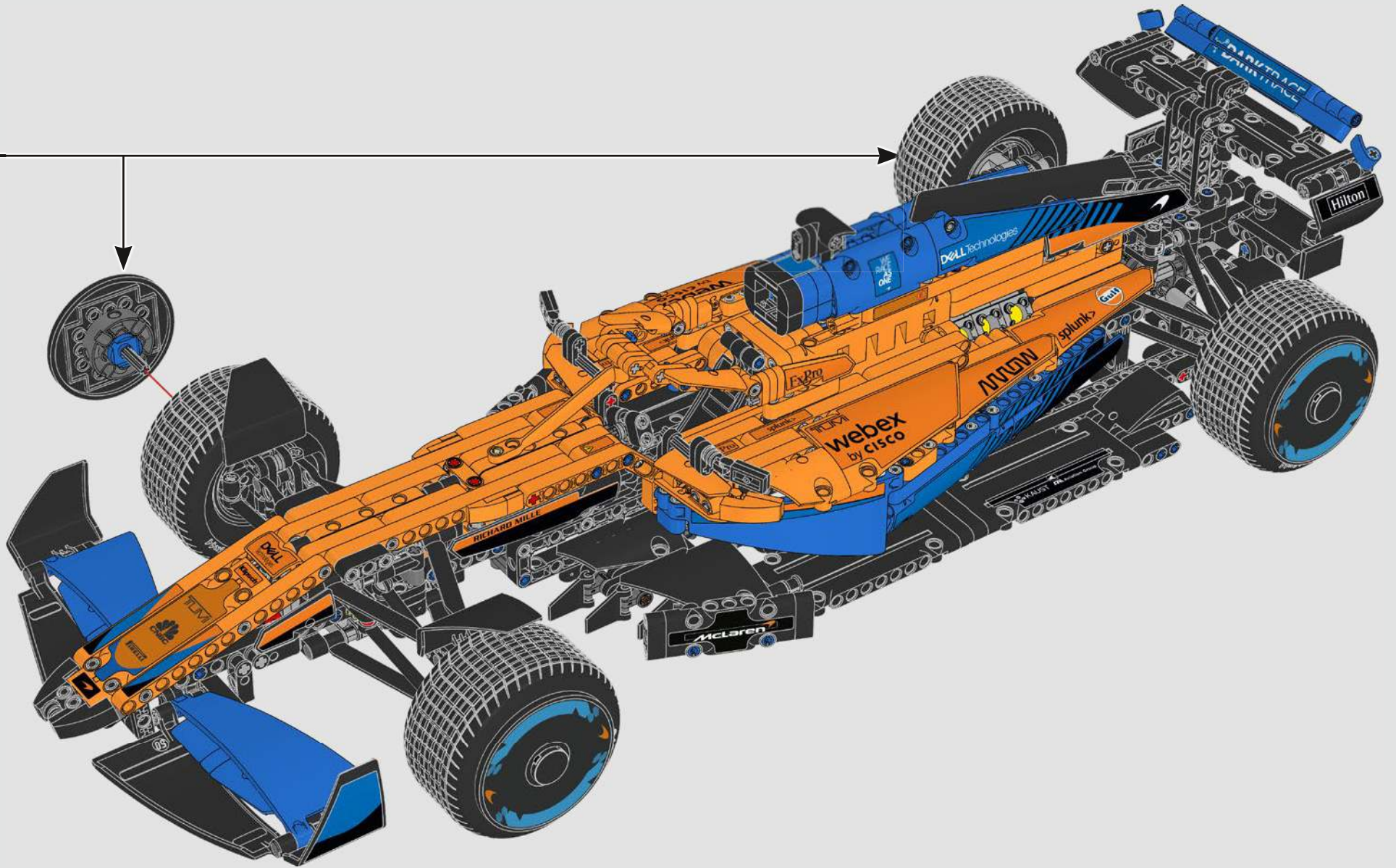



FEEDBACK AND WIN



FEEDBACK AND WIN

Your feedback will help shape the future development of this product series.

Please visit:

FEEDBACK UND GEWINNEN

Dein Feedback trägt zur Weiterentwicklung dieser Produktreihe bei.

Geh auf:

COMMENTEZ ET GAGNEZ

Vos commentaires nous aideront à concevoir les futurs produits de cette gamme.

Rendez-vous sur :

COMENTA Y GANA

Tu opinión nos ayudará a dar forma al desarrollo de esta serie de productos en el futuro.

Visita:

反馈有奖

您的反馈将有助于我们在今后改进本系列产品。

请访问：

[LEGO.com/productfeedback](https://www.lego.com/productfeedback)

By completing, you will automatically enter a drawing to win a LEGO® set.

Terms & Conditions apply.

Durch Ausfüllen nimmst du automatisch an der Verlosung eines LEGO® Preises teil.

Es gelten die Teilnahmebedingungen.

En envoyant vos commentaires, vous serez automatiquement inscrit(e) à un tirage au sort qui vous permettra de remporter un prix LEGO®.

Offre soumise à conditions.

Al contestar, participarás automáticamente en el sorteo y podrás ganar un set LEGO®.

Sujeto a Términos y Condiciones.

完成我们的反馈调查，即可自动进入抽奖环节，赢取乐高®套装。

适用《条款和条件》。

- 4x 6357680
- 7x 6210272
- 4x 6265135
- 2x 6001831
- 3x 4565452
- 3x 6013938
- 2x 6355727
- 1x 6346517
- 2x 6378120
- 2x 6323573
- 6x 6360104
- 13x 4142865
- 17x 6209519
- 2x 6347789
- 5x 6129995
- 1x 6352661
- 4x 6385238
- 3x 6261383
- 1x 6352643
- 4x 403223
- 43x 4206482
- 3x 6057802
- 8x 4189123
- 119x 6299413
- 2x 6330920
- 2x 6331025
- 8x 6282145
- 2x 6330921
- 2x 6391882
- 3x 6115617
- 2x 6390388
- 2x 6390387
- 2x 6390394
- 2x 6390392
- 2x 6390392
- 1x 6057799
- 6x 4112203
- 2x 4119474
- 3x 6130009
- 2x 614126
- 25x 6121485
- 12x 6282140
- 1x 4177431
- 5x 6210270
- 2x 6265699
- 1x 6319983
- 2x 4143187
- 38x 6338428
- 3x 6261371
- 1x 6316923
- 15x 6284699
- 268x 6279875
- 13x 4109810
- 4x 6070695
- 6x 6253260
- 6x 6099801
- 1x 6265091
- 2x 4177444
- 5x 4512363
- 2x 6280394
- 8x 6331716
- 4x 6383142
- 1x 6178922
- 4x 6192309
- 2x 306926
- 8x 6173119
- 1x 446026
- 2x 6271346
- 6x 6363033
- 2x 6390386
- 2x 6313520
- 2x 6093525
- 24x 6331723
- 2x 6262897
- 6x 6271810
- 14x 6273708
- 1x 6315899
- 14x 6089119
- 2x 6267045
- 13x 6321745
- 1x 6276951
- 7x 4552347
- 8x 4142822
- 8x 6271869
- 3x 6362991
- 2x 4251161
- 2x 4558731
- 2x 6352693
- 1x 6331026
- 4x 6327548
- 1x 4541325
- 2x 4558774
- 4x 6162892
- 1x 4541924
- 10x 370526
- 10x 6271825
- 12x 6327028
- 3x 6362555
- 8x 4142135
- 6x 4142823
- 4x 6390379
- 2x 6256116
- 2x 6271358
- 8x 6163980
- 4x 6162892
- 1x 4558740
- 1x 4558775
- 2x 370626
- 4x 6268012
- 1x 6327430
- 3x 6362554
- 2x 6318582
- 5x 4495935
- 4x 6276858
- 16x 6389430
- 2x 6150082
- 4x 6331935
- 6x 6244698
- 4x 4645732
- 2x 6271152
- 4x 4205860



2x
6029578

11

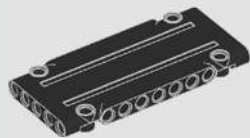

4x
4566243



1x
370826

12



50



1x
6080356



1x
6390391

15



4x
6199832



8x
4542573



1x
6208345

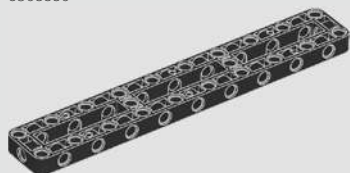

1x
6305550

2x
6377025



51



4x
4522933

13

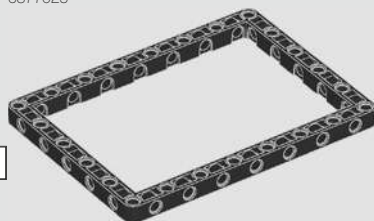

2x
6295161

1x
6254248



4x
6027566

1x
6390380



1x
6390390



4x
4558595



4x
6352662



10x
6390384



6x
6261377



4x
6340604



4x
6391881



10x
6265128



2x
6390383



4x
4177932



4x
6055069



4x
6112356



2x
6266212



2x
6391883



2x
6390385



2x
4542142



2x
6390382



11x
6102618



2x
4251969



6x
6358253



1x
6135080



10x
6339024



1x
6135079



1x
6370444



1x
6370445



1x
6358255



2x
6271162



2x
6390599



2x
6358254



18x
6143014



2x
6135085



4x
6390381



18

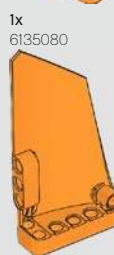

17



7

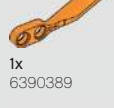
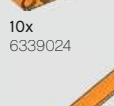

5



11

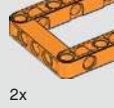

5

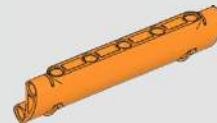

2x
4580022

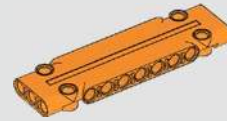

1x
6339023

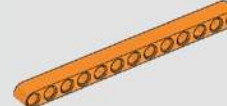

15



6x
4629802

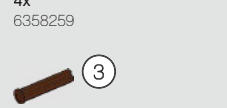

4x
6358259



2x
6135494

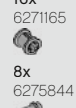

4x
6265690

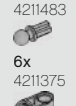

16x
6271165



8x
6275844



26x
4211483

6x
4211375

3x
6261375

2x
6296859

8x
4211807



8x
4512360



6x
6000018



2x
6169984



29x
4211815



3x
6276969



2x
6346487



1x
6282158



7x
6331441



6x
6273212



4x
6370947



6x
4234251



4x
6331574

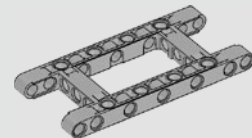

1x
4540797

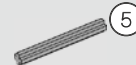

19x
4211639



2x
6170293



2x
6012451



6x
6265669



4x
6135014



2x
4610374



1x
6167281



15x
6276984



2x
4508553

5



2x
6271876



6x
4210751



4x
4610378



24x
6083620



4x
4211097



1x
4525184



5.5

Customer Service
Kundenservice
Service Consommateurs
Servicio Al Consumidor
LEGO.com/service or dial



: 00800 5346 5555
: 1-800-422-5346

