

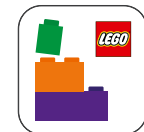

10298



Booklet available in English on
Heft in deutscher Sprache erhältlich auf
Livret disponible en français sur
Libretto disponibile in italiano su
Folleto en español disponible en
如需中文版手册, 请访问



LEGO® Builder

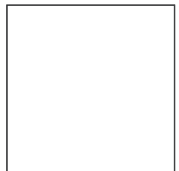



CELEBRATING AN ICON

Born in Pontedera, Italy, in 1946, the Vespa was the perfect symbol of a bright new future. It quickly became more than just a means of transport, representing both the joy of living and modern fashion. With more than 75 years on the road, we thought it was the perfect time to celebrate this cultural icon and hope you'll enjoy building the LEGO® version of this classic vehicle.

CELEBRAZIONE DI UN SIMBOLO

Nata a Pontedera nel 1946, la Vespa divenne il simbolo perfetto di un nuovo e brillante futuro. Rapidamente fu ben più di un semplice mezzo di trasporto, rappresentando gioia di vivere e stile. Con più di 75 anni sulla strada, ci sembrava il momento giusto per celebrare questa icona che ha saputo diventare un fenomeno culturale, e speriamo che ti divertirai a costruire la versione LEGO® di questo veicolo che è un classico senza tempo.



THE VESPA 125

Introduced in 1960, the Vespa 125 captured the care-free spirit of the decade, offering affordable style and mobility to a new youthful generation. Then as now, colour has always played an important role, ensuring the Vespa's status as fashion icon. This pastel blue tone was also very much of its time and was the only colour the 125 was available in when it launched.

LA VESPA 125

Introdotta nel 1960, la Vespa 125 ha interpretato lo spirito spensierato del decennio che stava iniziando, offrendo stile e mobilità a prezzi accessibili alle nuove generazioni. Allora come oggi, il colore ha sempre avuto un ruolo importante, garantendo a Vespa lo status di icona di stile. Questa particolare tonalità di blu pastello era molto popolare all'epoca ed era l'unico colore in cui la 125 era disponibile quando fu lanciata.

The Vespa's story has been long and successful, crossing borders and oceans, taking Italian style to the roads all over the world for over 75 years.

La storia di Vespa è lunga e piena di successi, ha attraversato confini e oceani, portando lo stile italiano sulle strade di tutto il mondo da oltre 75 anni.

Synonymous with performance and reliability, the Vespa GS became the queen of regularity rallies in the second half of the 1950s.

Sinonimo di prestazioni e affidabilità, la Vespa GS (Gran Sport) divenne la regina delle competizioni di regolarità nella seconda metà degli anni '50.



1954

The "Chi Vespa mangia le mele" ("He who Vespas eats apples") launch campaign for the new Vespa Primavera 125 marked a revolution in the world of advertising.



La campagna "Chi Vespa mangia le mele" per la nuova Vespa Primavera 125 rivoluziona il mondo della pubblicità.

1968

1946

On 23 April 1946, Piaggio filed the patent for a motorised vehicle with a 98cc single-cylinder 2-stroke engine. Vespa was born.

Il 23 Aprile 1946 Piaggio deposita il brevetto di uno scooter motorizzato con un monocilindrico 2T da 98 cc. Nasce Vespa.



1963



The Vespa 50cc became an instant success among young people, who could ride it without needing a driving licence.

La Vespa 50cc diventa subito un successo tra i giovani, che possono guidarla senza bisogno della patente.

With more than three million sold, the PX became the most successful Vespa model of all times.

Con oltre tre milioni di esemplari venduti, la PX diventa il modello Vespa di maggior successo di tutti i tempi.



1978



The GTS 250 continued the tradition of sporty Vespa. The body was widened in order to improve the room for rider, passenger and luggage.

La GTS 250 è l'erede della tradizione sportiva di Vespa. La carrozzeria è stata allargata per migliorare lo spazio per pilota, passeggero e bagagli.

2006

Vespa celebrates its 75th anniversary with the Vespa 75th special edition, reinforcing the brand's status as a fashion icon.

Vespa celebra il suo 75° anniversario con la serie speciale Vespa 75th, consolidando il suo status di icona di stile.



2021

With the 50 ET, Vespa entered the third millennium without losing its elegant, pleasant and instantly recognisable lines that have always distinguished it.

1996



Con la 50 ET, Vespa varca il terzo millennio senza perdere le linee eleganti, piacevoli e immediatamente riconoscibili che l'hanno sempre contraddistinta.

2019



With the Elettrica, you could negotiate the city streets in absolute silence, whether you opted for the Eco energy-saving mode or for the Power setting.

Con Vespa Elettrica puoi percorrere le strade della città in assoluto silenzio, sia che tu opti per la modalità di risparmio energetico Eco che per l'impostazione Power.



THE PERFECT NAME

Legend has it that when designer Corradino D'Ascanio presented his prototype to Enrico Piaggio, the manufacturer took one look at the vehicle's distinct body shape and antenna-like handlebars and exclaimed: "Sembra una vespa!" ("It looks like a wasp!"). When the sound of the engine was heard, it became even clearer that the perfect name had been found.

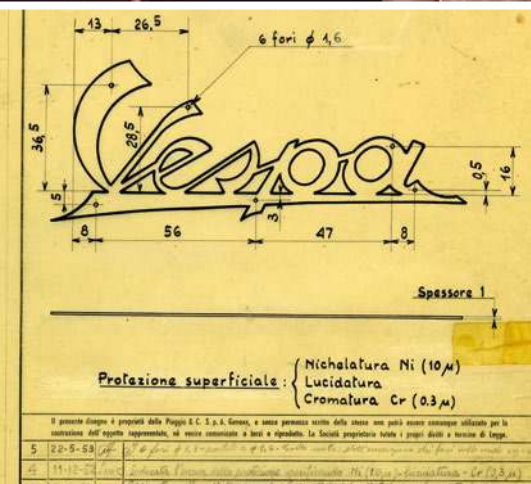

IL NOME PERFETTO

La leggenda narra che quando il progettista Corradino D'Ascanio presentò il suo prototipo a Enrico Piaggio, questi diede un'occhiata alla particolare conformazione del veicolo e al manubrio simile ad un'antenna ed esclamò: "Sembra una vespa!". Quando si udì il rombo del motore, divenne ancora più chiaro che era stato trovato il nome perfetto.

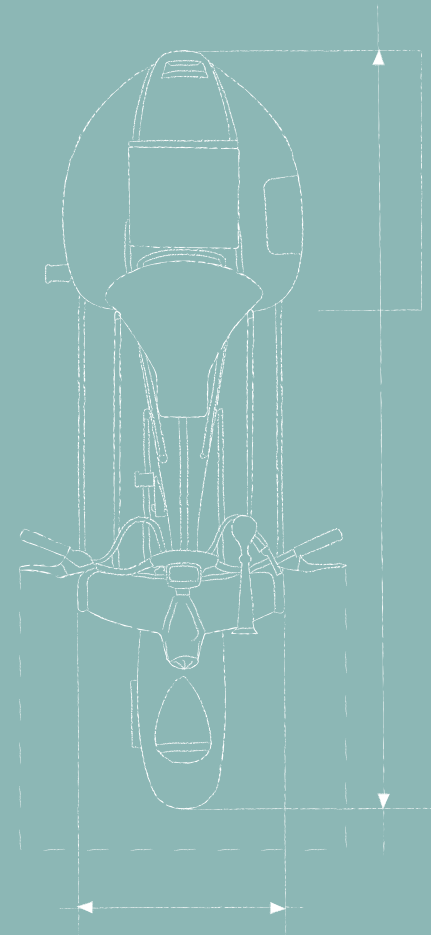
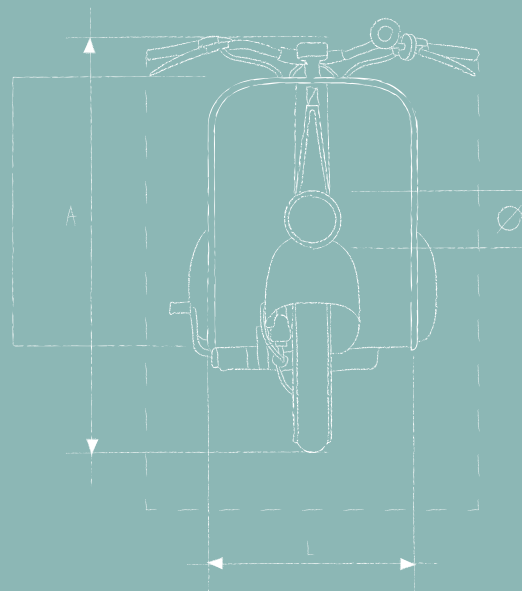

FROM THE DESIGN TEAM

"The biggest challenge for us was recreating the Vespa's organic rounded shapes in LEGO® elements. It took some time, but once this was achieved, we could start adding all those small but important details like the removable engine cover, kick-starter and pedals. Lastly, we worked on fun touches like the detachable flower basket and helmet with goggles to celebrate the iconic Dolce Vita feeling of the Vespa 125 from the mid-sixties."

Florian Müller, Senior Designer

IL DESIGN TEAM

"La sfida più grande è stata ricreare le forme arrotondate tipiche di Vespa con gli elementi LEGO®. Ci è voluto un po' di tempo, ma una volta raggiunto questo obiettivo, abbiamo potuto iniziare ad aggiungere piccoli ma importanti dettagli come il cofano motore rimovibile e il pedale di avviamento. Infine, l'abbiamo arricchita con tocchi divertenti come il cesto di fiori staccabile e il casco con gli occhiali, per celebrare l'iconica atmosfera della Dolce Vita anni Sessanta della Vespa 125."

Florian Müller, Senior Designer



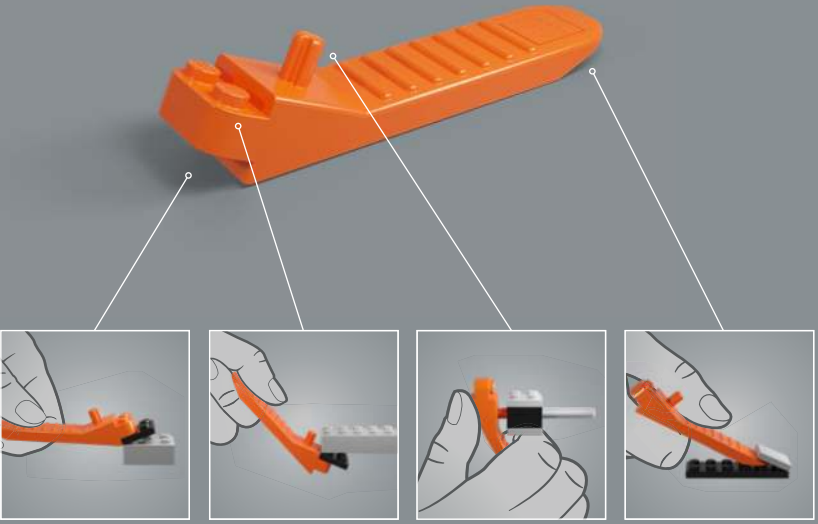
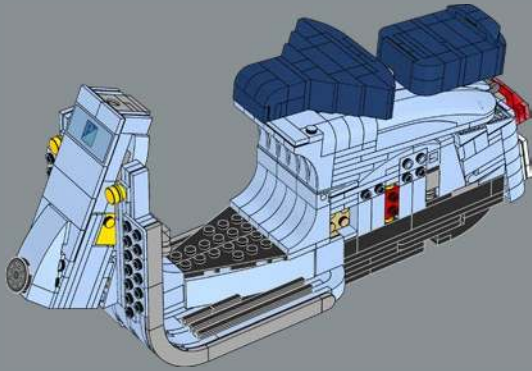
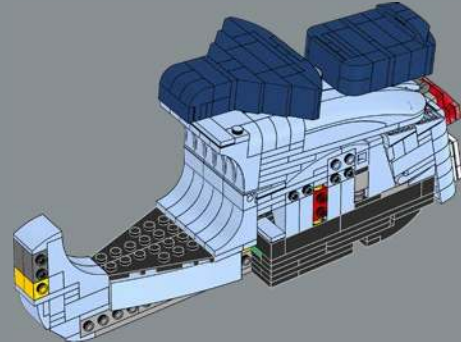
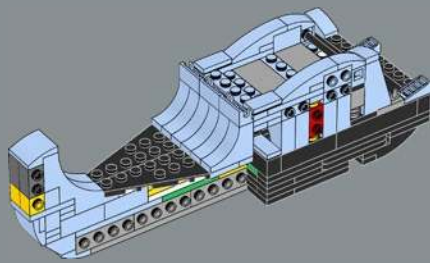

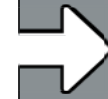
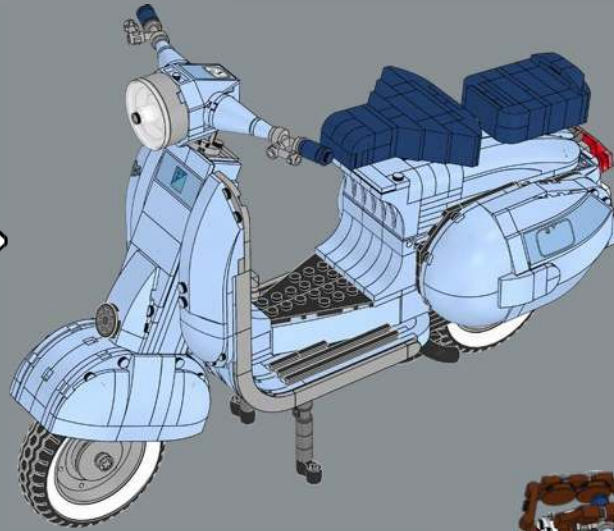
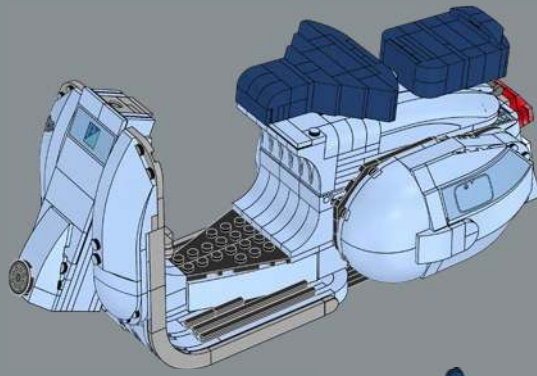

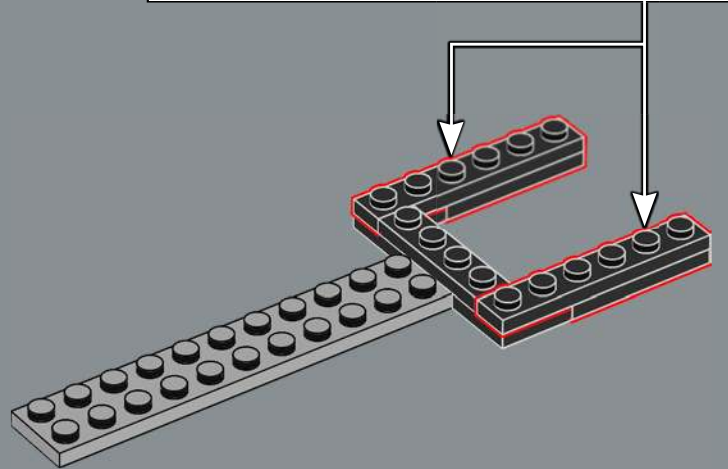
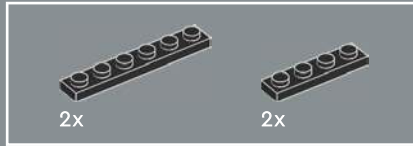
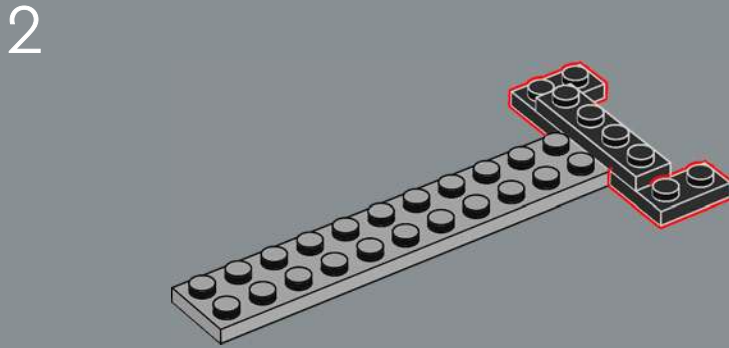
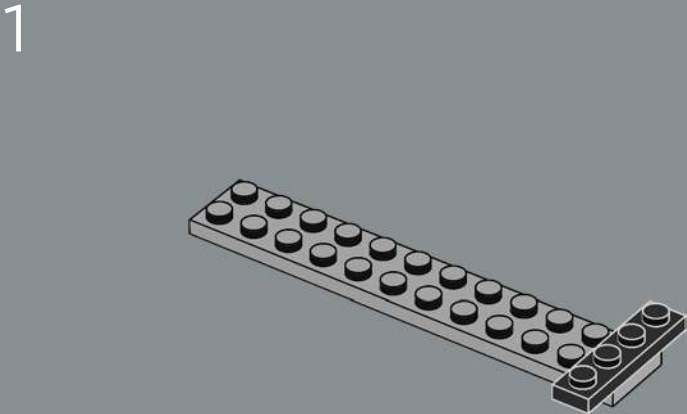
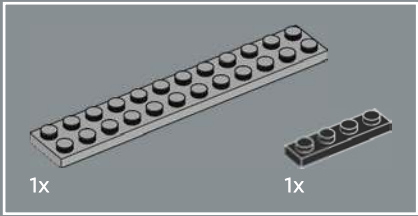
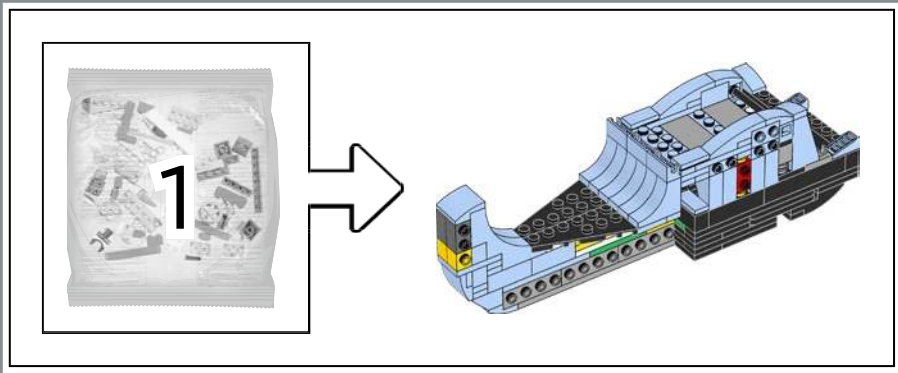



4

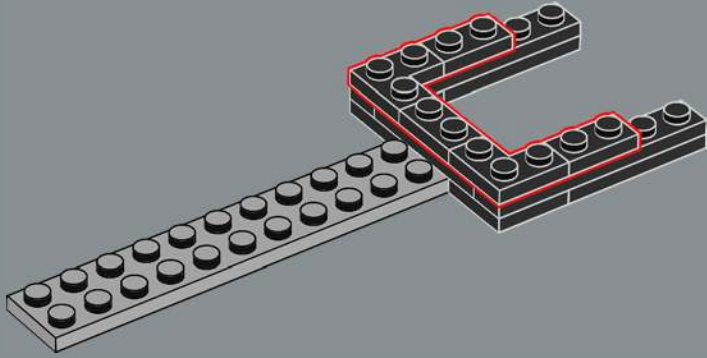

5

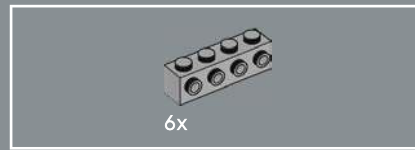
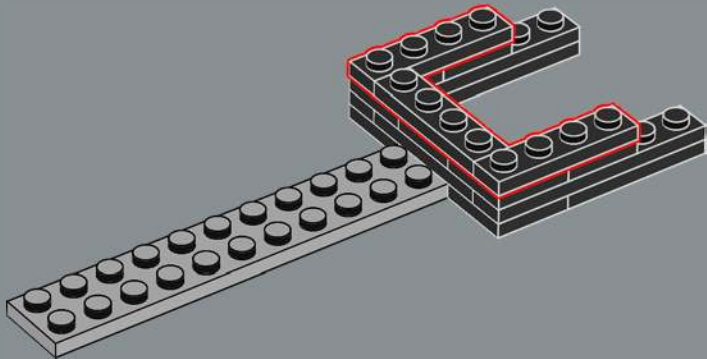

6

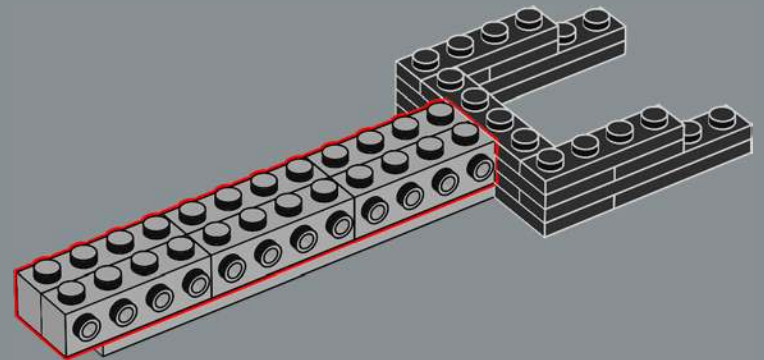

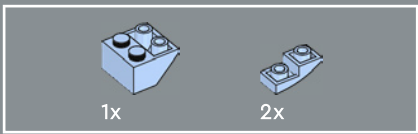

7

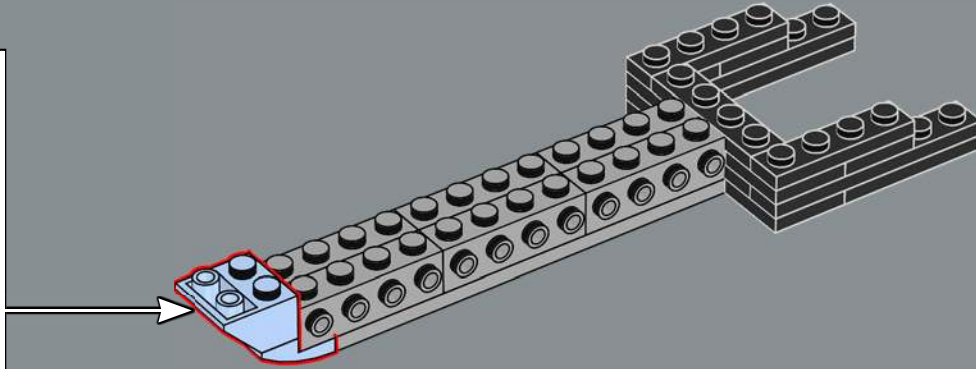
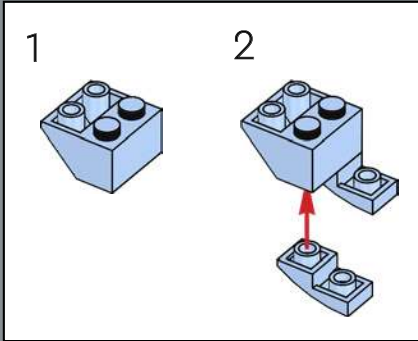

The pastel blue shade that matches the original Vespa is a very rarely used LEGO® colour.

La tonalità blu pastello che riproduce il colore della Vespa originale è un colore LEGO® usato molto raramente.

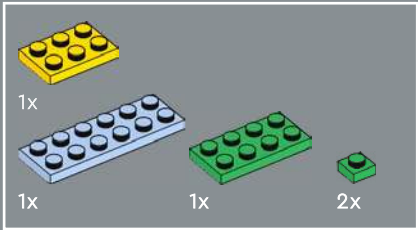

8

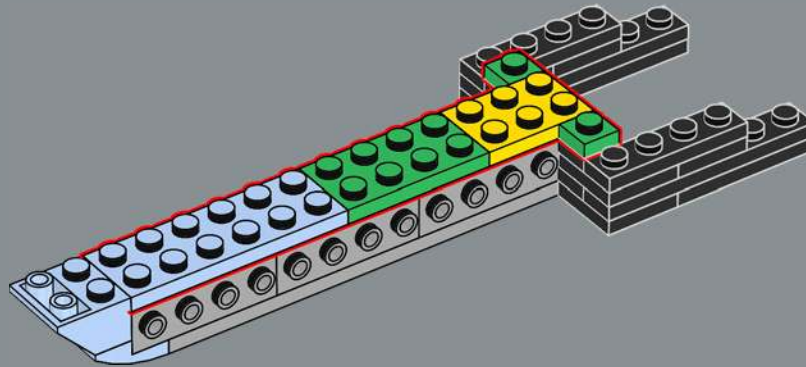

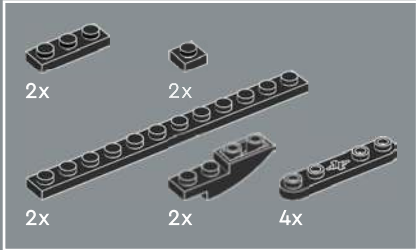
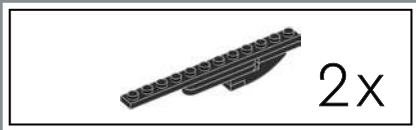

9

1

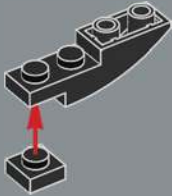

2

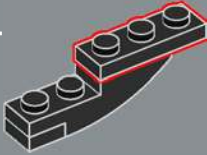

3

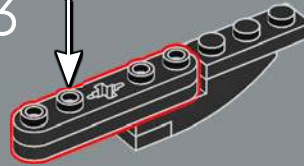
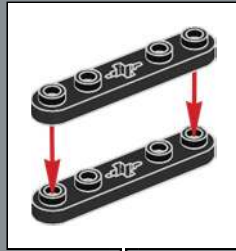

4

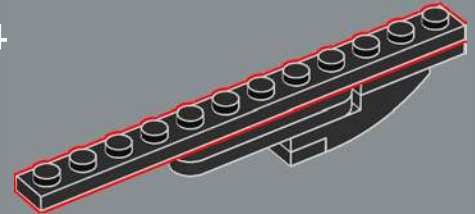

2x

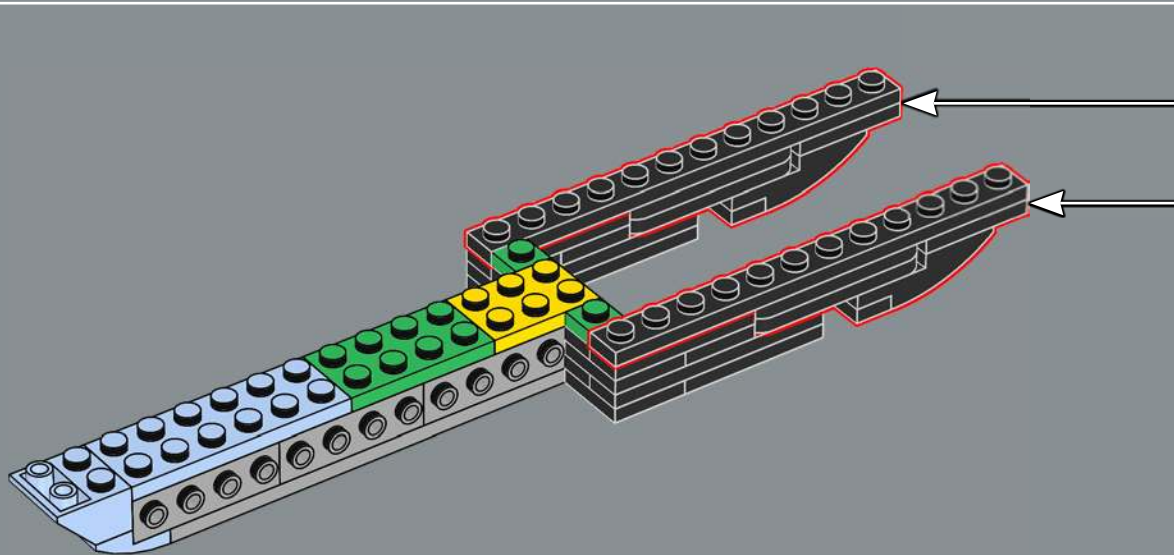

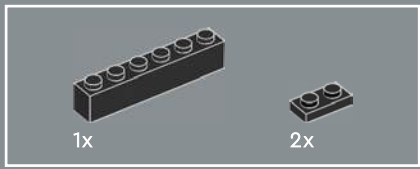

10

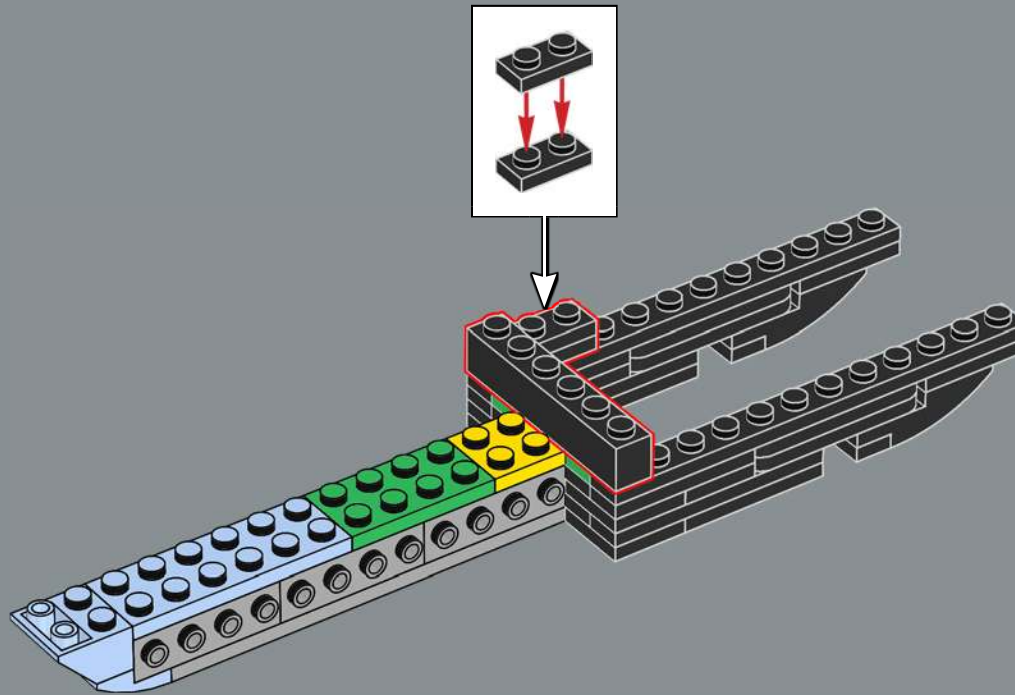

11

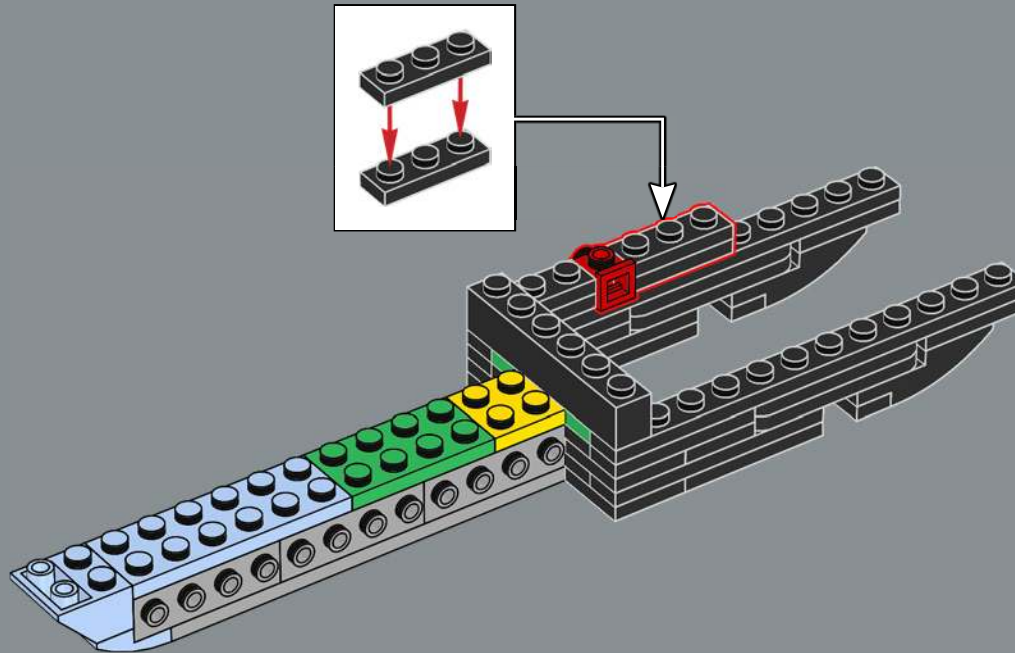

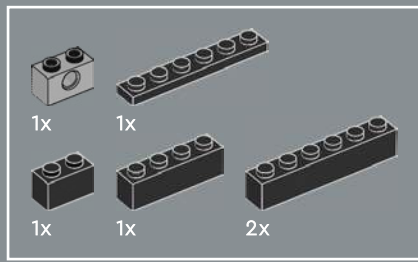

12

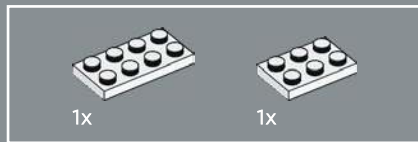
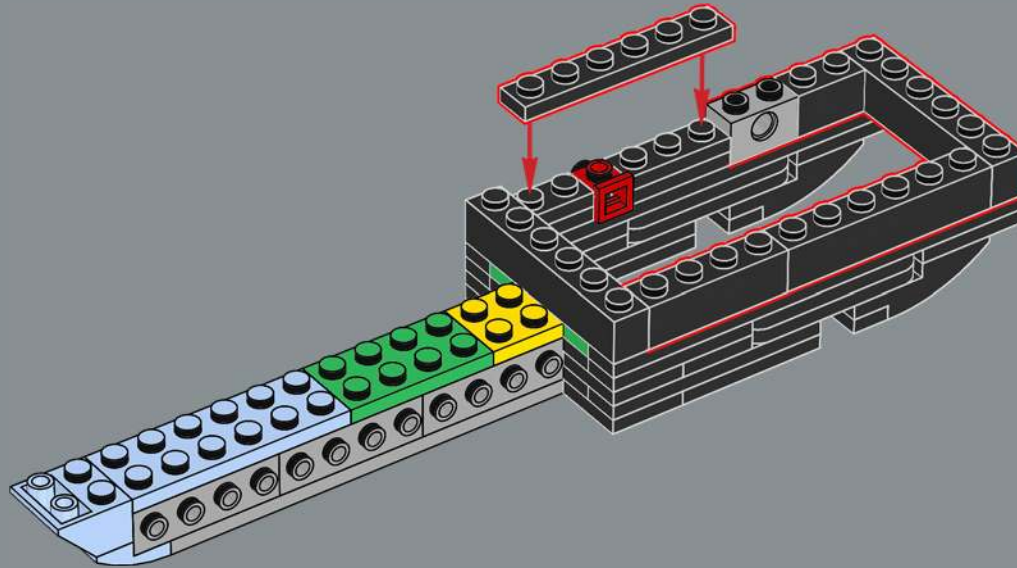

13

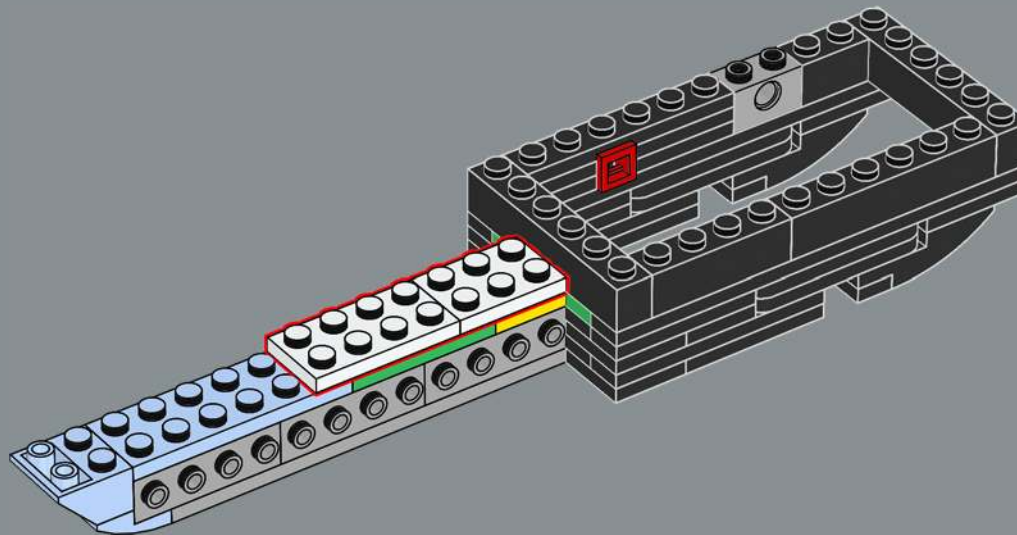

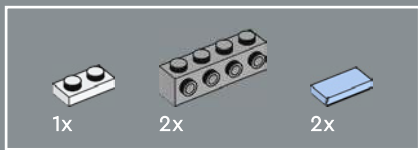

14

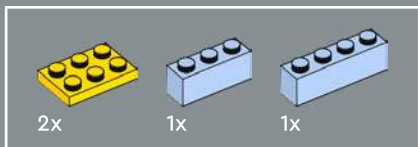
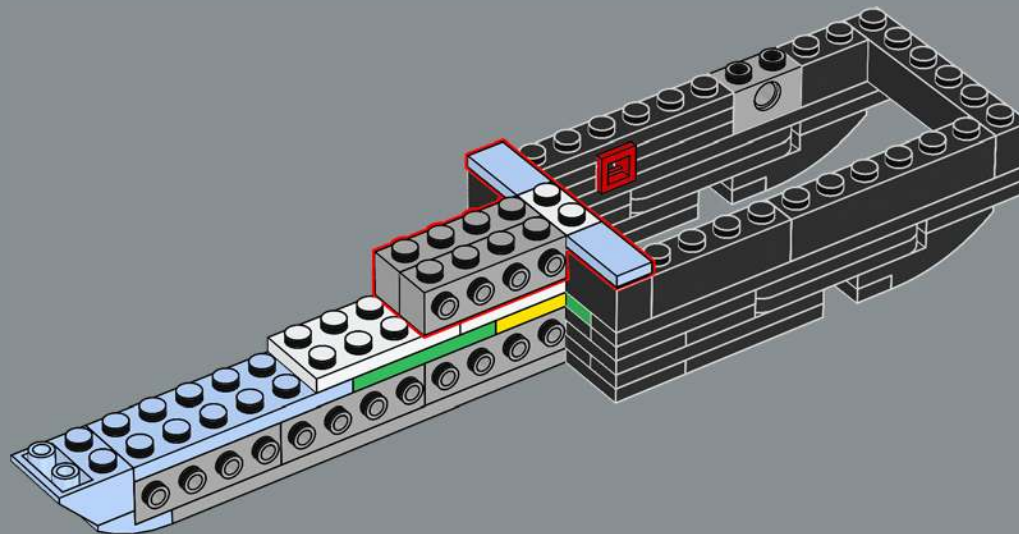

15

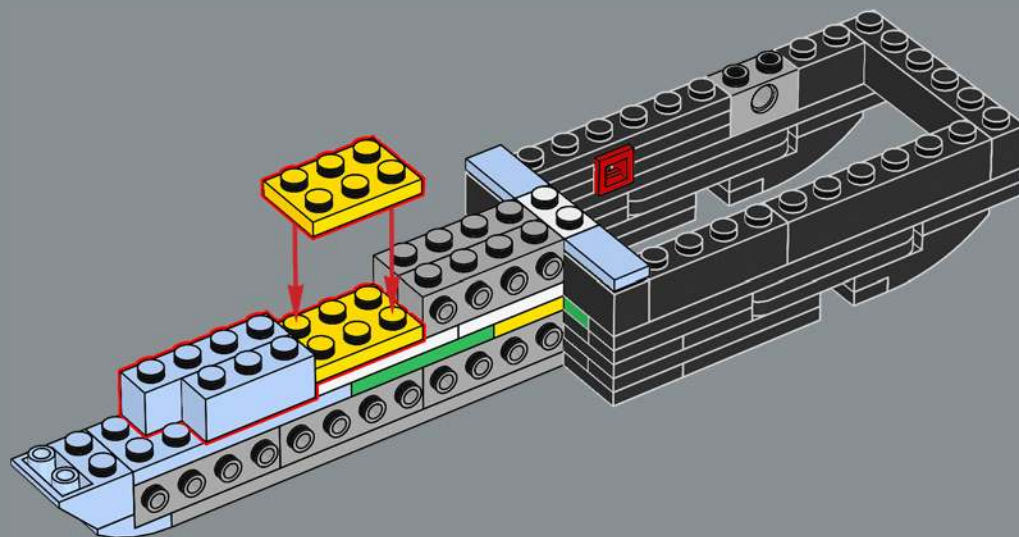

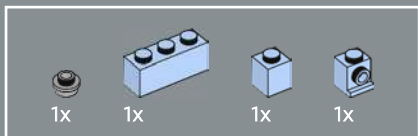

16

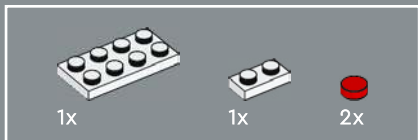
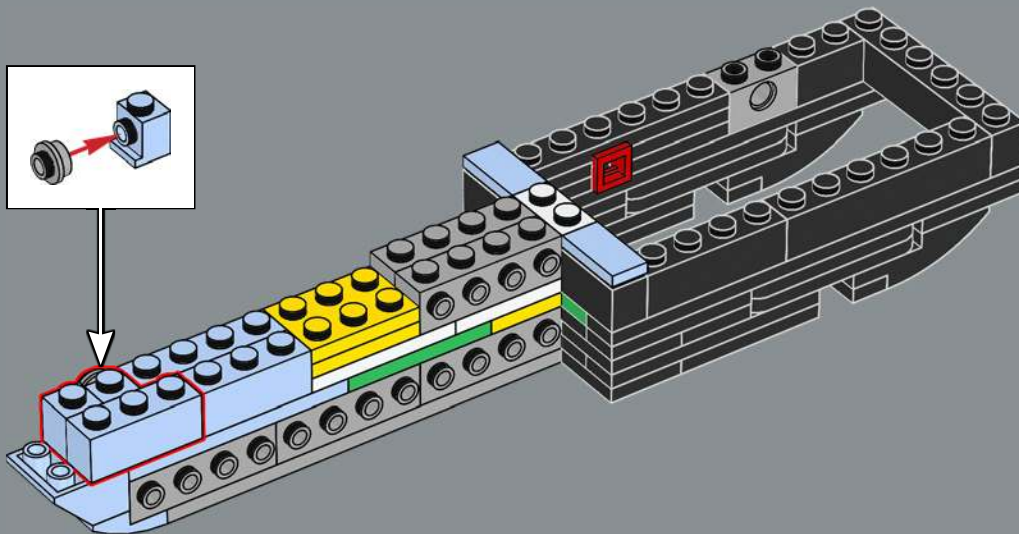
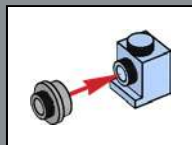

17

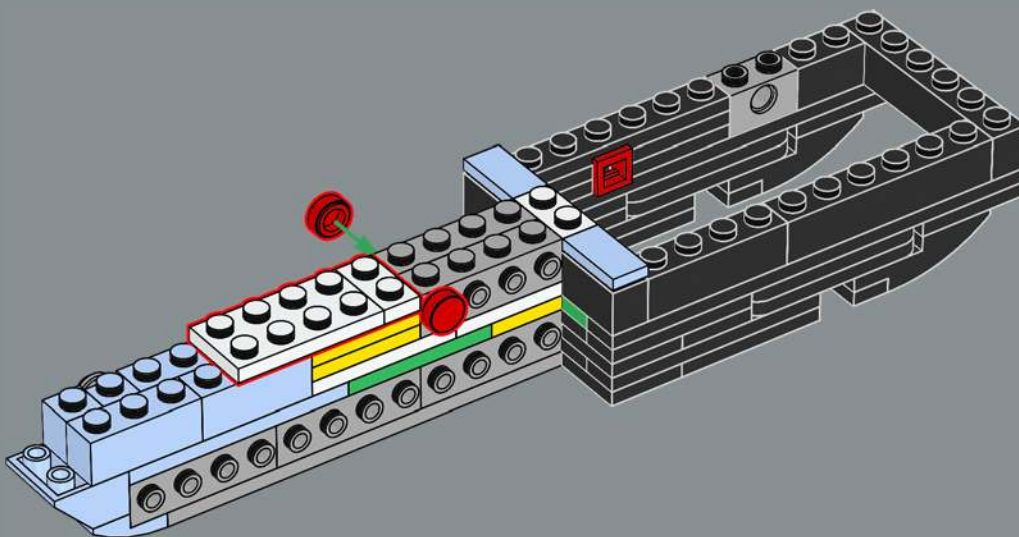

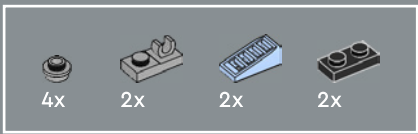

18

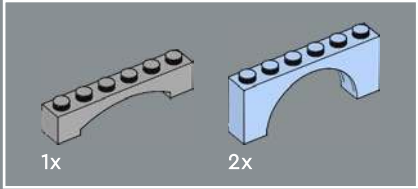
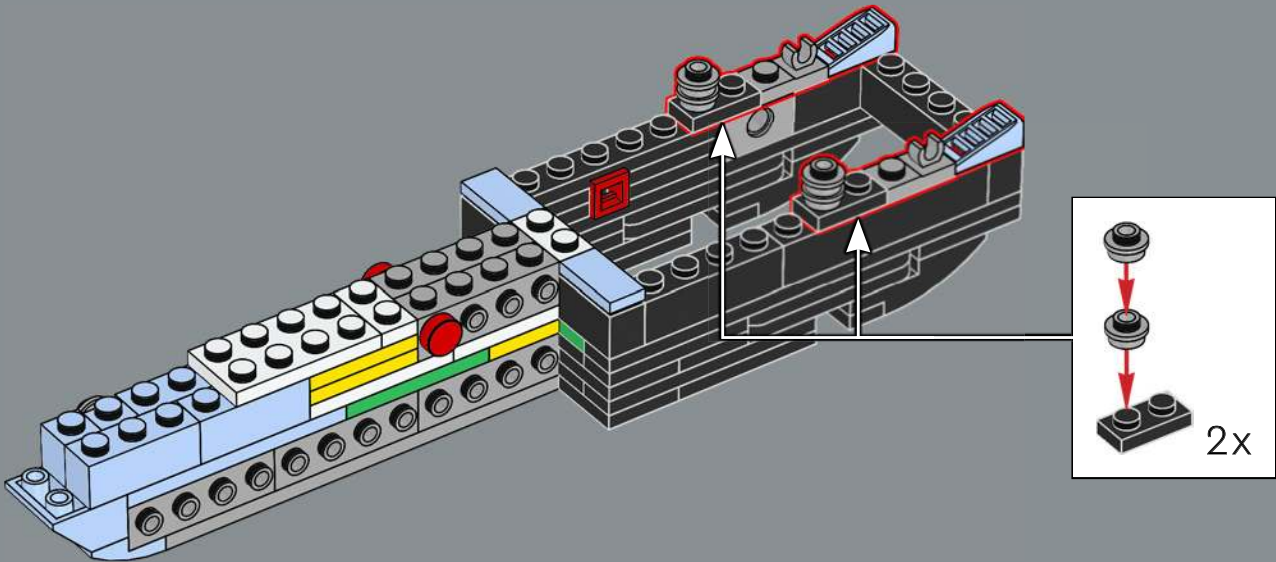

19

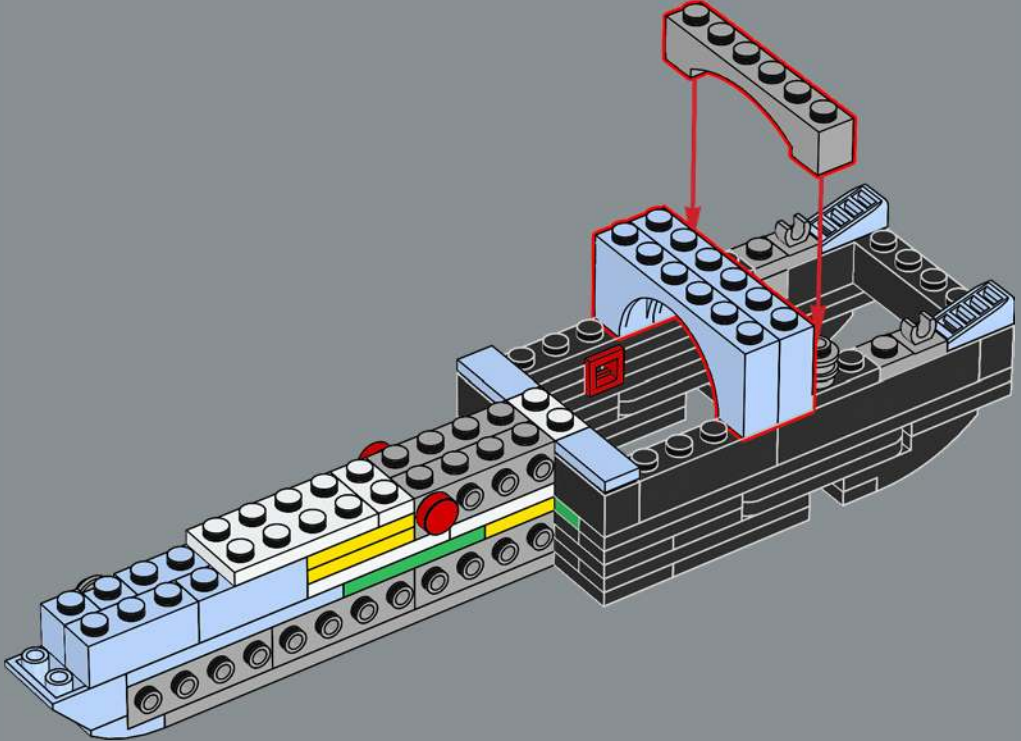



20

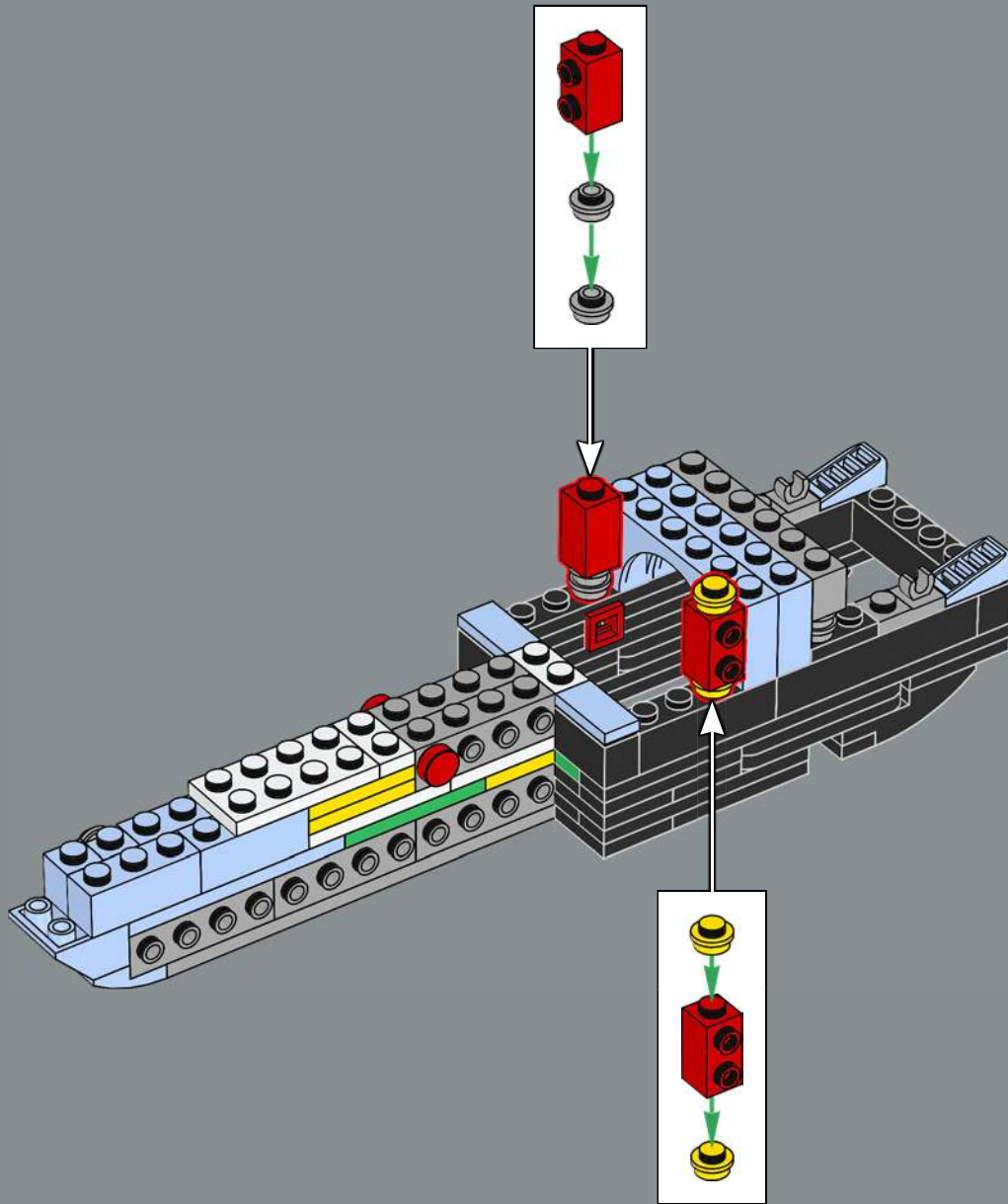

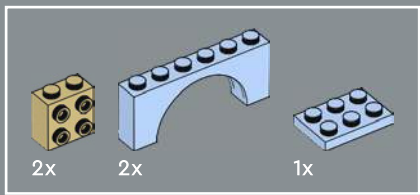

21

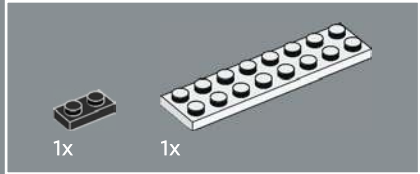
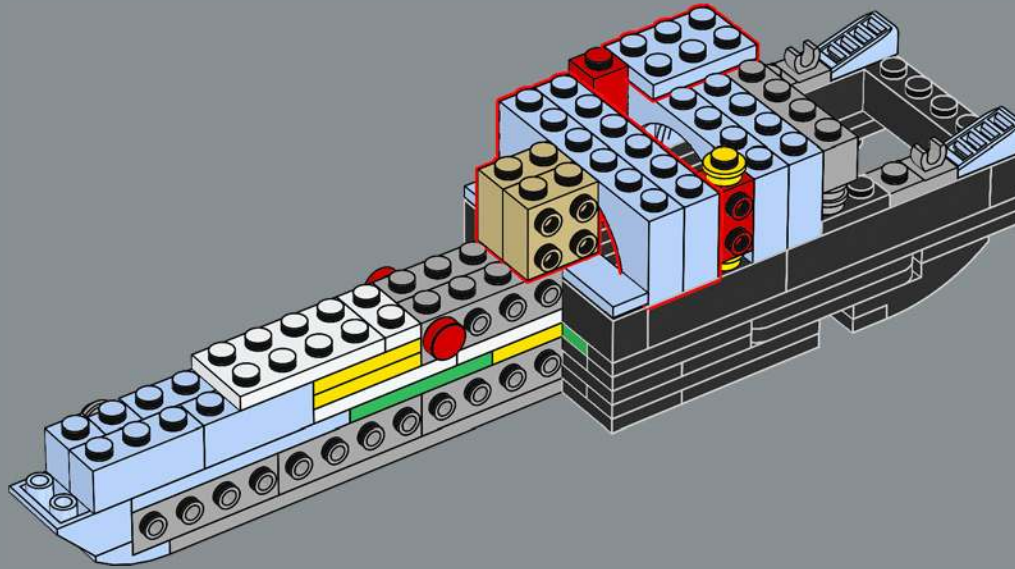

22

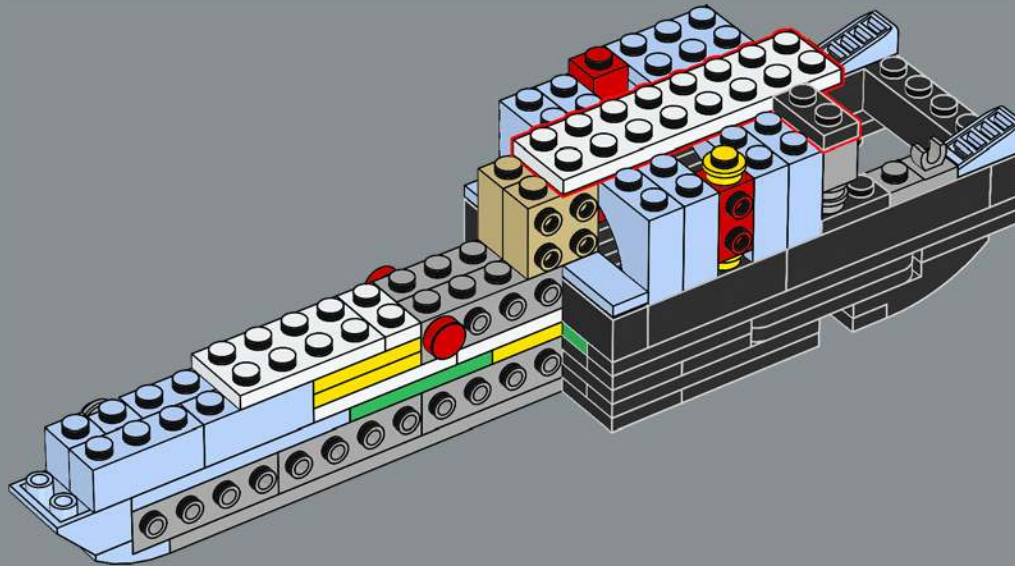

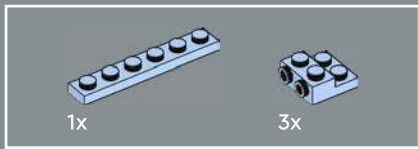

23

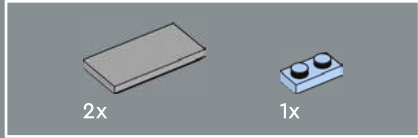
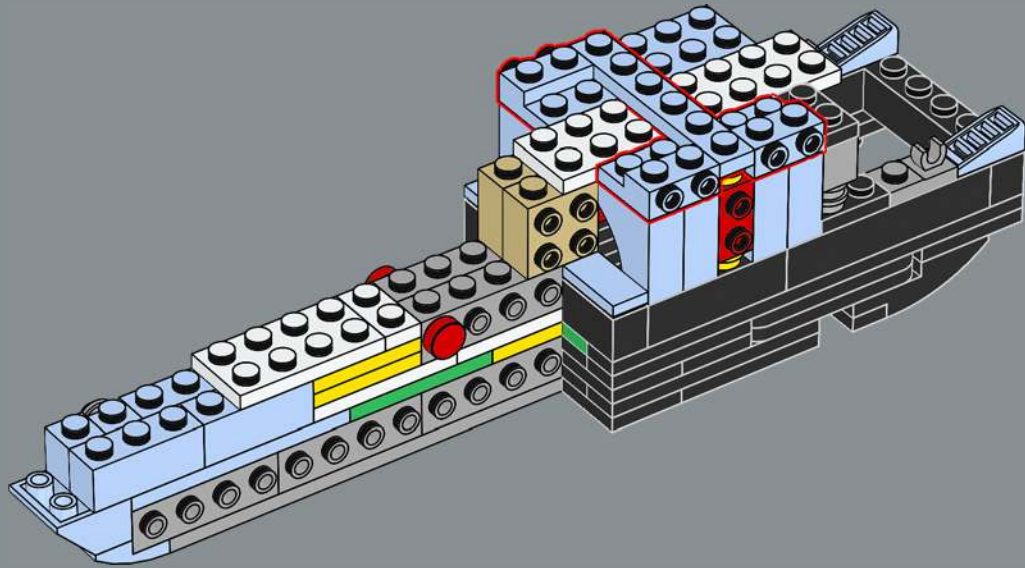

24

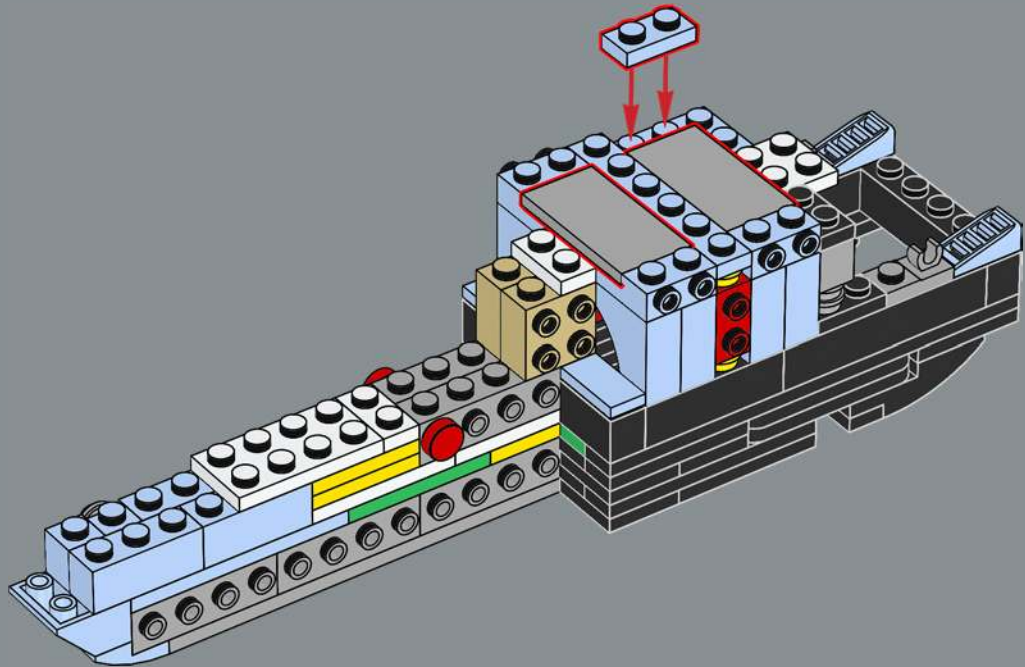

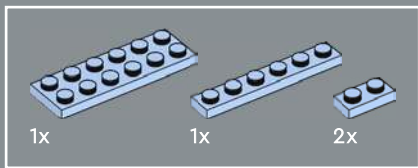

25

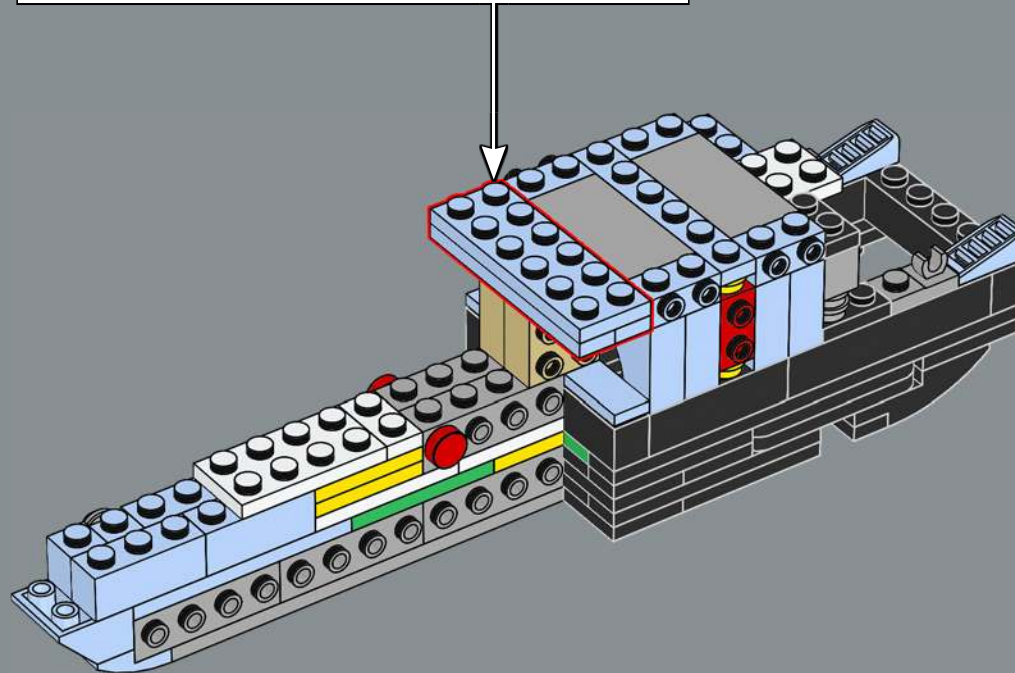
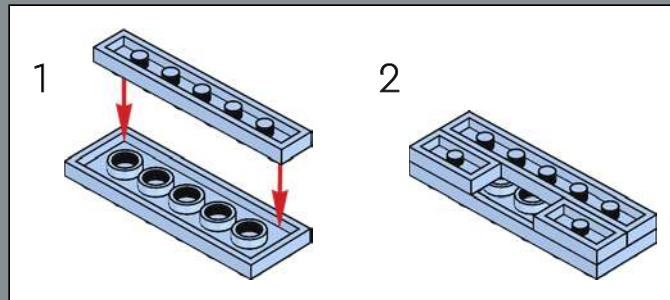

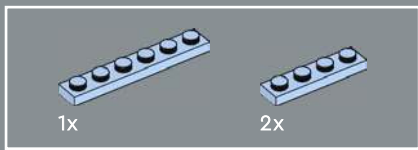

26

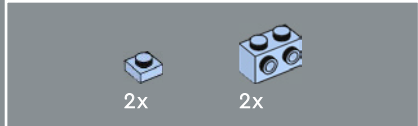
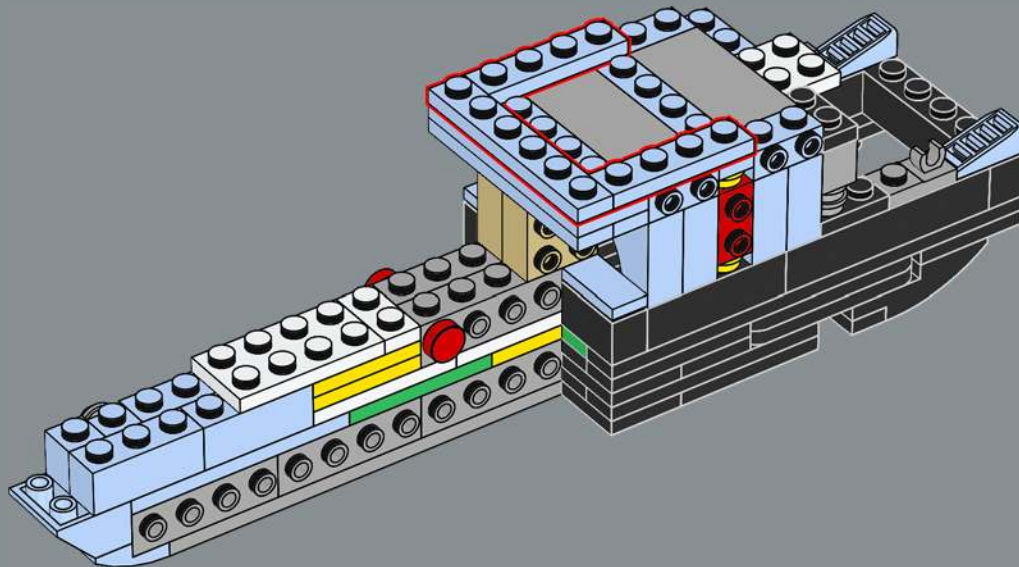

27

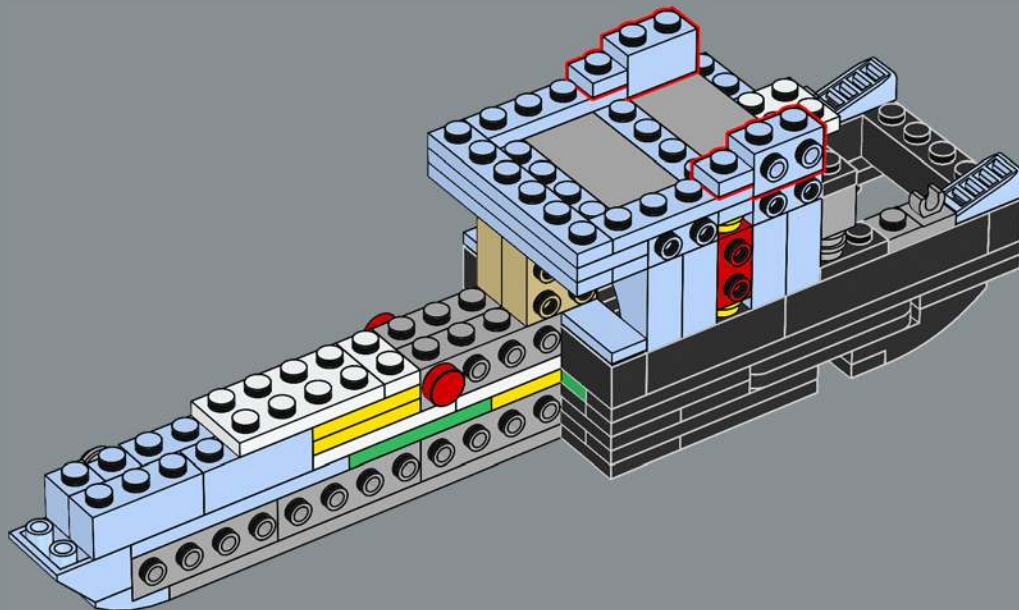



28

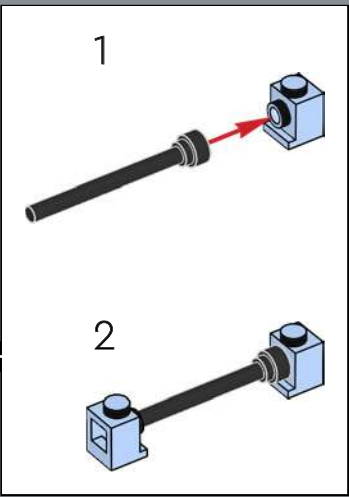
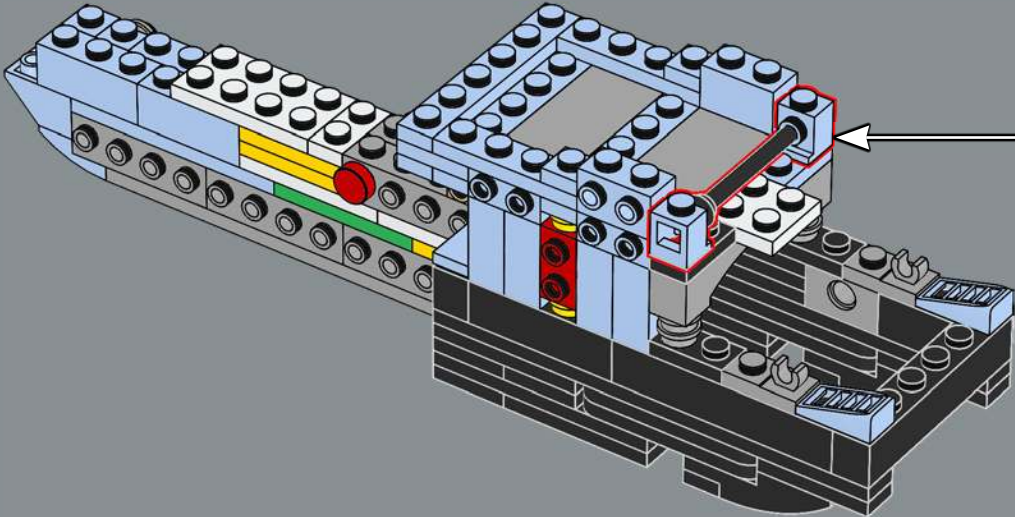

29

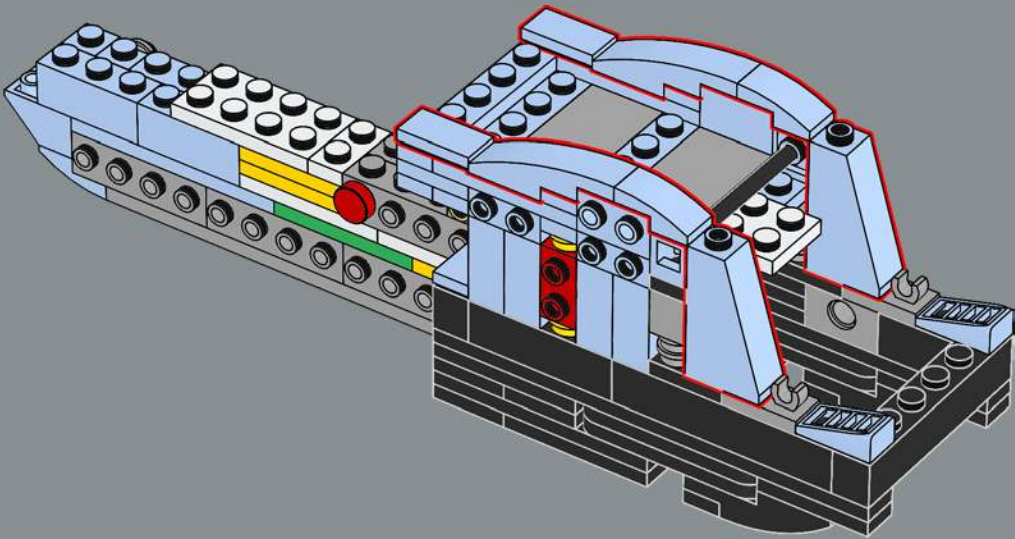

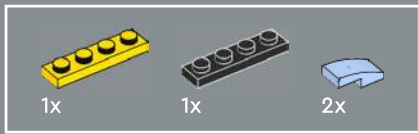

30

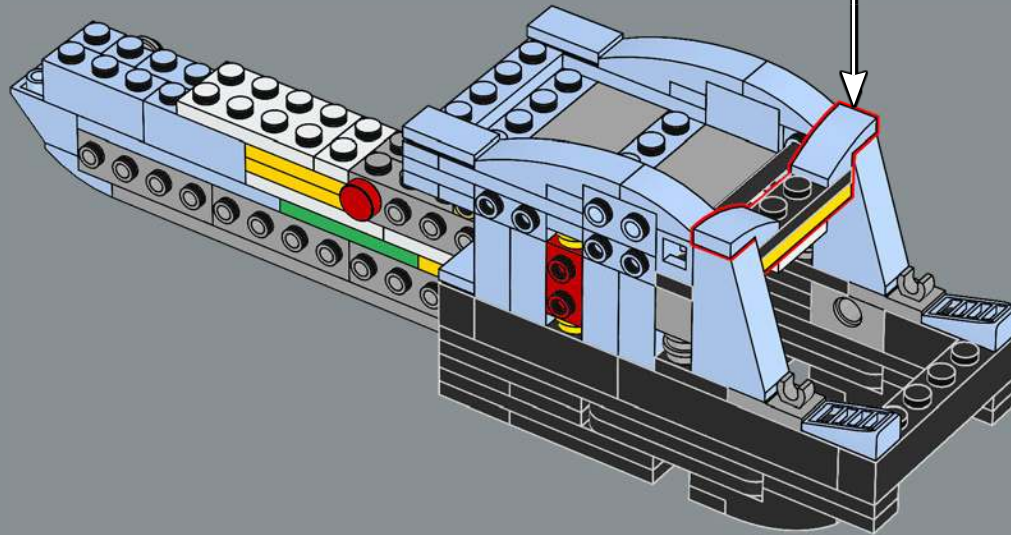
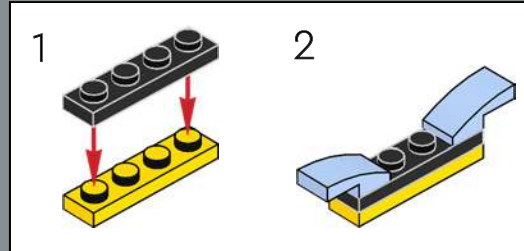

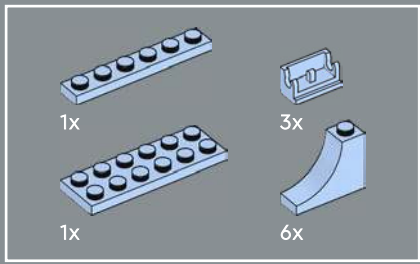

31

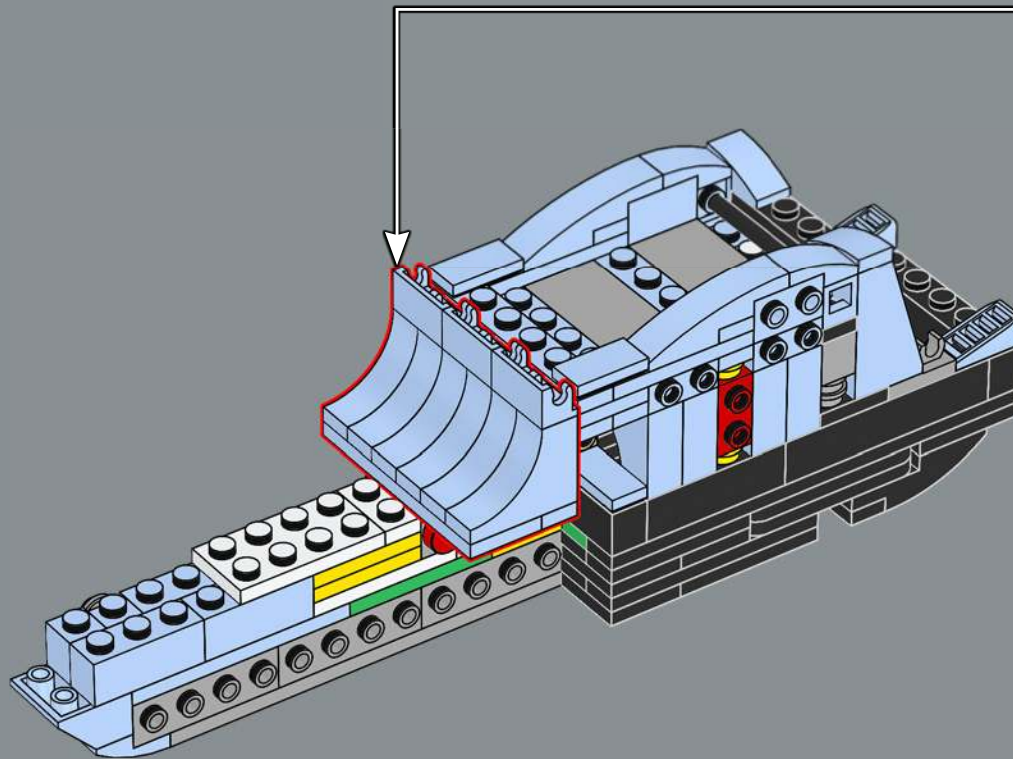
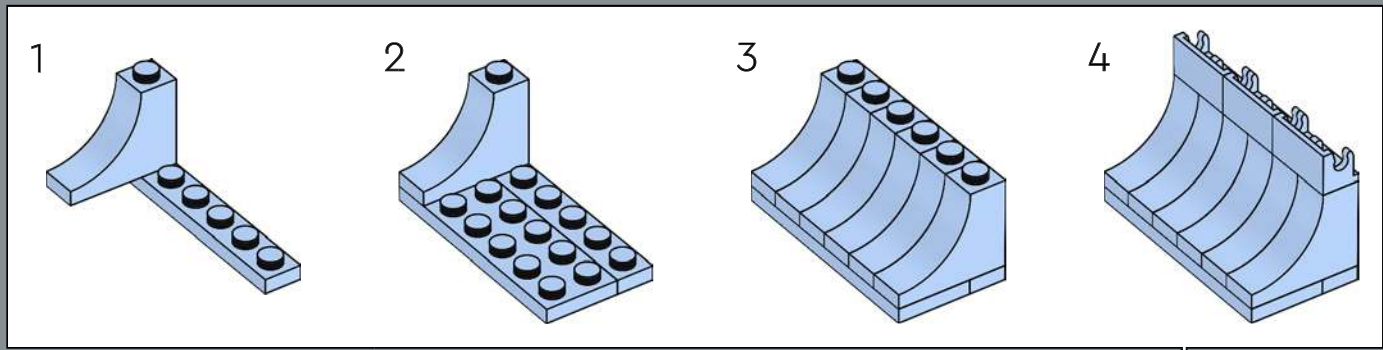

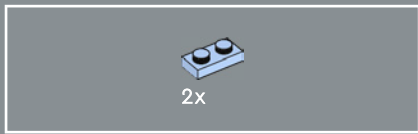

32

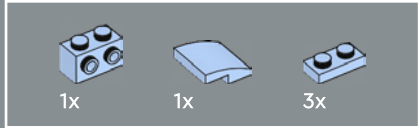
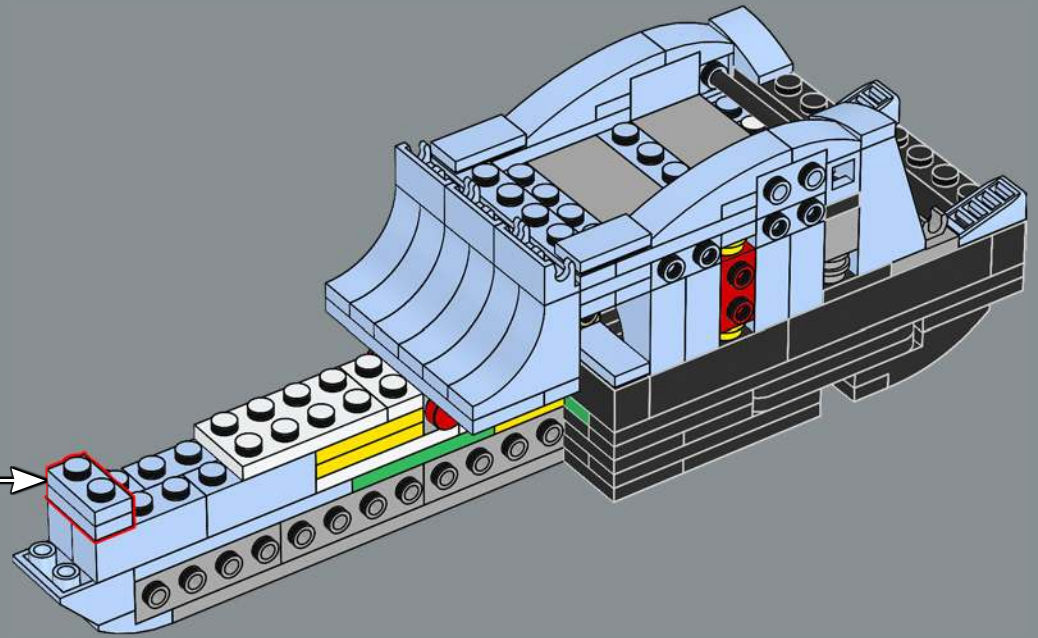
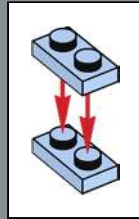

33

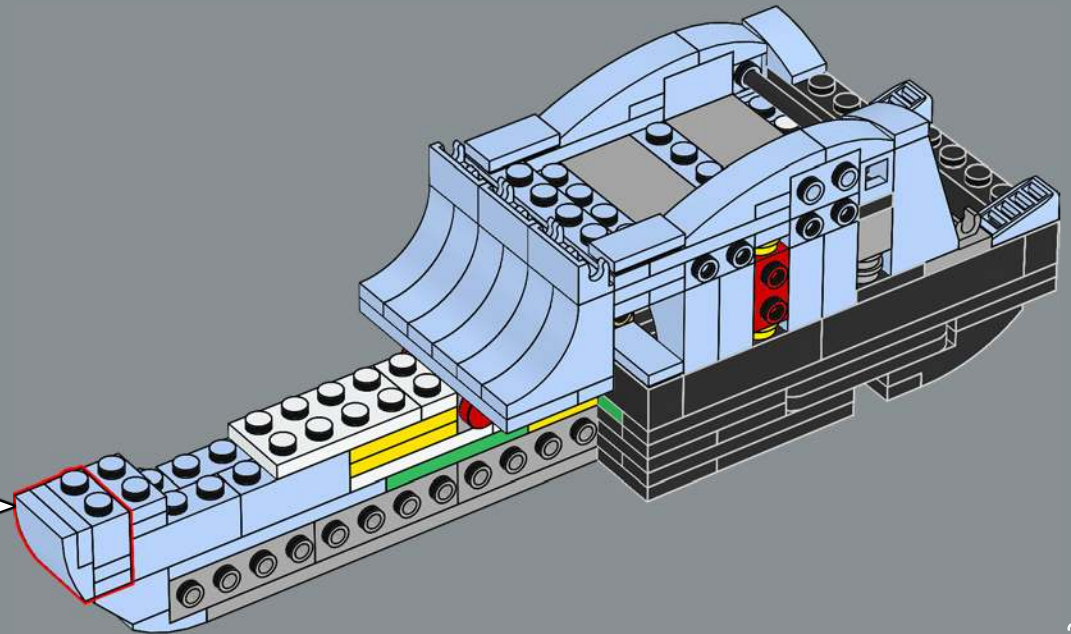
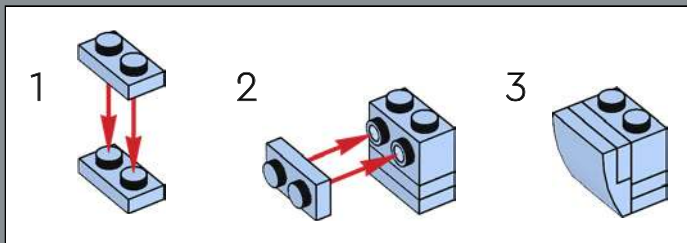

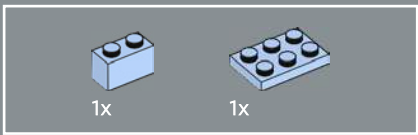

34

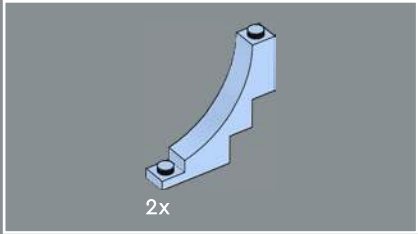
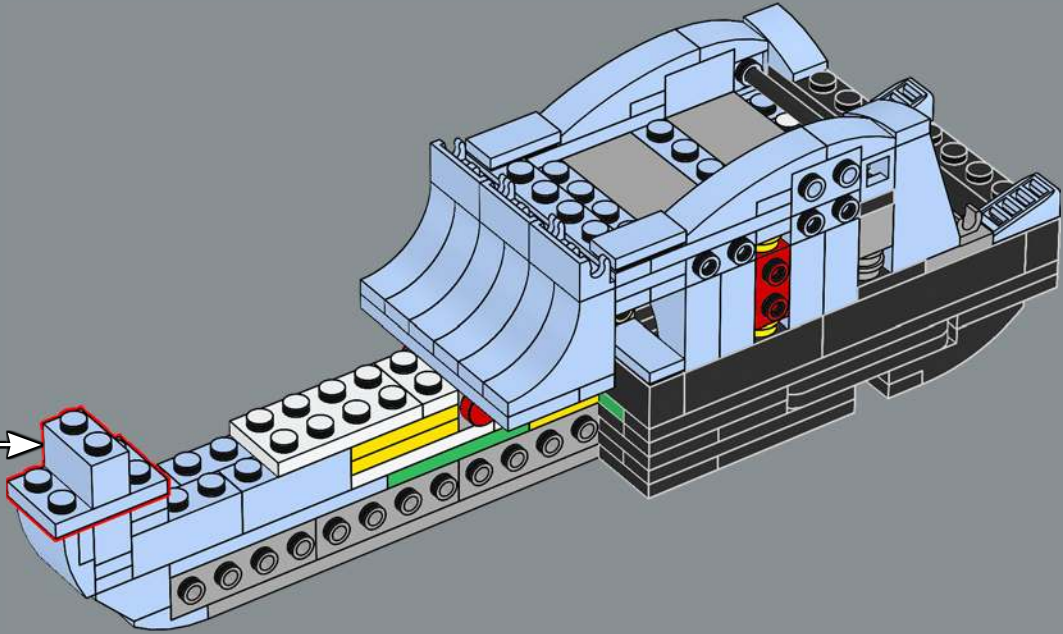
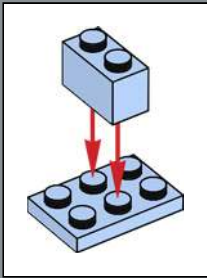

35

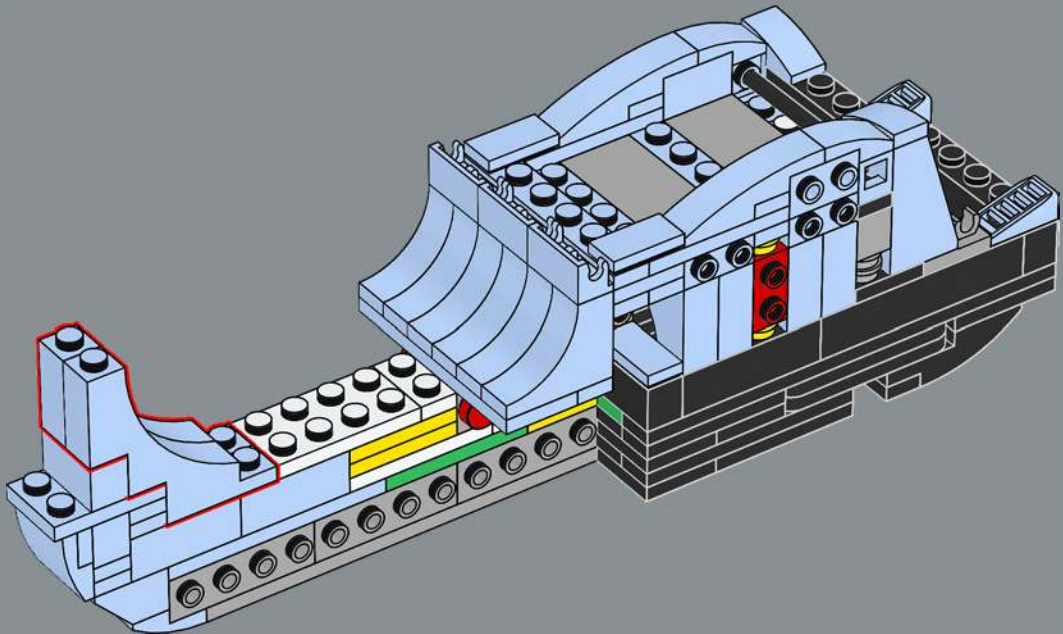

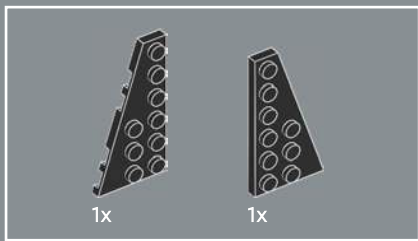

36

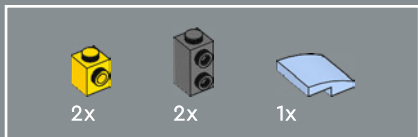
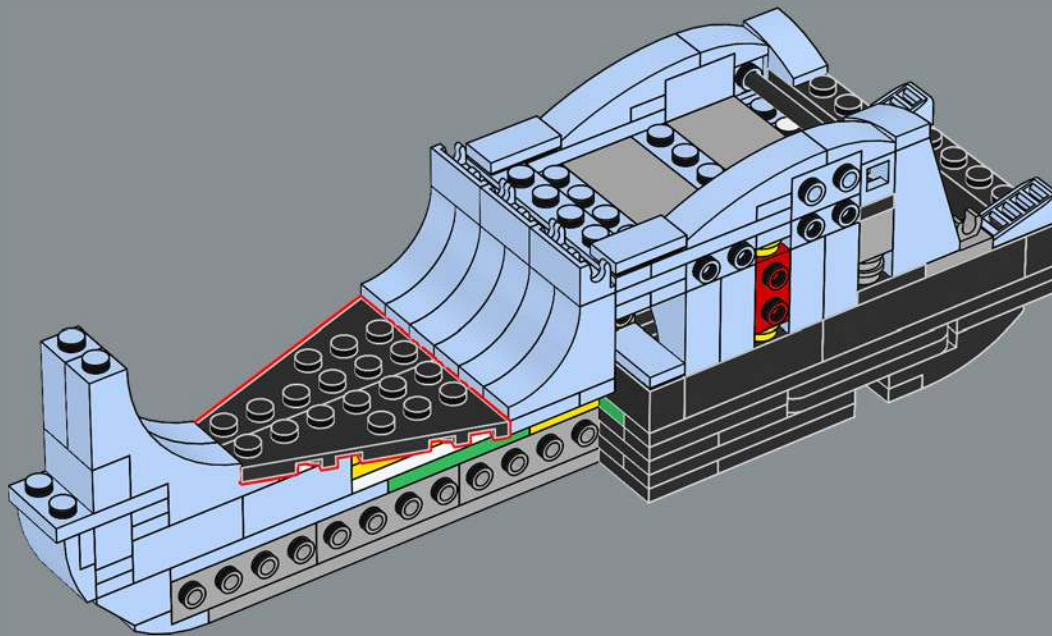

37

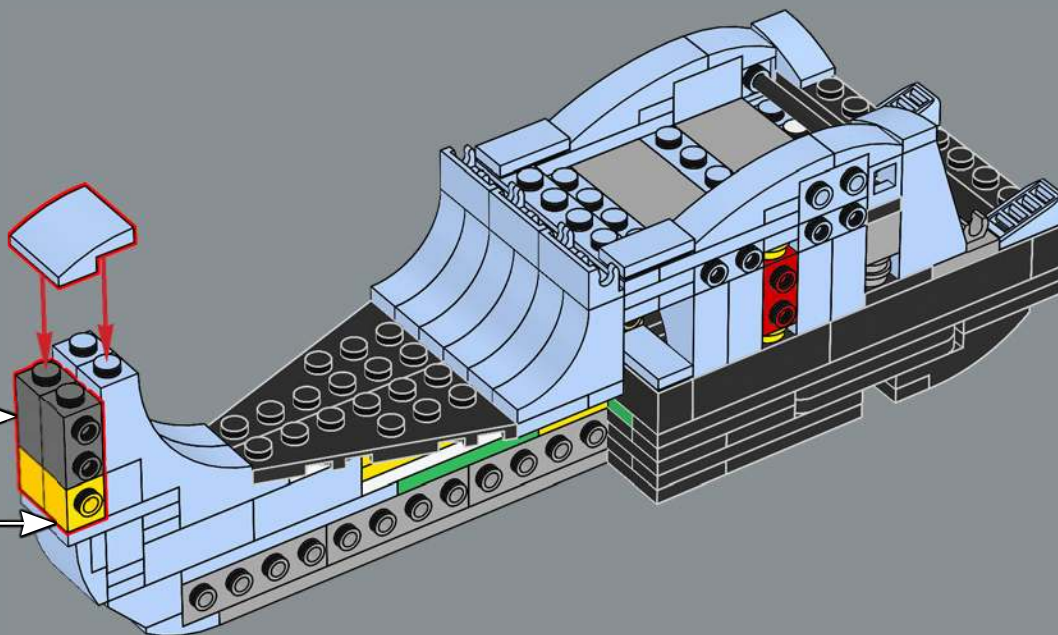
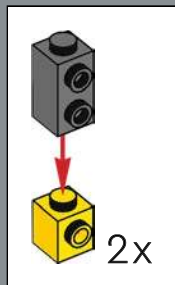

As of 2021, a total of 19 million Vespa scooters
have been produced.

Nel 2021 Vespa raggiunge il traguardo di 19
milioni di esemplari prodotti.

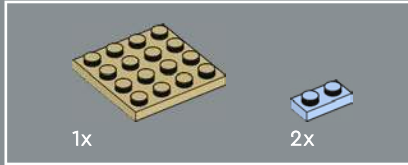
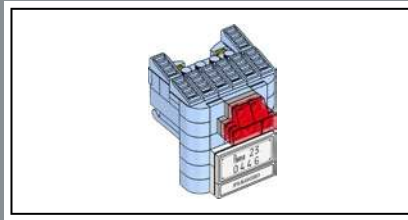
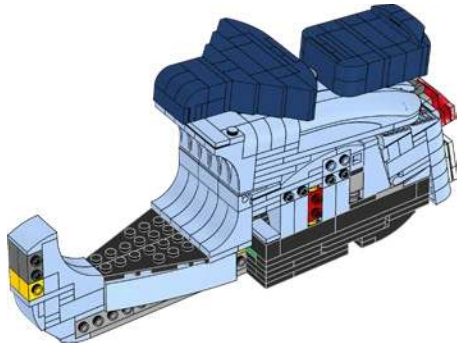
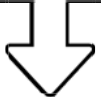

38

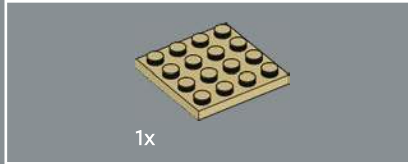
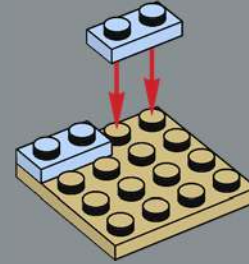

39

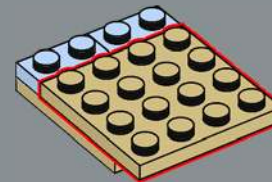



40

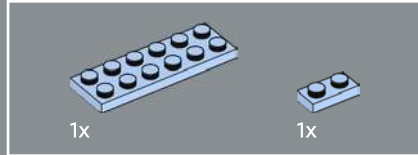
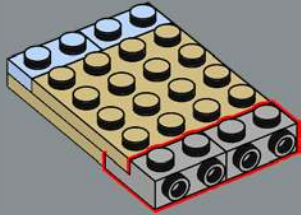

41

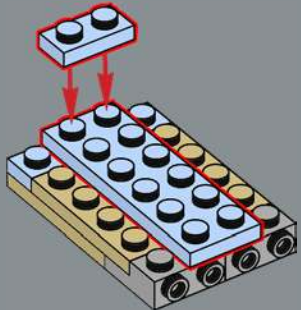

42

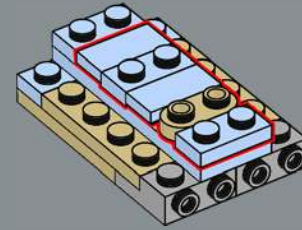

43

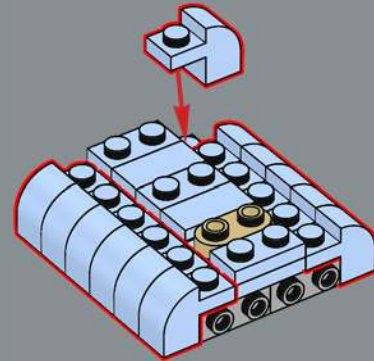

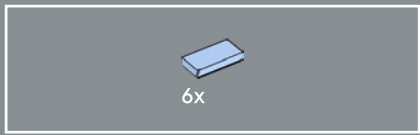

44

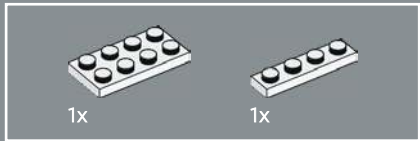
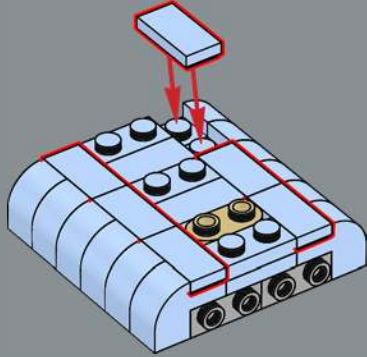

45

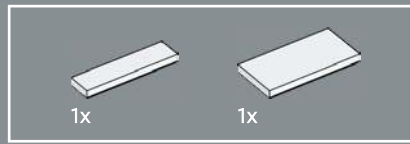
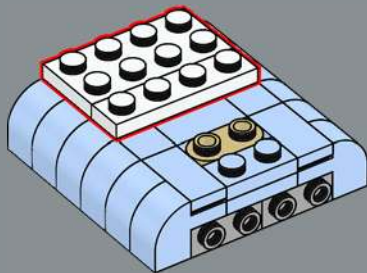

46

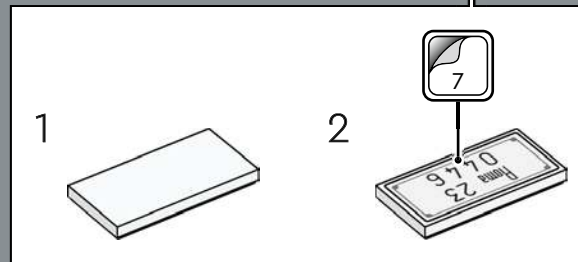
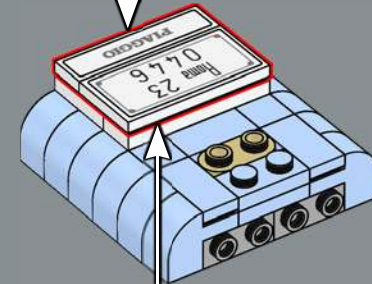
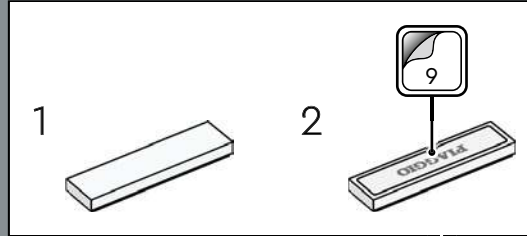

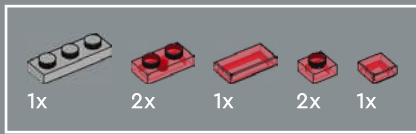

47

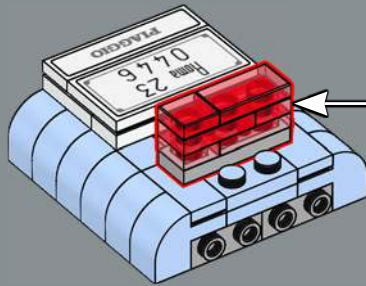
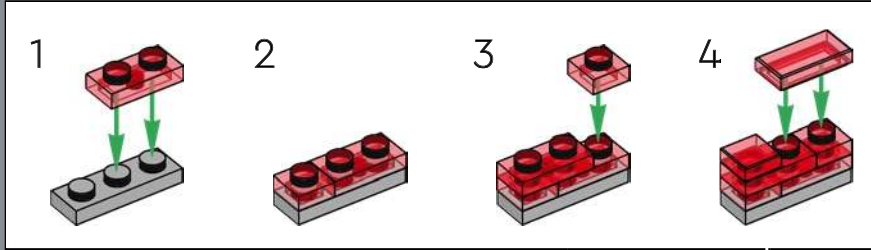

48

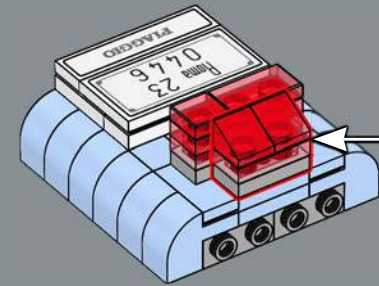
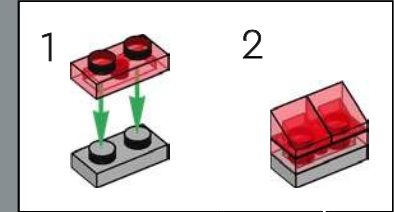

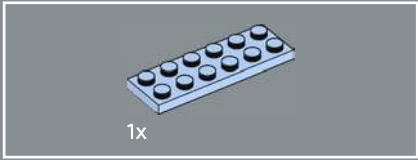
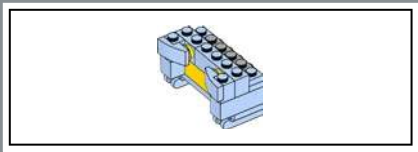

1x

49

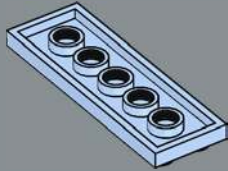

2x

50

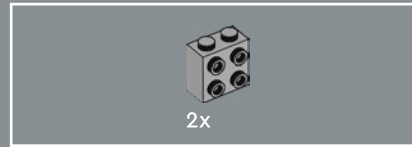
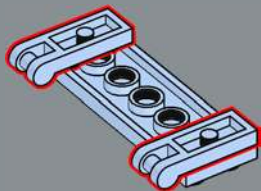

2x

51

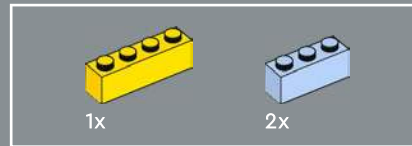
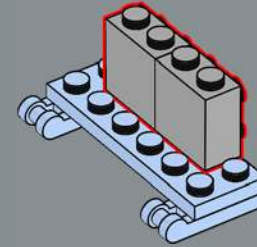

1x

2x

52

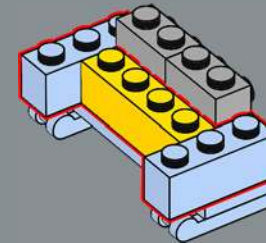



53

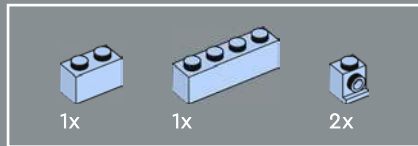
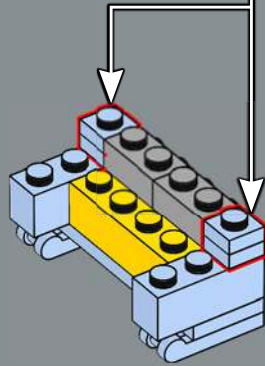
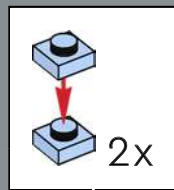

54

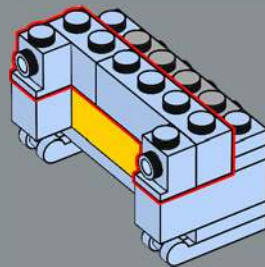

55

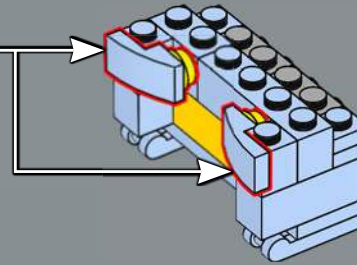
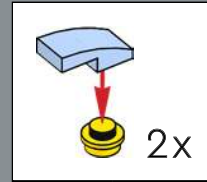

56

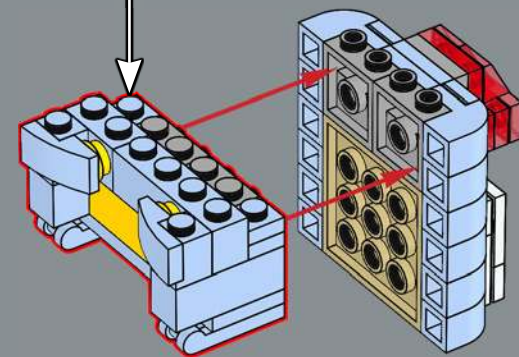



8x

57

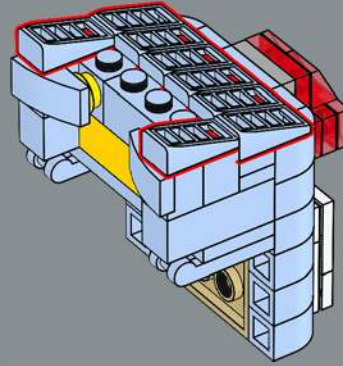

58

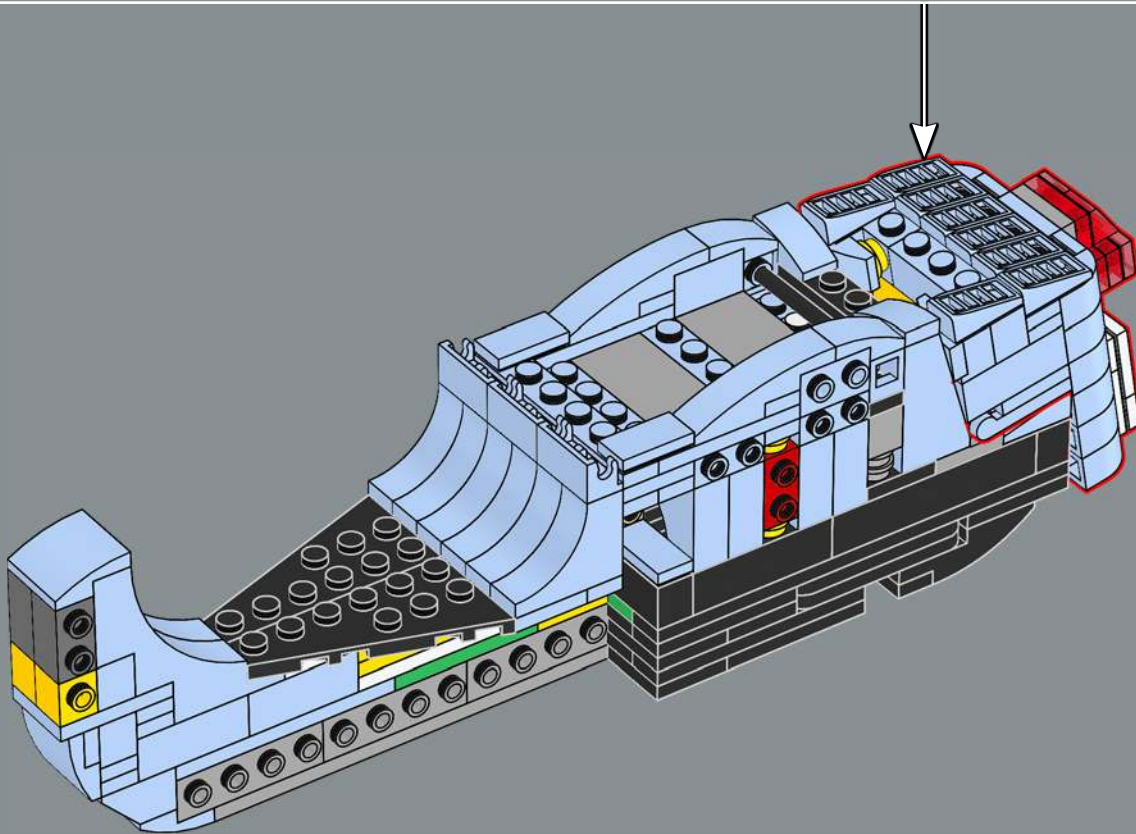

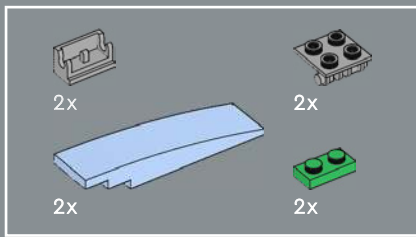

59

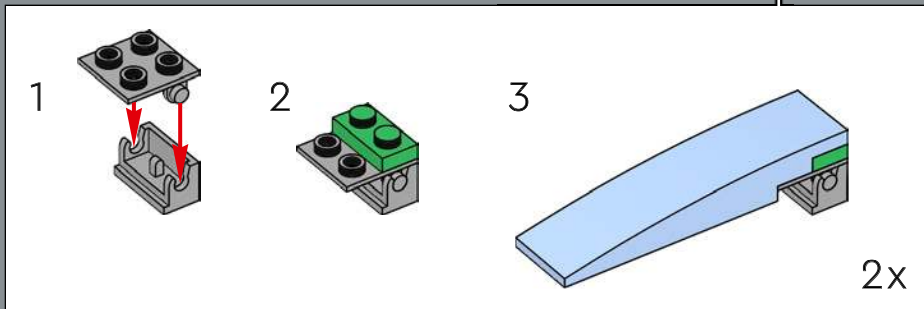
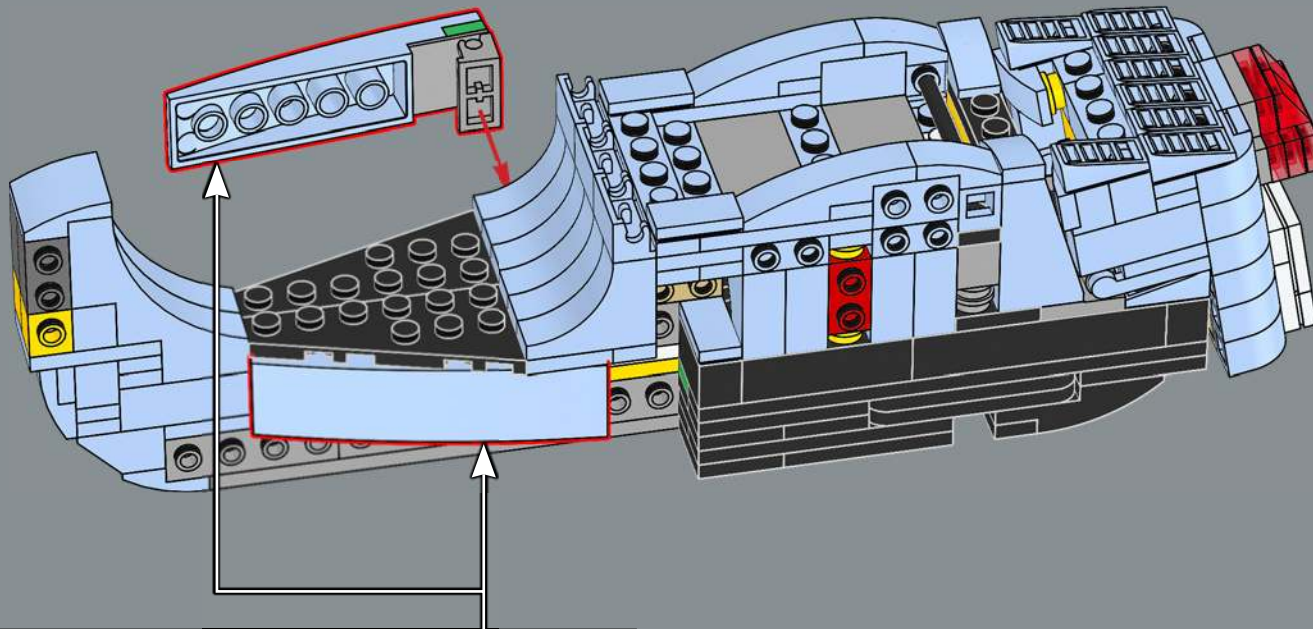

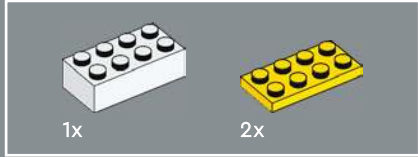
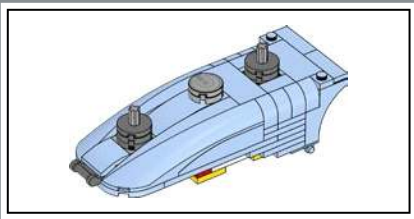

60

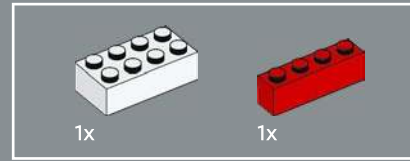
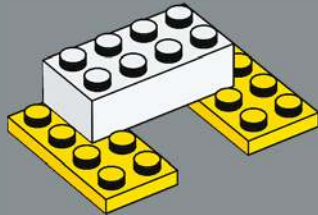

61

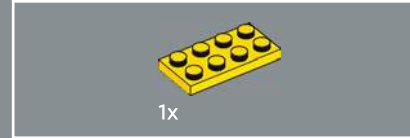
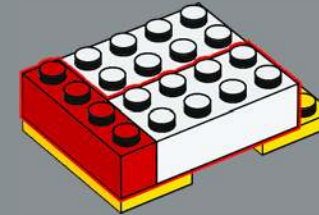

62

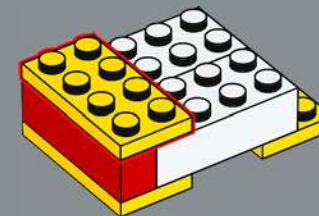

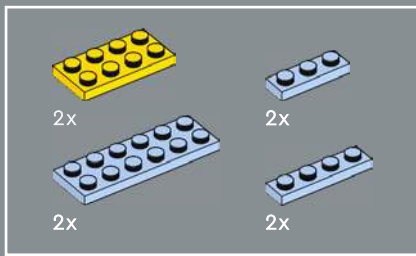

63

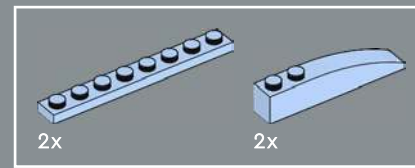
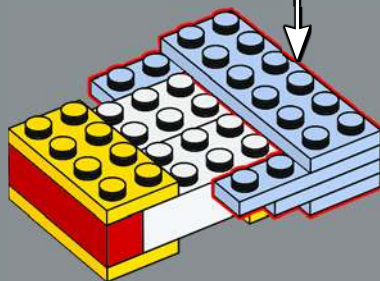
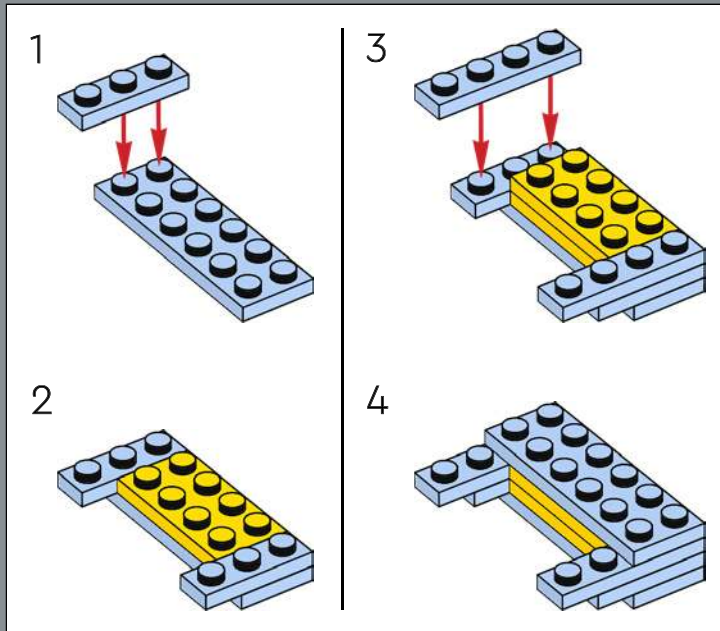

64

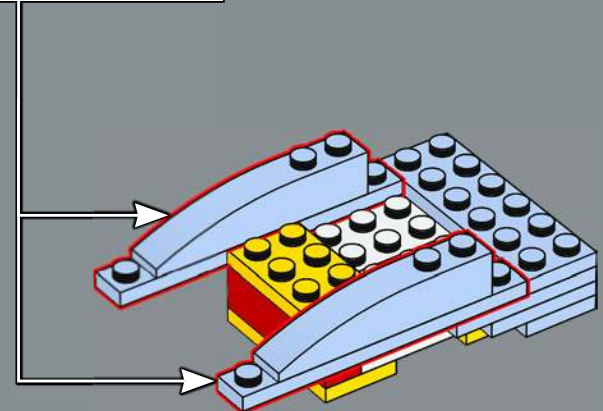
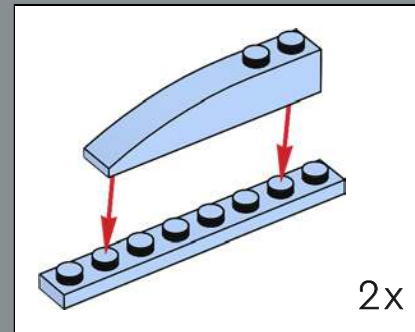

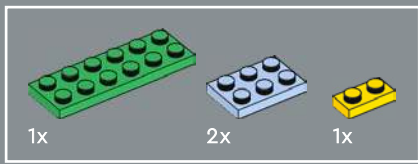

65

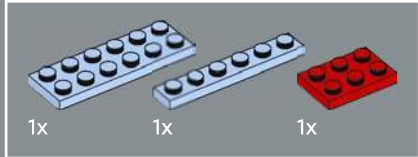
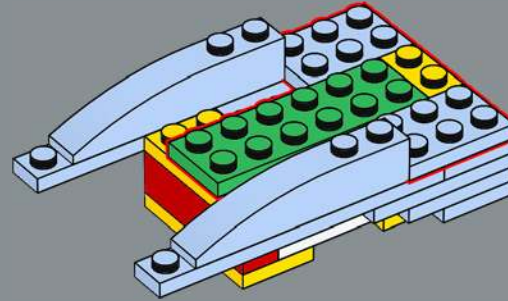

66

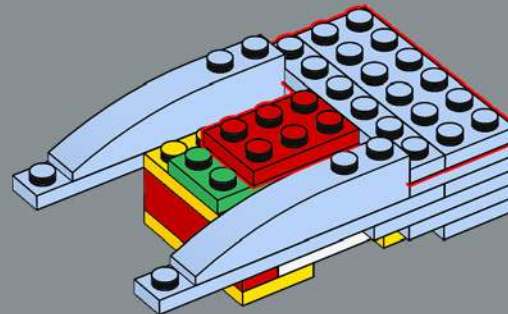

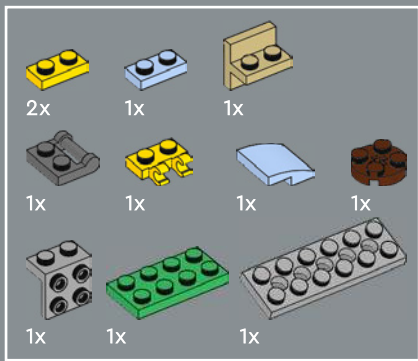

67

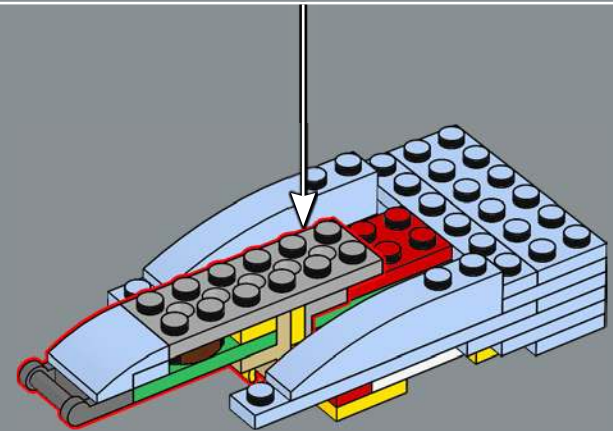
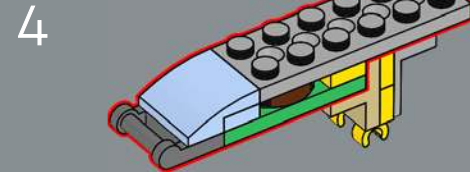
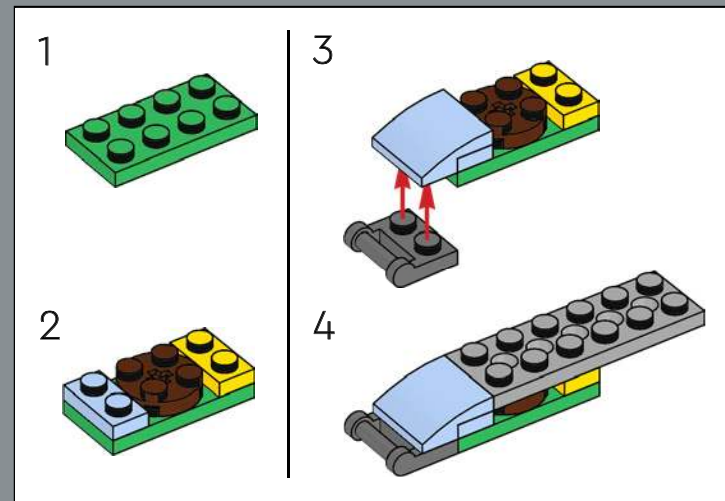
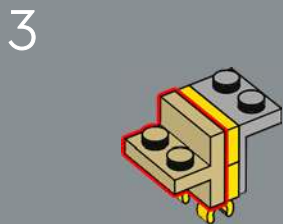
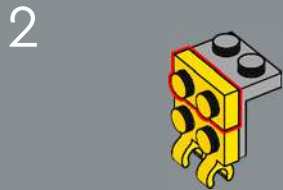
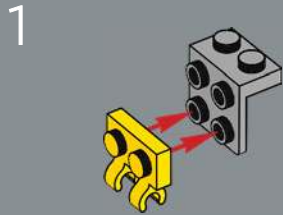

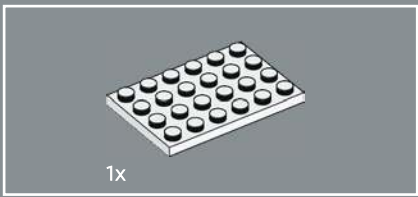

68

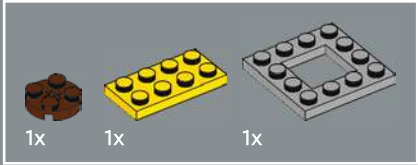
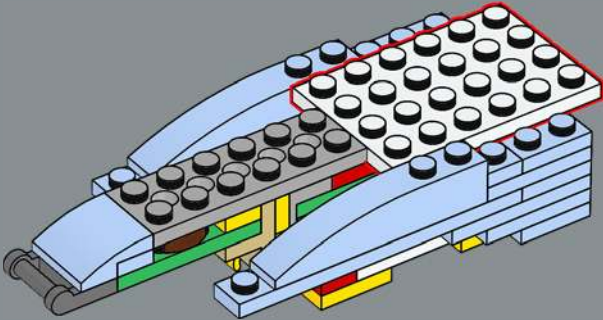

69

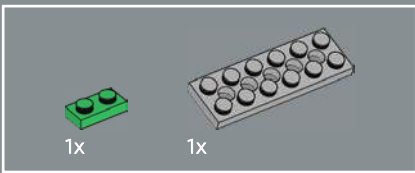
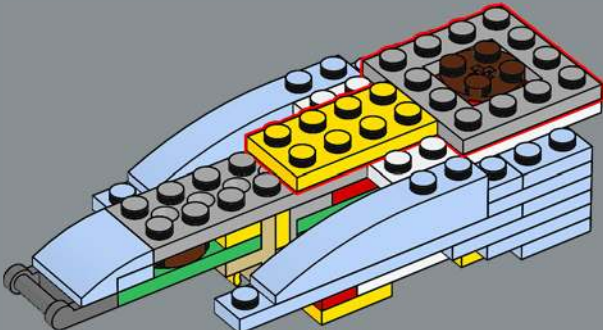

70

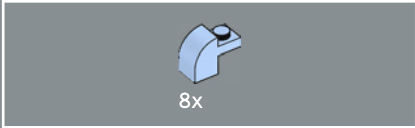
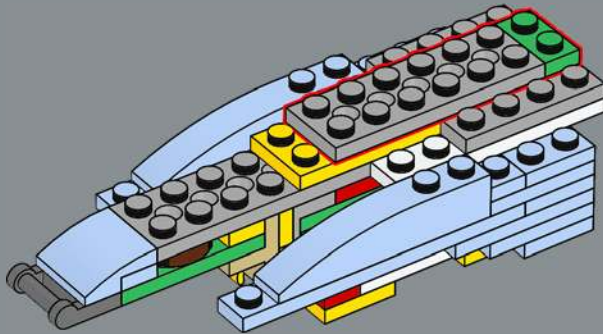

71

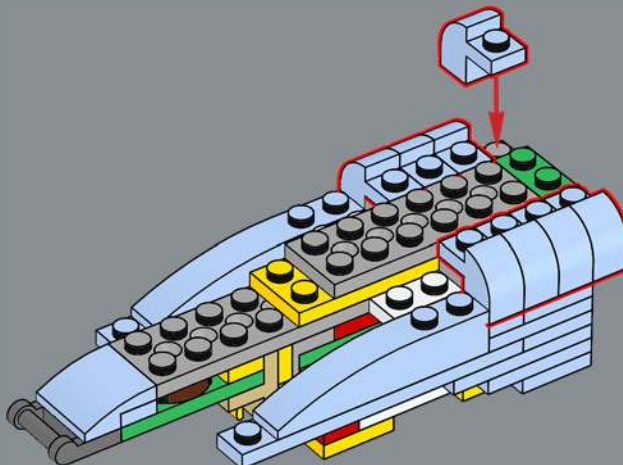

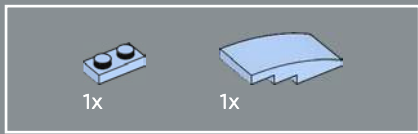

72

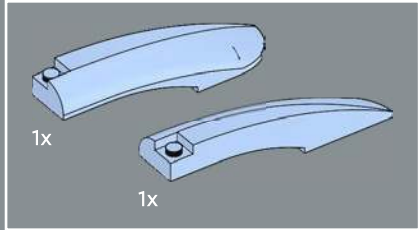
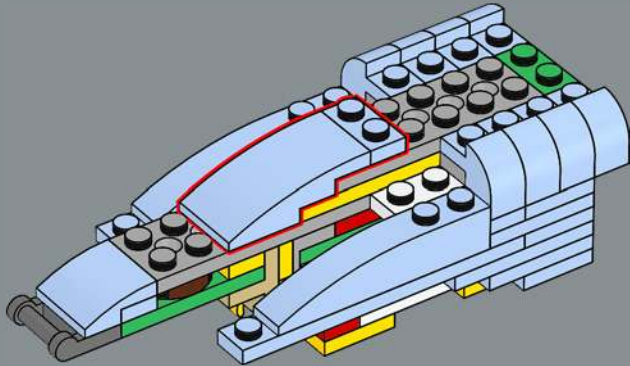

73

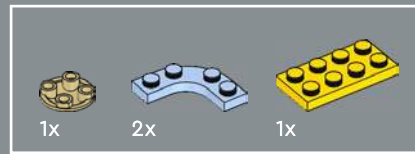
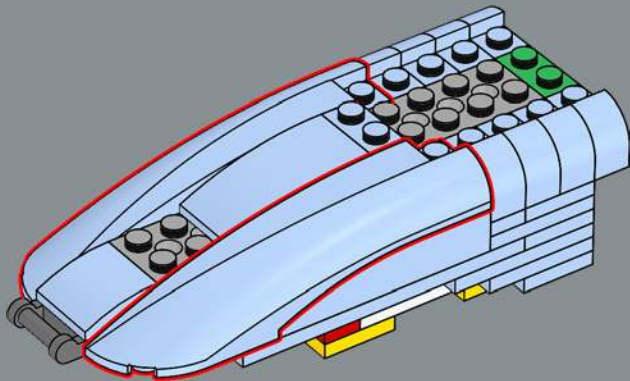

74

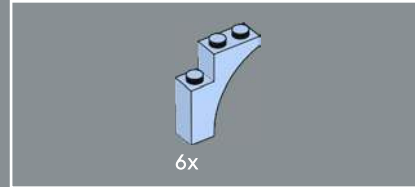
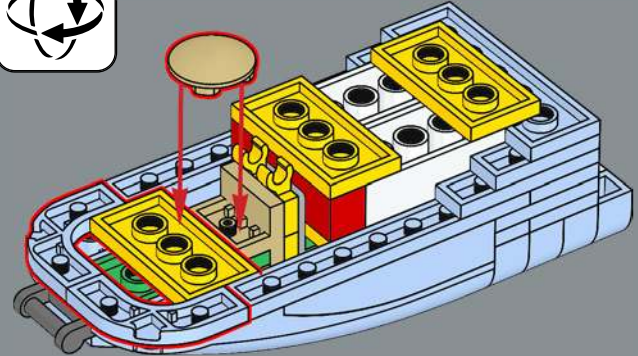

75

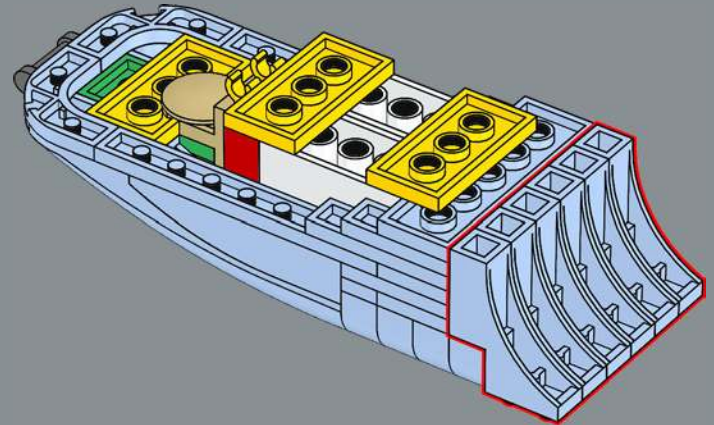



3x

76

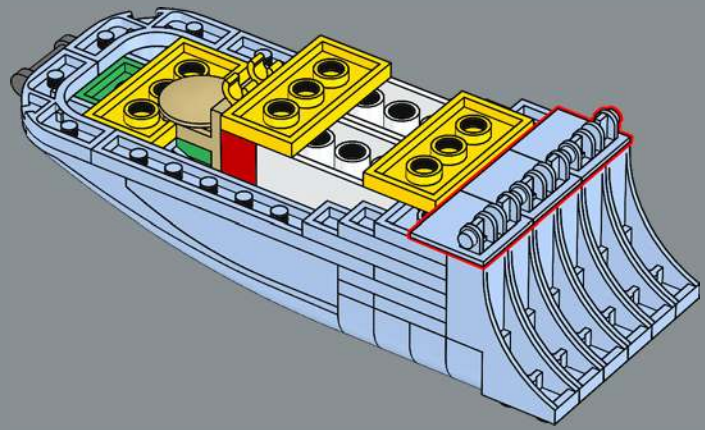

77

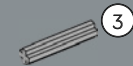
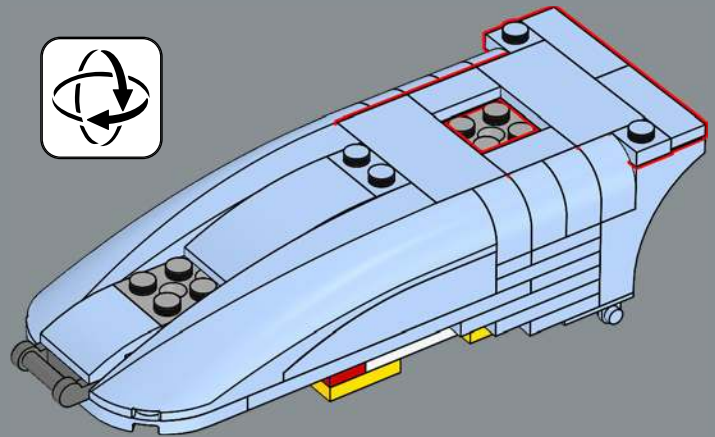

2x



3

1:1

78

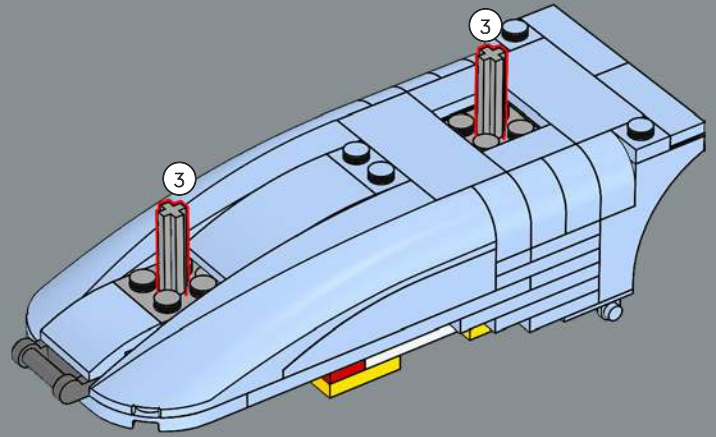

4x

2x

79

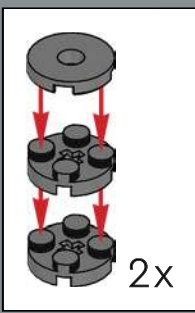

2x

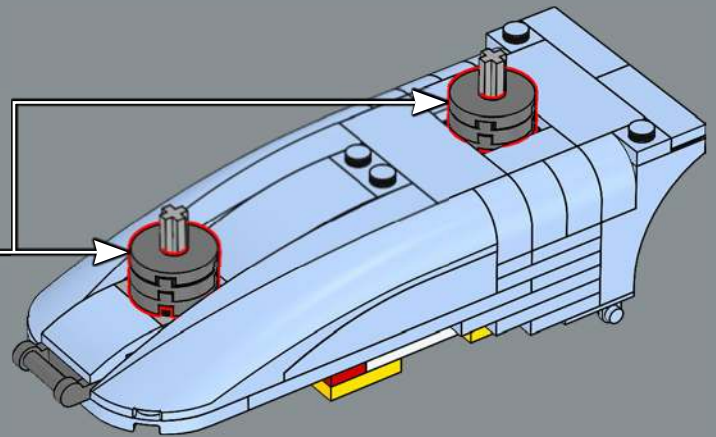

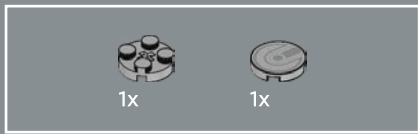

80

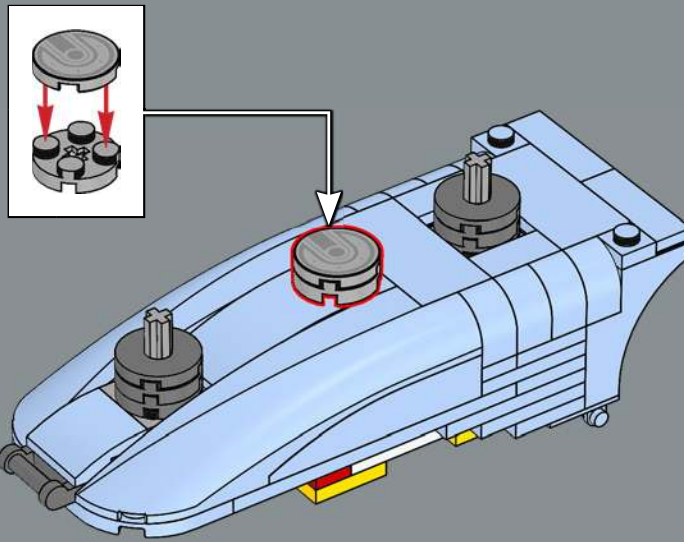

81

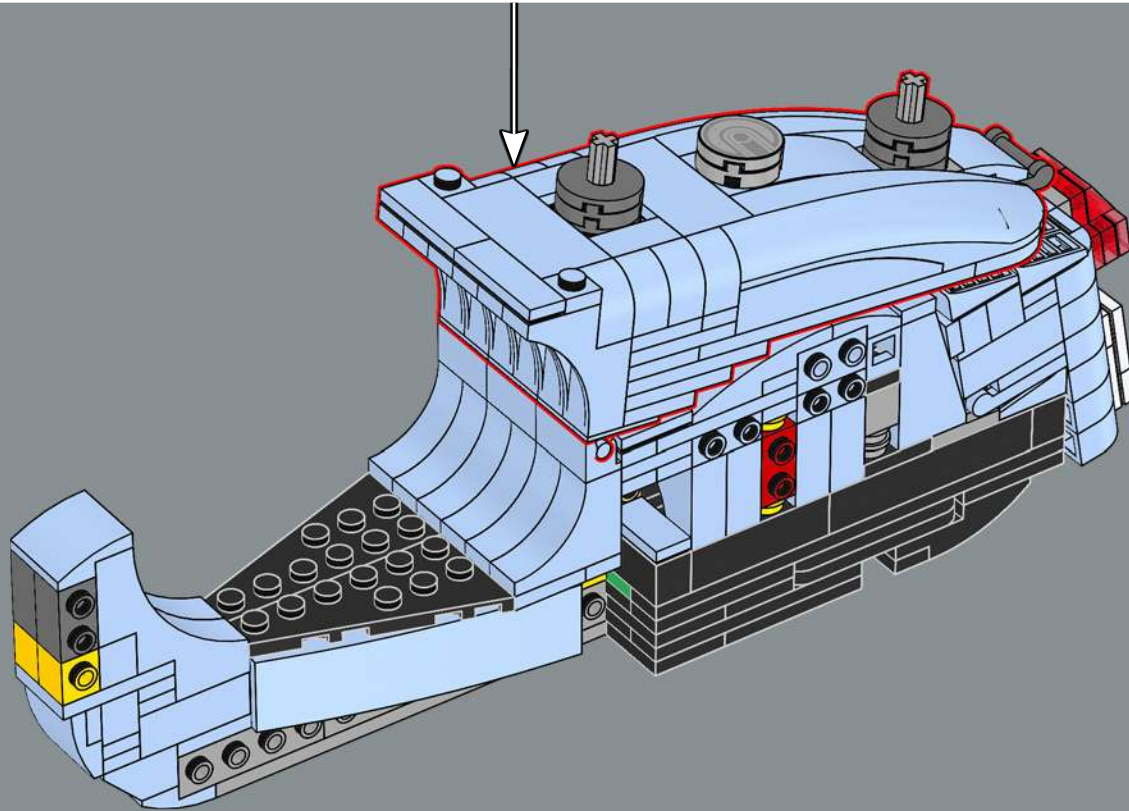

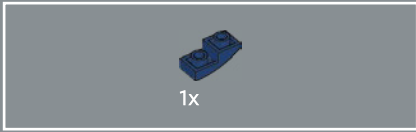
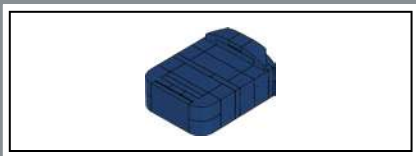

82

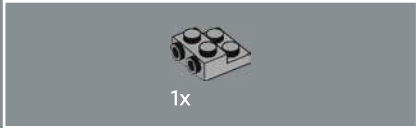
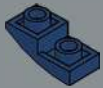

83

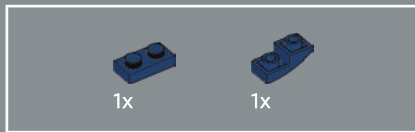
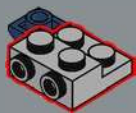

84

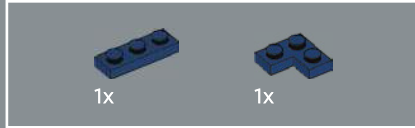
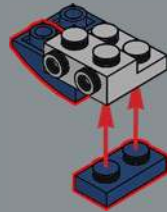

85

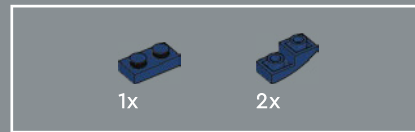
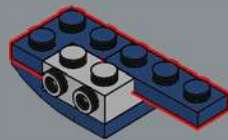

86

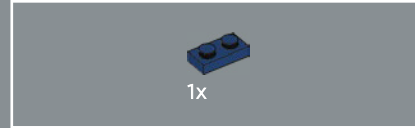
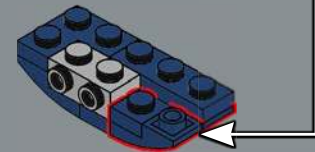
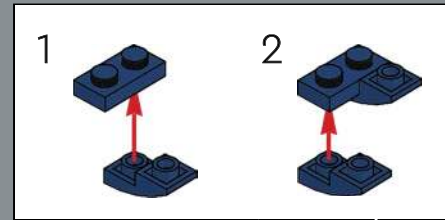

87

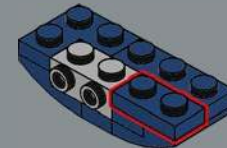

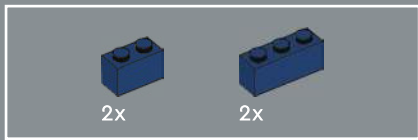

88

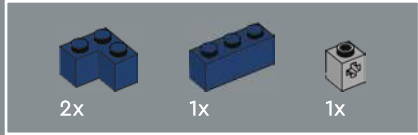
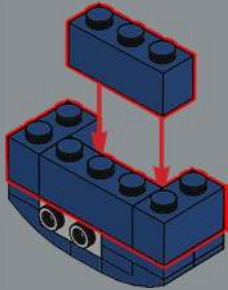

89

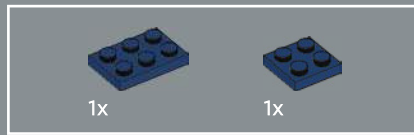
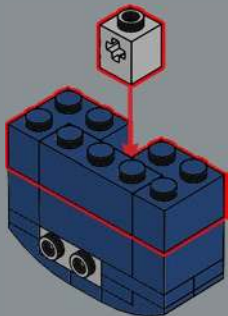

90

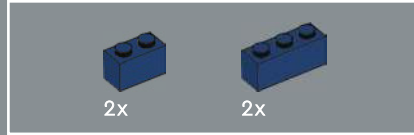
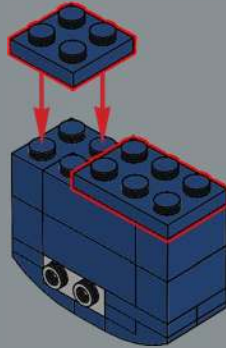

91

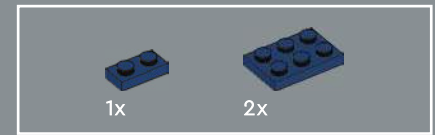
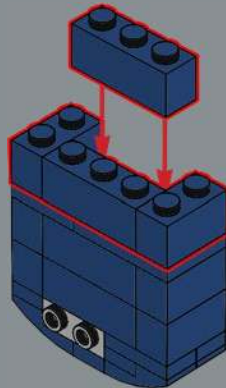

92

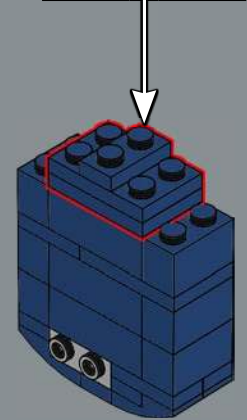
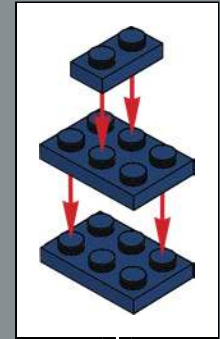



4x

93

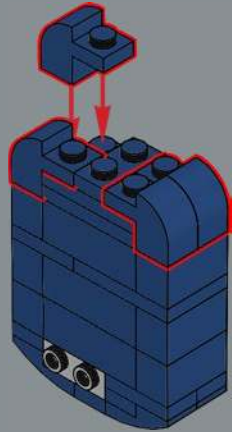

1x



1x

94

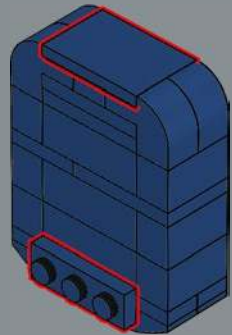

1x



1x



1x

95

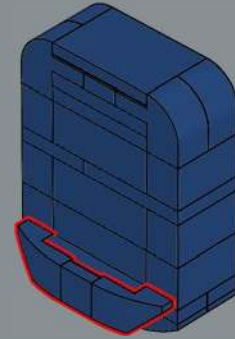

96

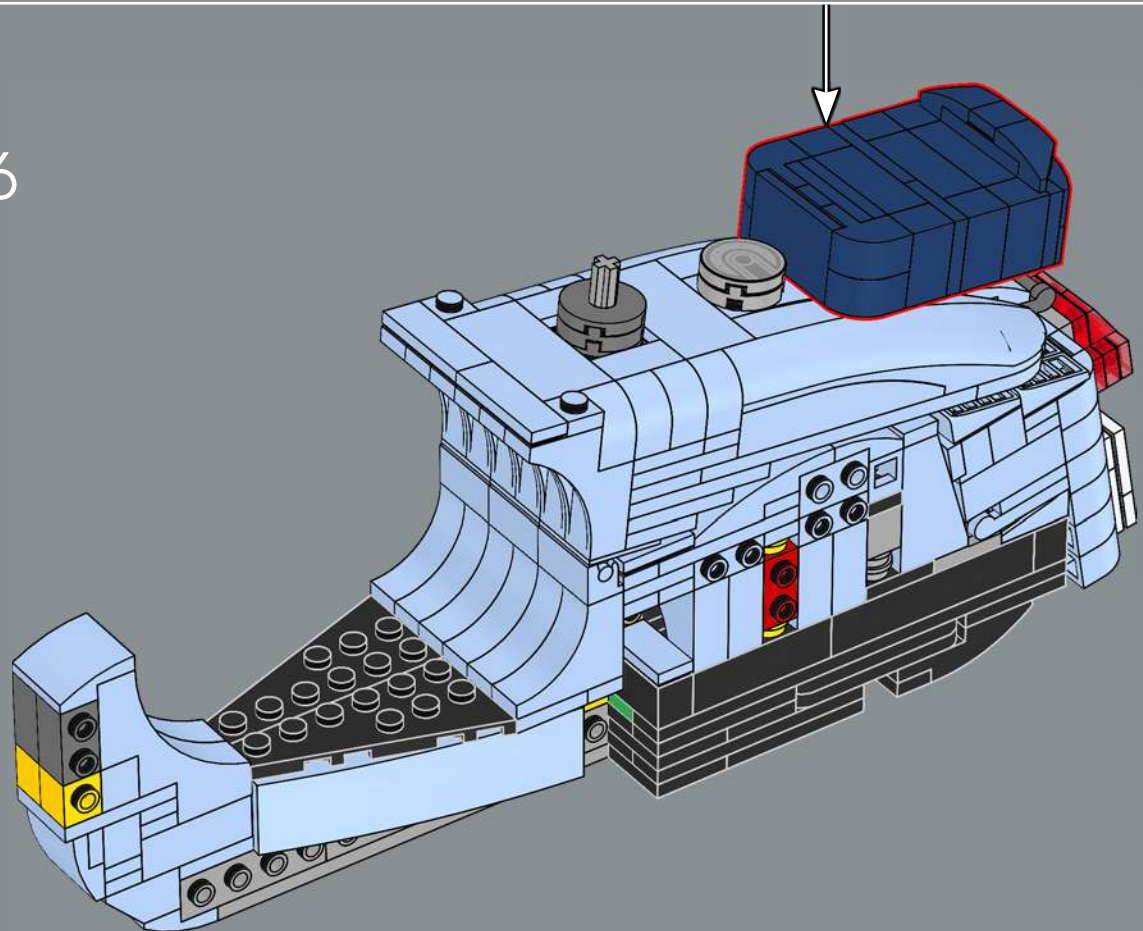

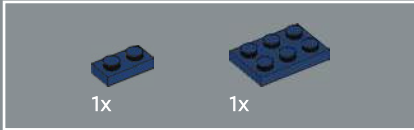
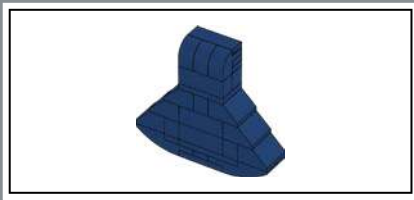

97

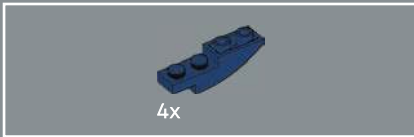
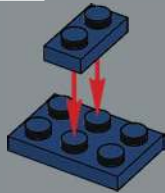

98

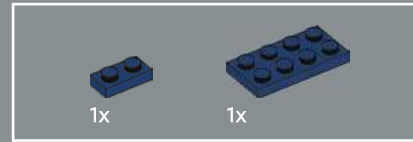
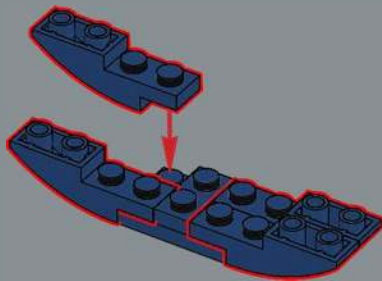

99

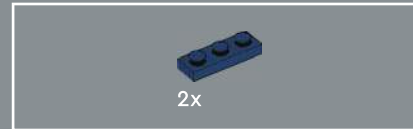
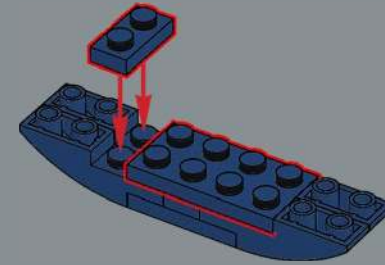

100

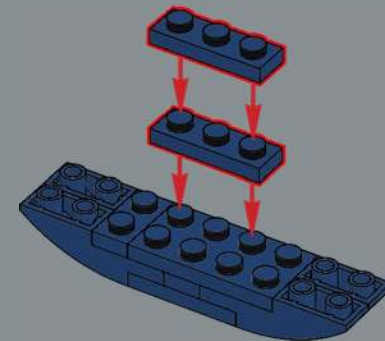

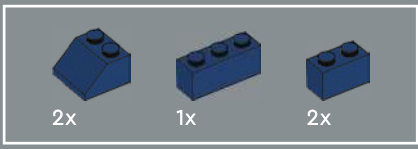

101

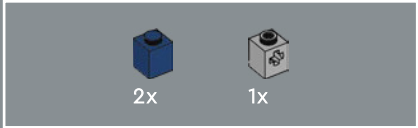
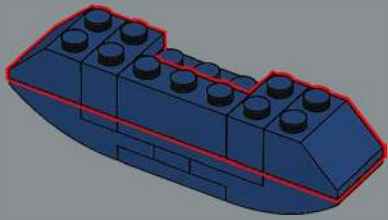

102

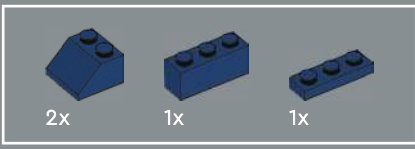
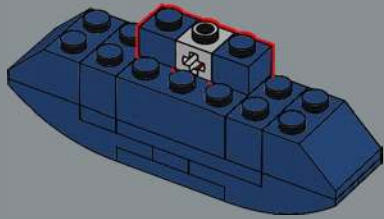

103

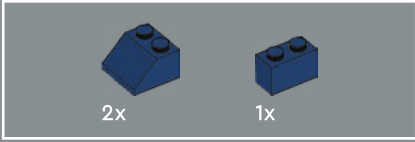
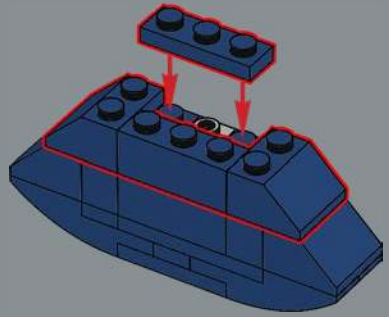

104

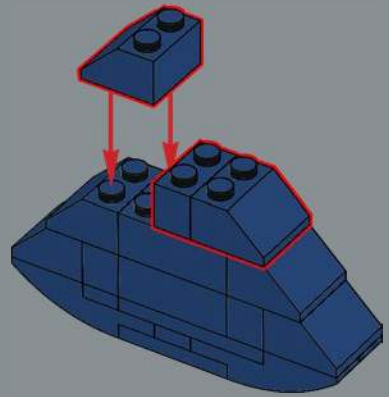

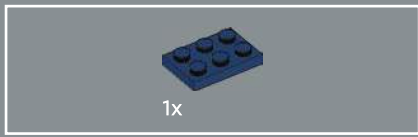

105

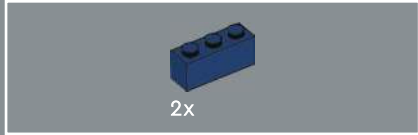
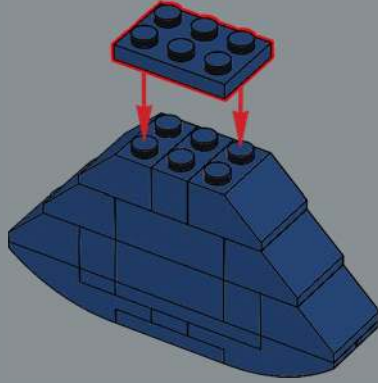

106

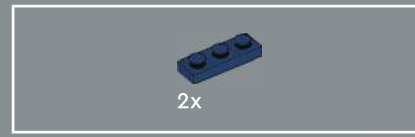
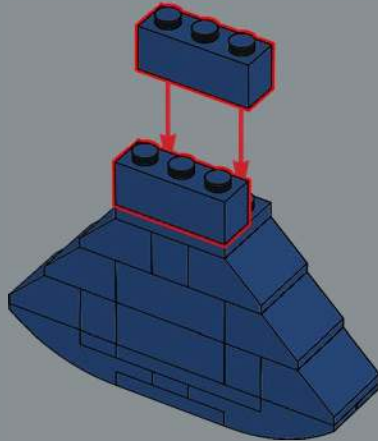

107

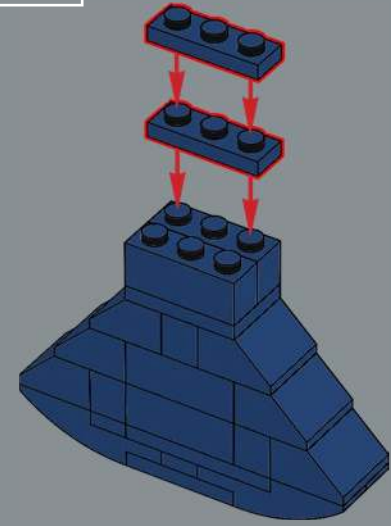

108

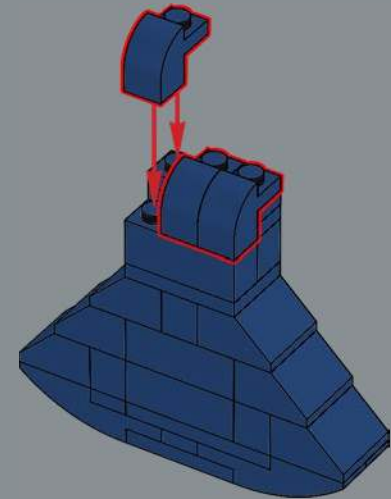

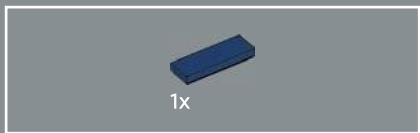

109

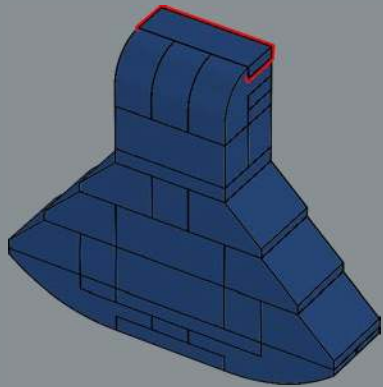

110

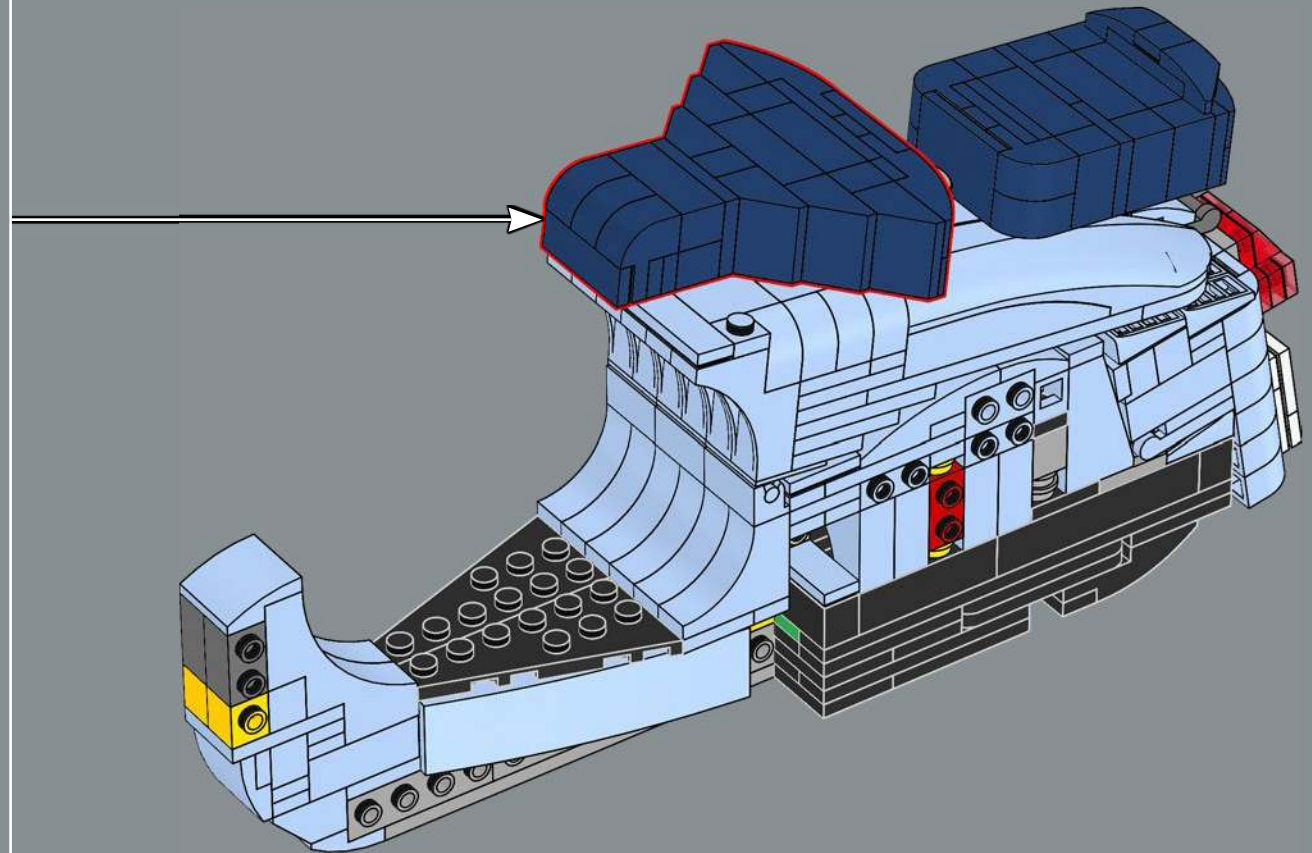

Over 100,000 people are members of Piaggio's Vespa Club, which has chapters in cities all over the world.

Oltre 100.000 persone sono iscritte ai Vespa Club Piaggio, che ha sedi nelle città di tutto il mondo.

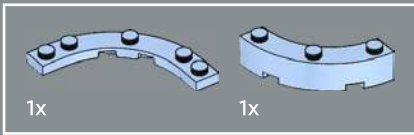
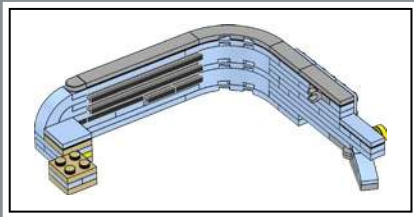
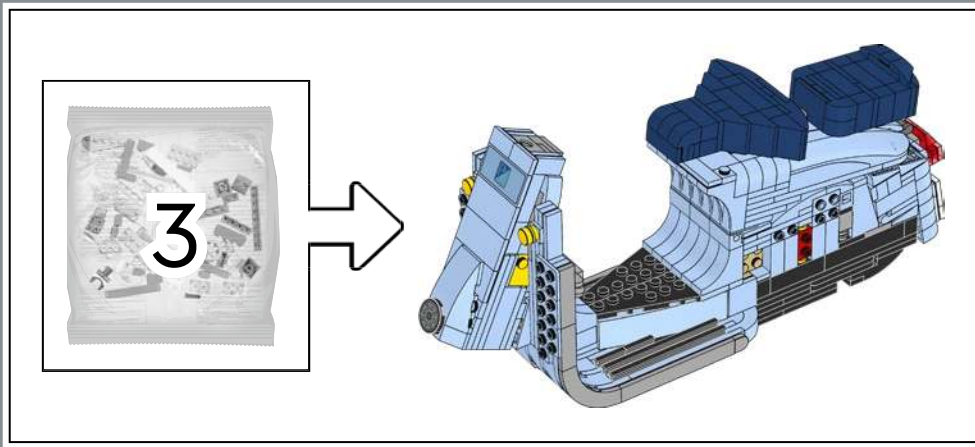

111

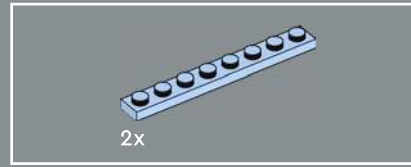
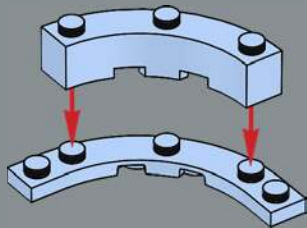

112

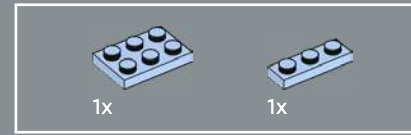
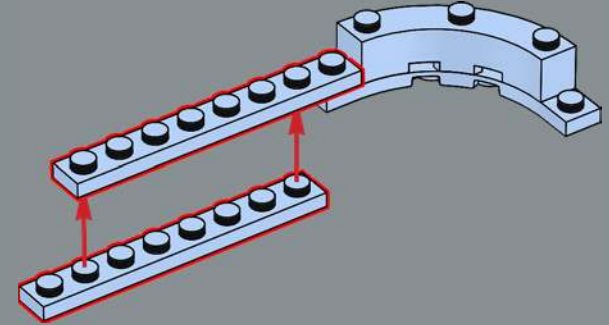

113

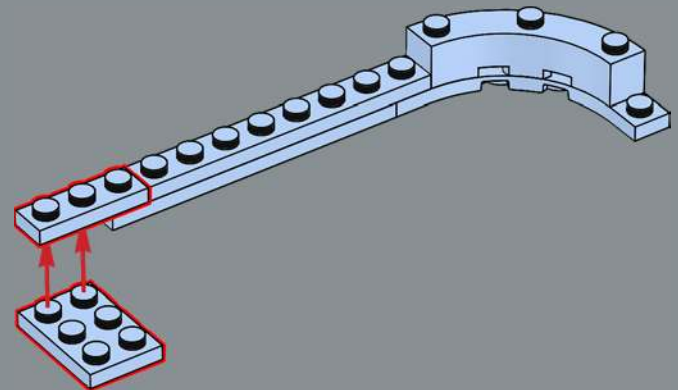

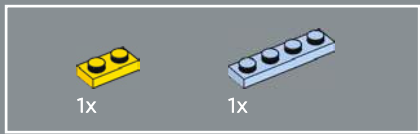

114

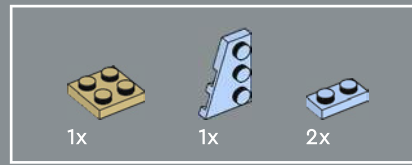
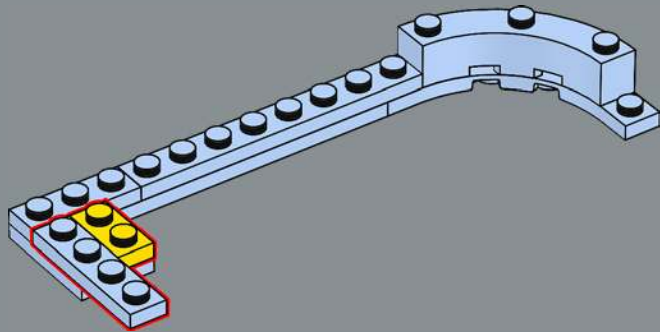

115

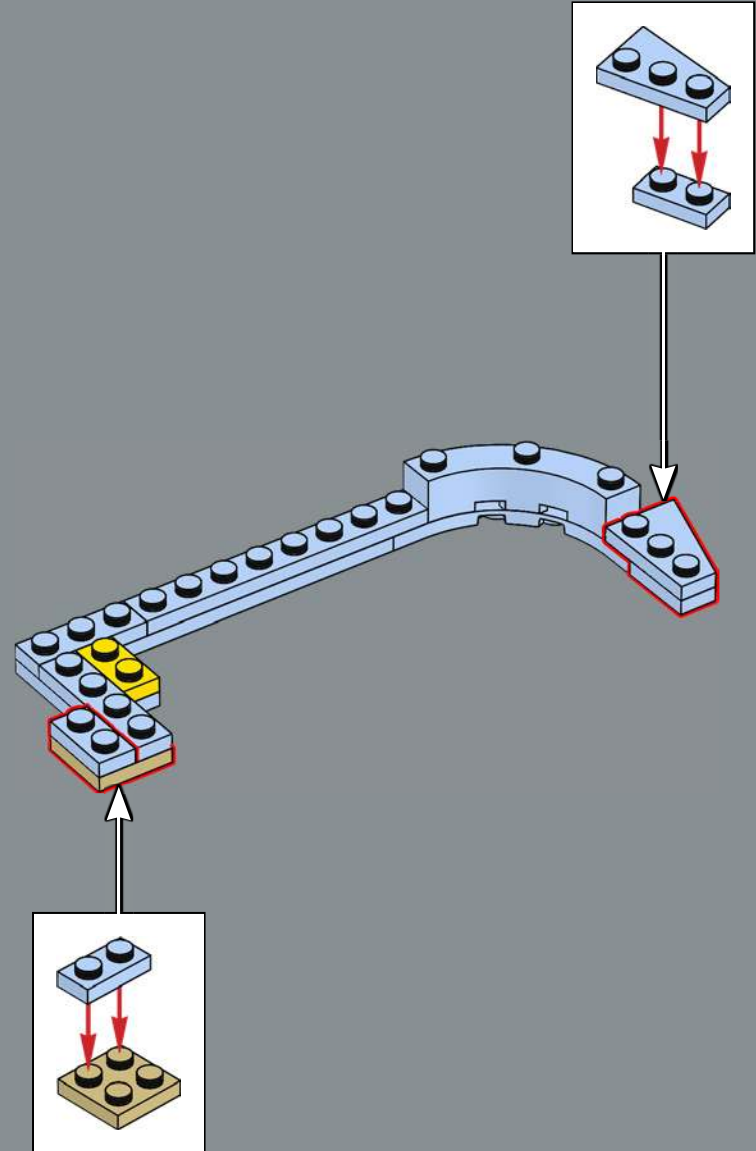

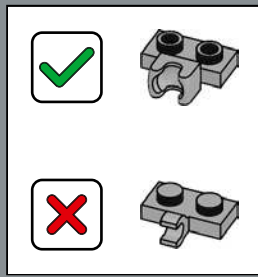
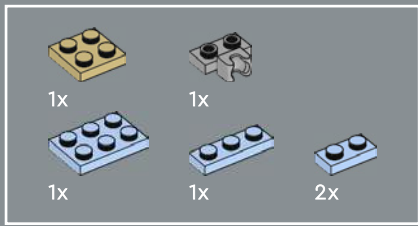

116

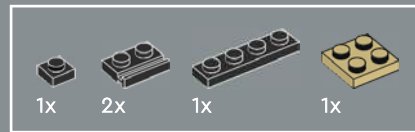
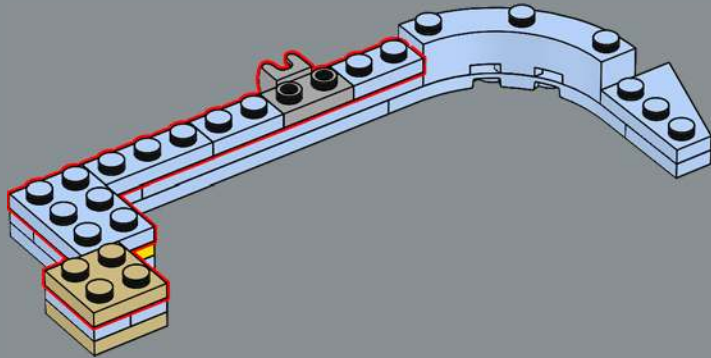

117

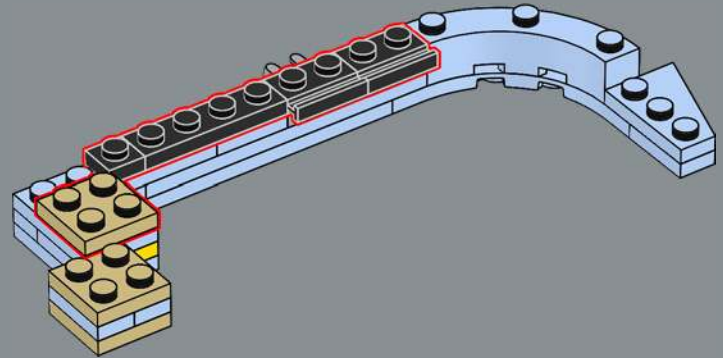

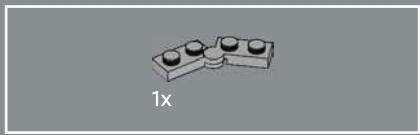

118

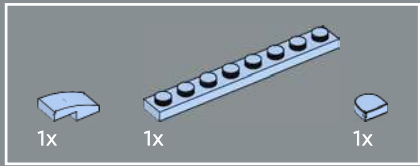
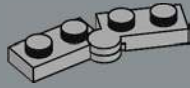

119

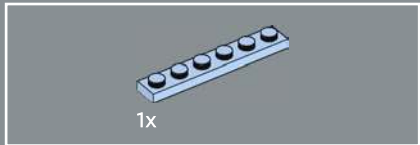
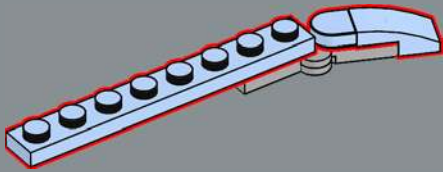

120

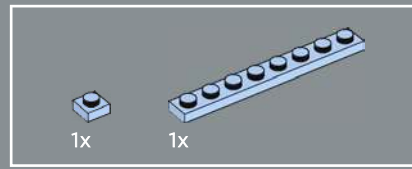
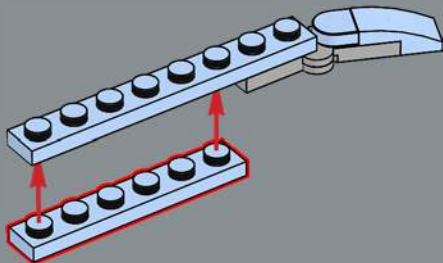

121

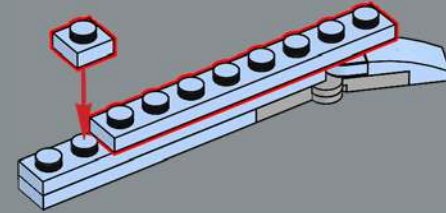

122

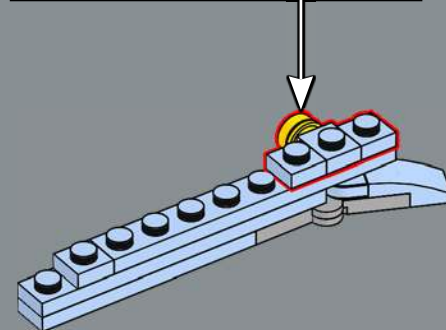



123

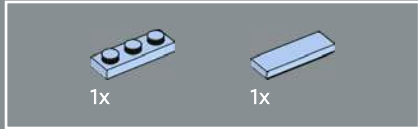
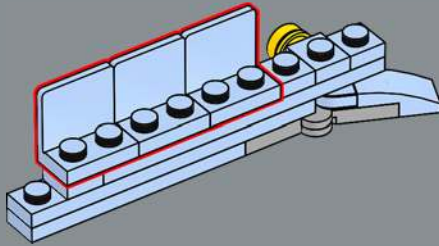

124

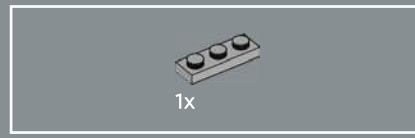
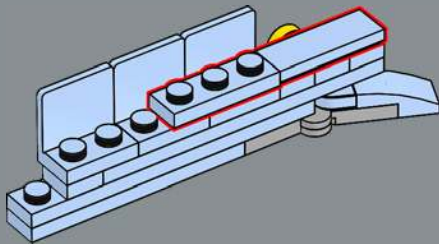

125

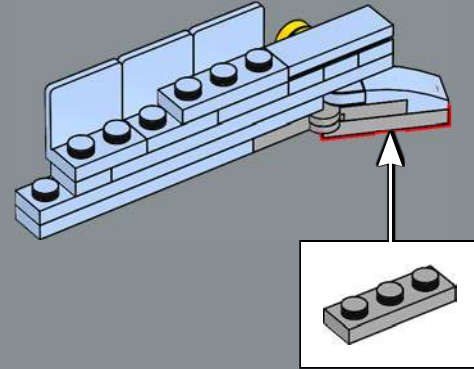

126

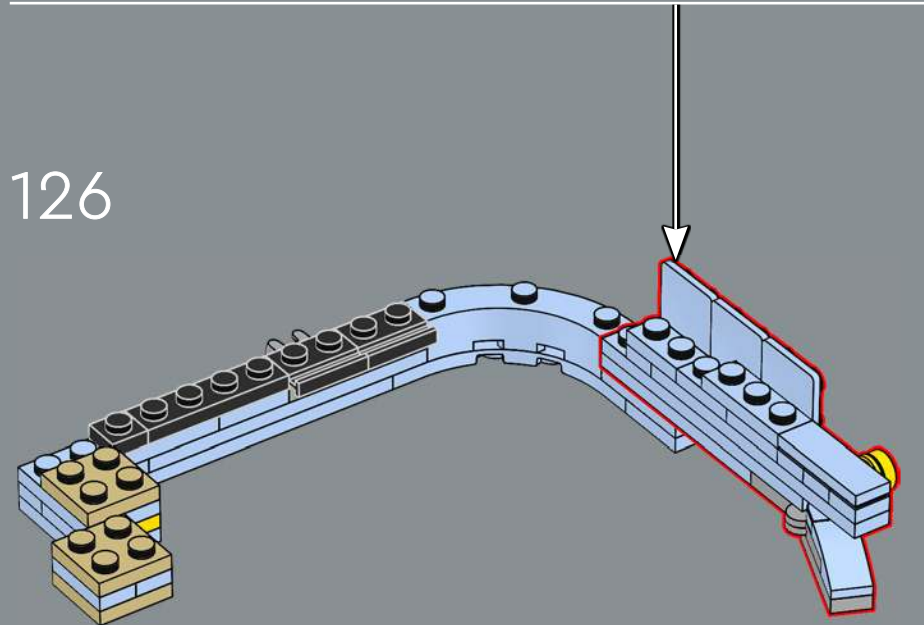

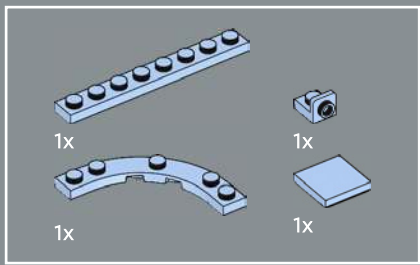

127

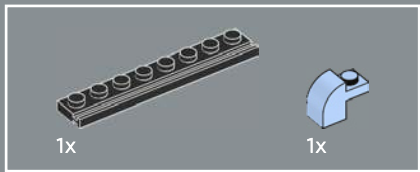
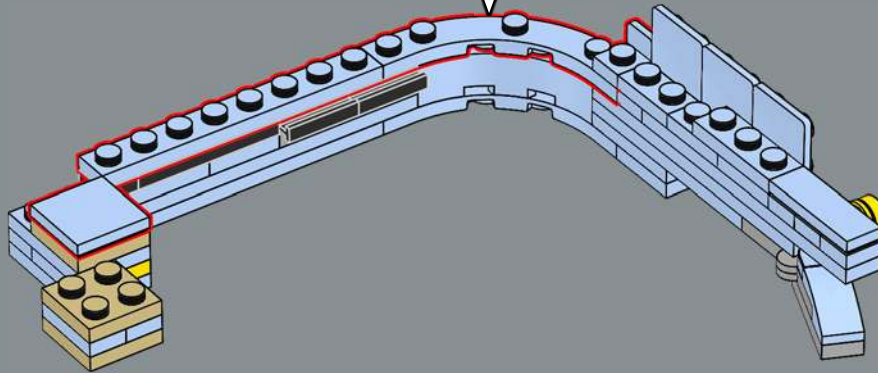
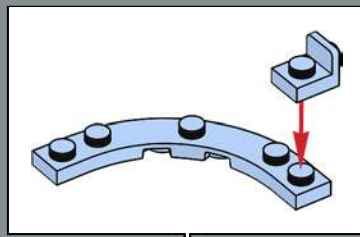

128

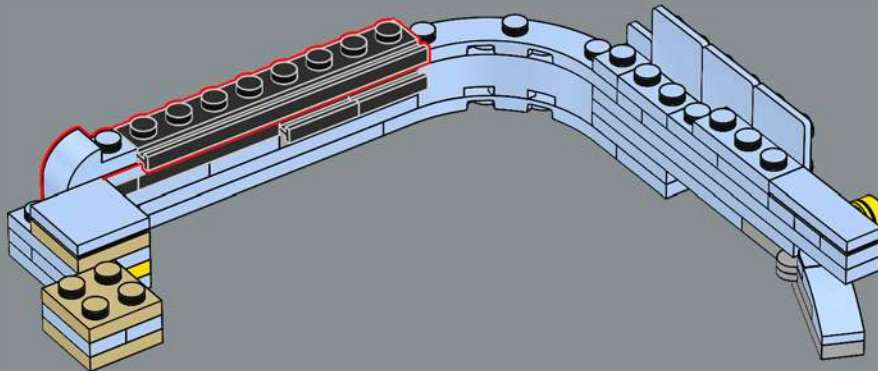

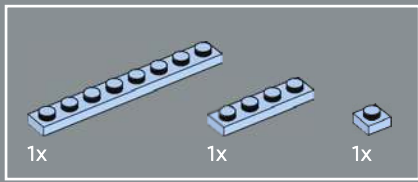

129

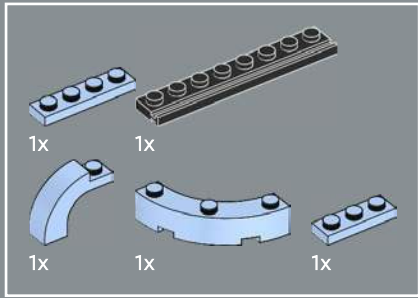
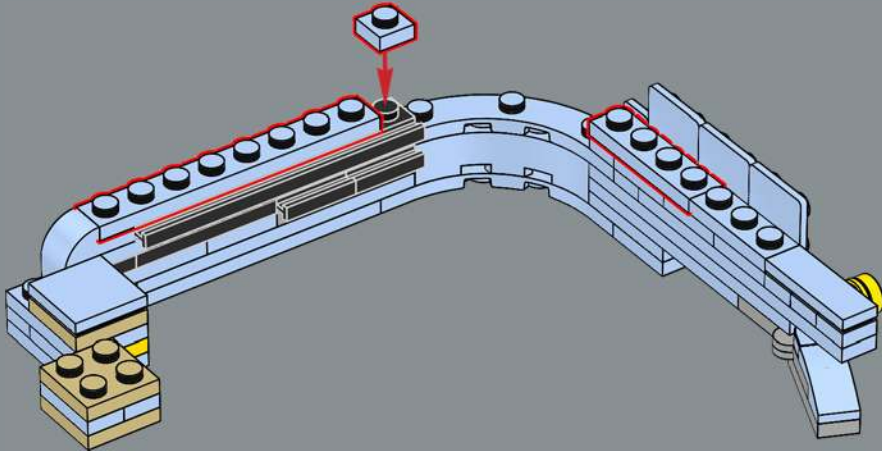

130

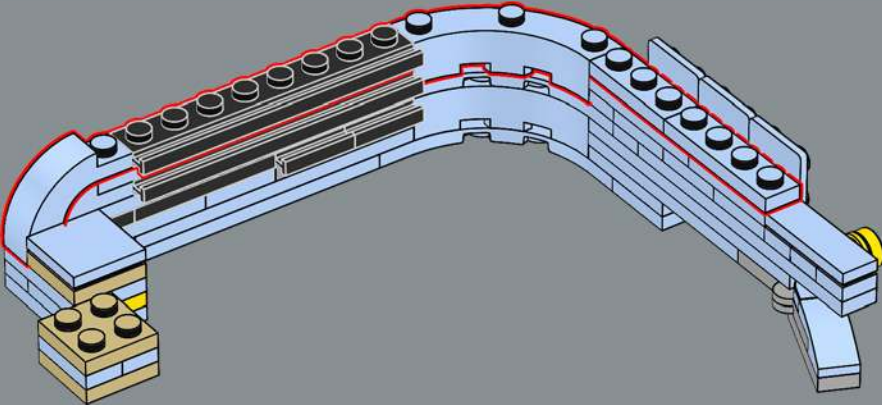

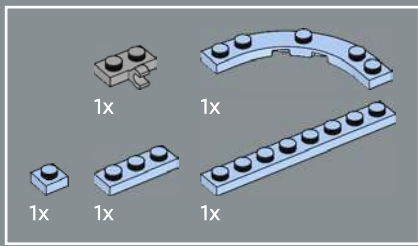

131

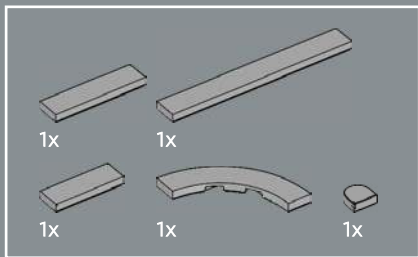
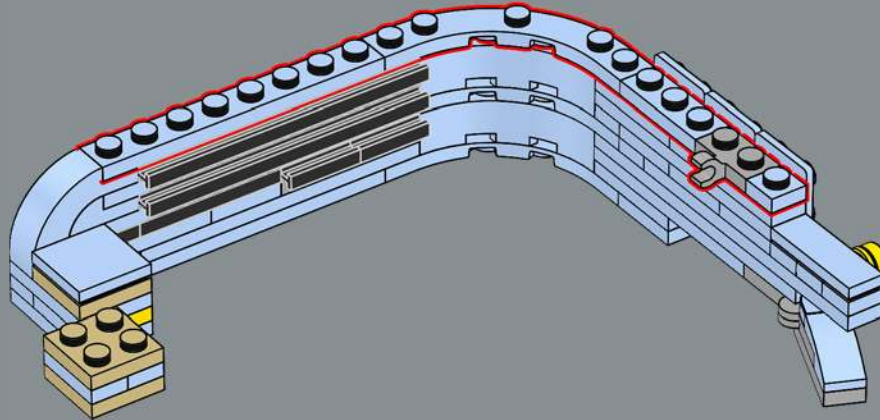
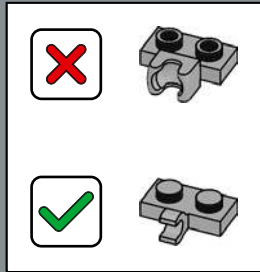

132

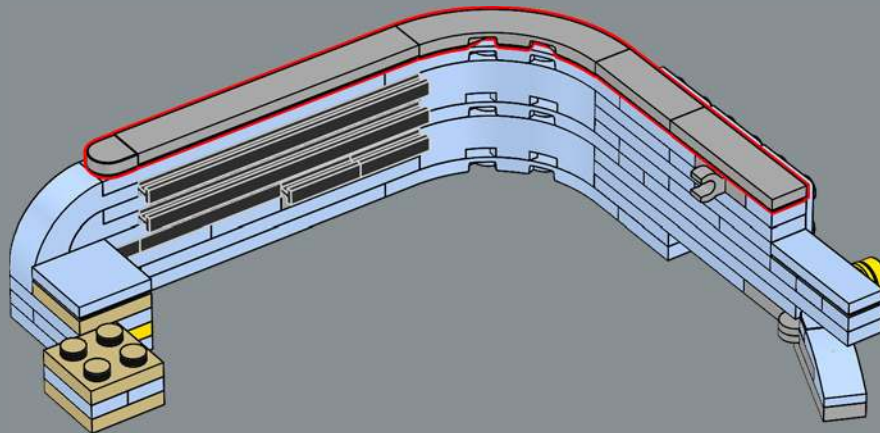

133

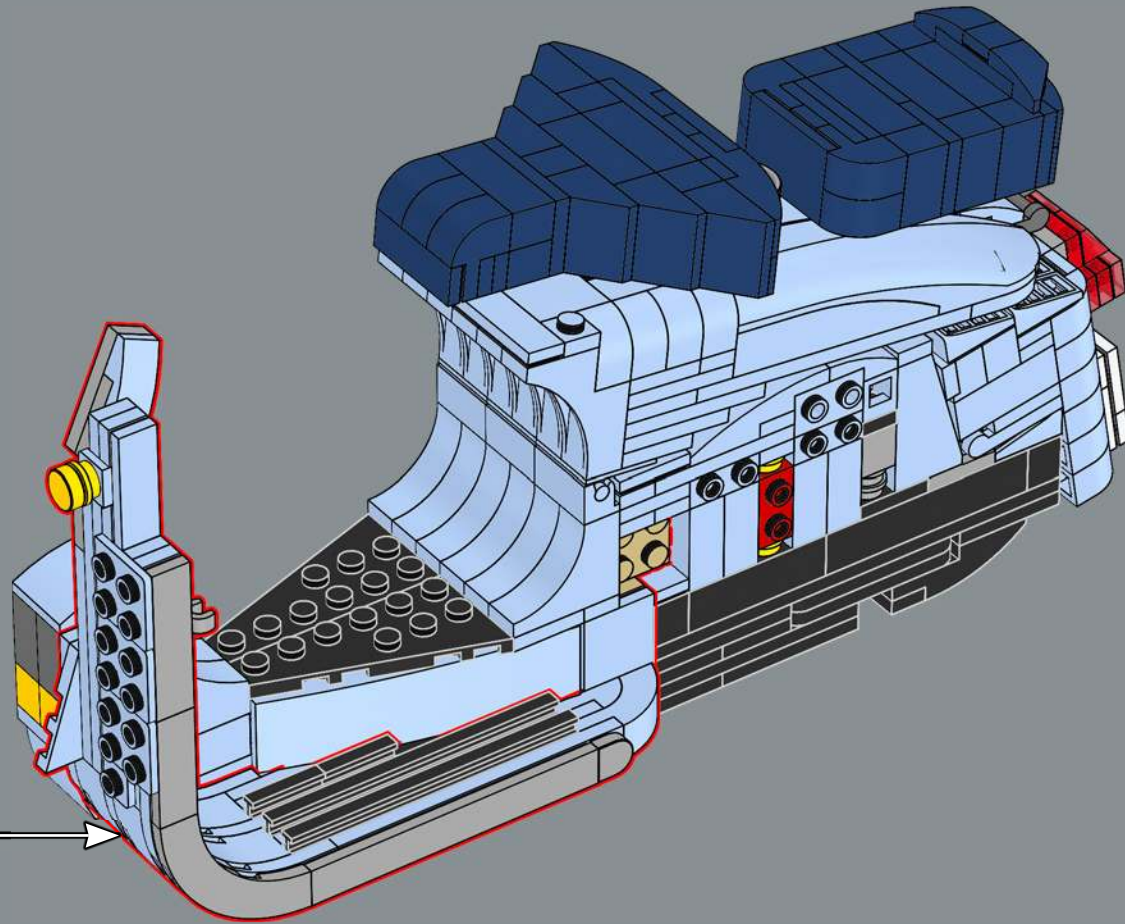

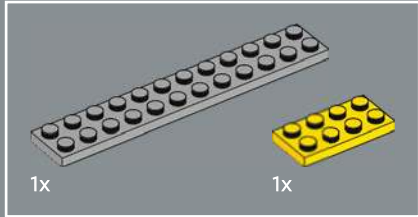
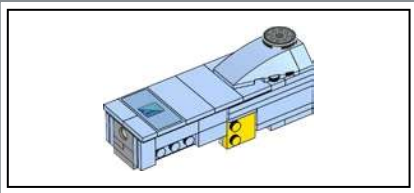

134

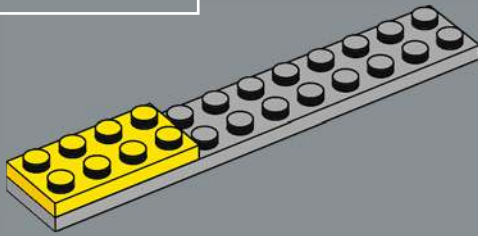

135

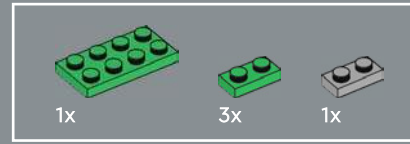
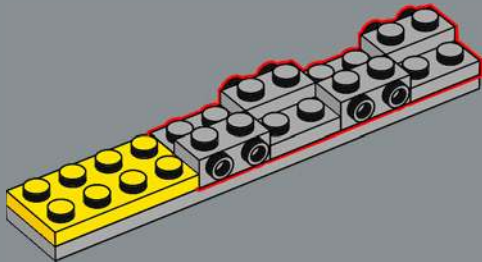

136

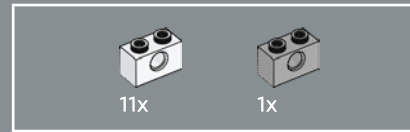
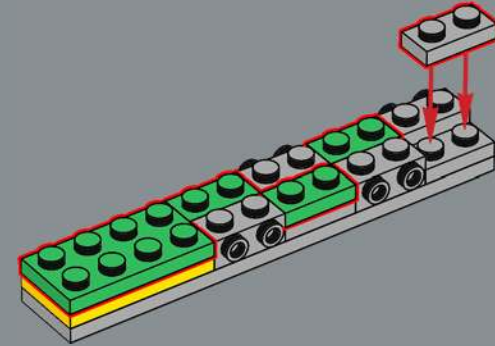

137

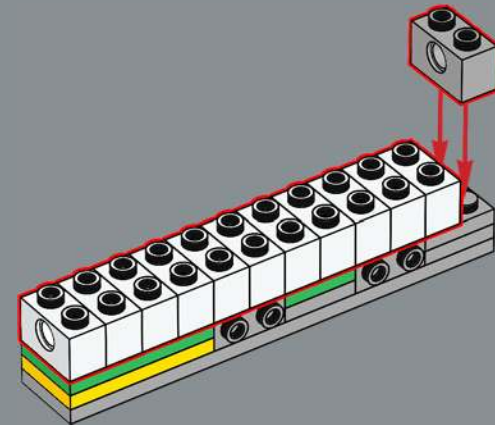

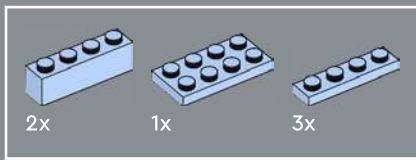

138

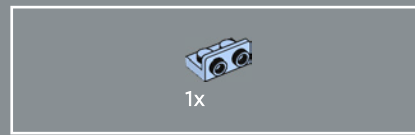
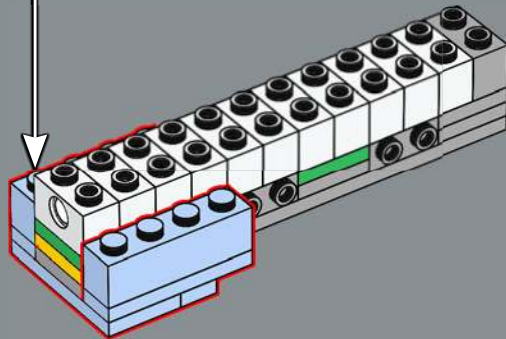
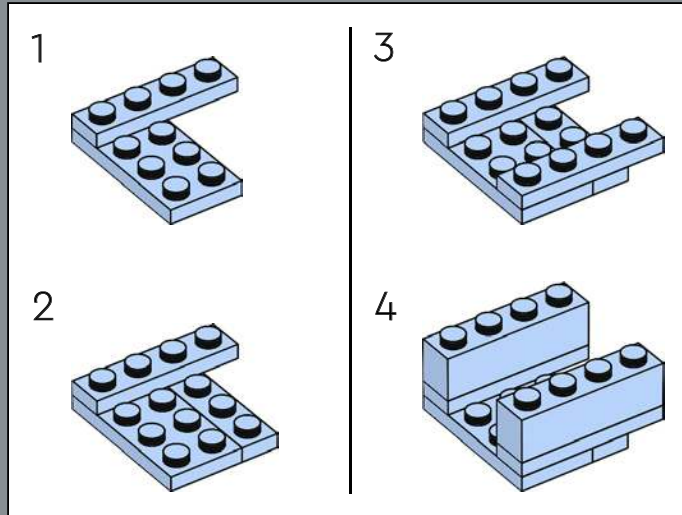

139

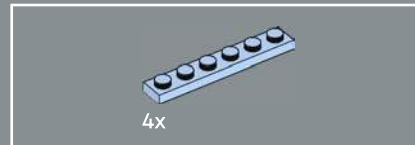
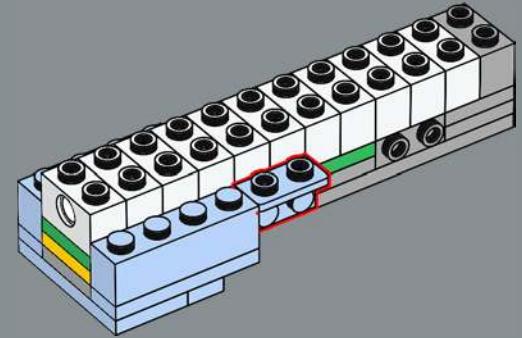

140

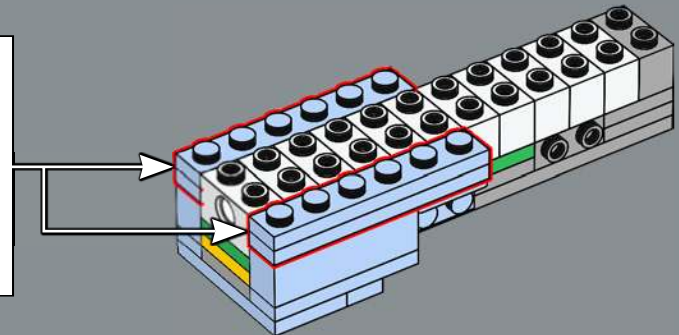
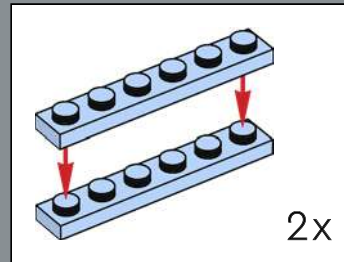

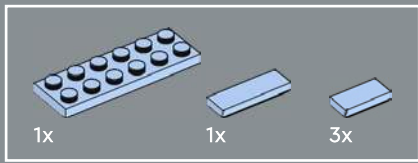

141

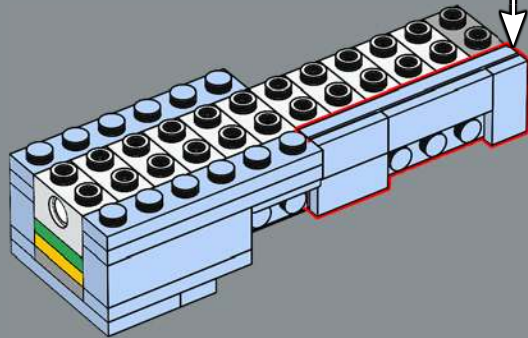
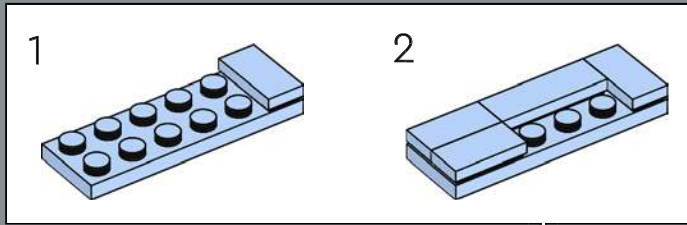

142

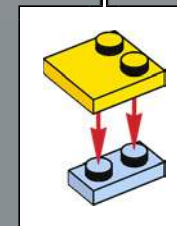
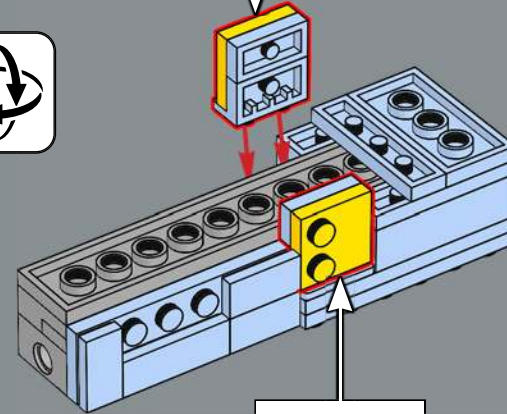
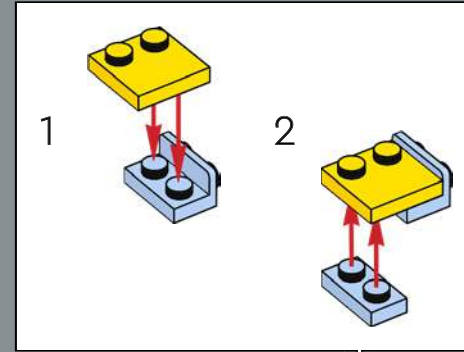

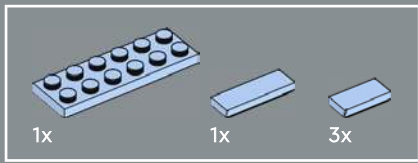

143

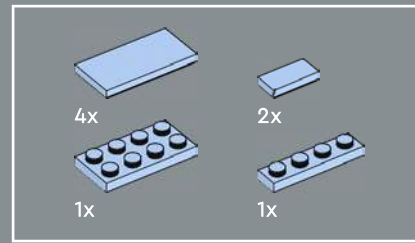
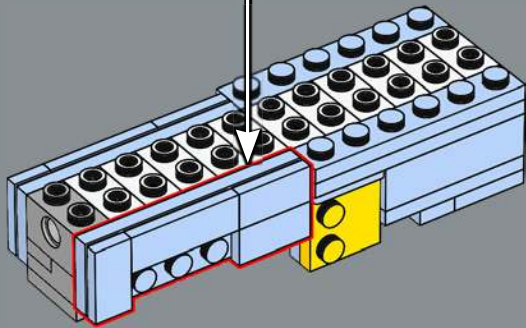
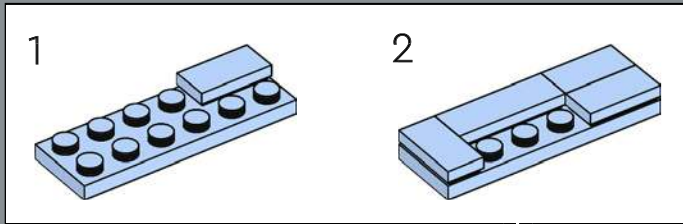

144

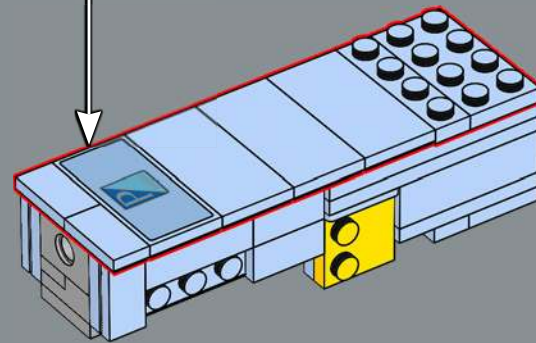
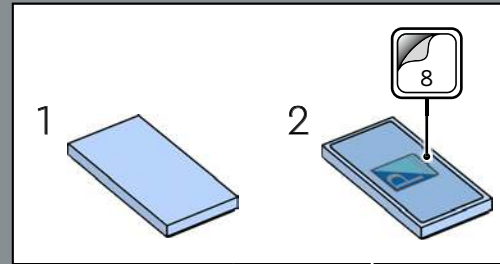

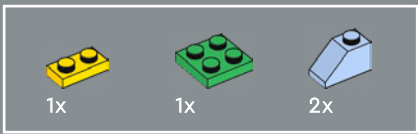

145

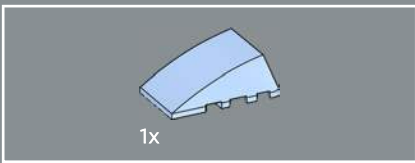
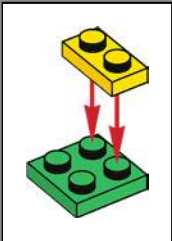
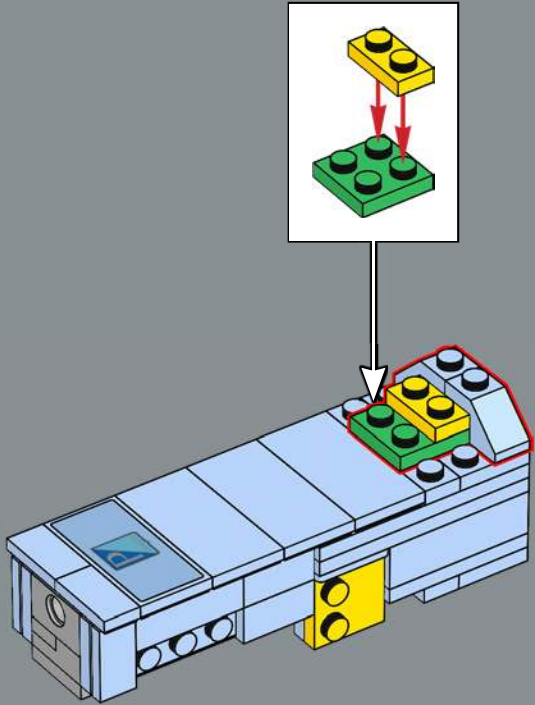

146

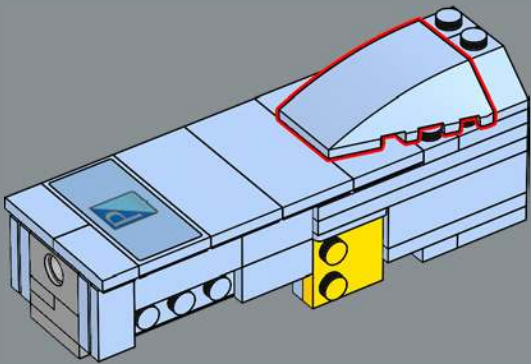



147

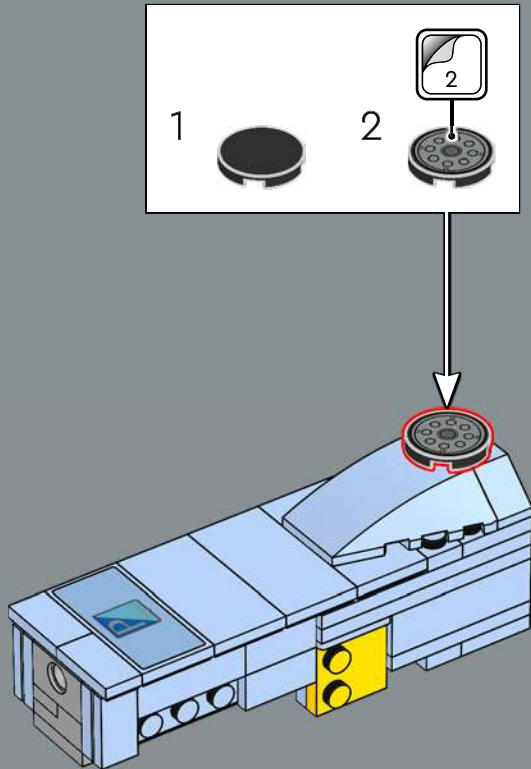

148

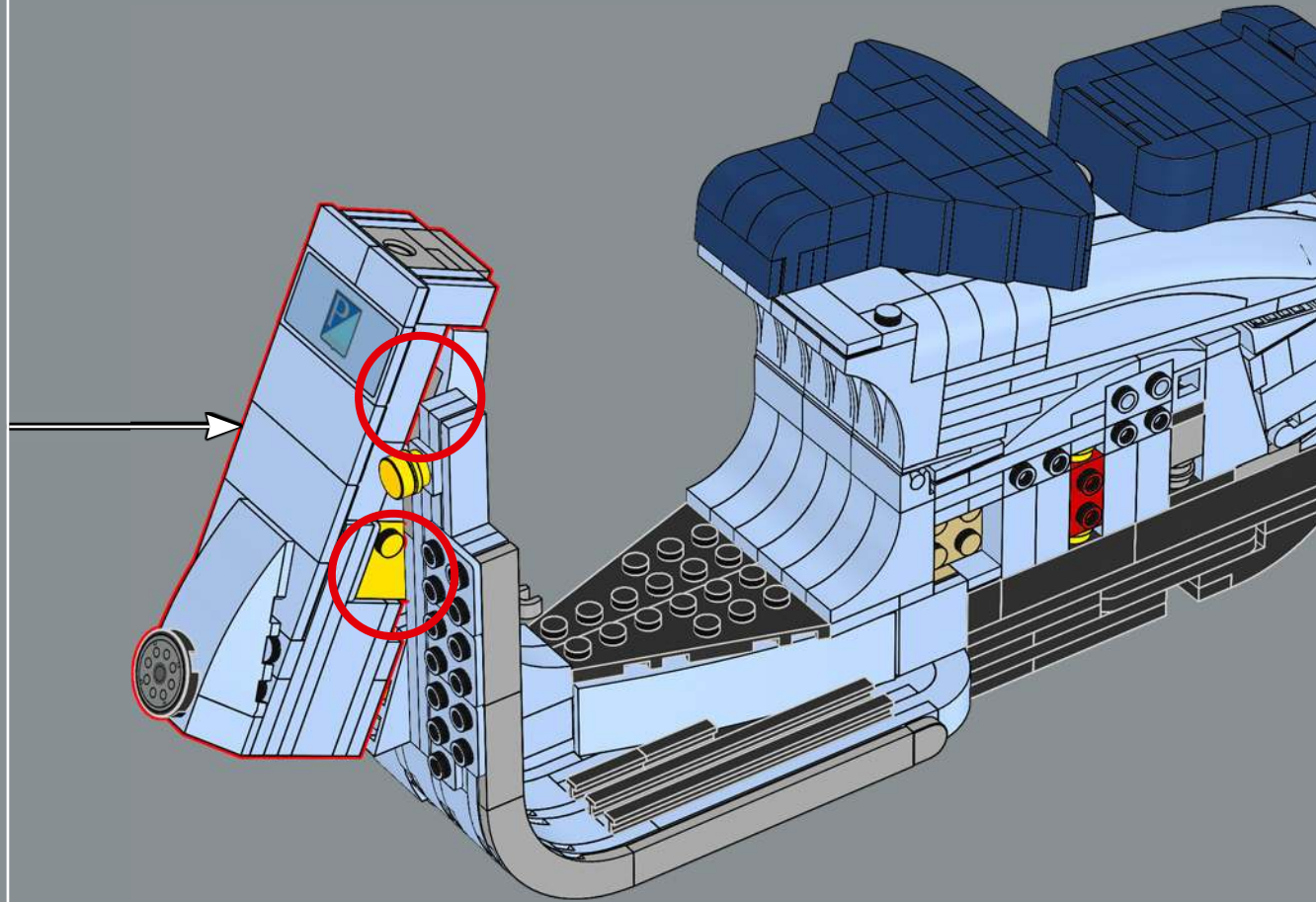

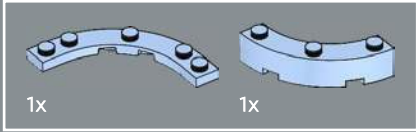
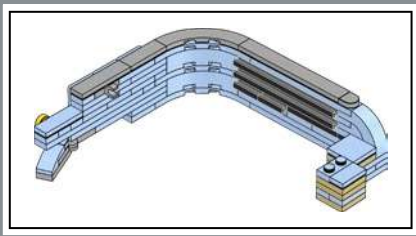

149

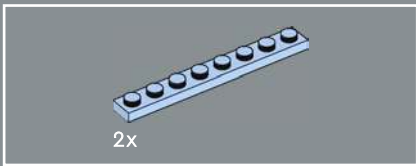
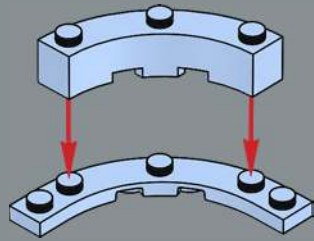

150

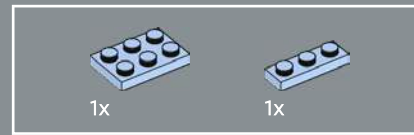
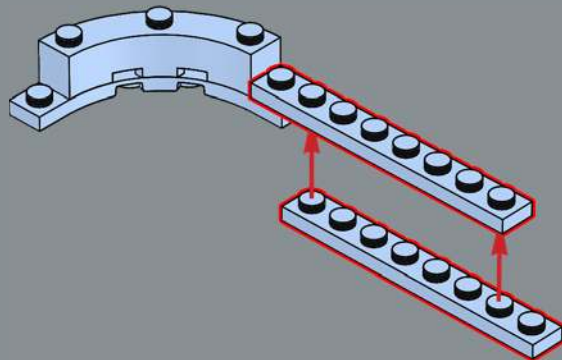

151

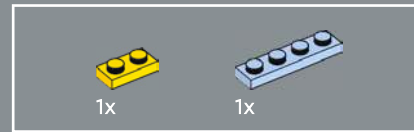
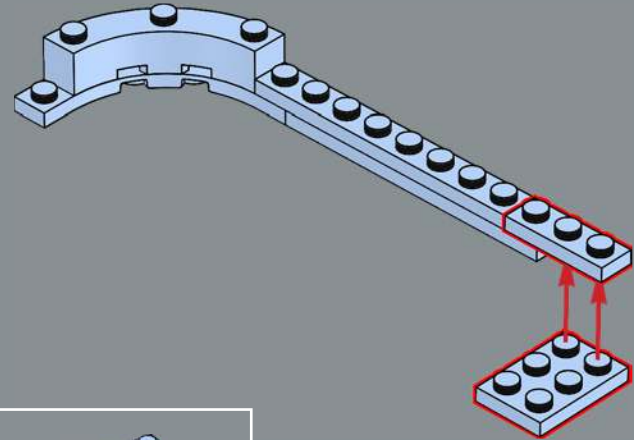

152

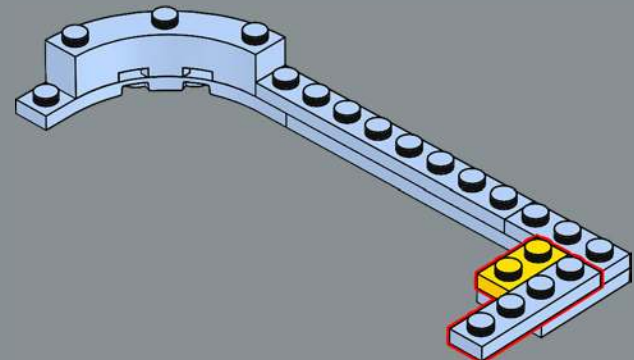

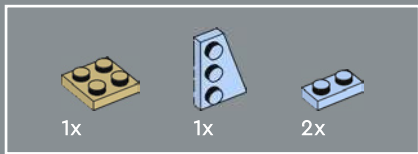

153

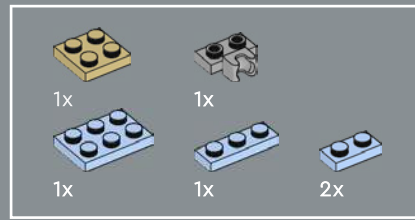
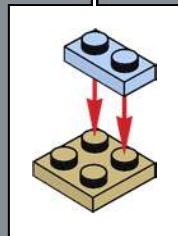
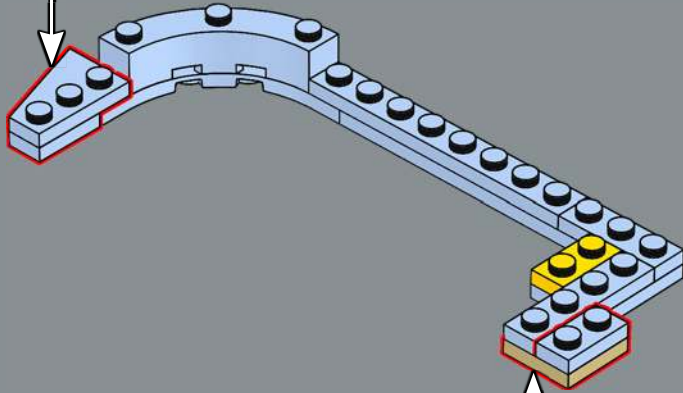
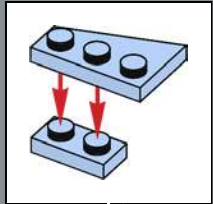

154

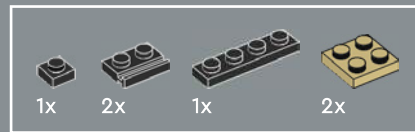
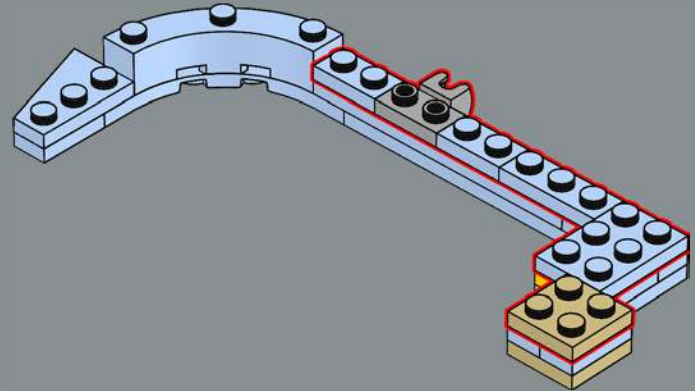
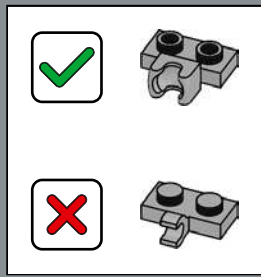

155

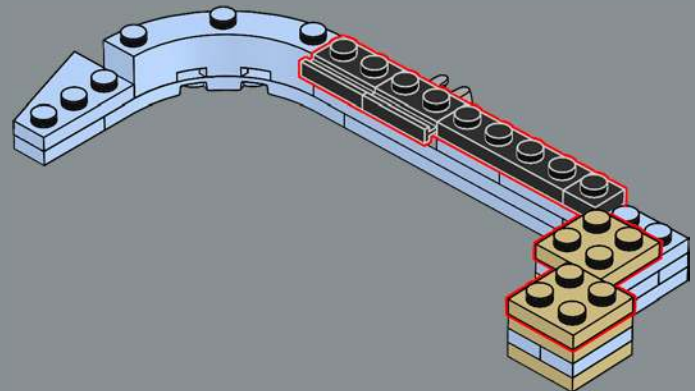

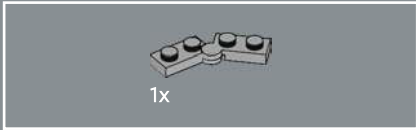
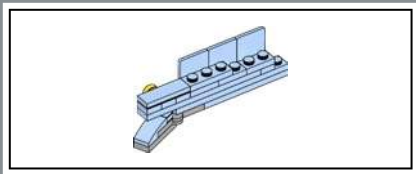

156

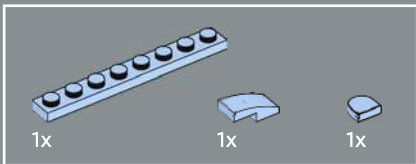
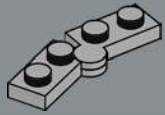

157

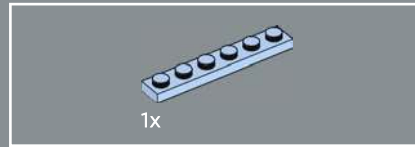
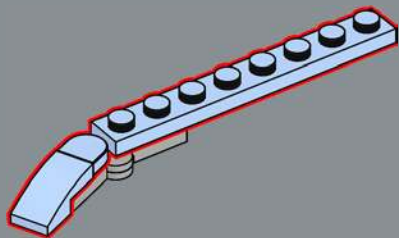

158

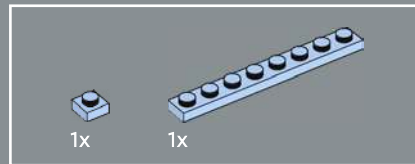
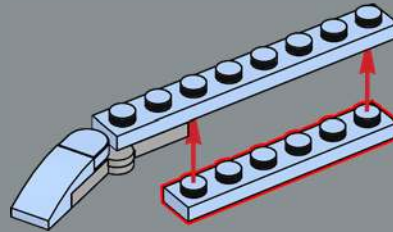

159

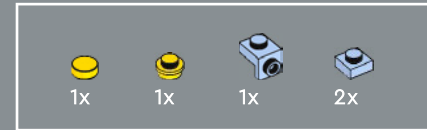
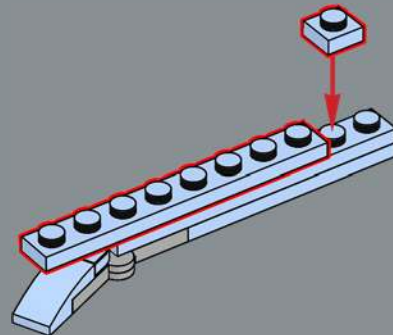

160

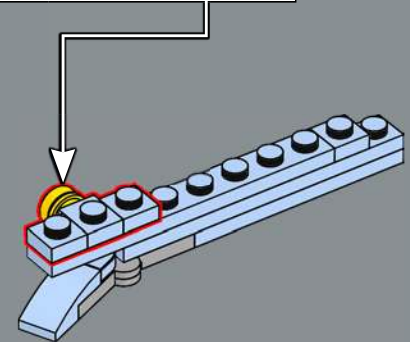
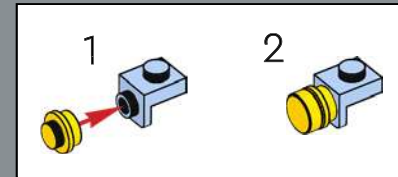



161

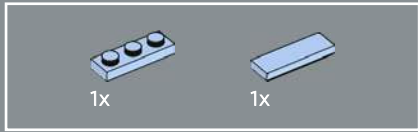
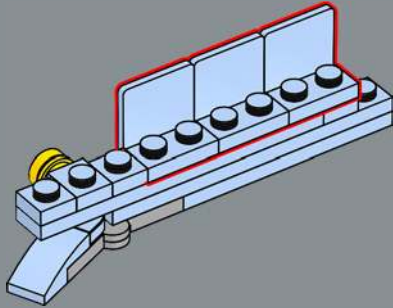

162

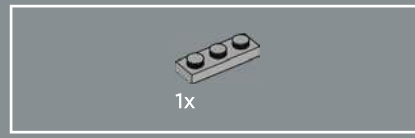
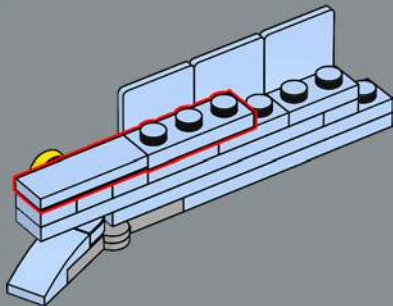

163

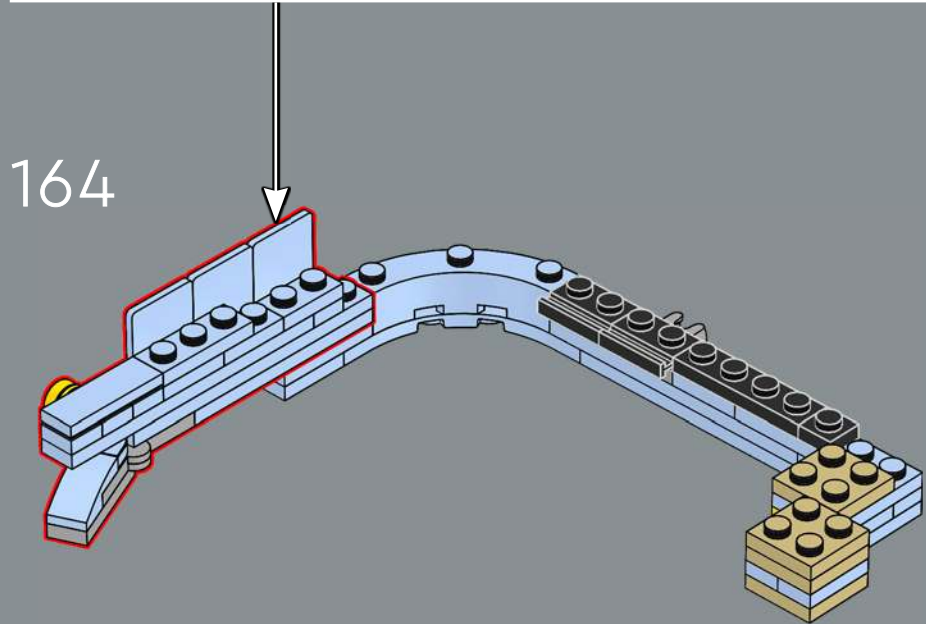
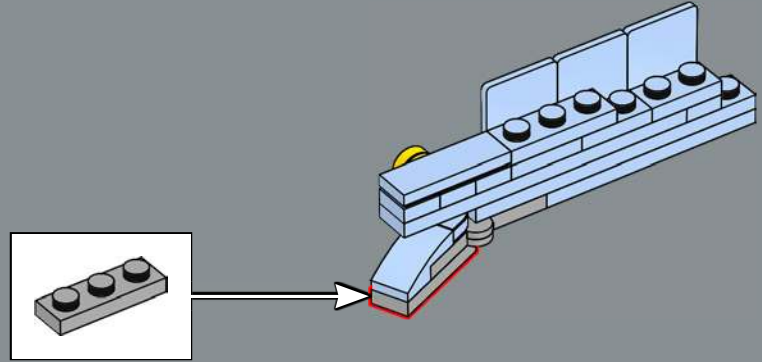

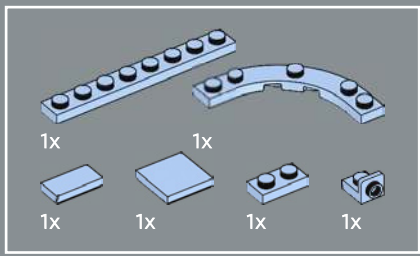

165

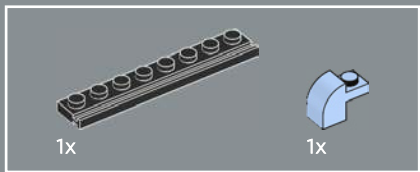
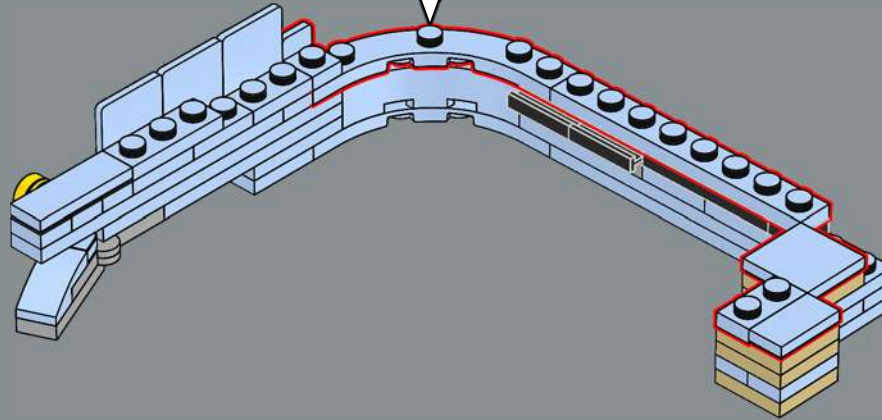
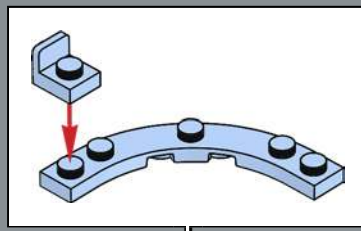

166

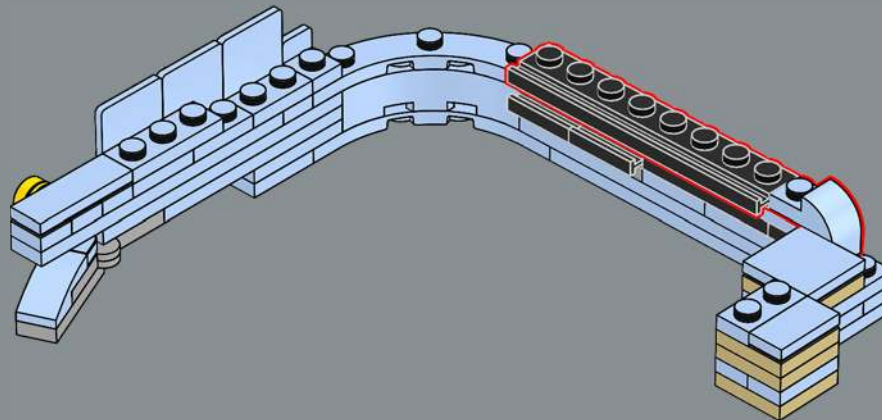



167

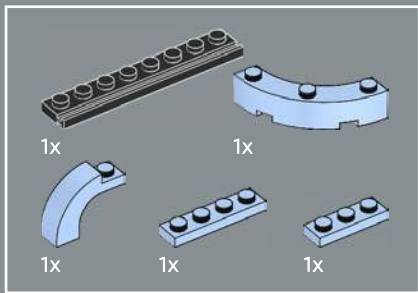
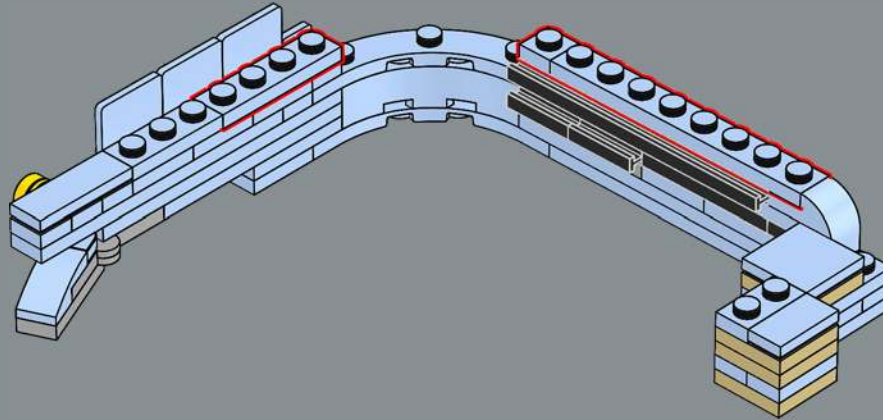

168

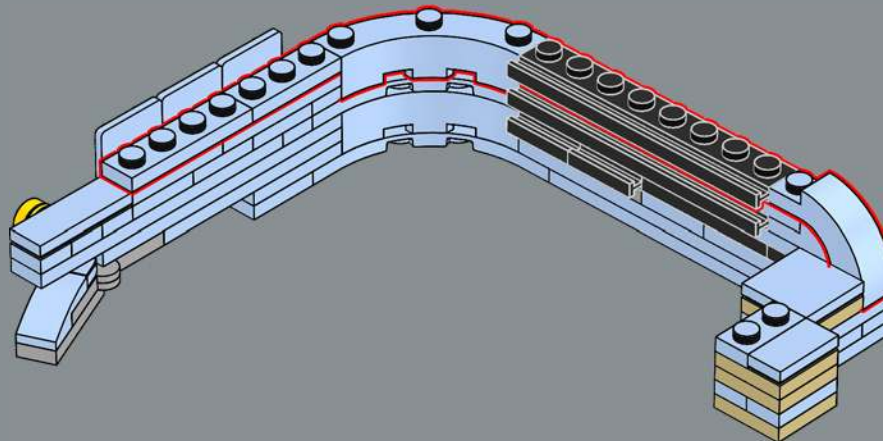

171

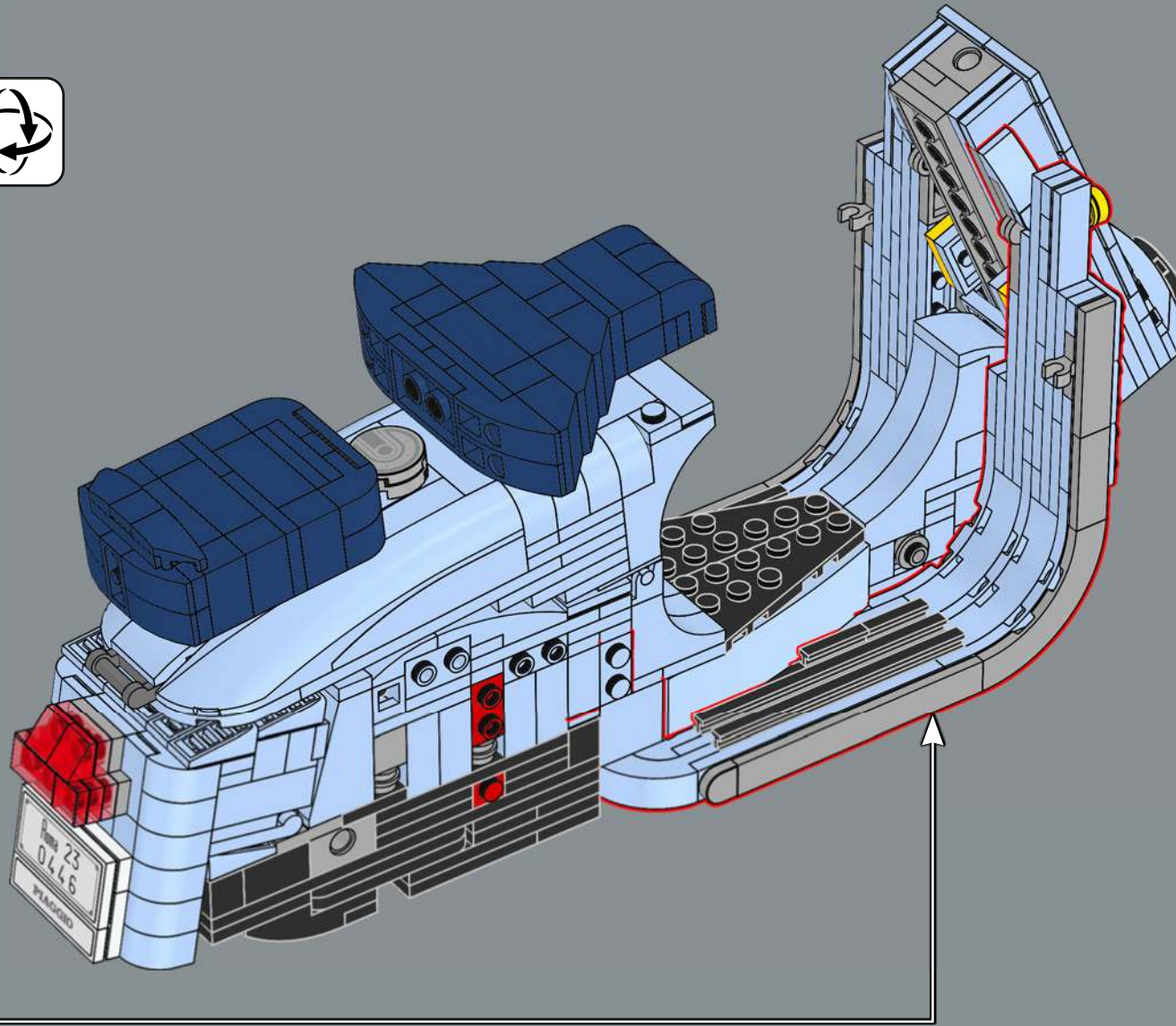

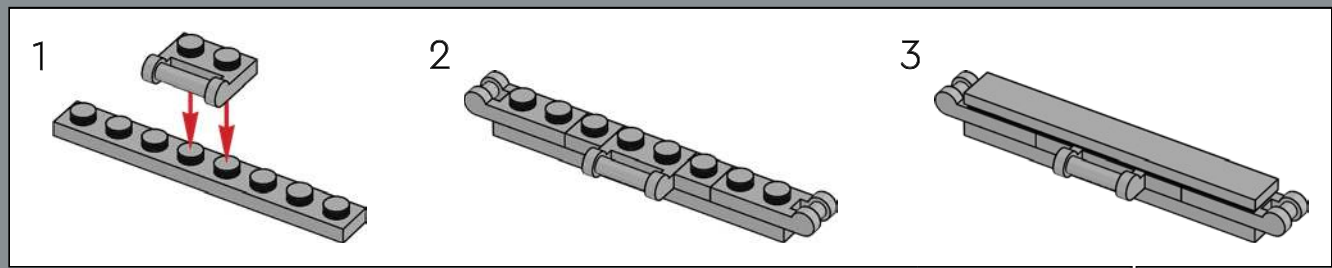
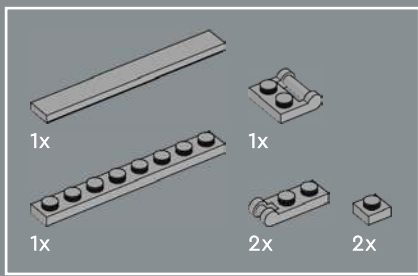

172

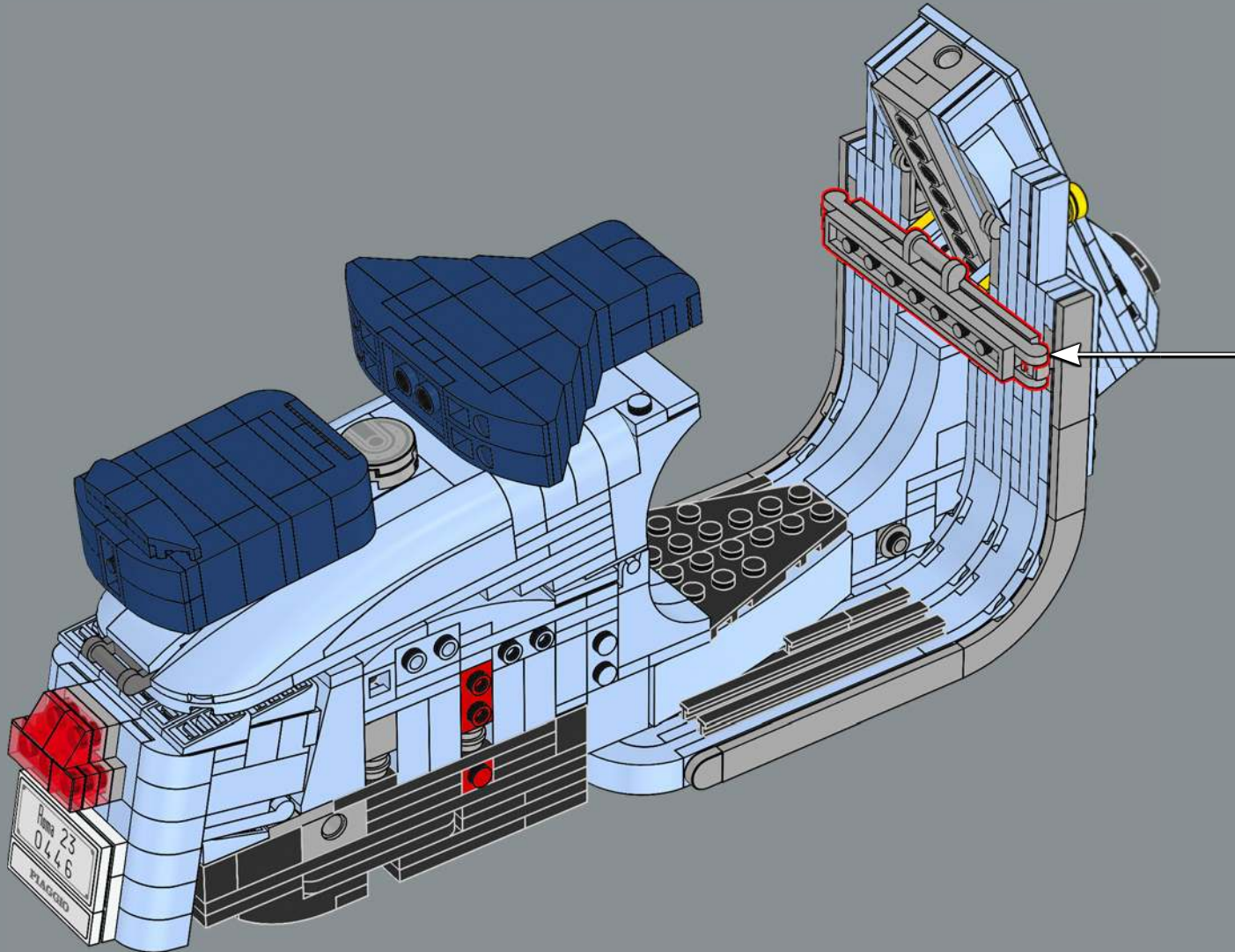

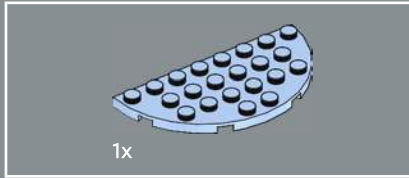
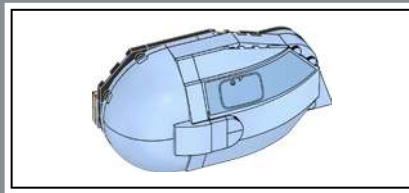
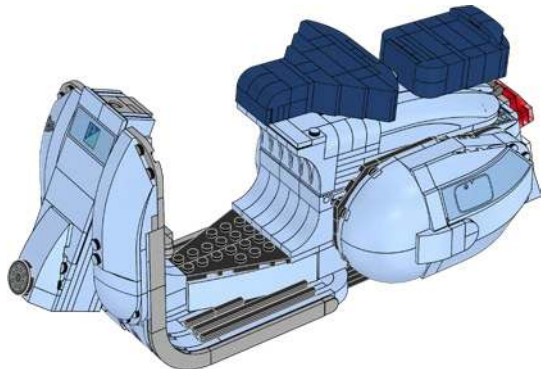
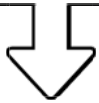

173

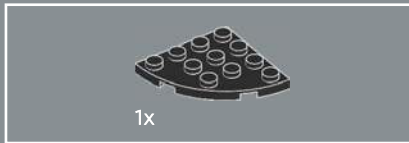
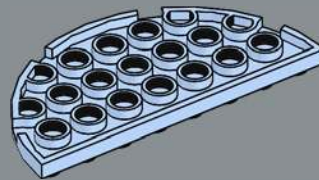

174

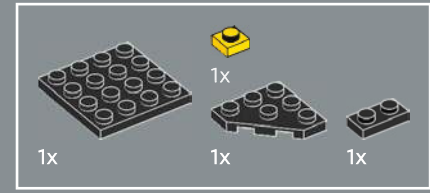
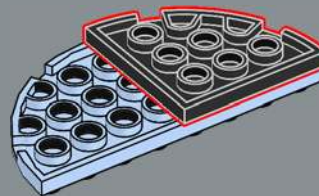

175

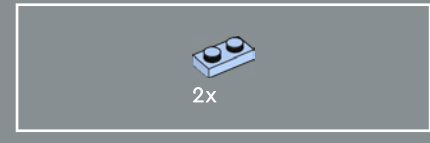
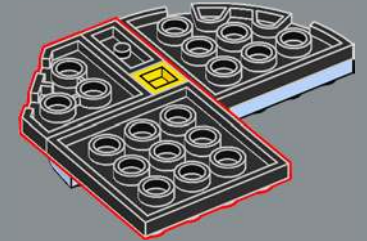

176

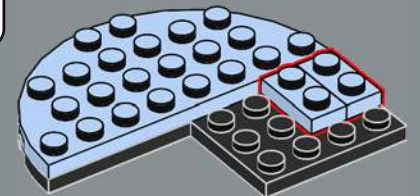

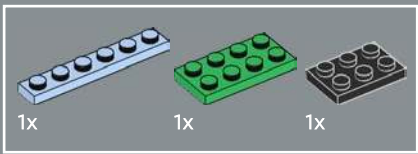

177

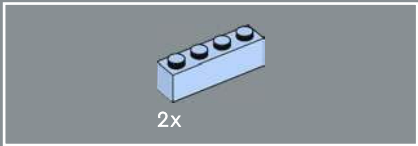
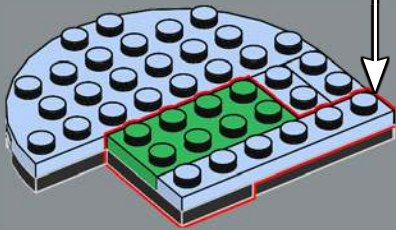
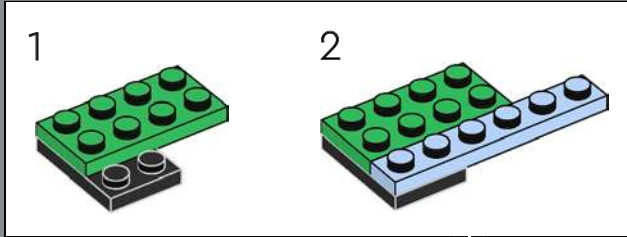

178

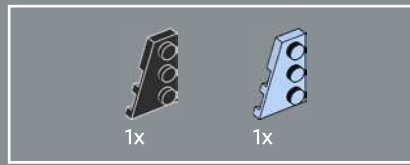
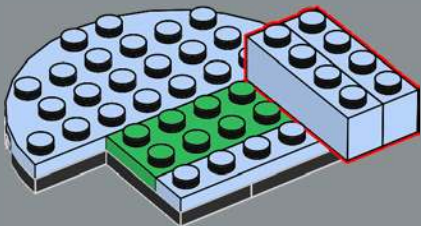

179

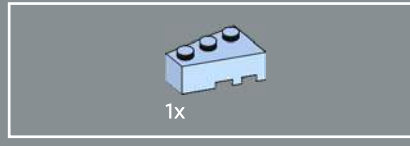
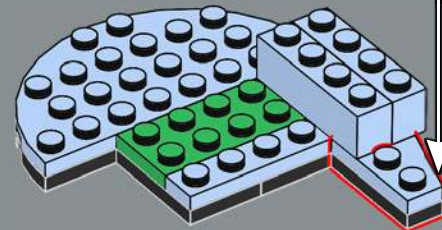
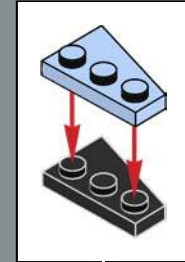

180

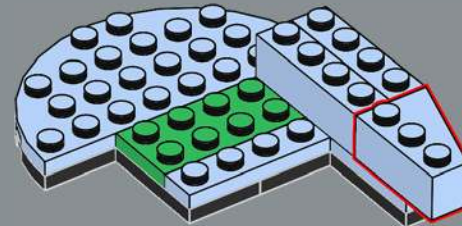

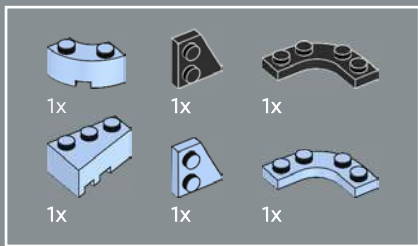

181

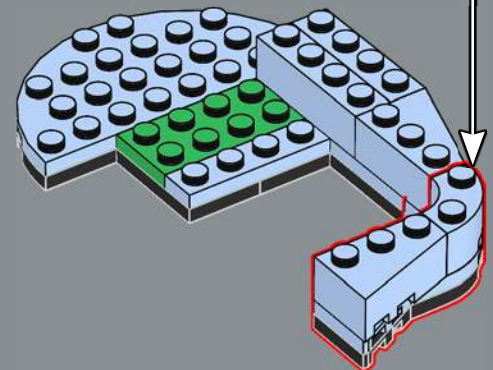
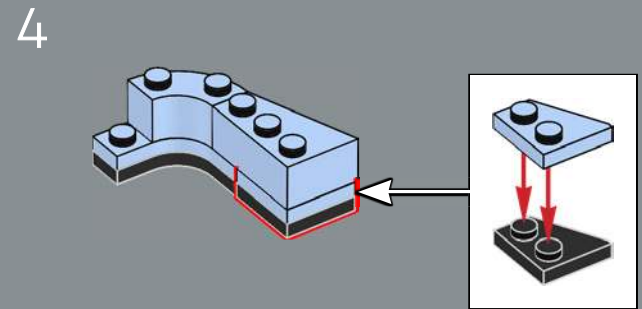
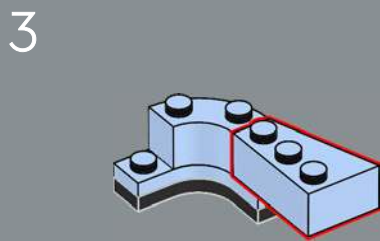
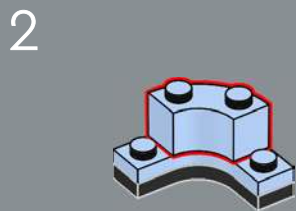
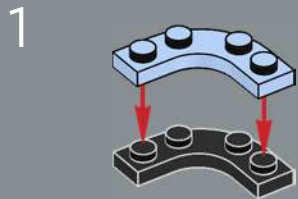

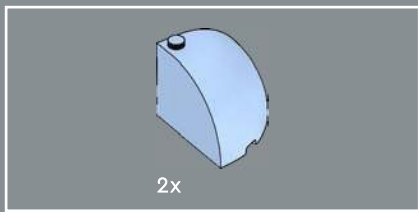

182

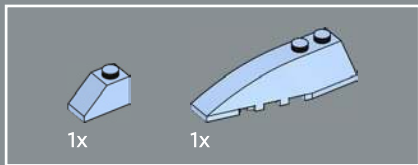
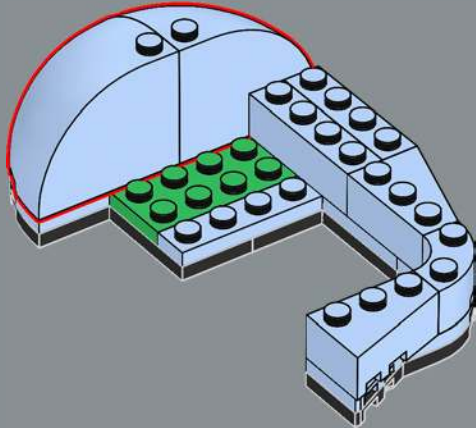

183

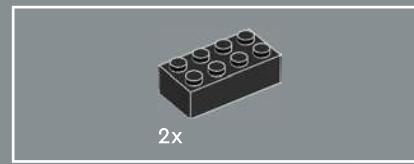
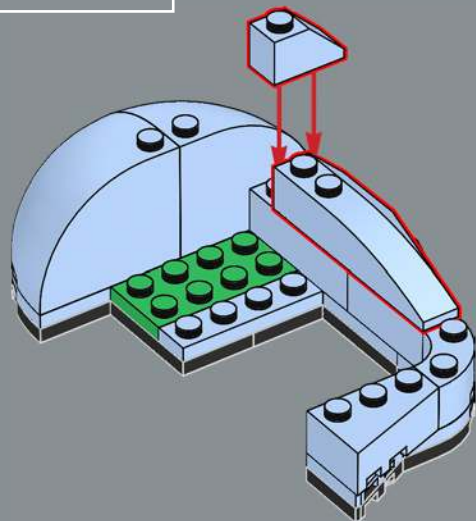

184

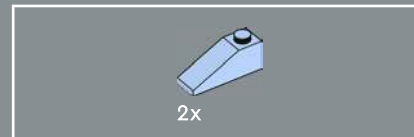
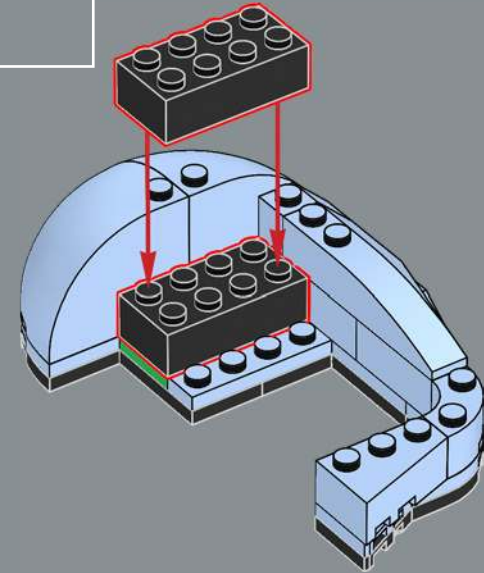

185

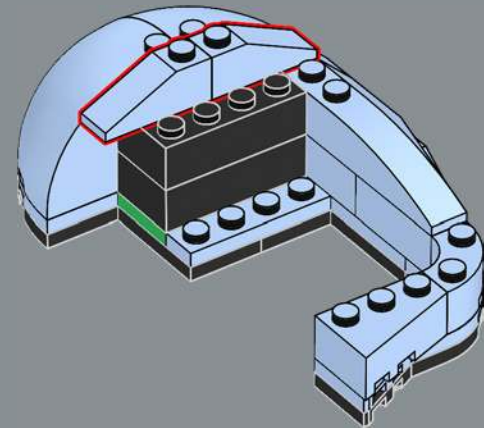

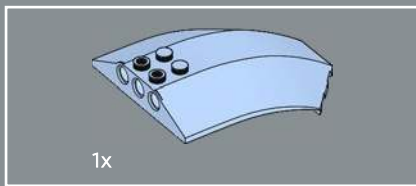

186

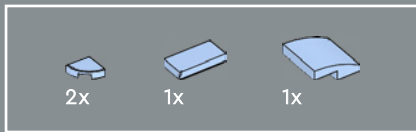
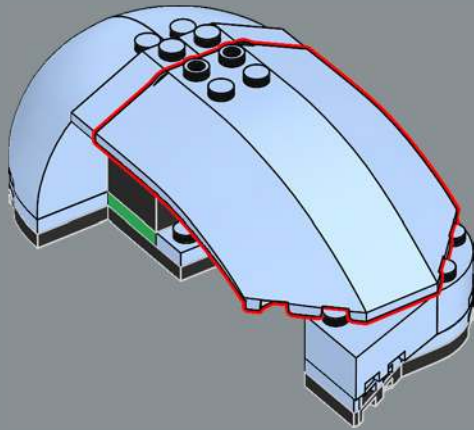

187

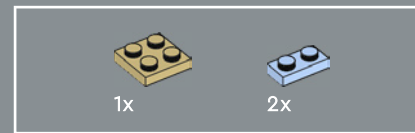
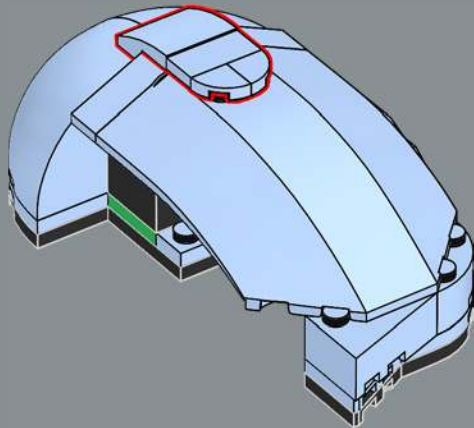

188

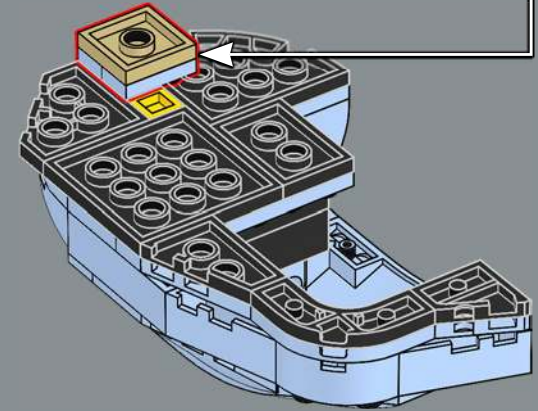
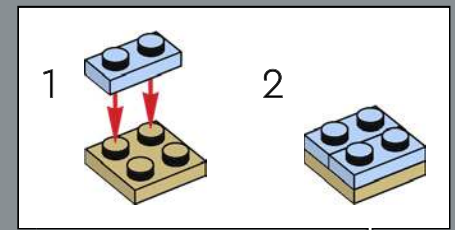

189

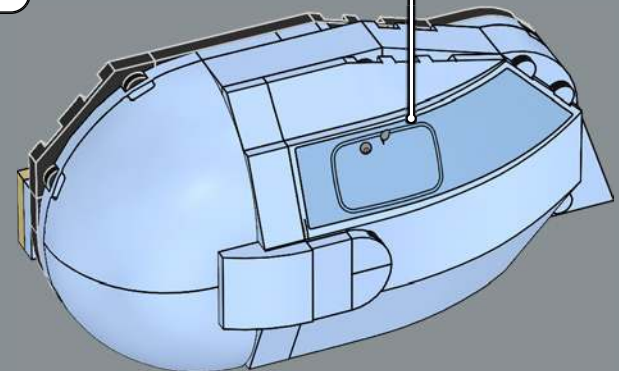



190

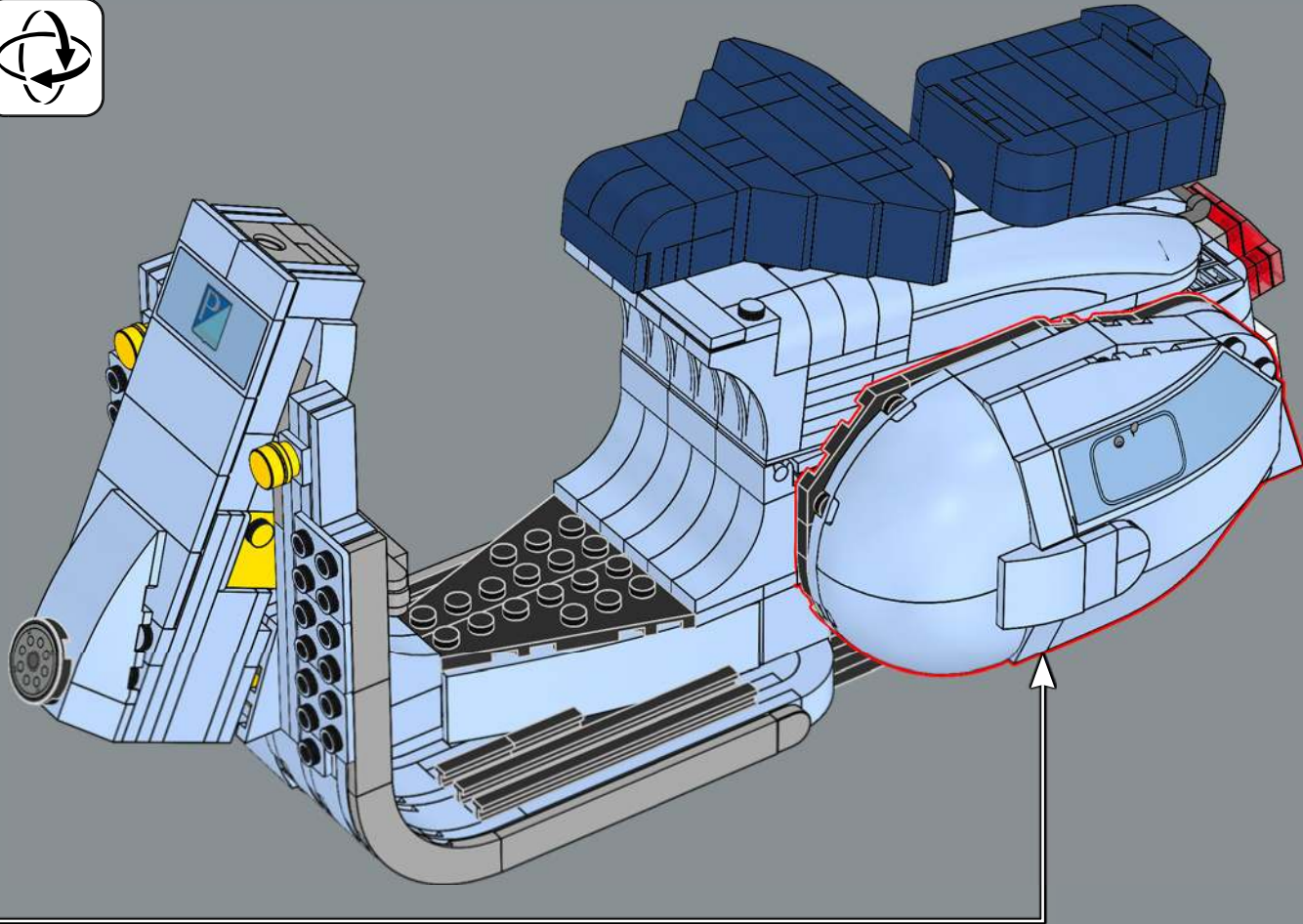

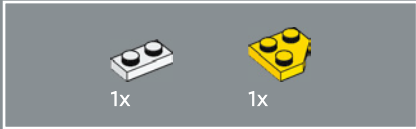
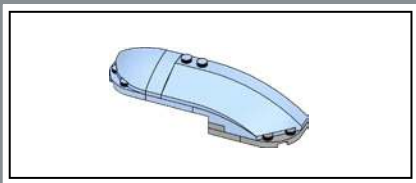

191

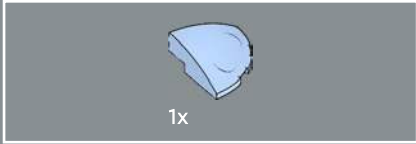

192

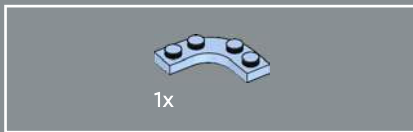

193

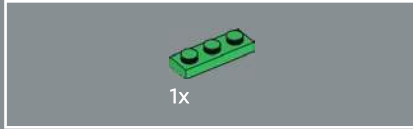

194

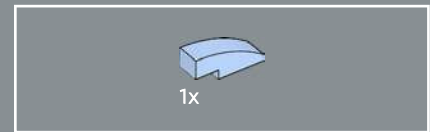
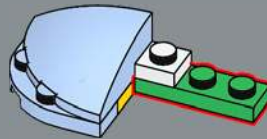

195

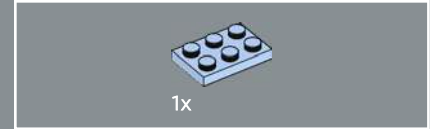
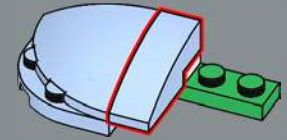

196

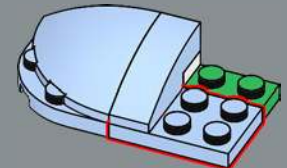

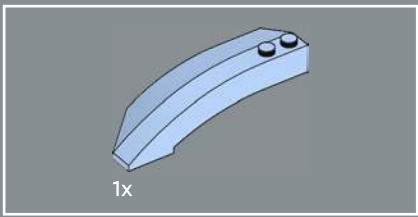

197

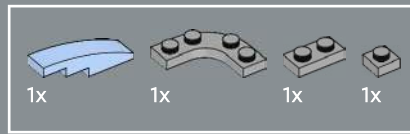
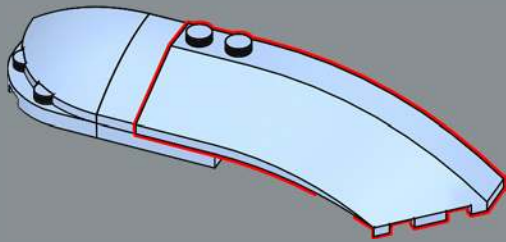

198

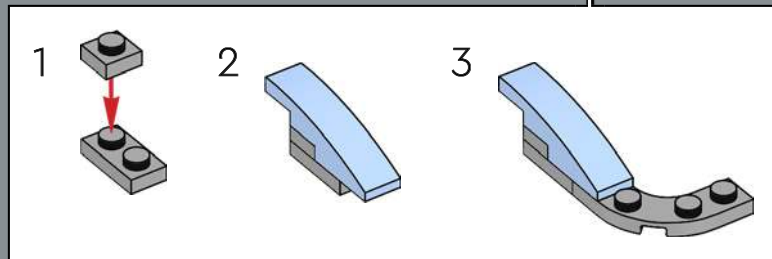
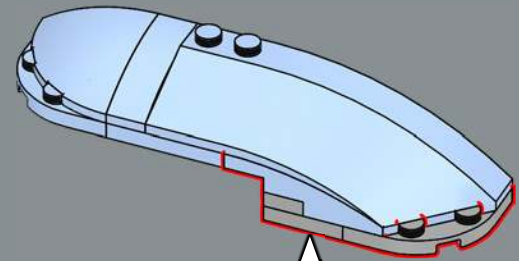

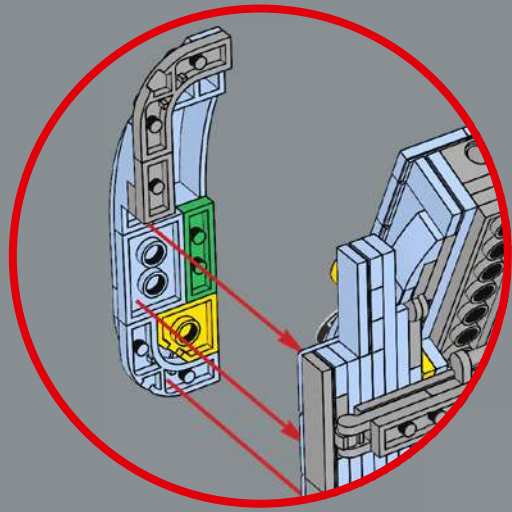

199

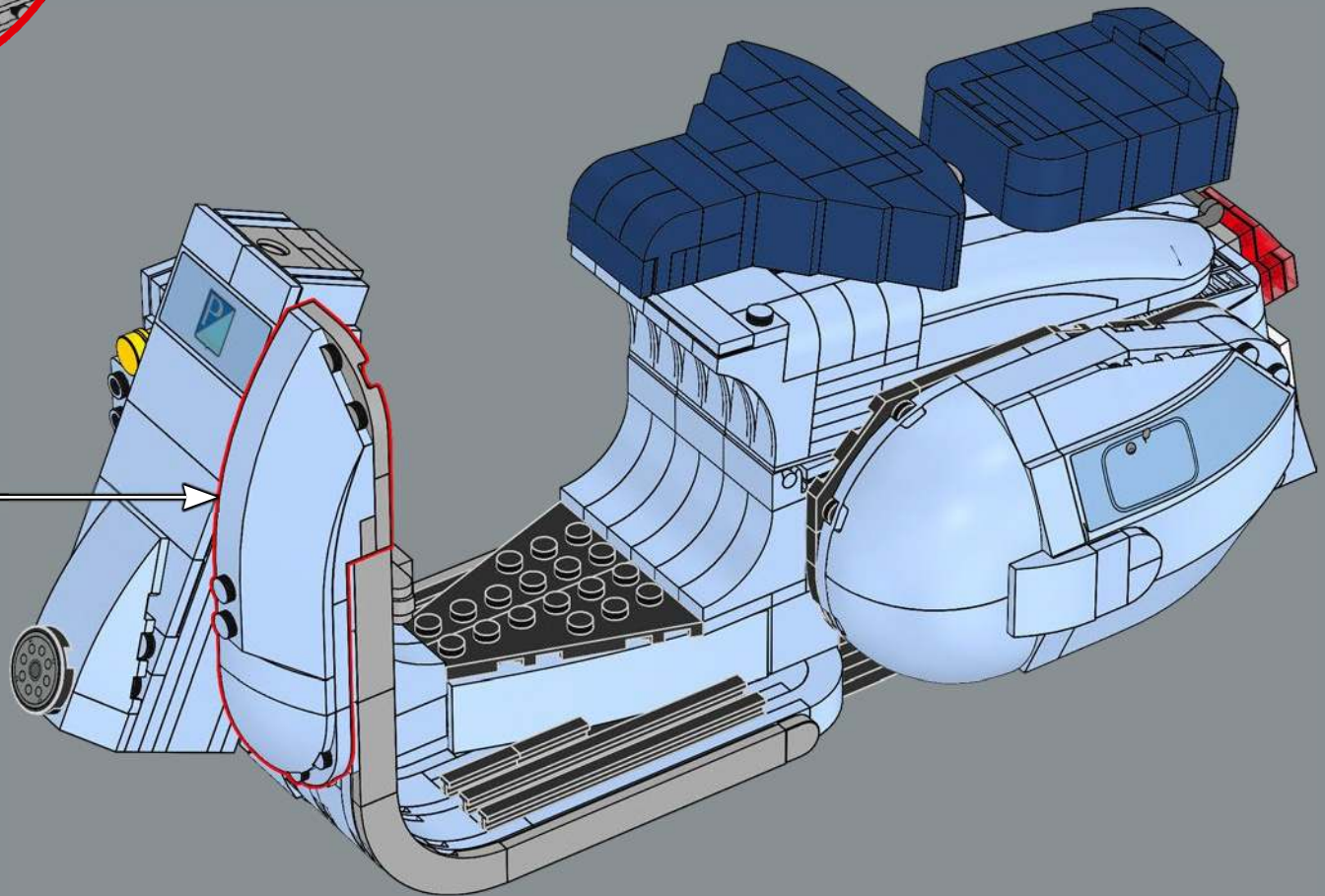

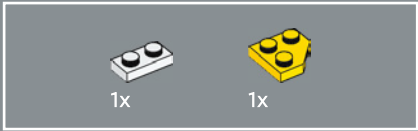
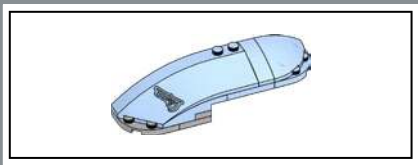

200

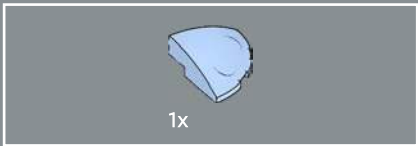

201

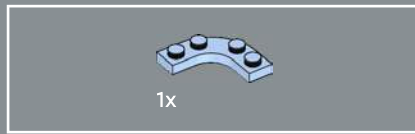

202

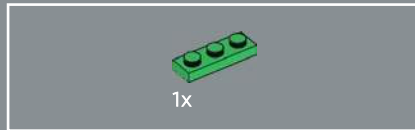

203

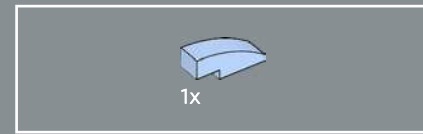
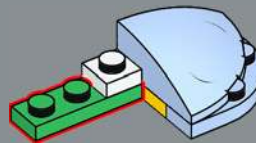

204

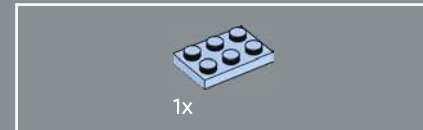
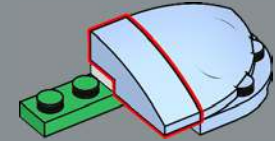

205

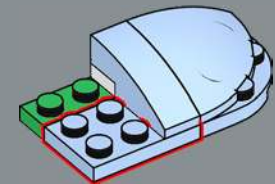

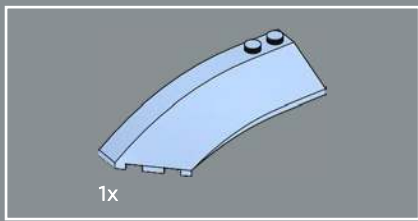

206

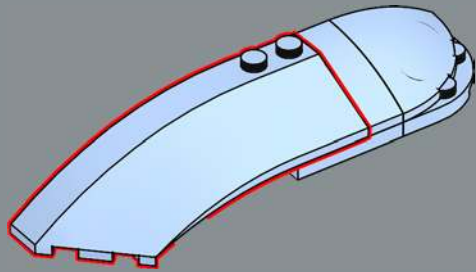

207

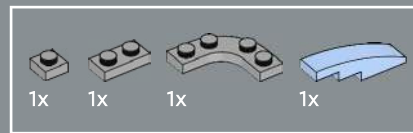
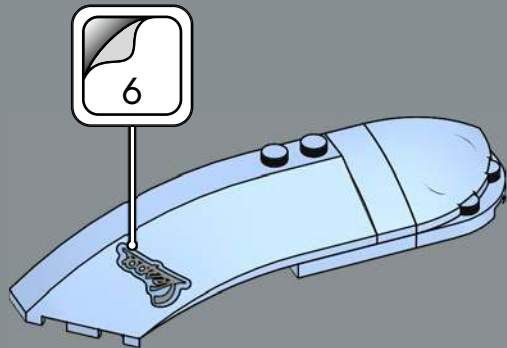

208

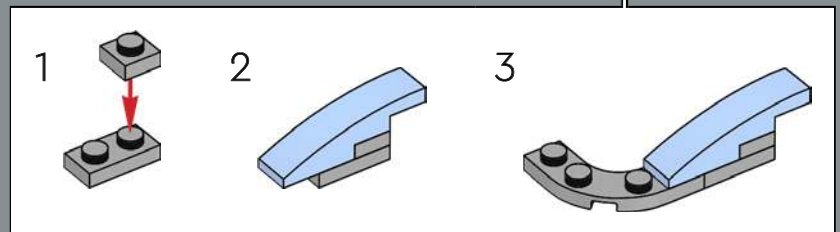
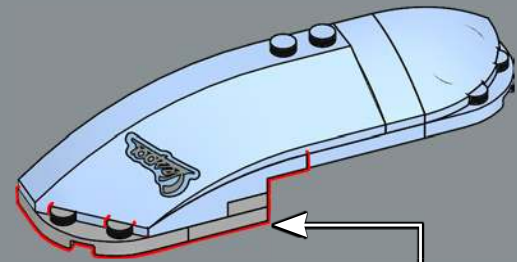

209

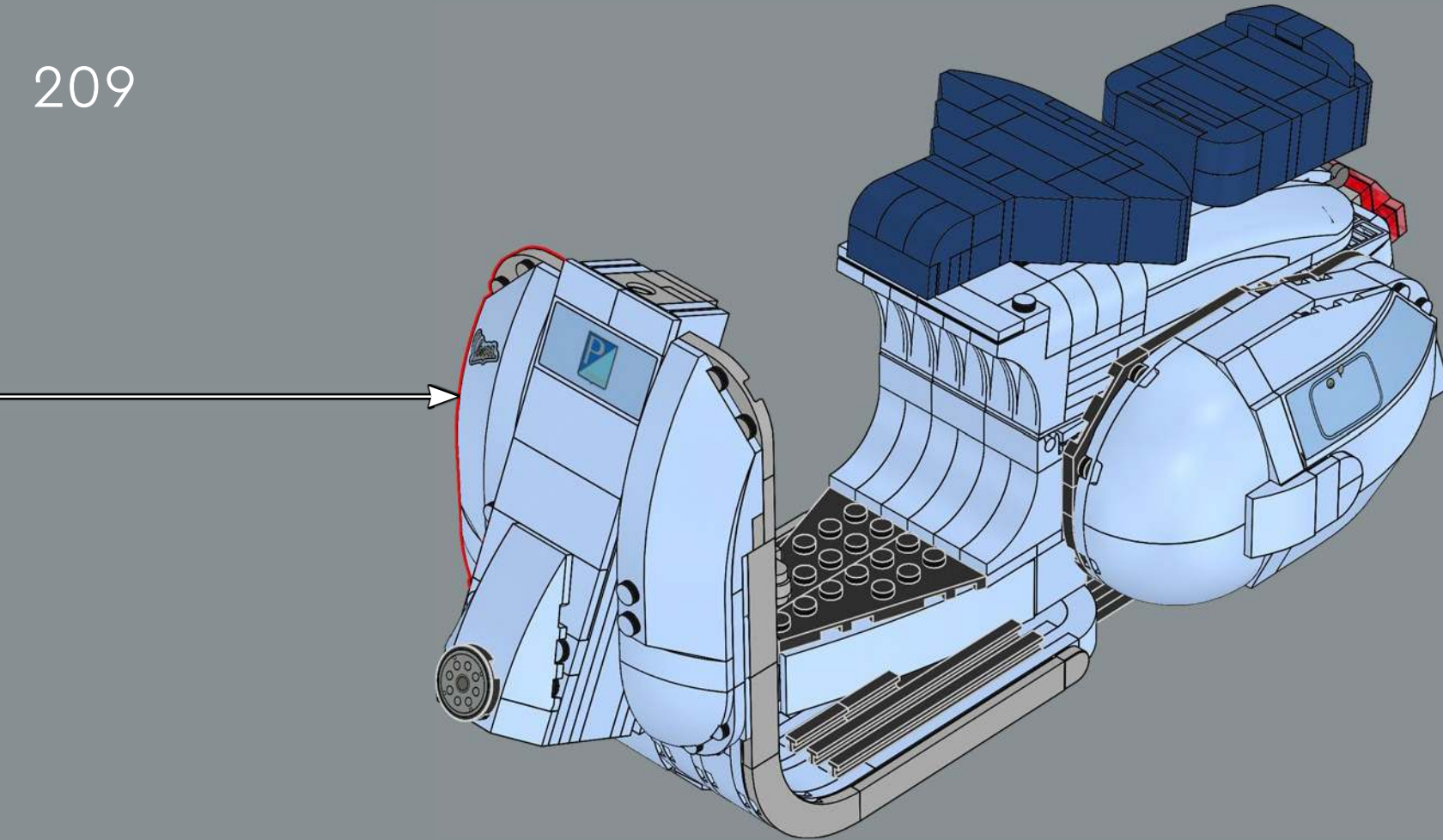

Piaggio has produced over 150 models of the original Vespa, adapting it to changing needs and fashions.

Piaggio ha prodotto oltre 150 modelli di Vespa, adattandola alle mutevoli esigenze e mode.

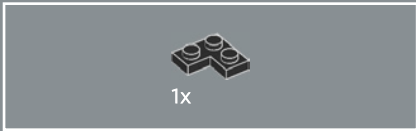
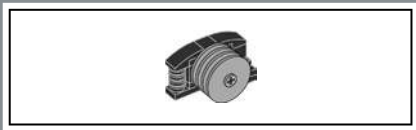

210

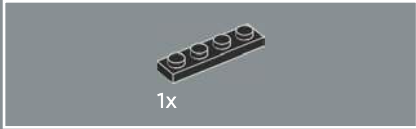

211

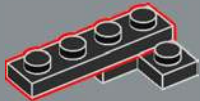

212

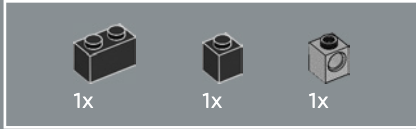
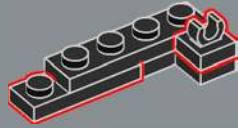

213

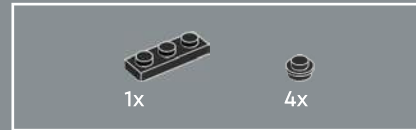
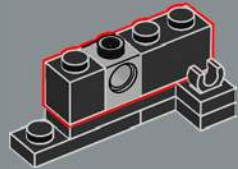

214

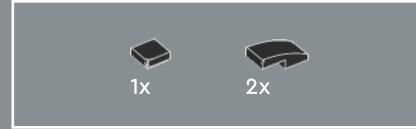
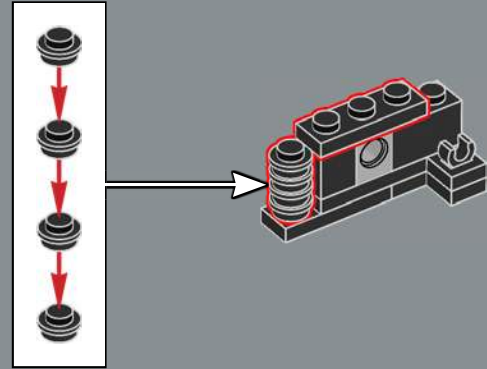

215

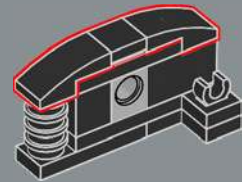

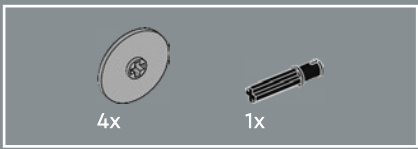

216

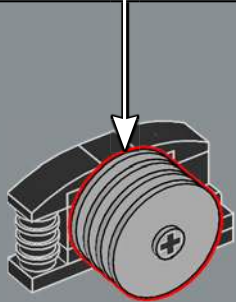
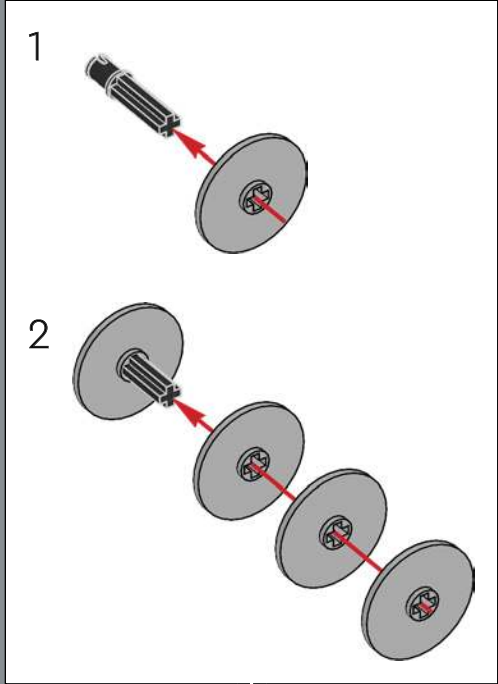

217

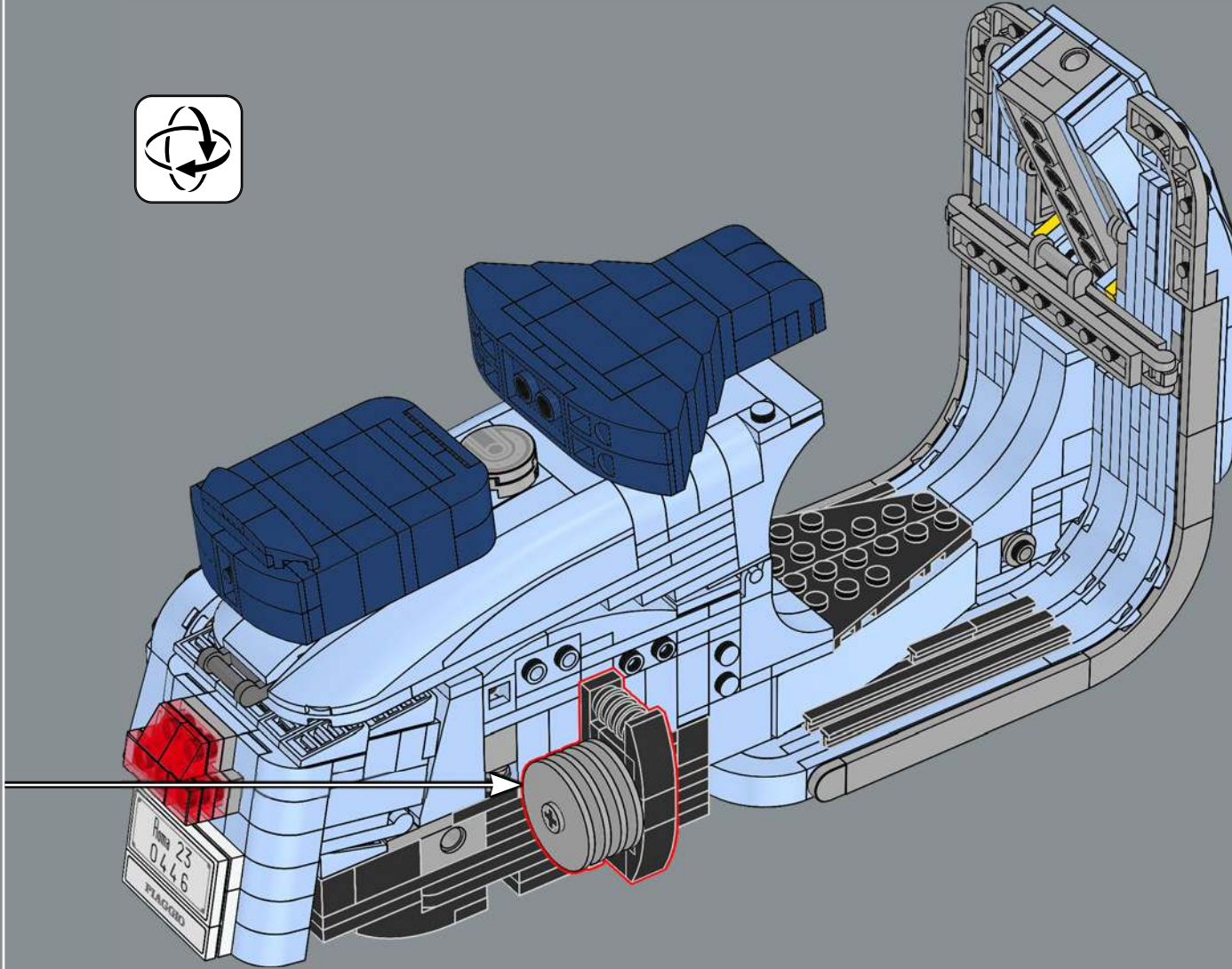

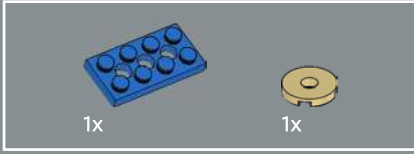
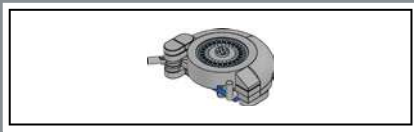

218

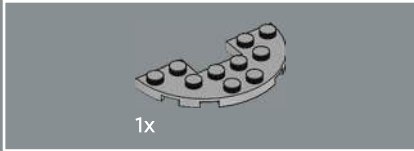
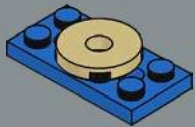

219

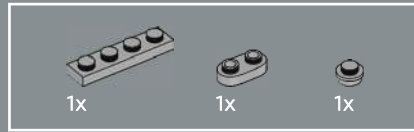
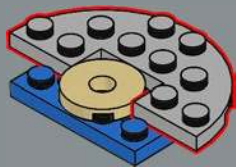

220

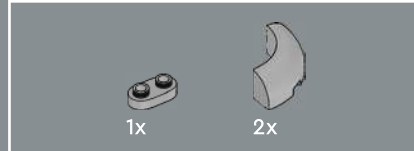
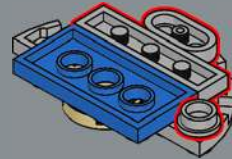

221

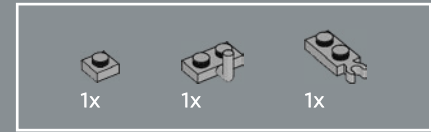
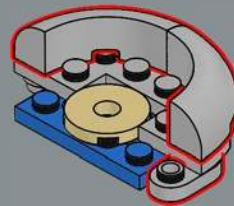

222

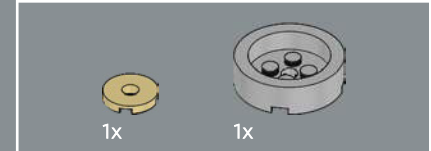
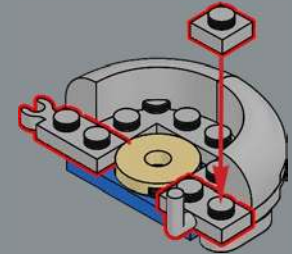

223

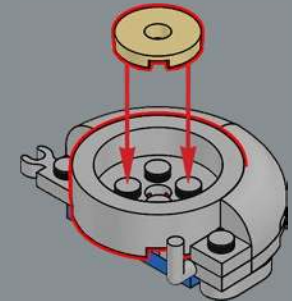

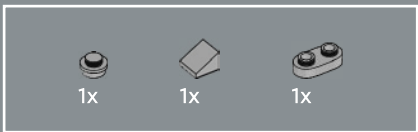

224

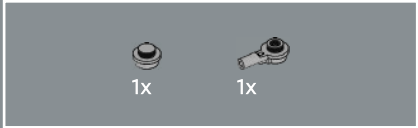
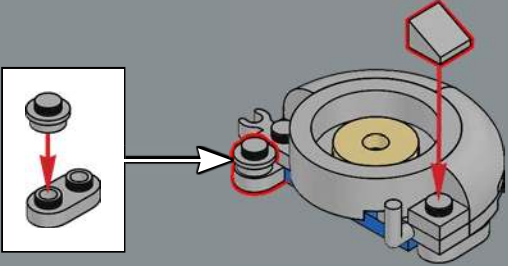

225

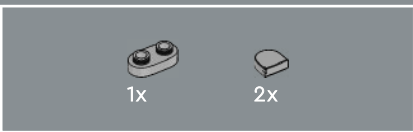
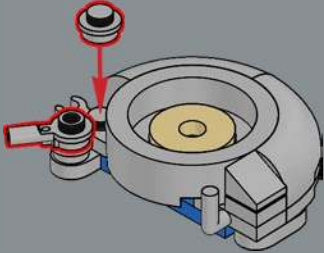

226

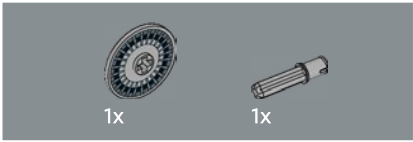
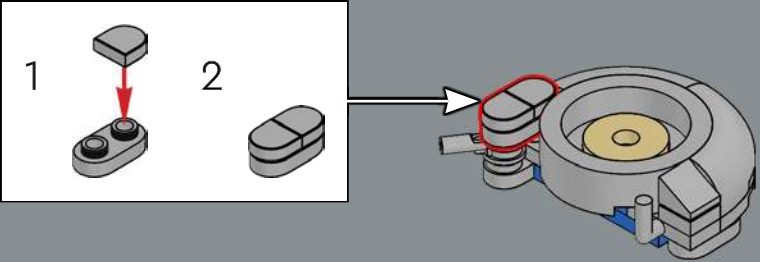

227

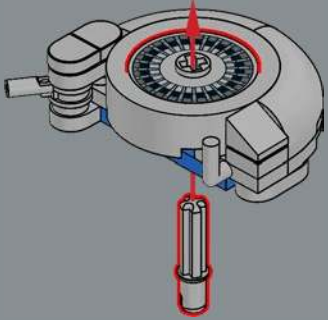

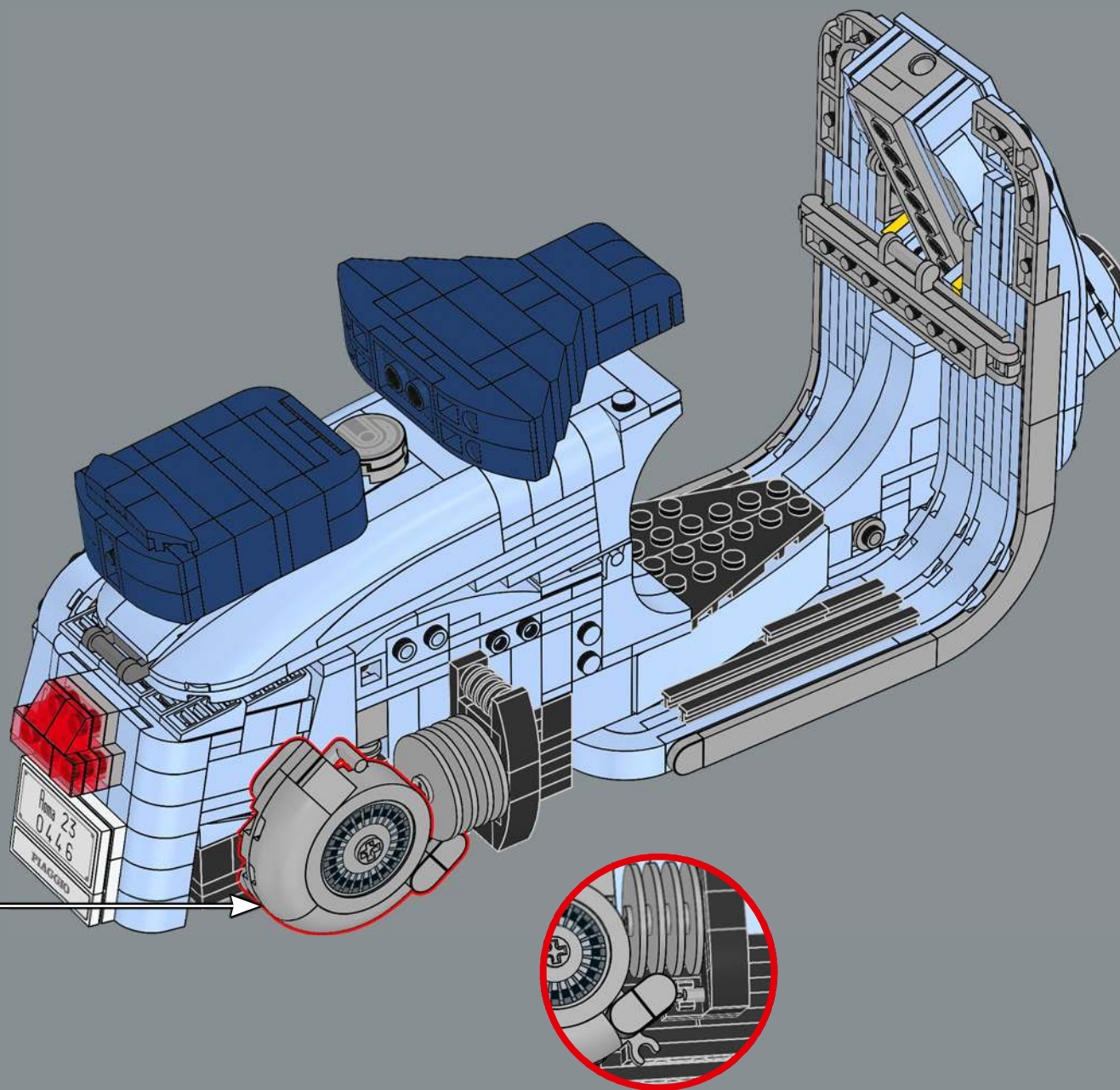

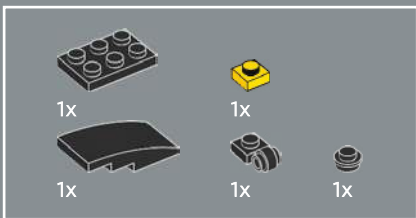

229

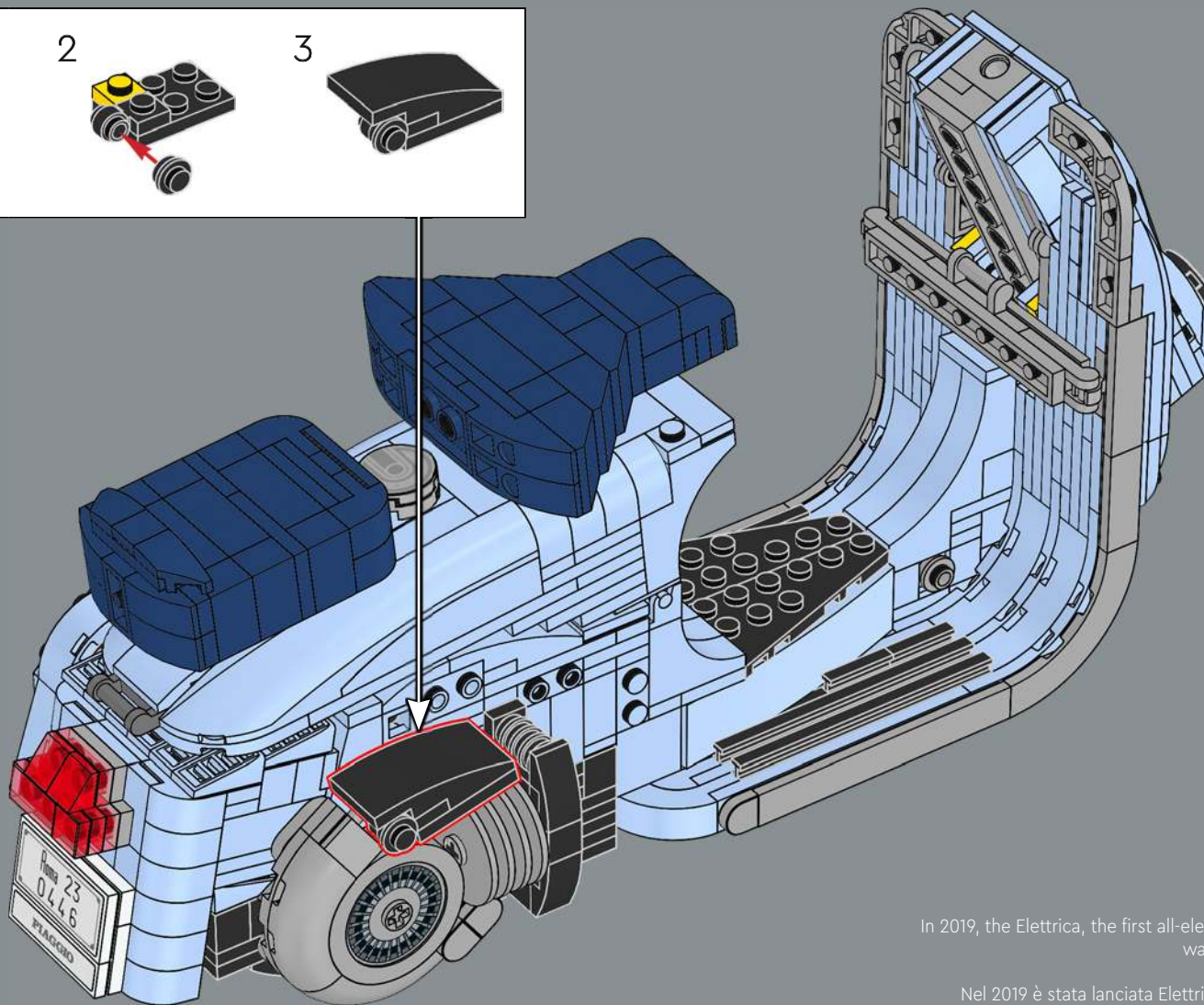
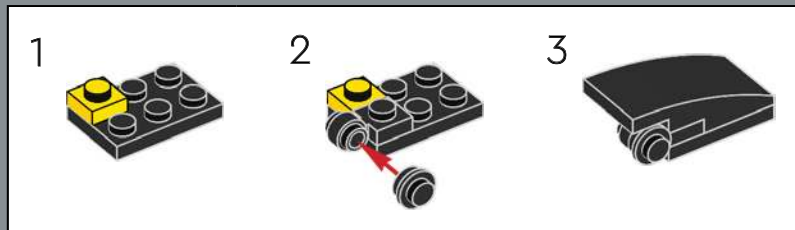

In 2019, the Elettrica, the first all-electric Vespa, was launched.

Nel 2019 è stata lanciata Elettrica, la prima Vespa completamente elettrica.

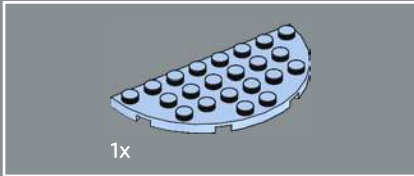
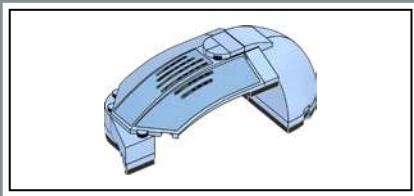

230

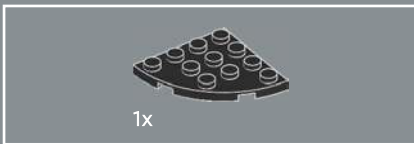
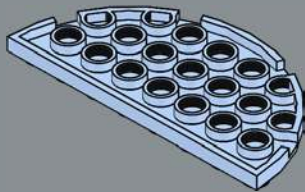

231

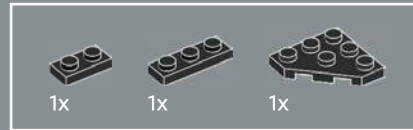
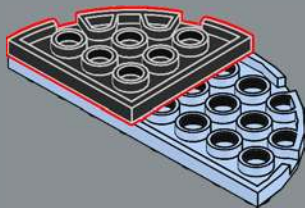

232

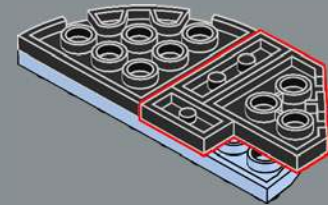

233

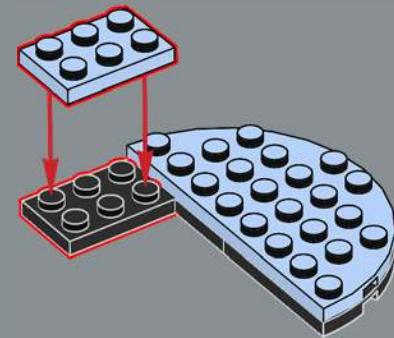

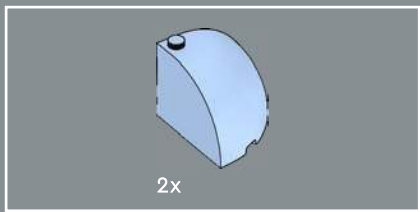

234

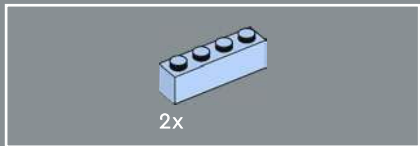
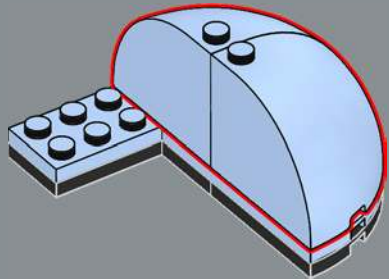

235

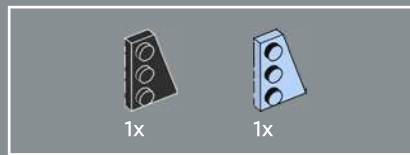
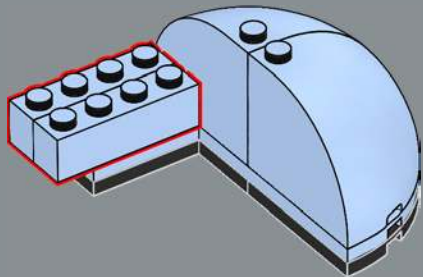

236

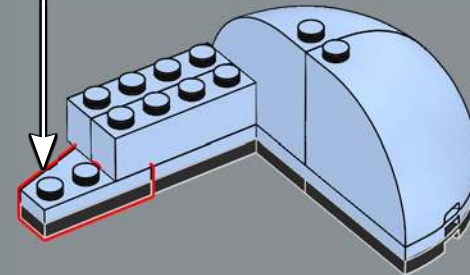
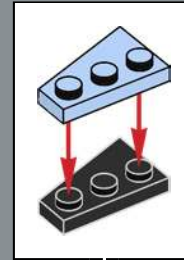

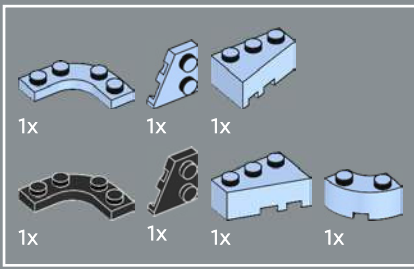

237

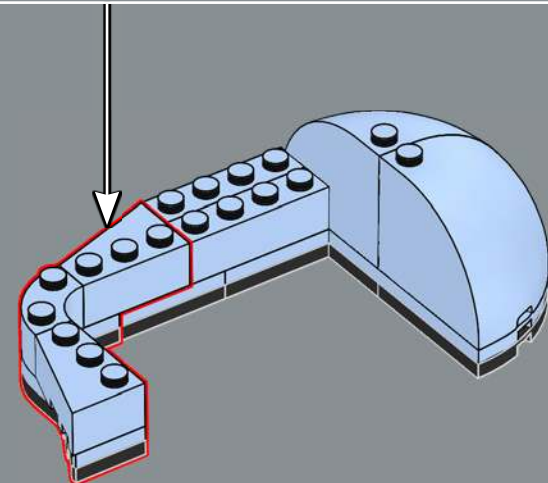
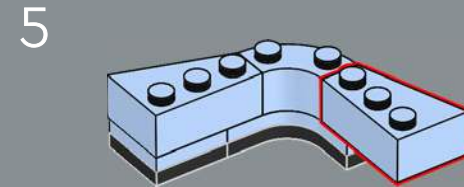
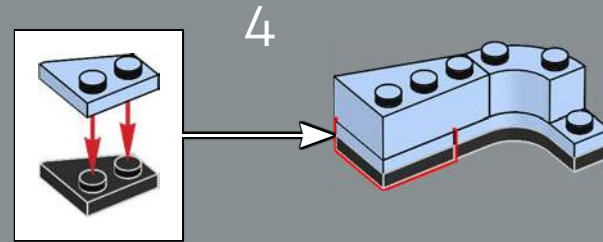
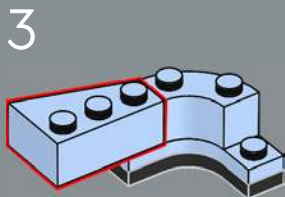
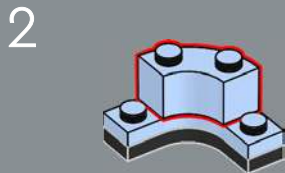
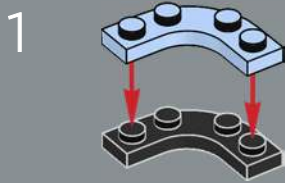

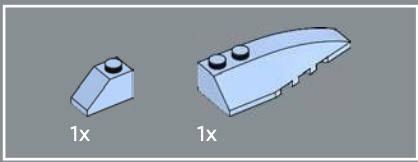

238

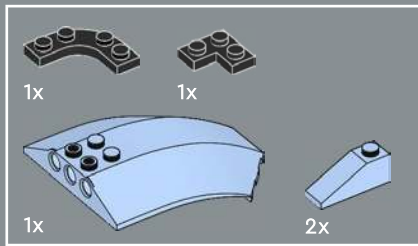
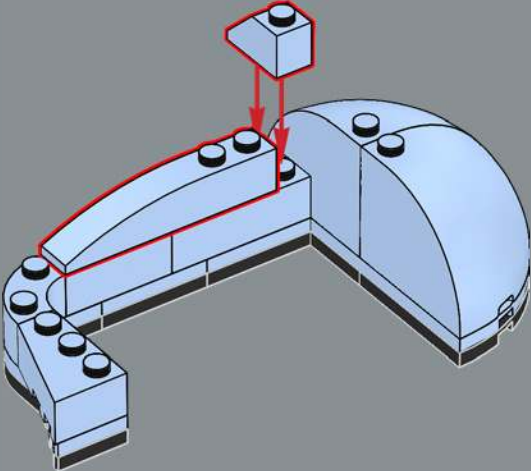

239

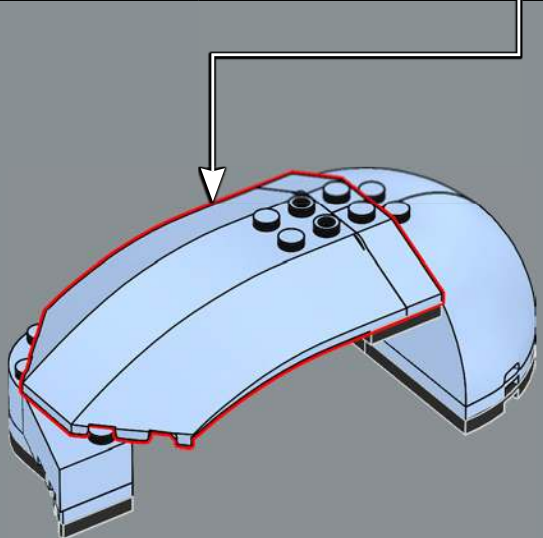
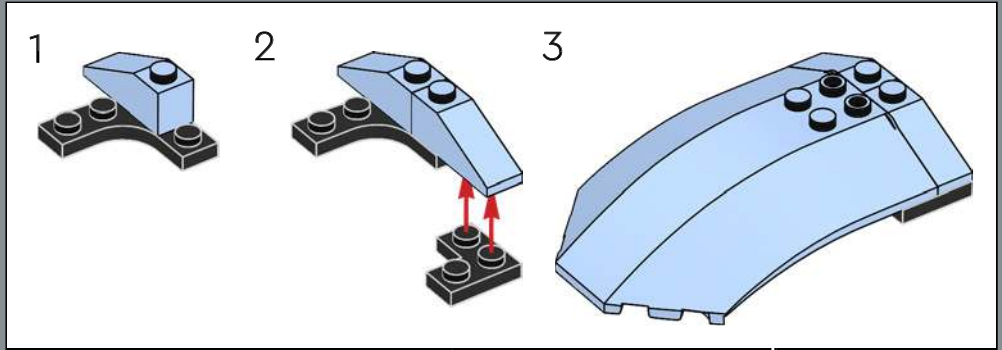

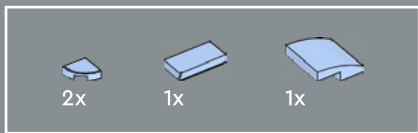

240

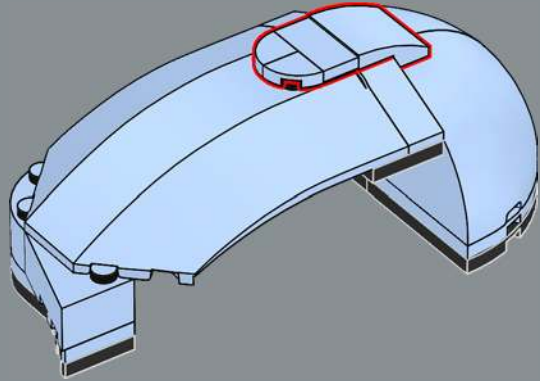

241

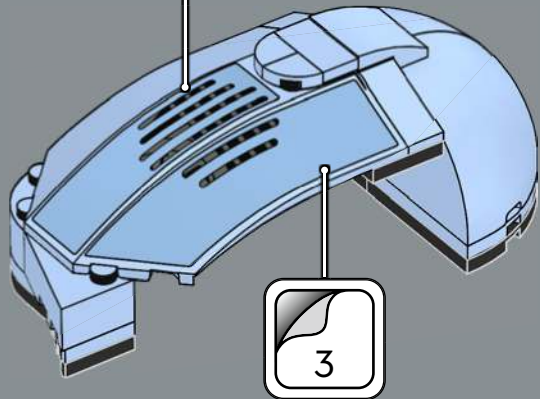

242

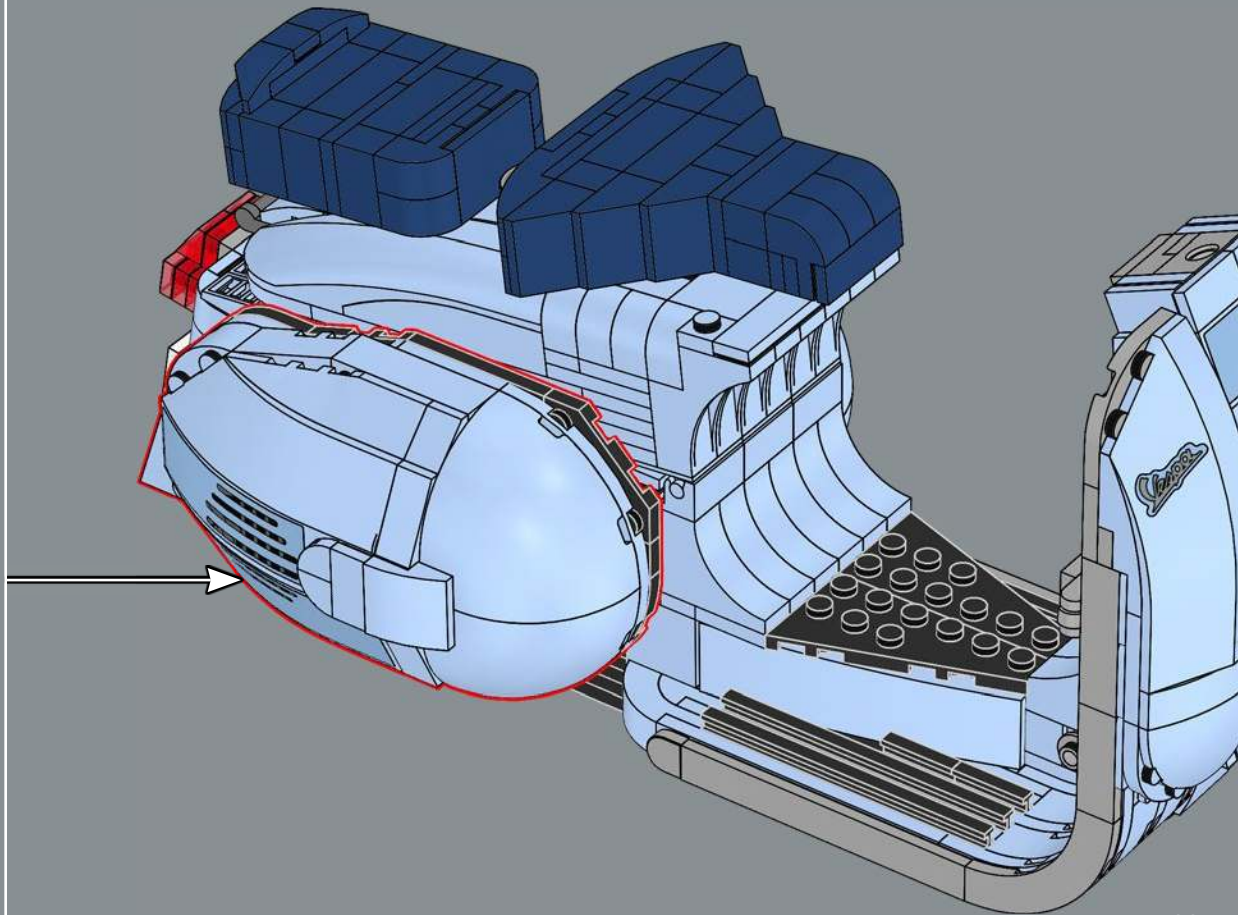

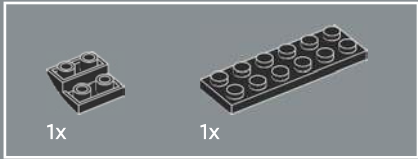
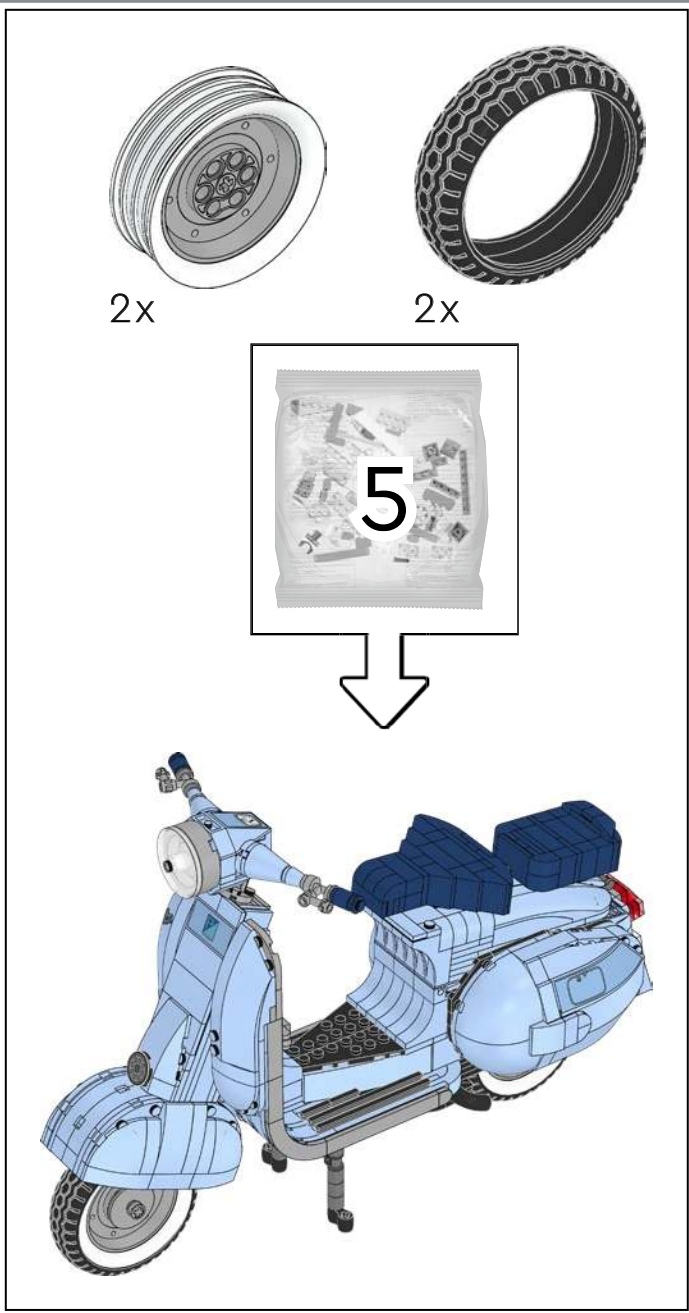

243

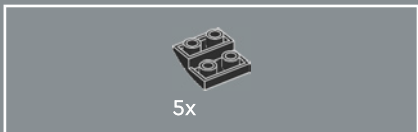
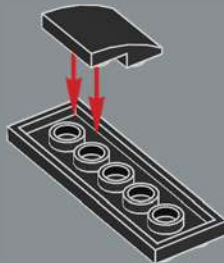

244

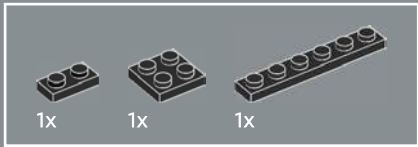
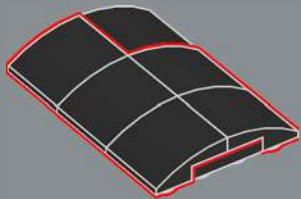

245

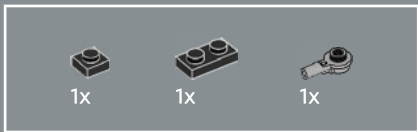
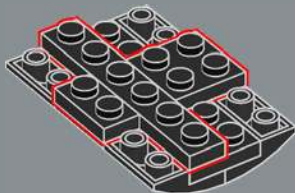

246

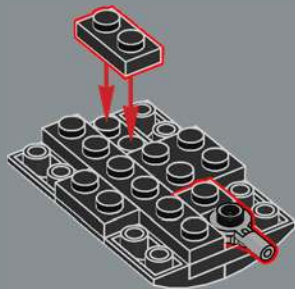

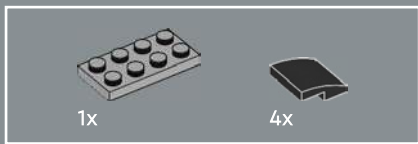

247

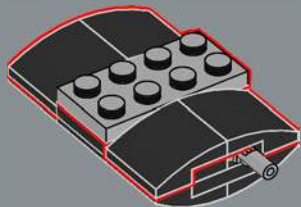

248

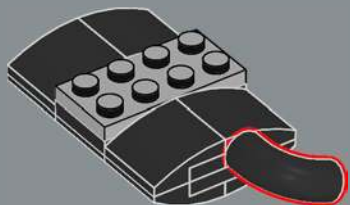

249

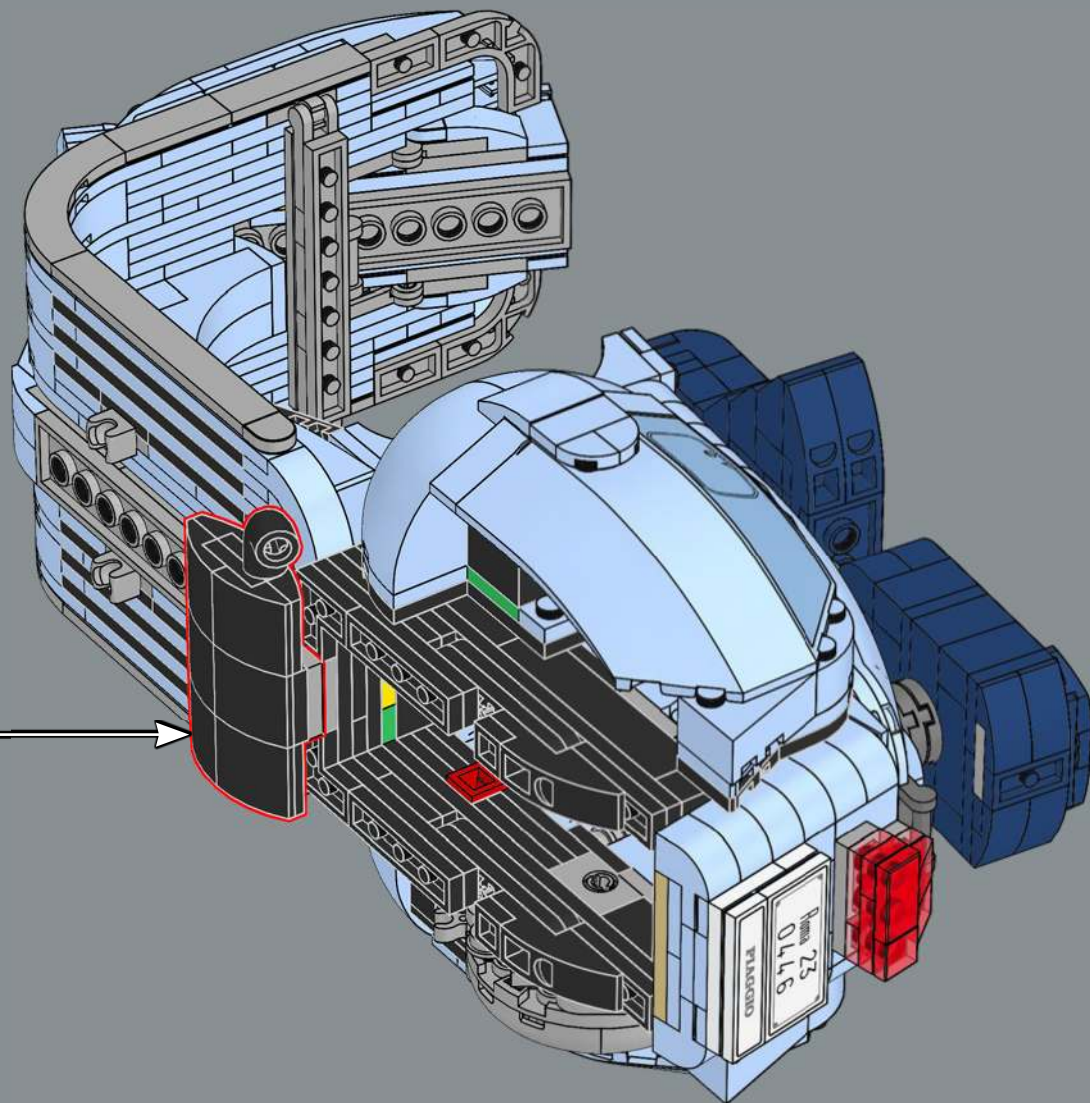

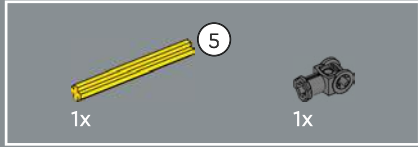
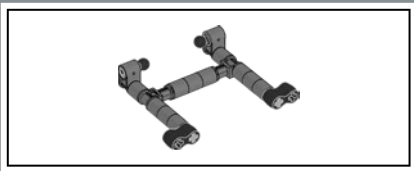

250

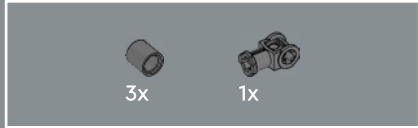
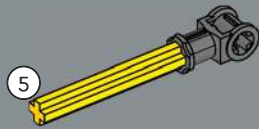

251

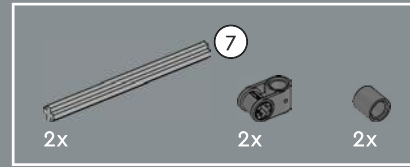
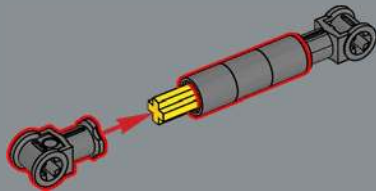

252

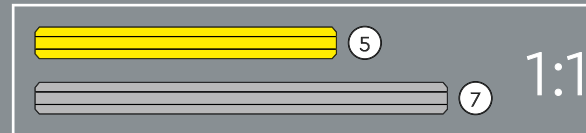
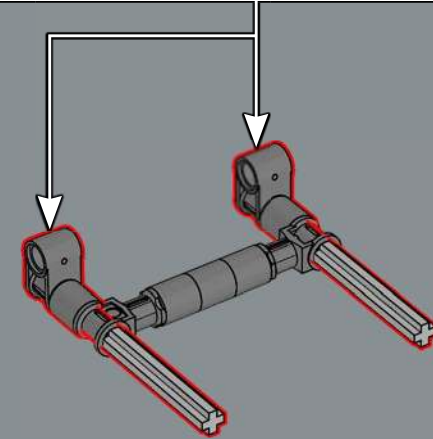
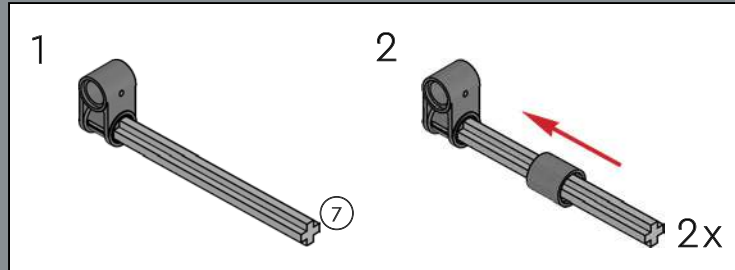



253

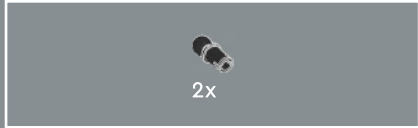
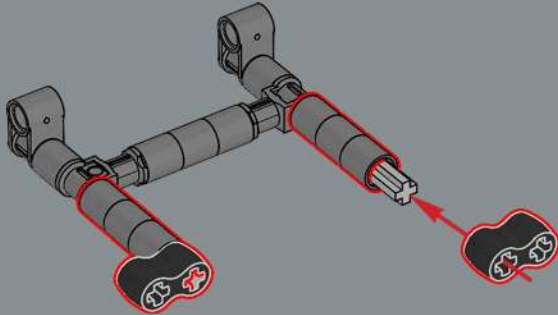

254

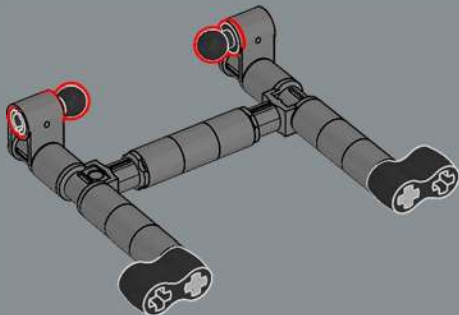

255

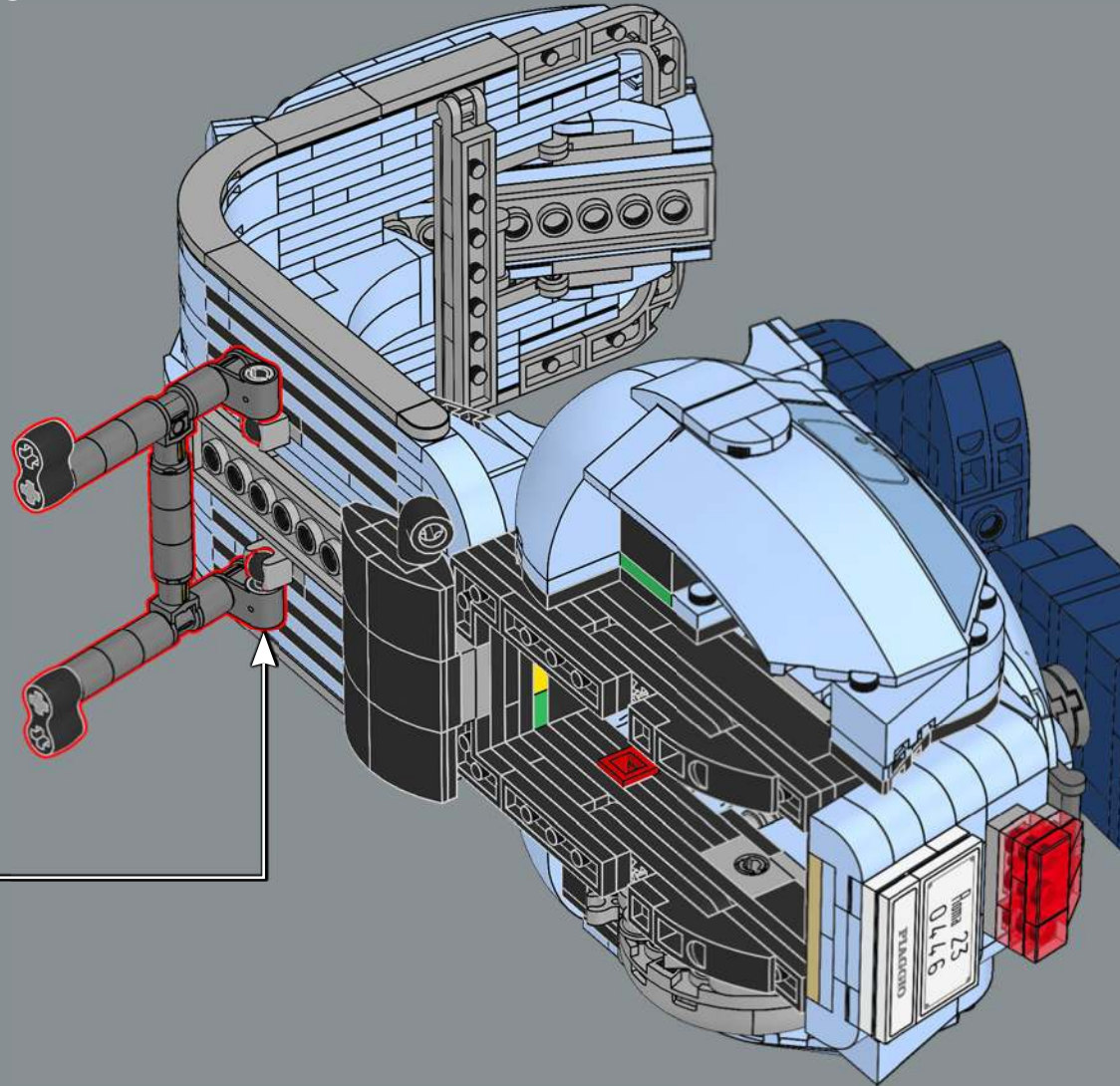

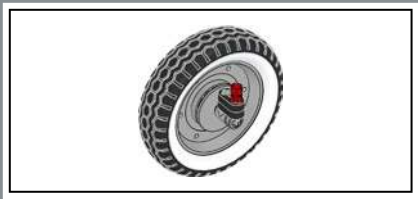

256

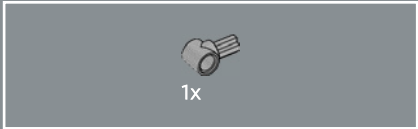

257

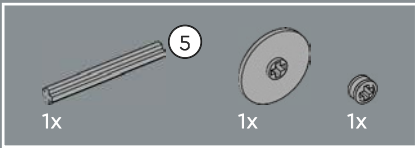

258

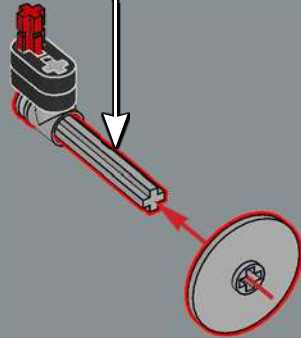
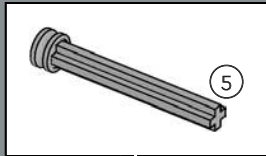

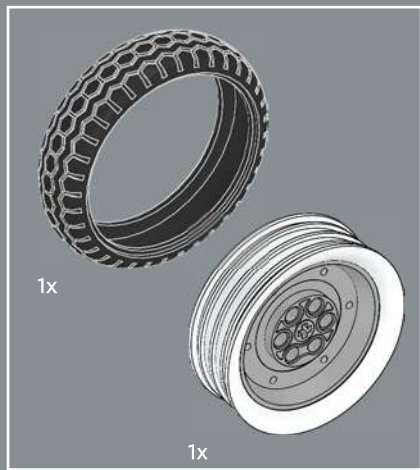

259

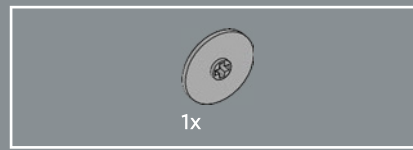
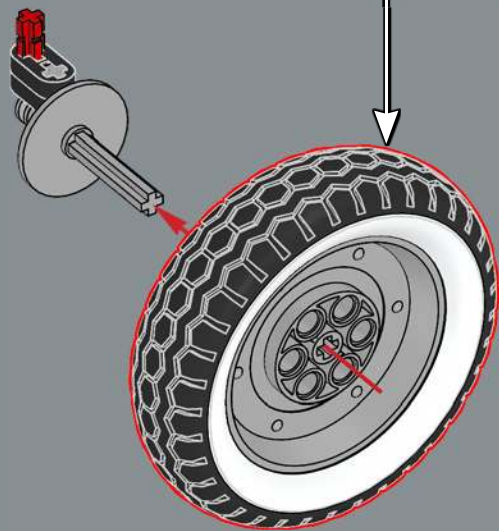
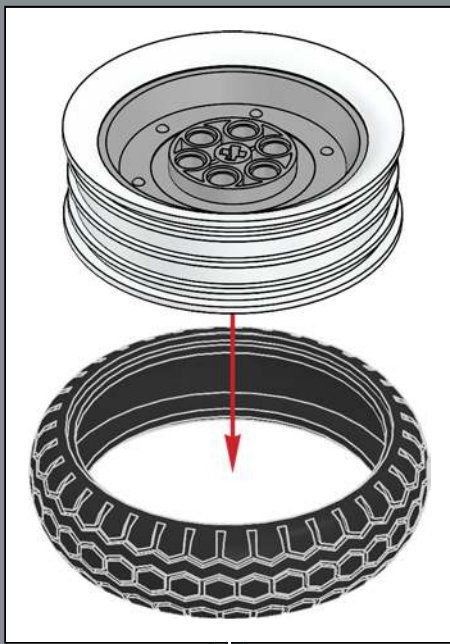

260

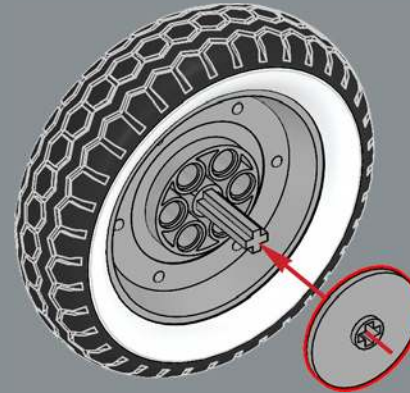

261

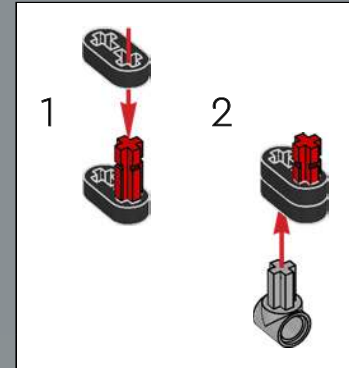
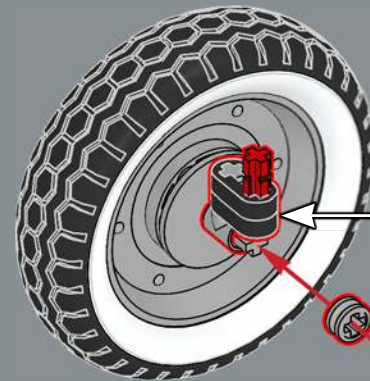

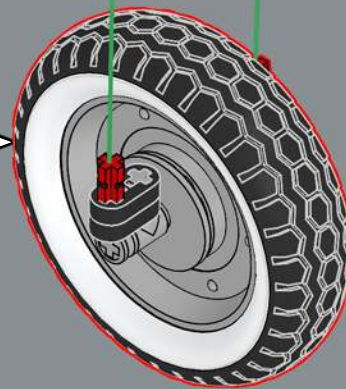
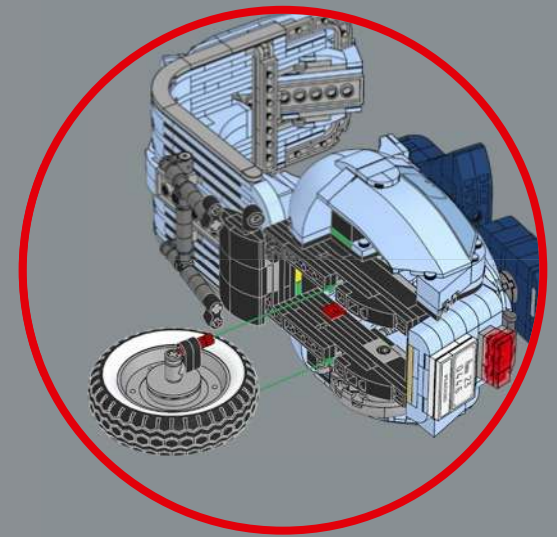
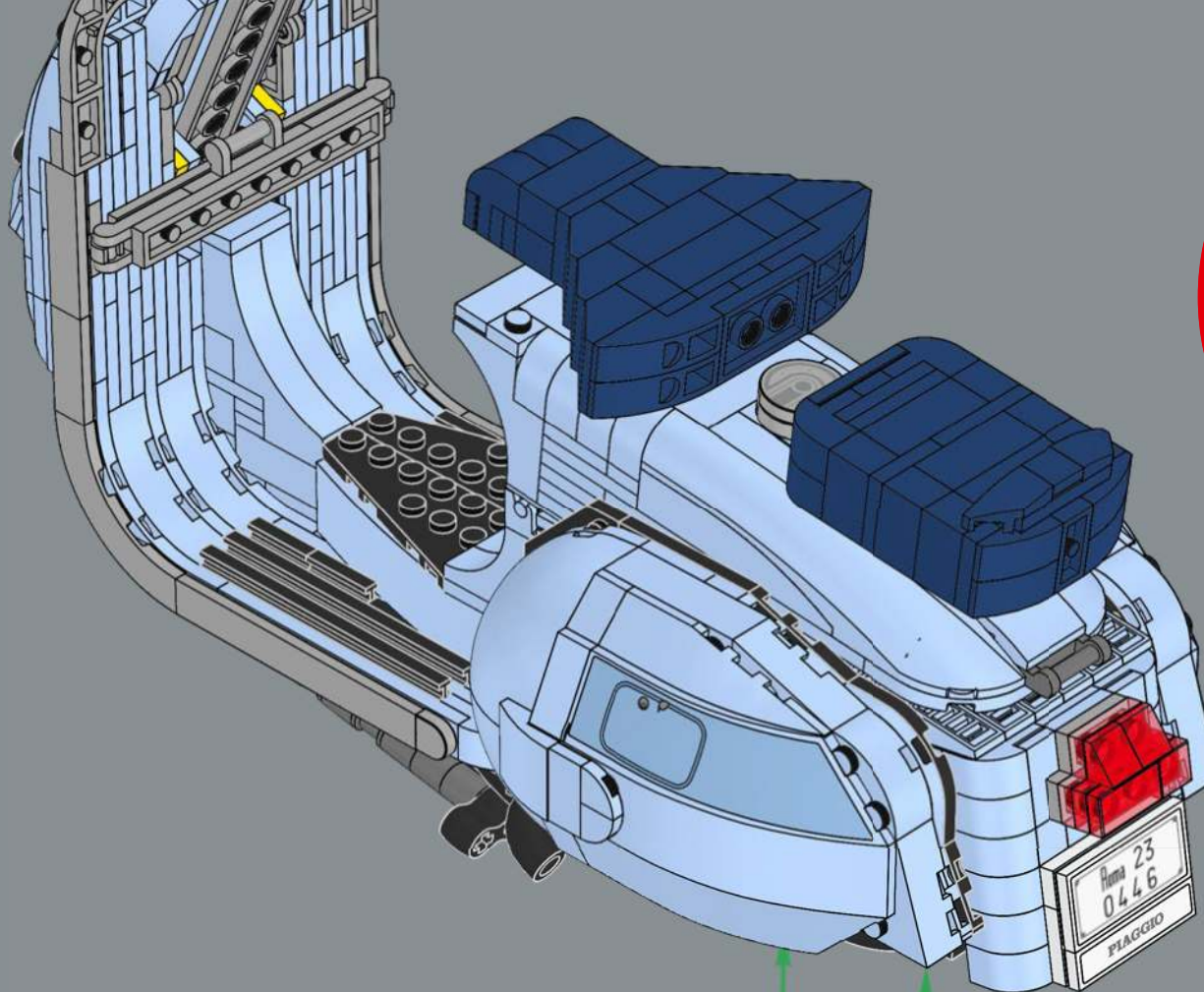

It's the first time in LEGO® history that we have a two-colour wheel with the white outer wall on the black tyre.

È la prima volta nella storia di LEGO® che viene realizzata una ruota a due colori, con pneumatico nero e fianco bianco.

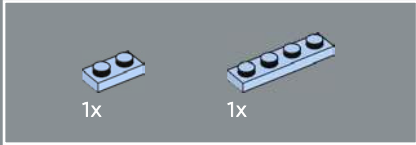
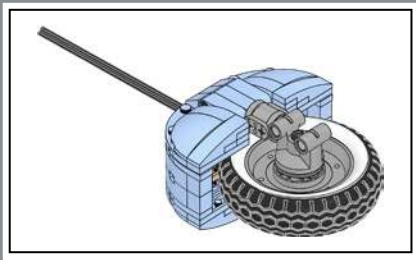

263

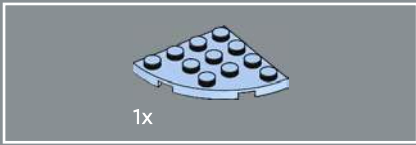
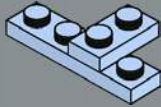

264

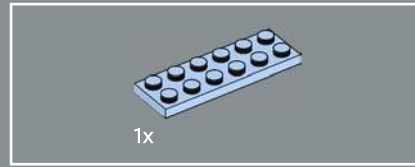
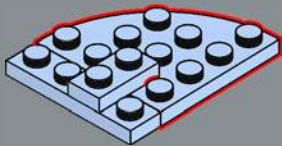

265

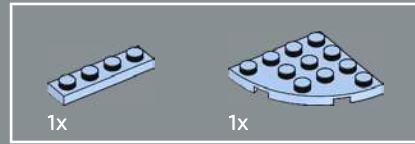
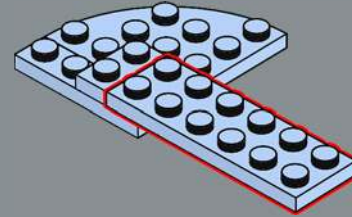

266

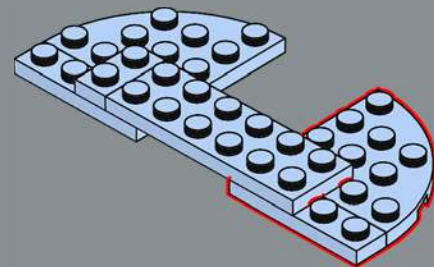



267

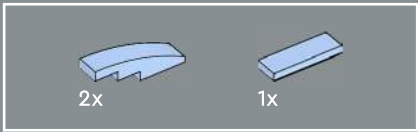
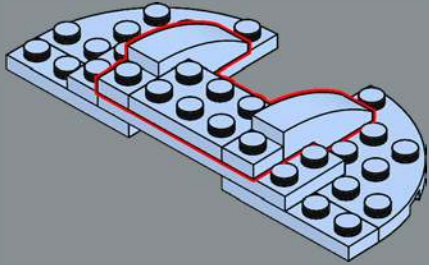

268

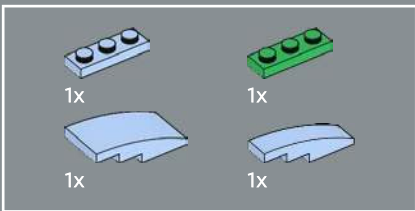
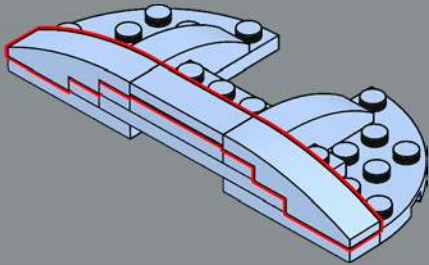

269

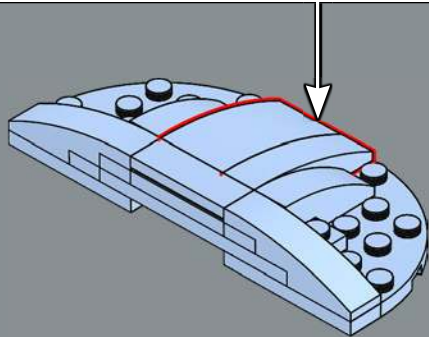
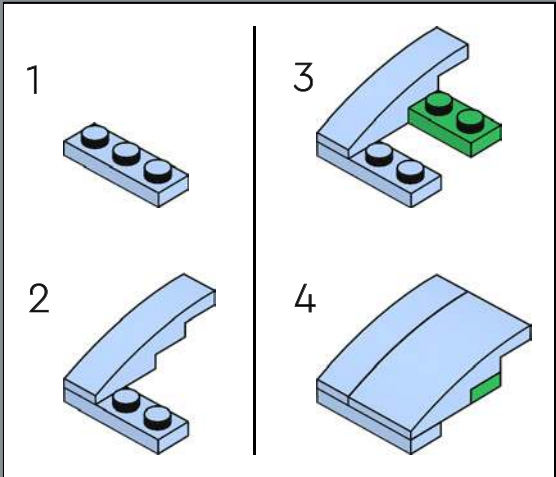



270

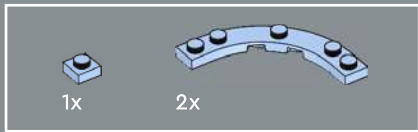
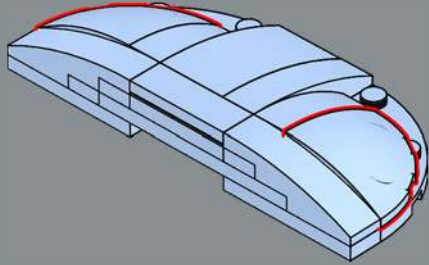

271

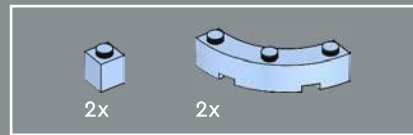
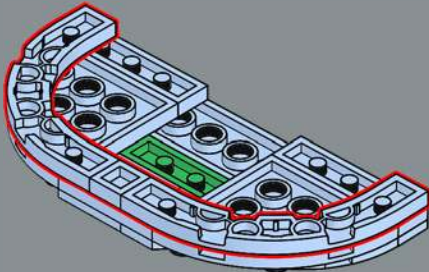

272

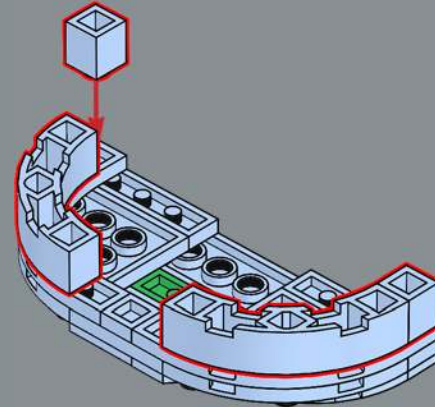

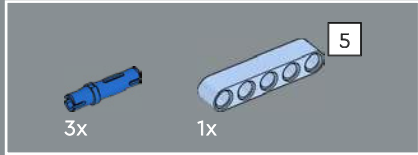
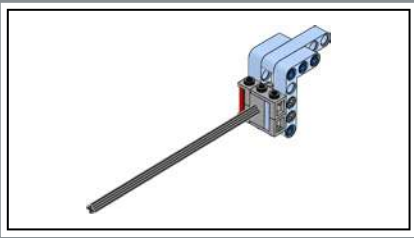

273

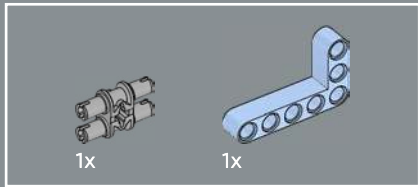
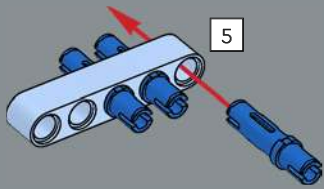

274

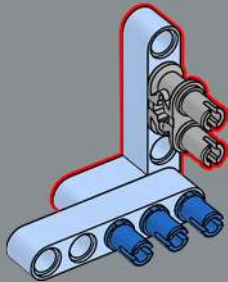

275

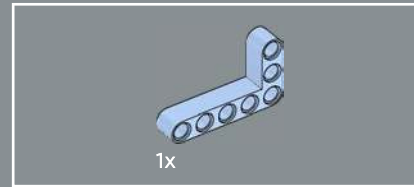
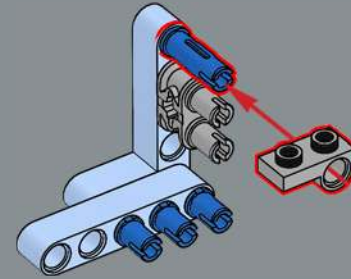

276

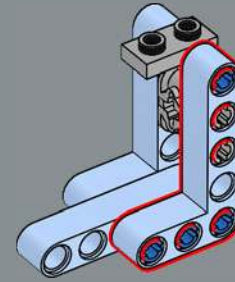

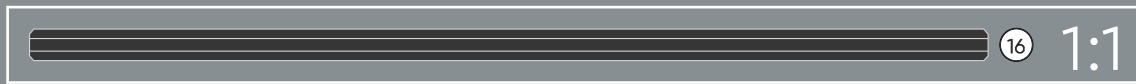
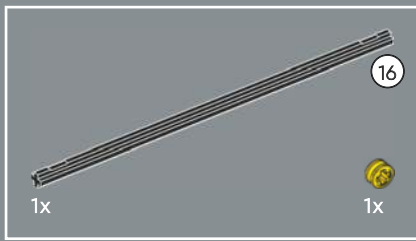

277

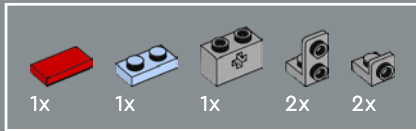
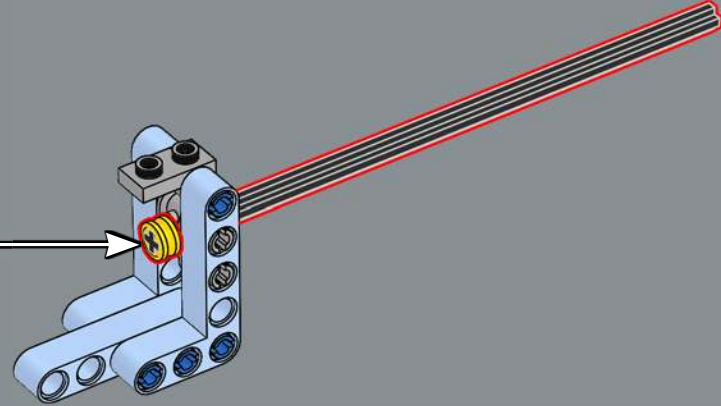
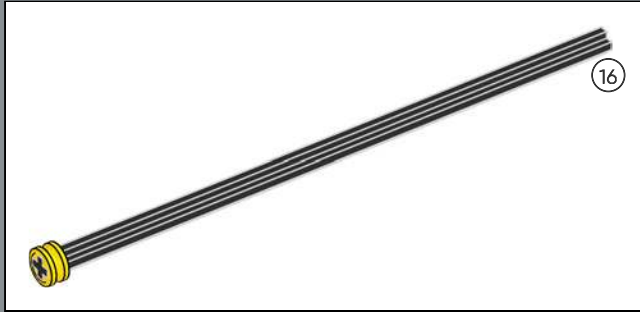

278

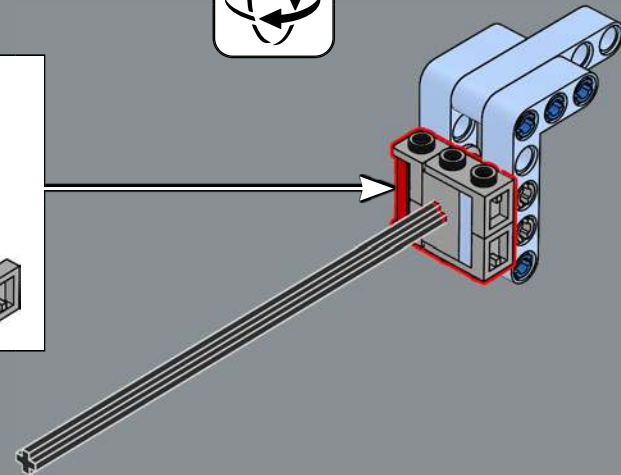
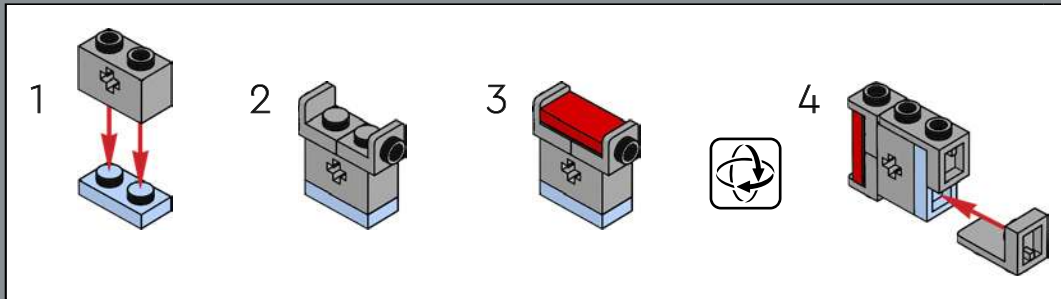

279

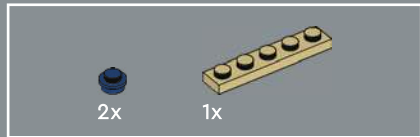
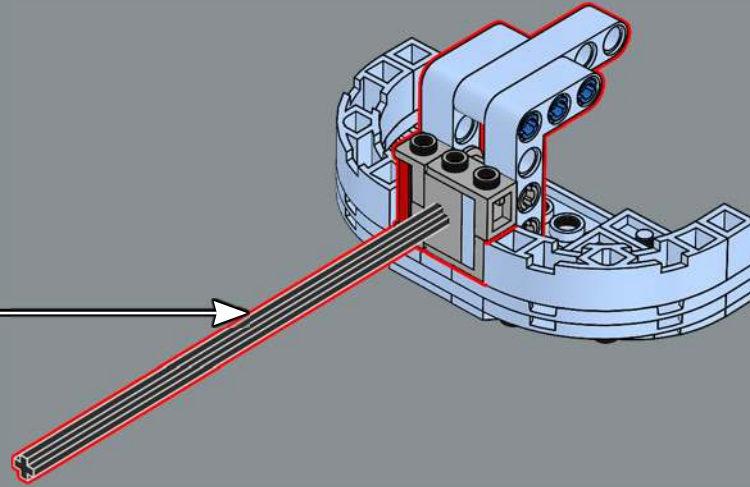

280

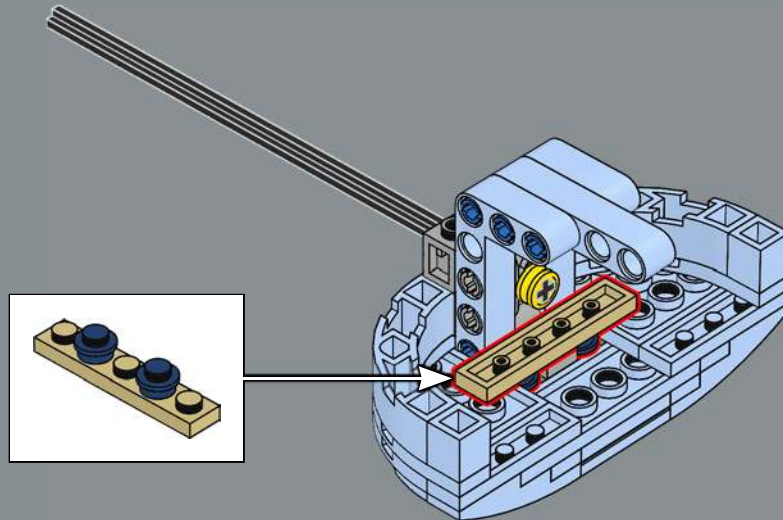

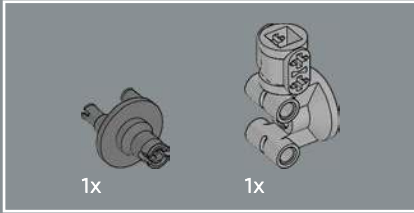

281

CLICK KLICK
CLIC CLIQUE
KATT KLIKŠKIS
咔嗒

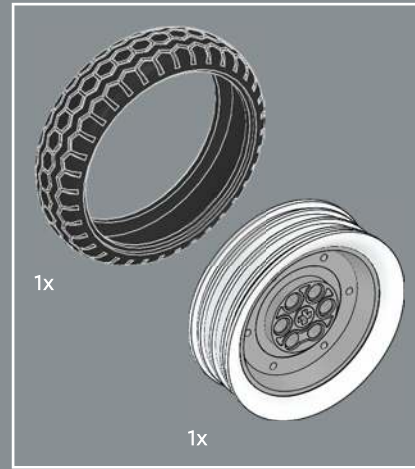
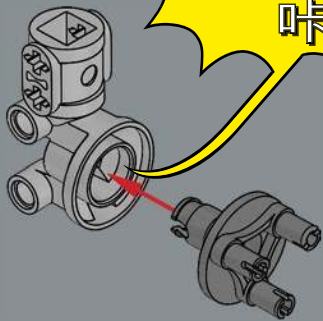

282

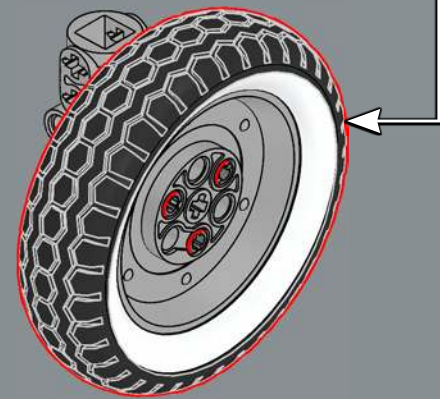
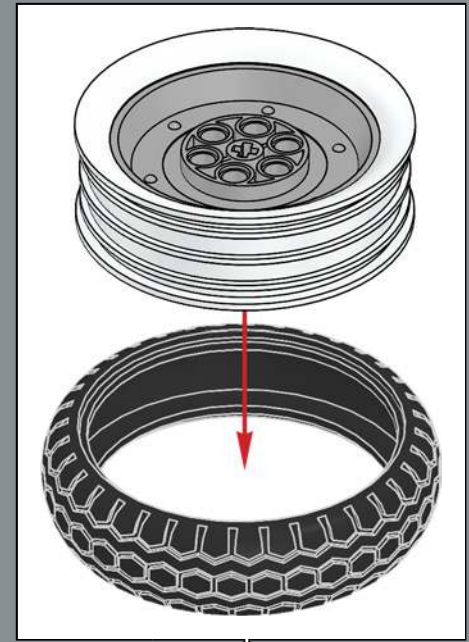

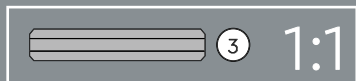
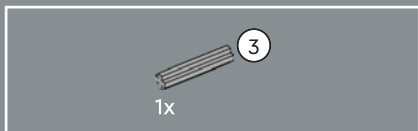

283

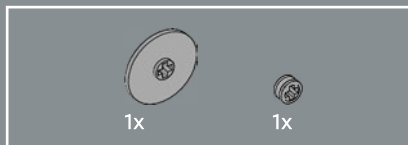

284

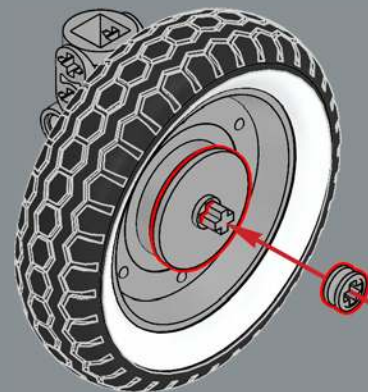

285

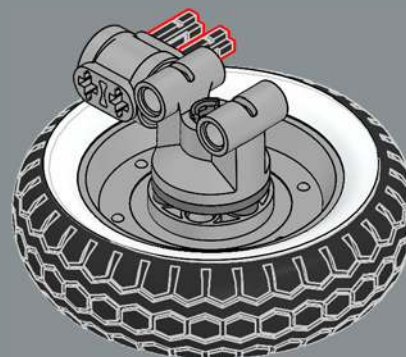

286

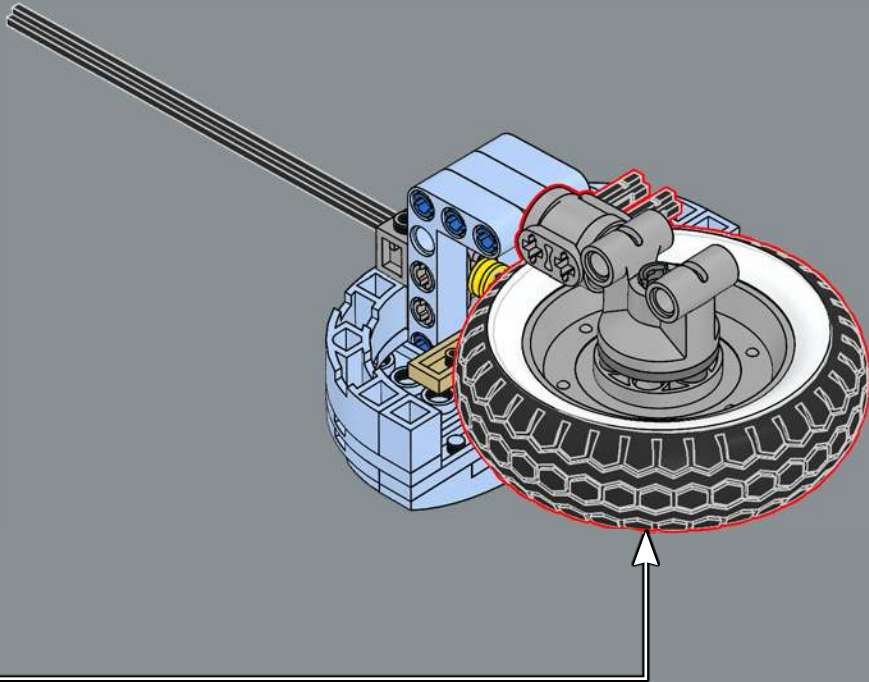

287

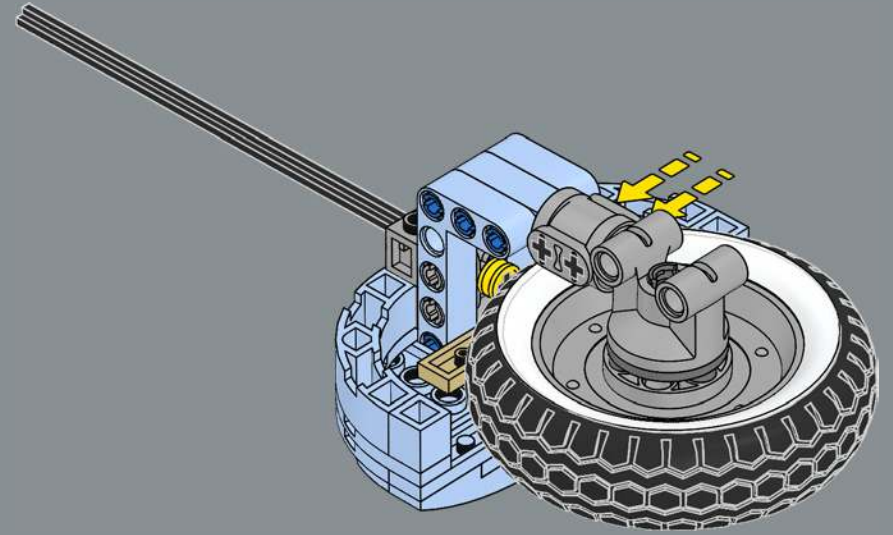

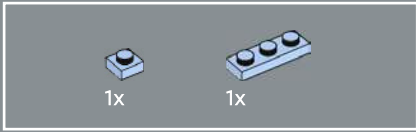
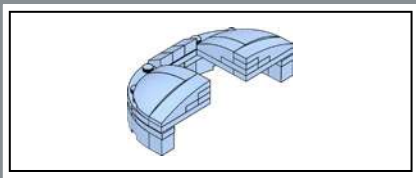

288

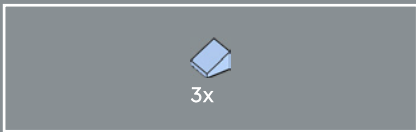
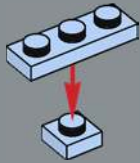

289

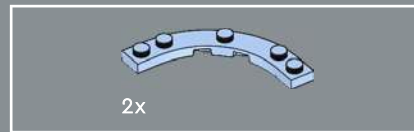
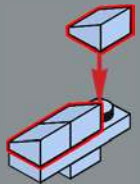

290

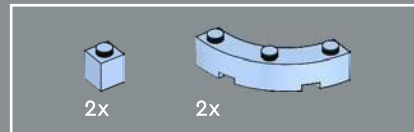
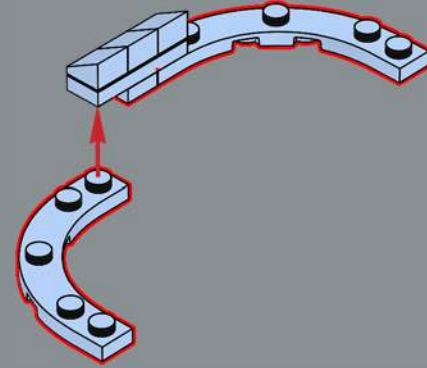

291

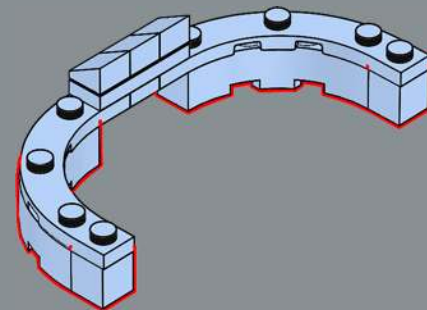

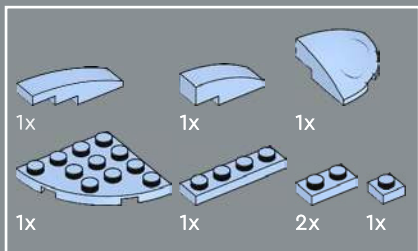

292

1

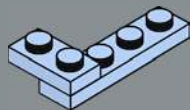

2

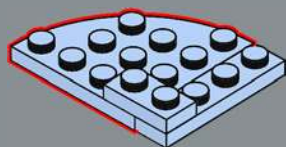

3

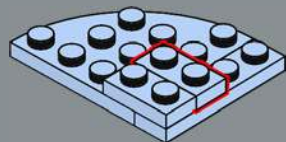

4

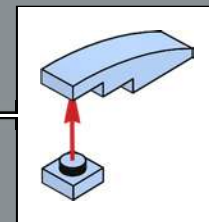
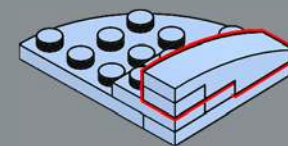

5

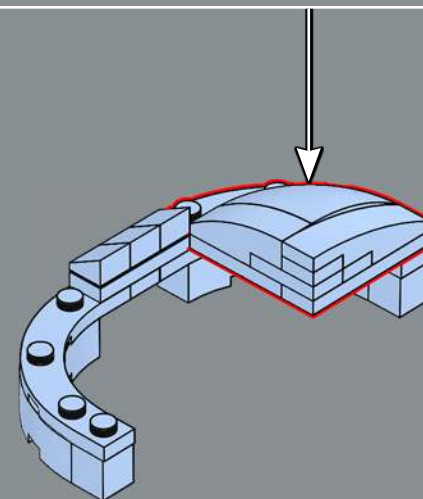
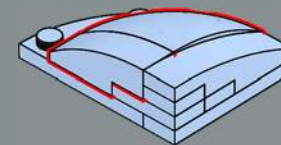

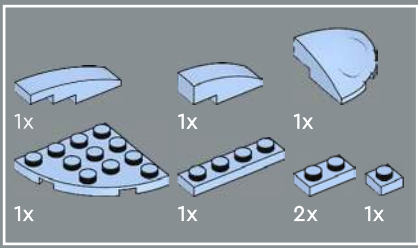

293

1

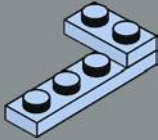

2

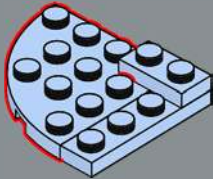

3

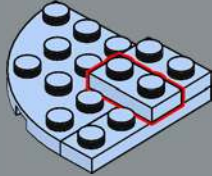

4

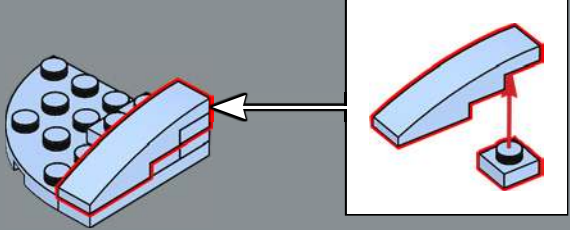

5

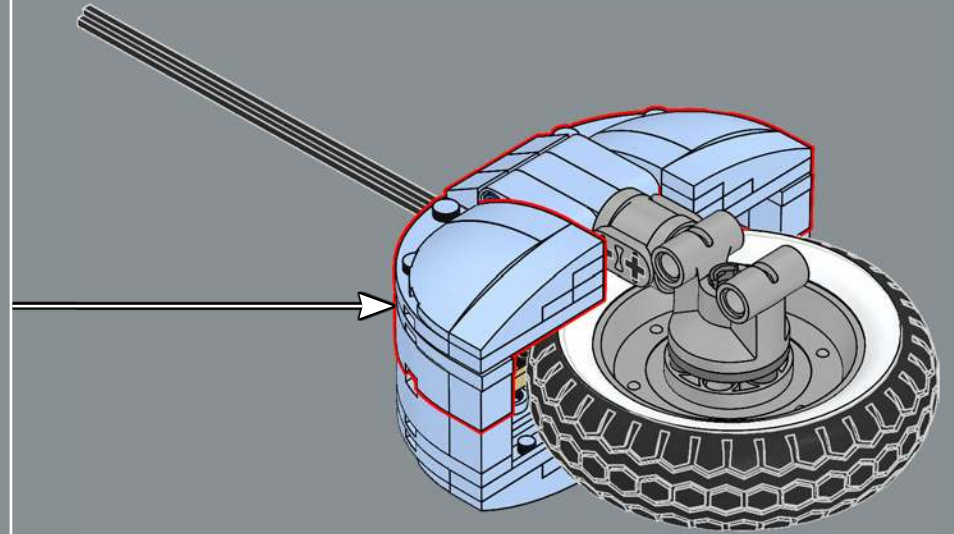
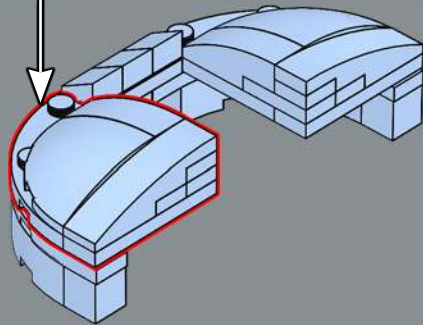
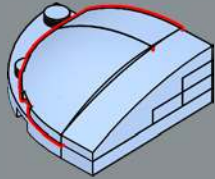



1x

294

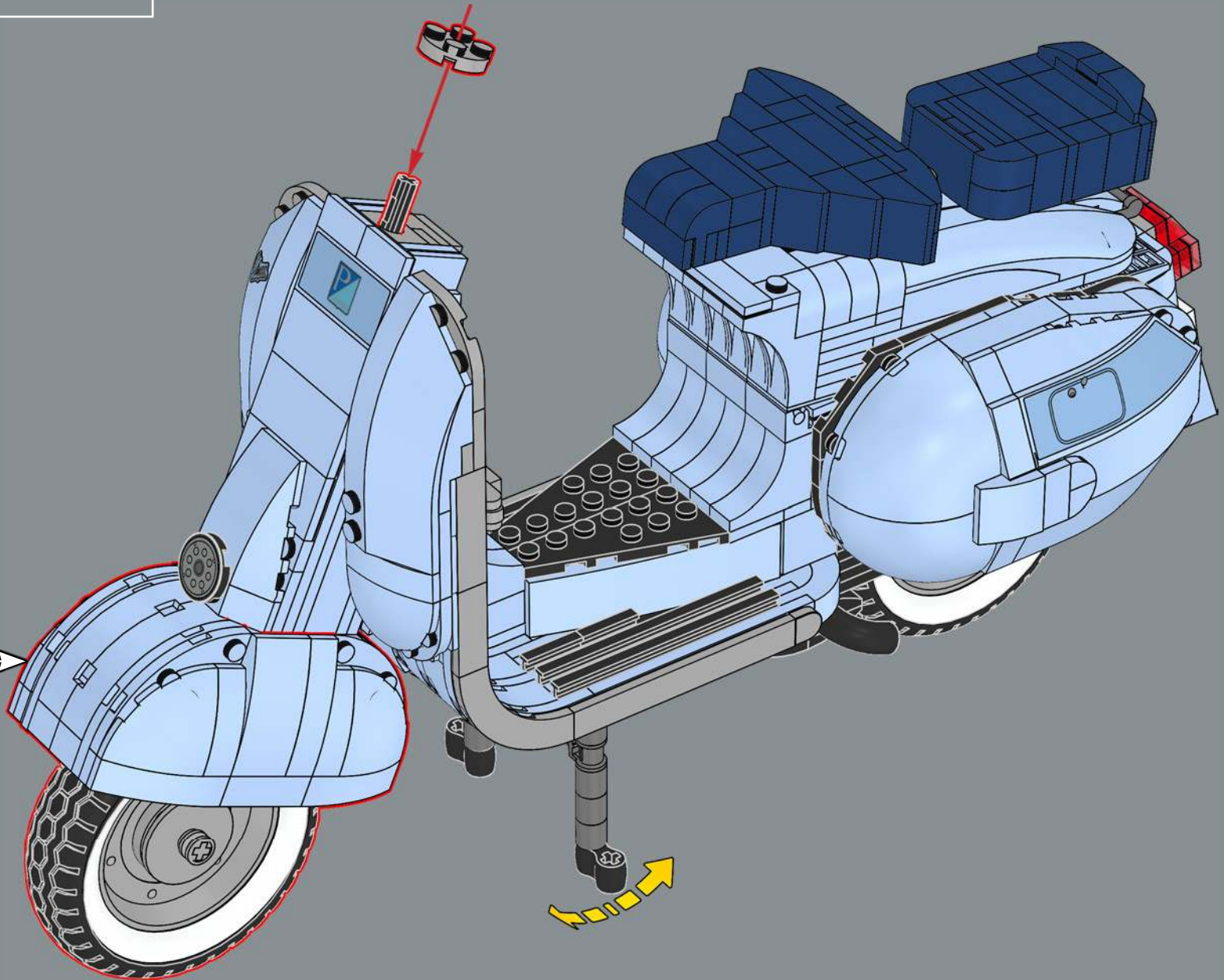

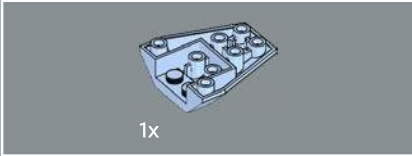
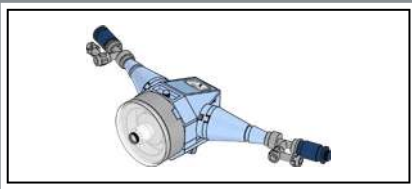

295

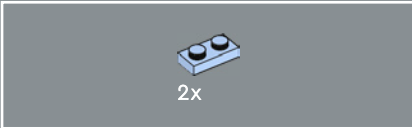
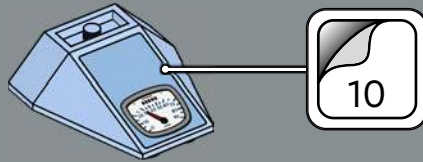

296

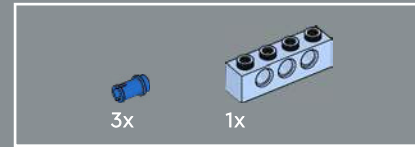
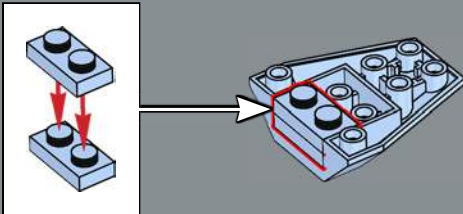

297

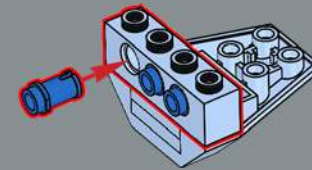

298

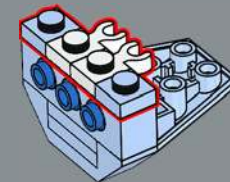

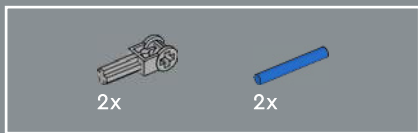

299

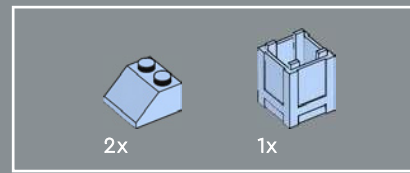
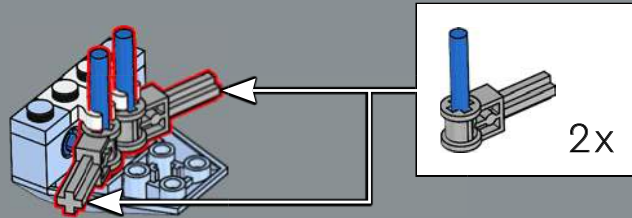

301

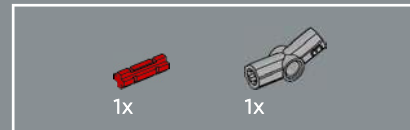
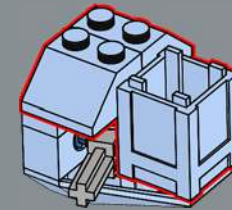

302

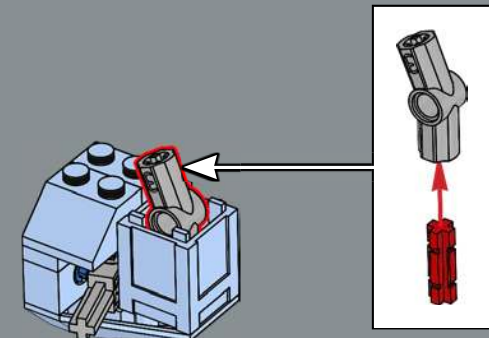

300

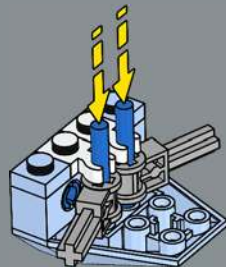

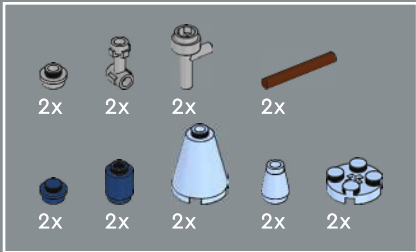

303

1

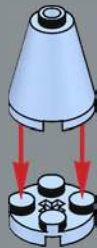

2

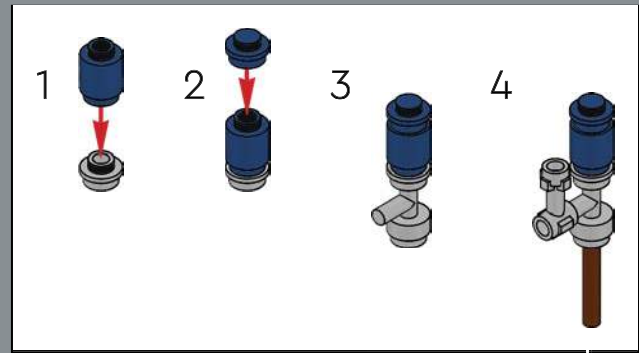

3

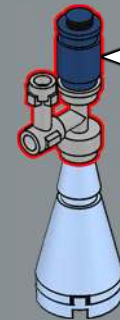

2x

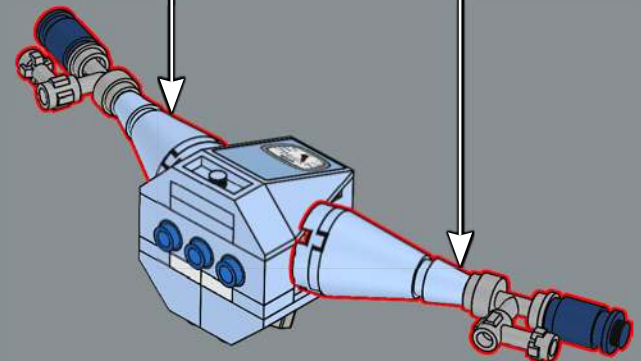

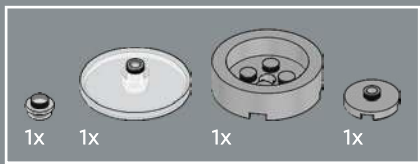

304

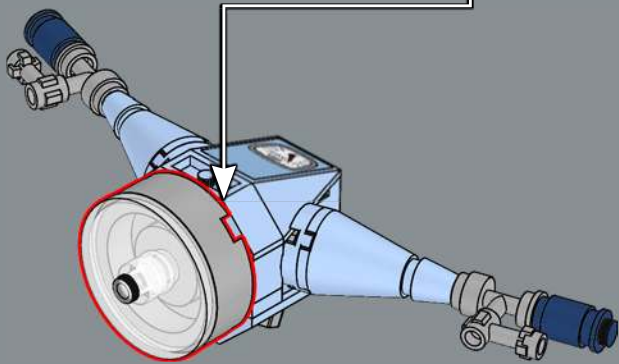
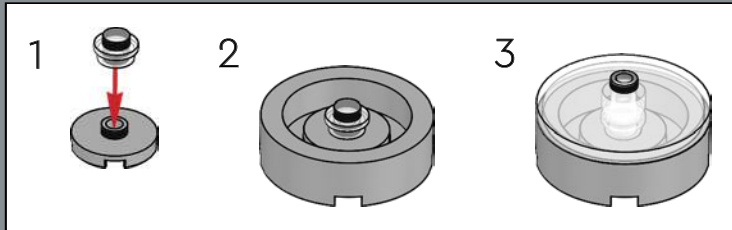

305

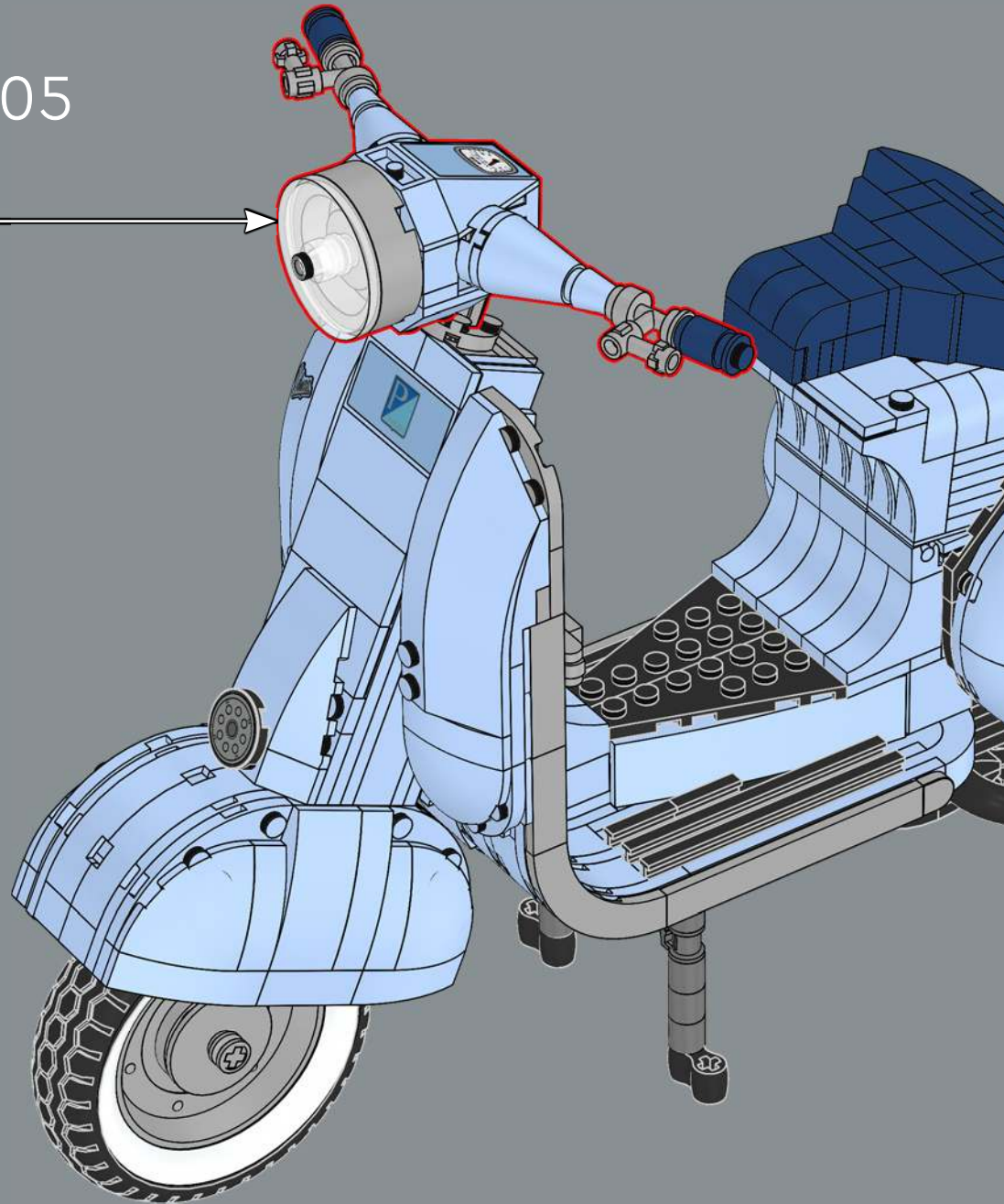

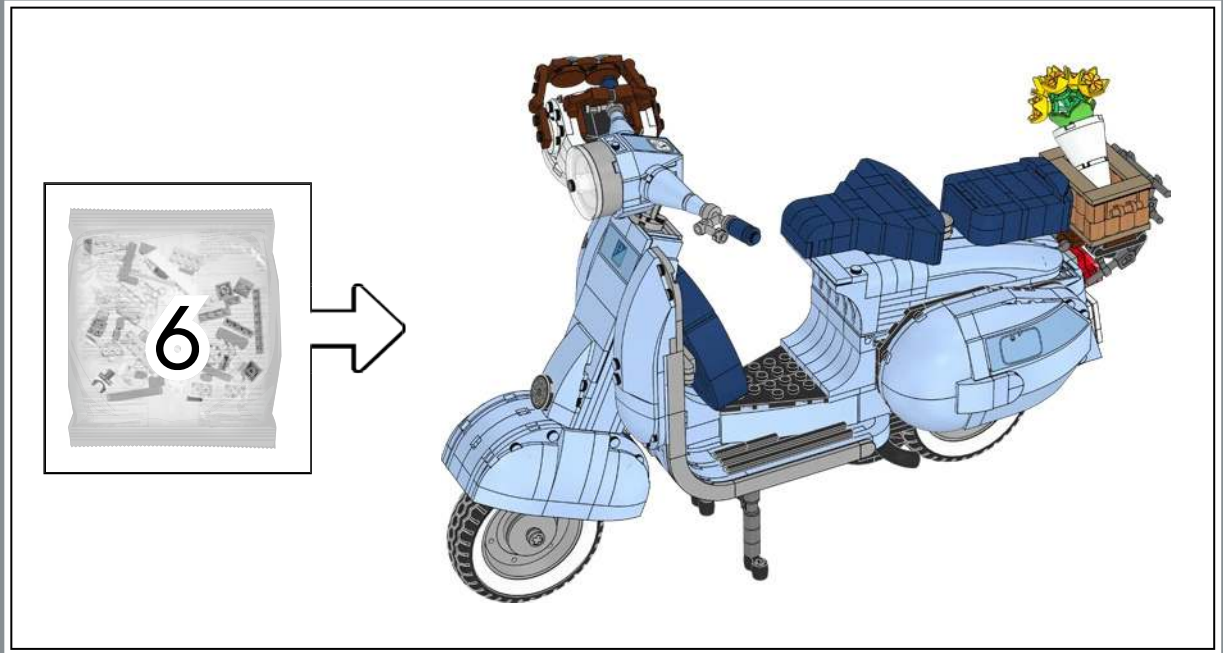
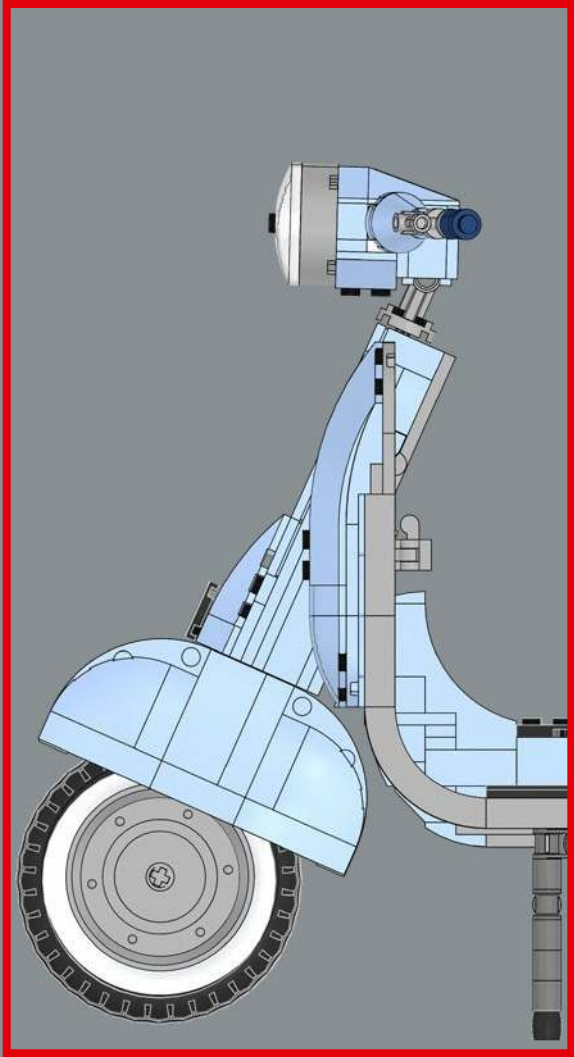

-  1x
-  1x
-  4x
-  1x
-  1x

306

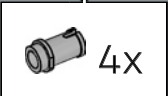
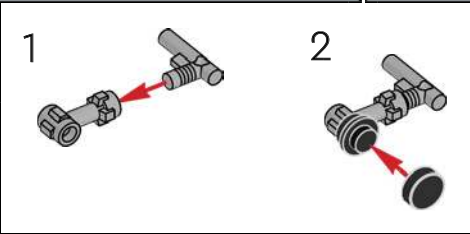
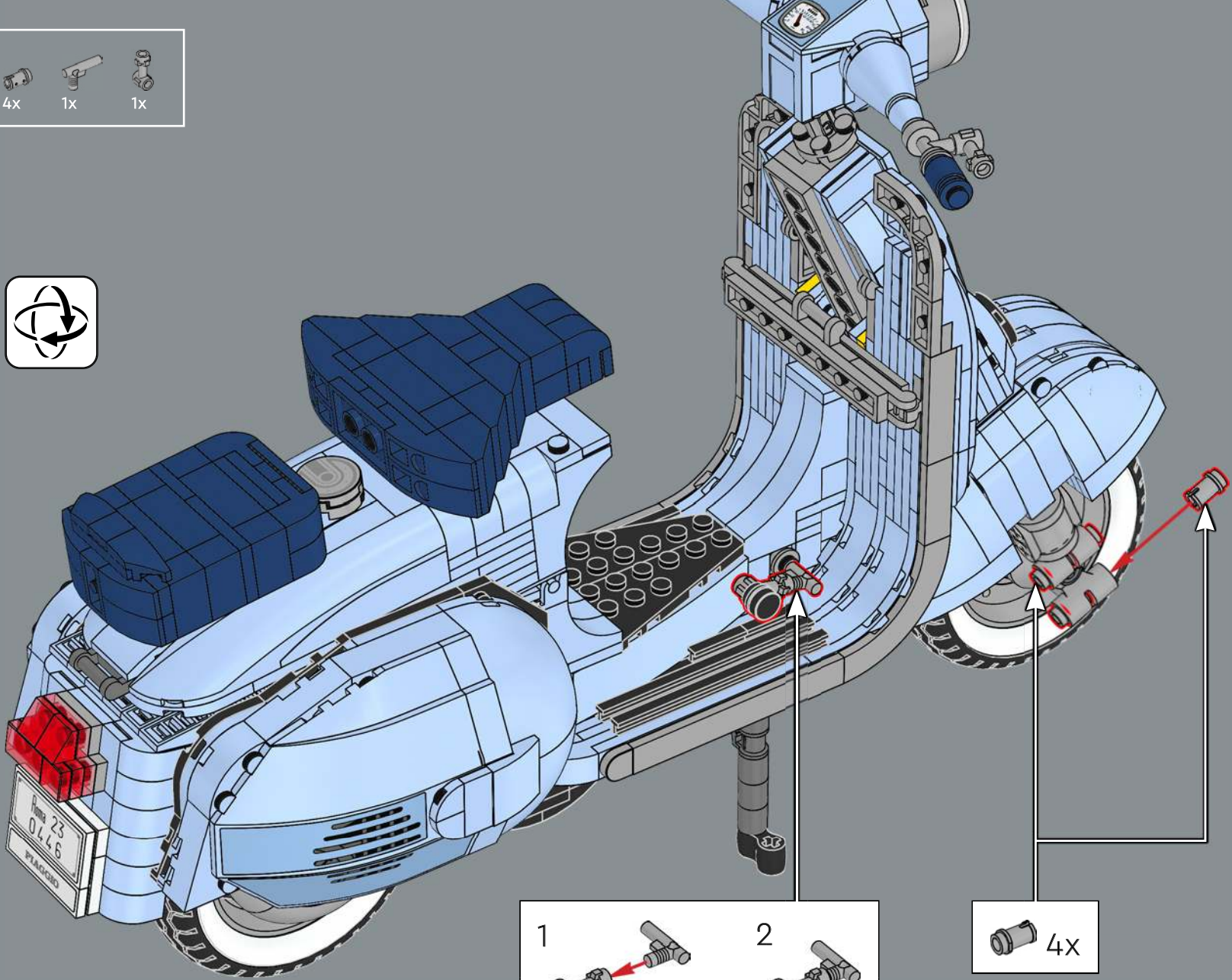

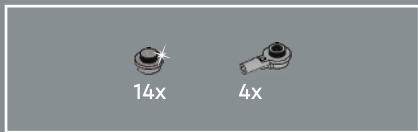

307

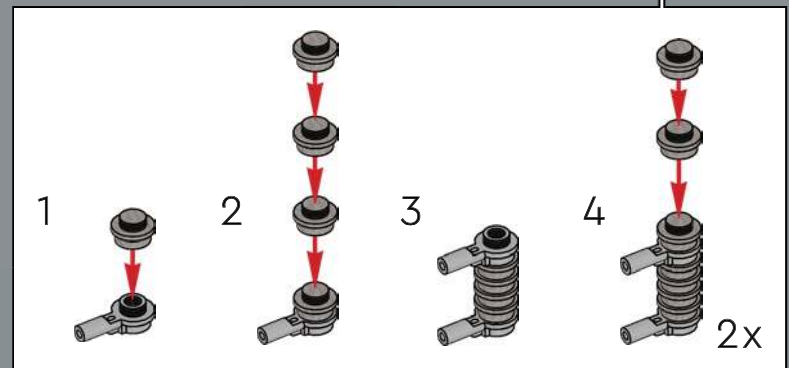
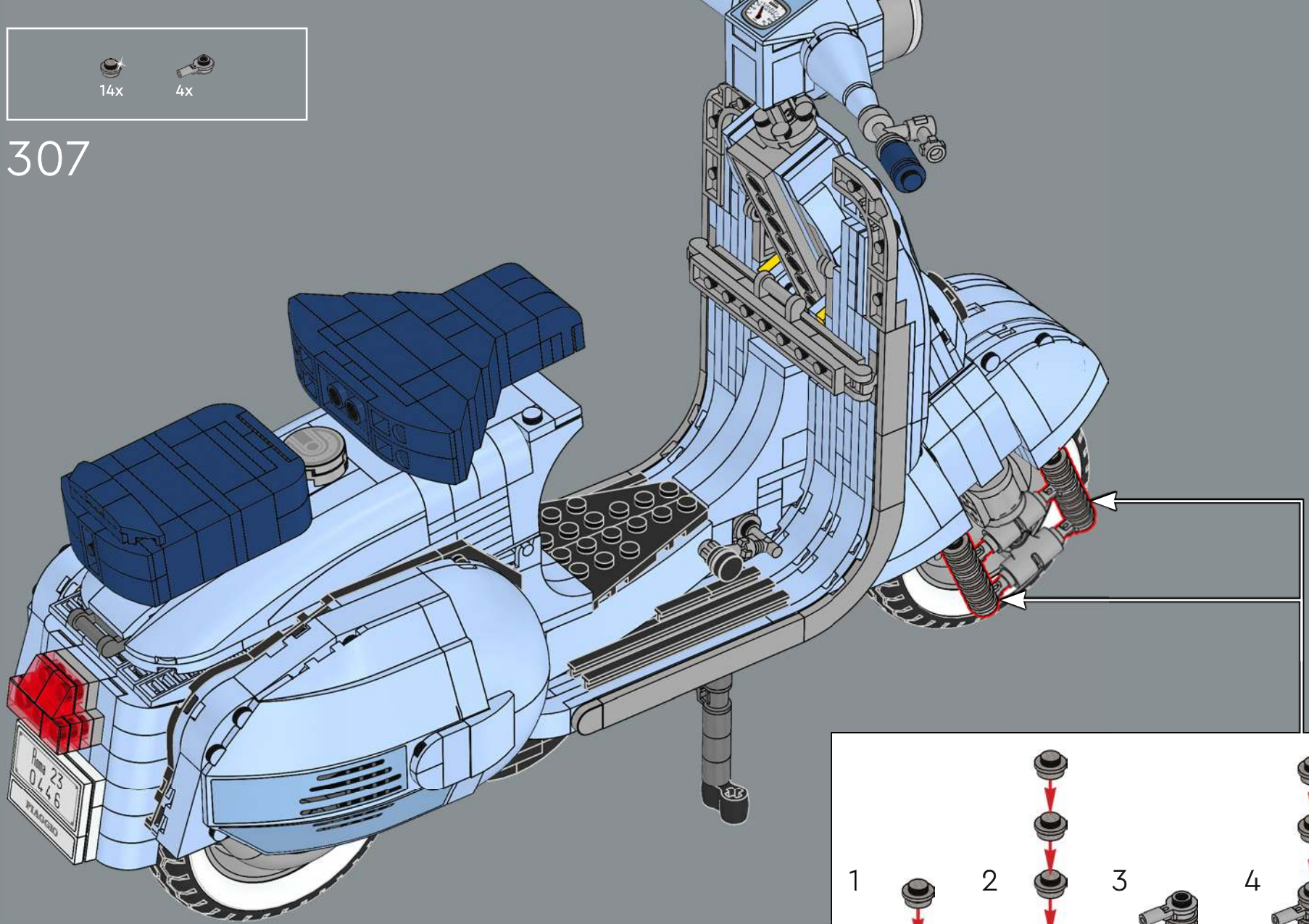



308

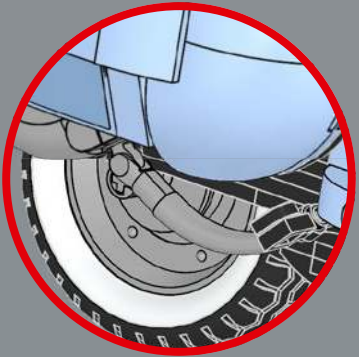
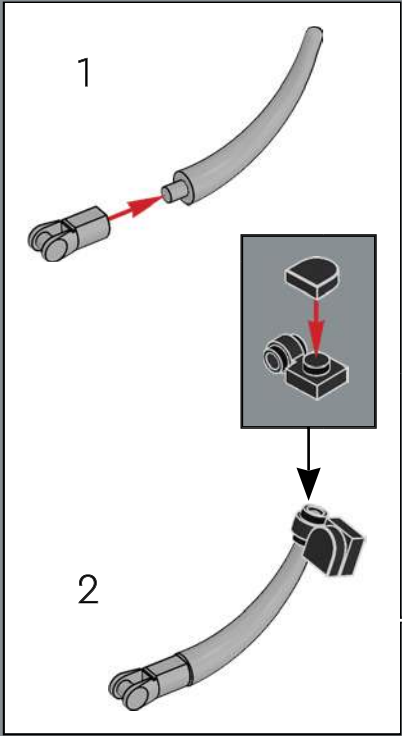
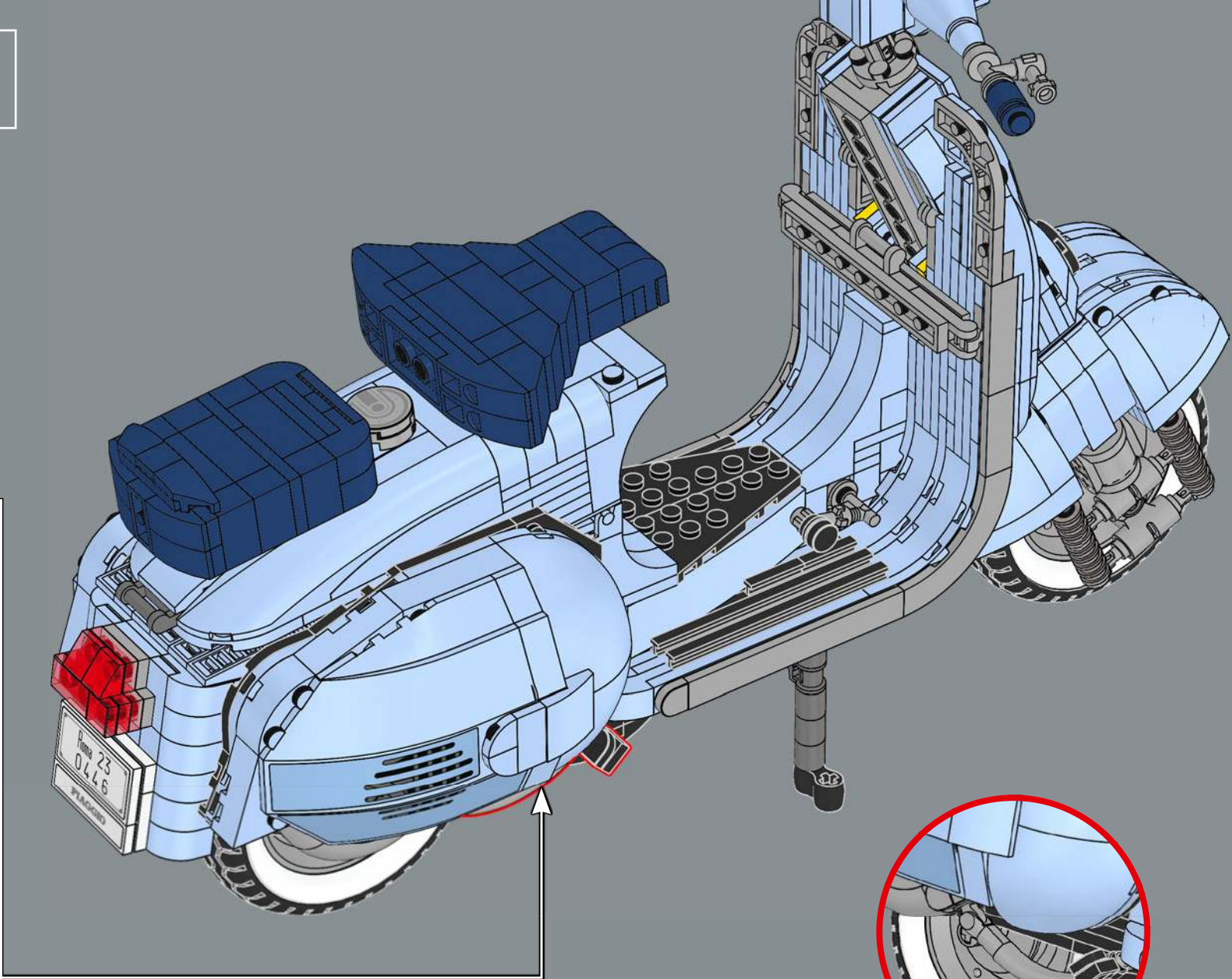

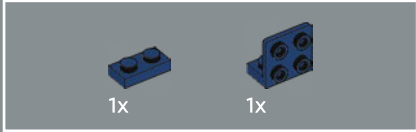
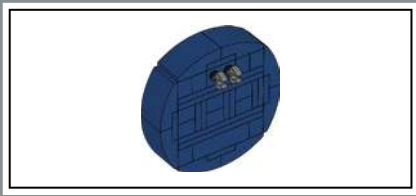

309

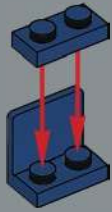

310

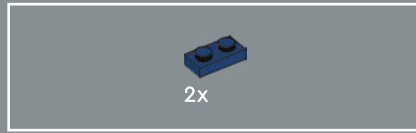
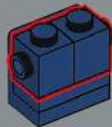

311

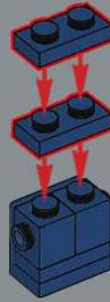

312

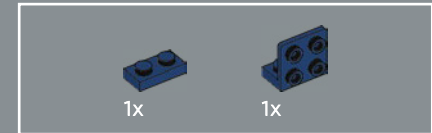
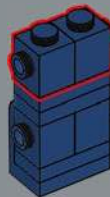

313

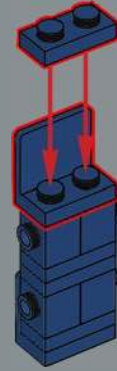

314

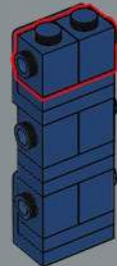

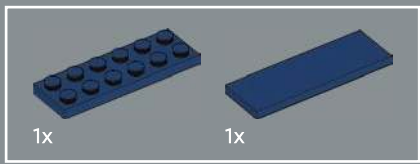

315

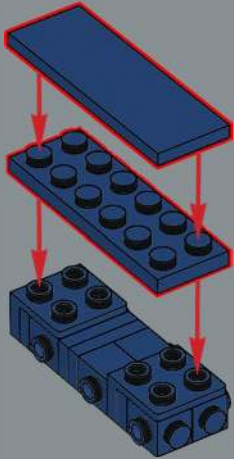

316

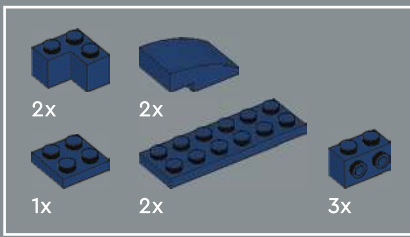
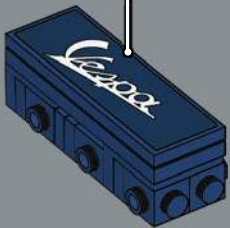

317

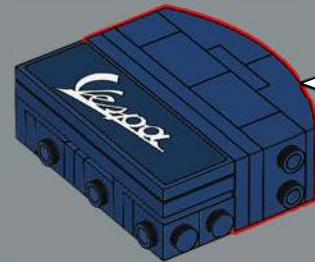
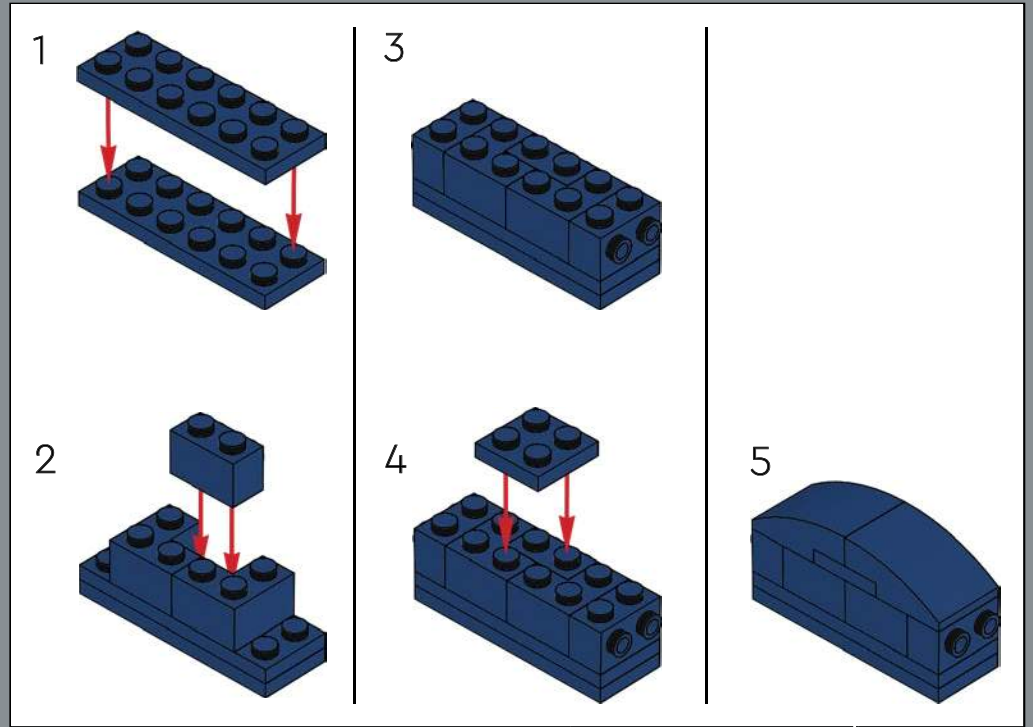

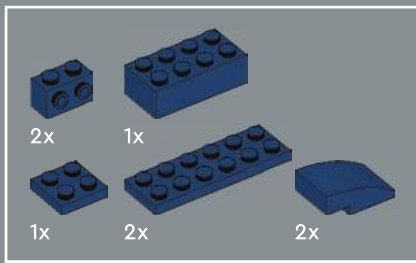

318

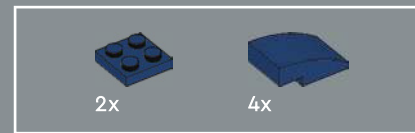
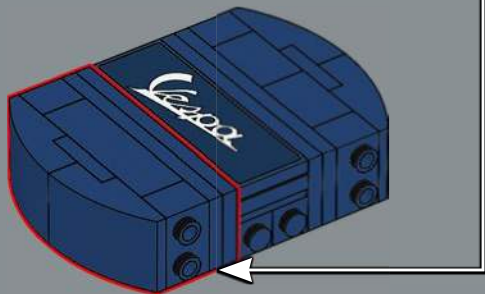
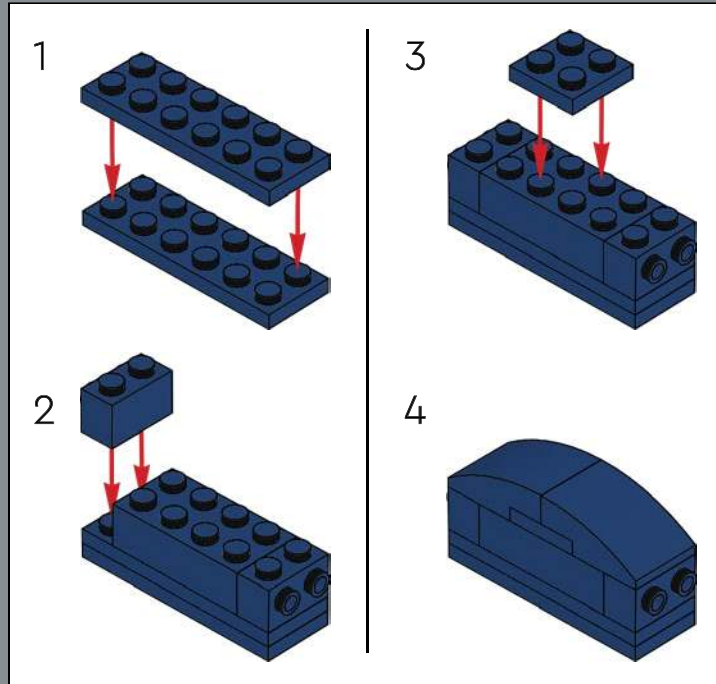

319

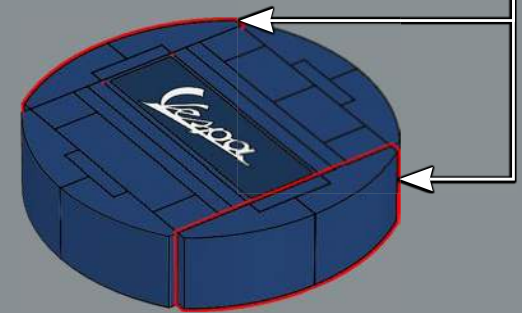
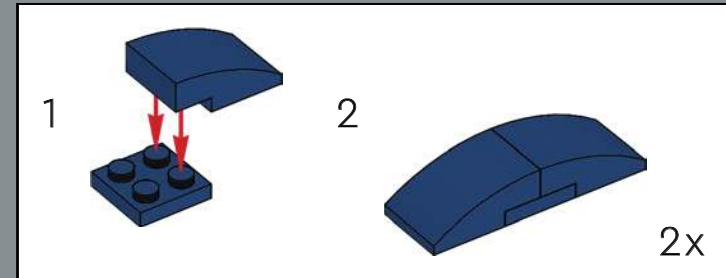

320

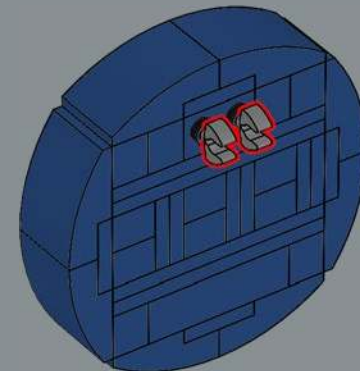

321

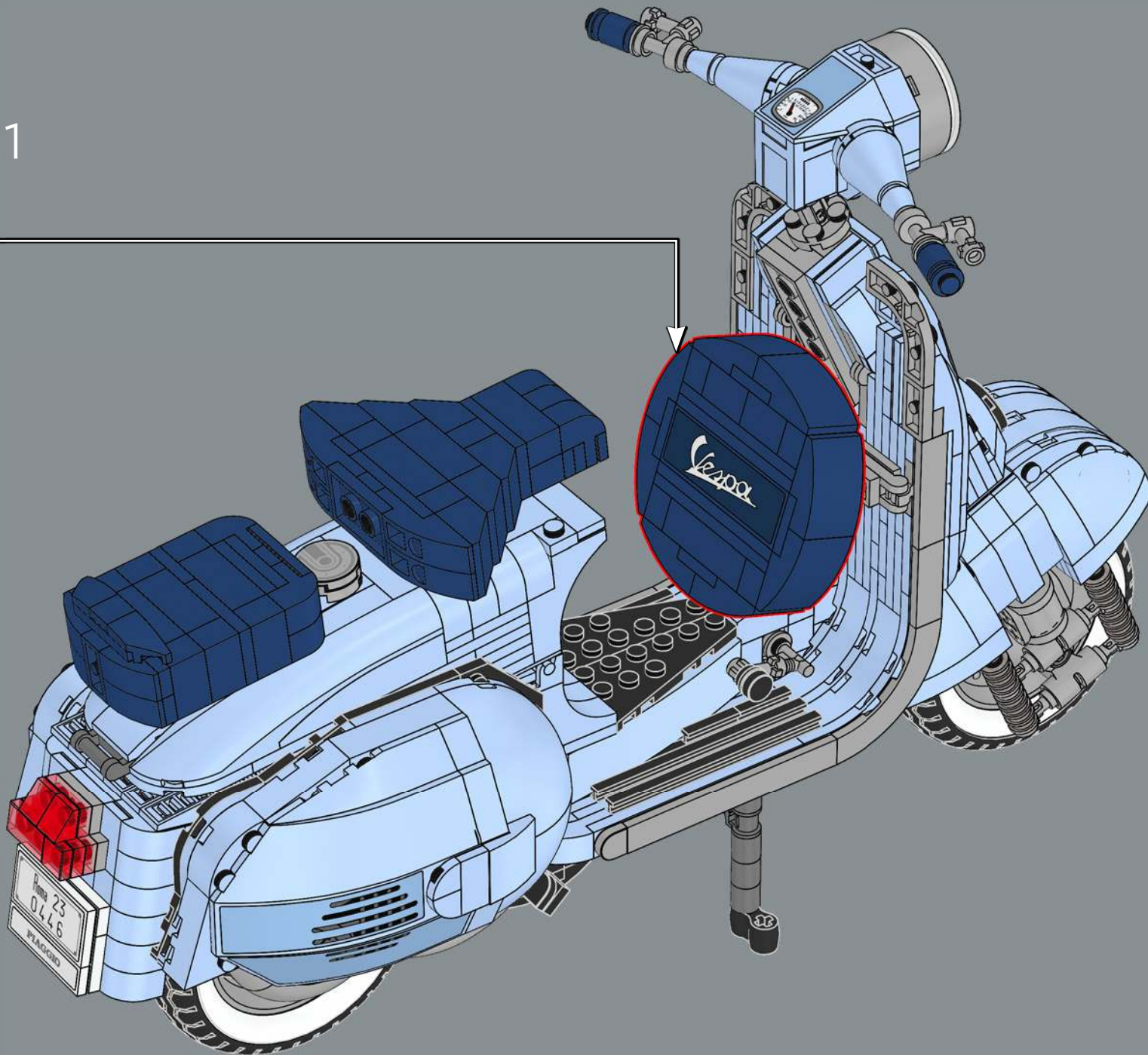

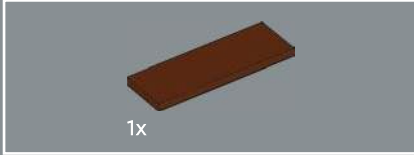
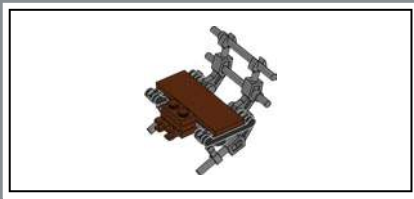

322

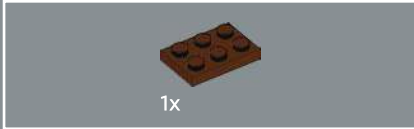

323

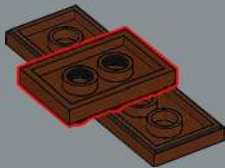

324



2x 2x

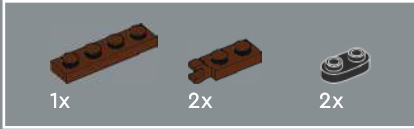

325



1x 2x 2x

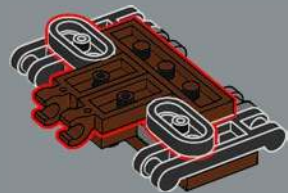

326



2x

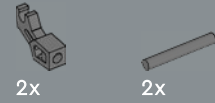
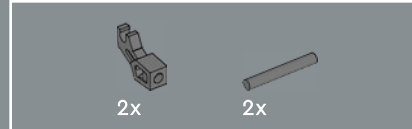
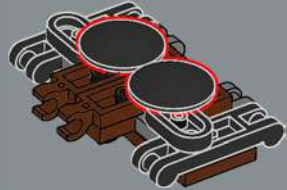

2x 2x

327

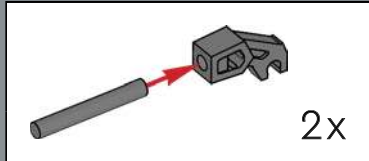

2x

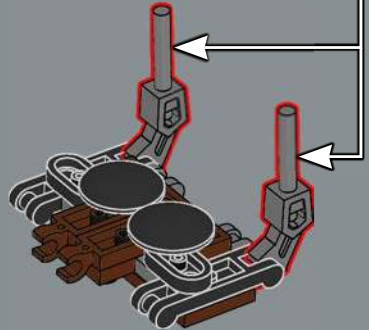



328

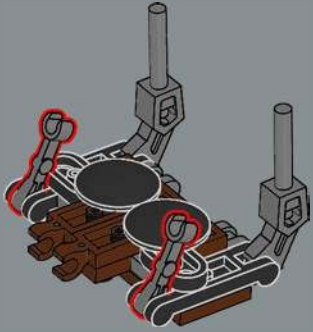

329

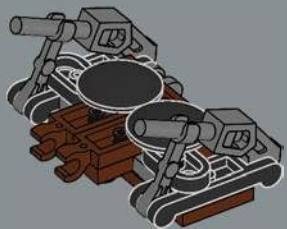

330

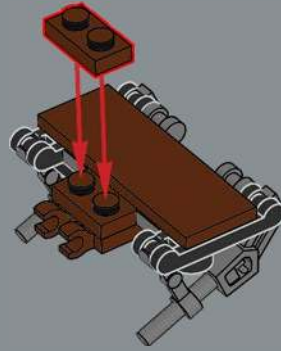

331

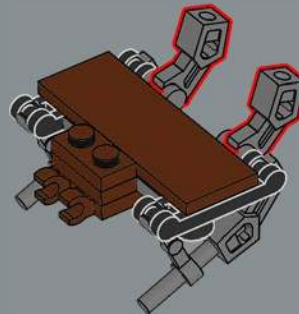

332

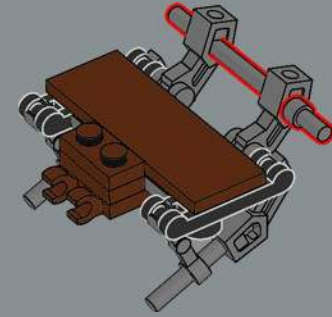

333

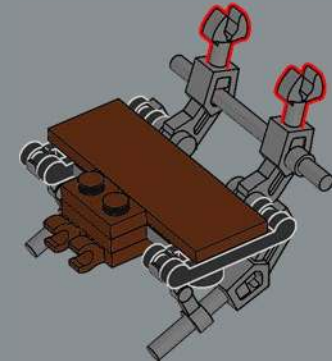

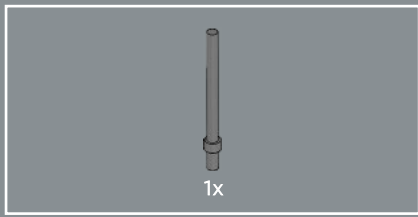

334

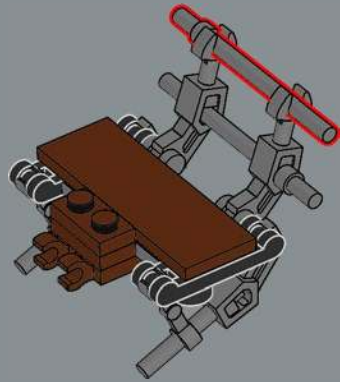

335

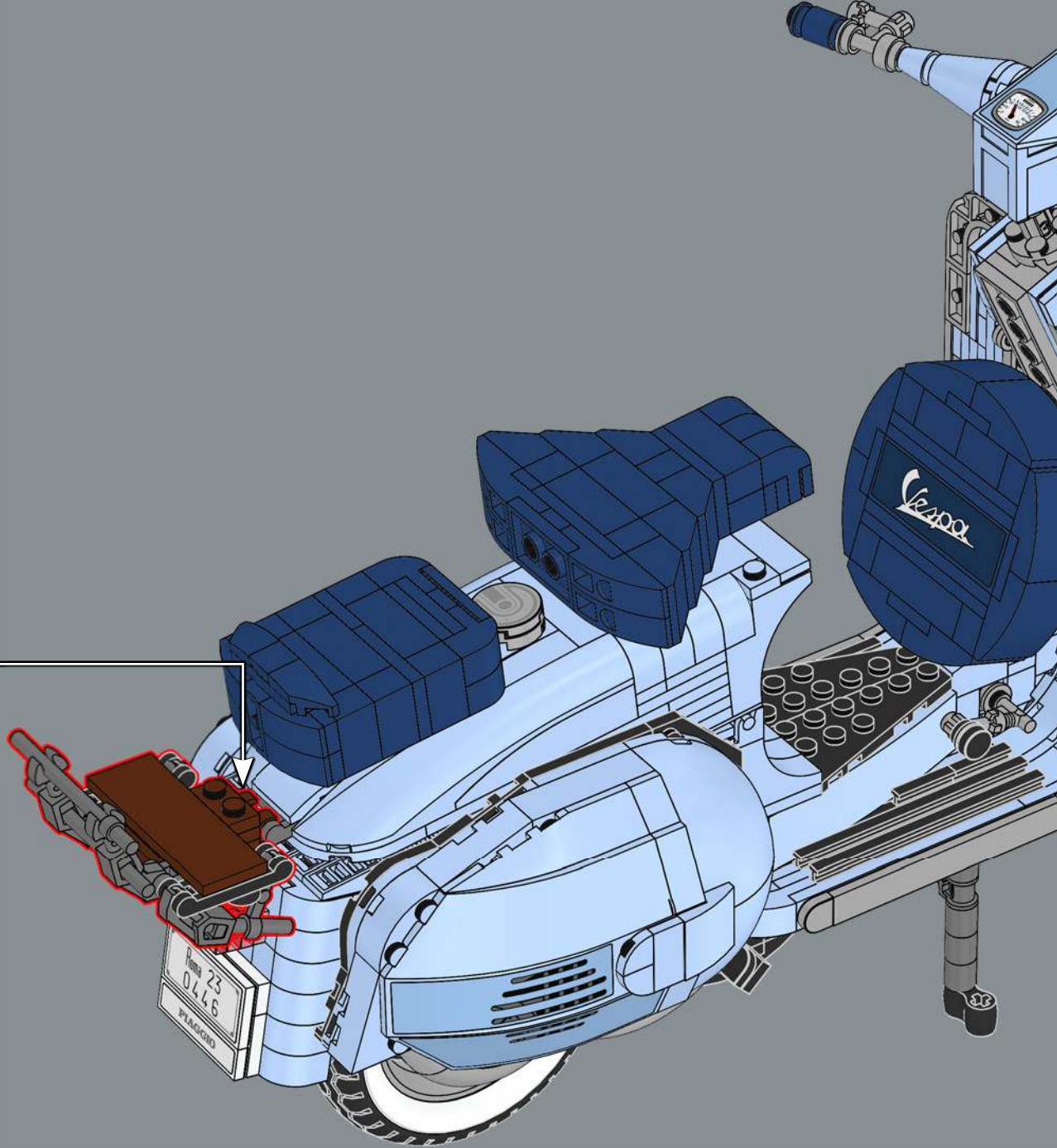

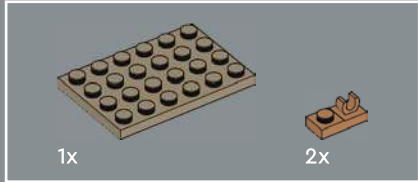

336

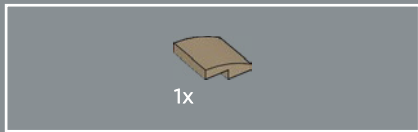
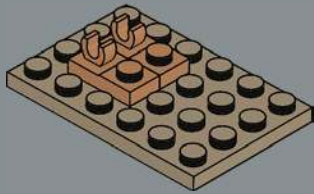

337

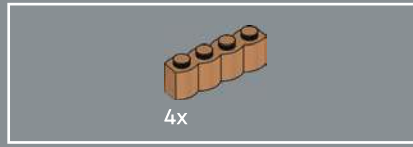
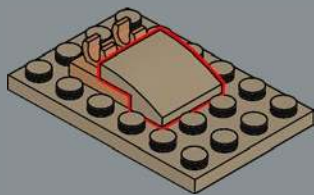

338

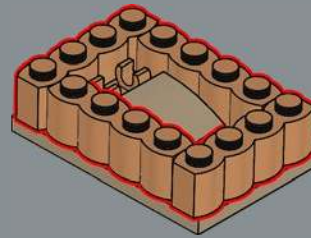

339

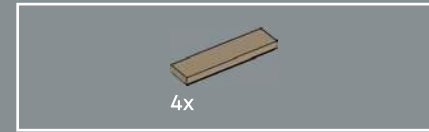
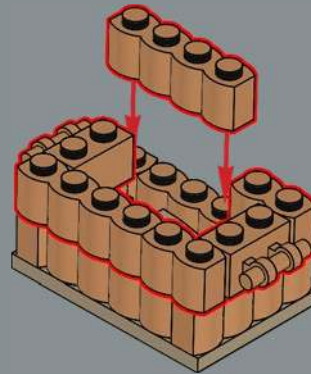

340

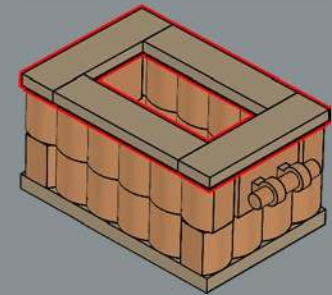

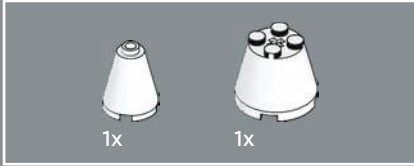

341

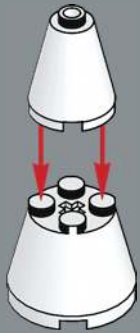

342

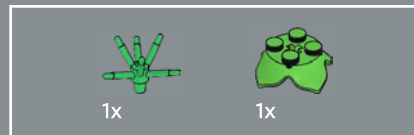
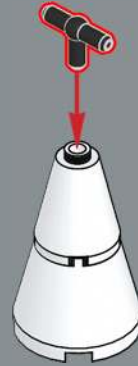

343

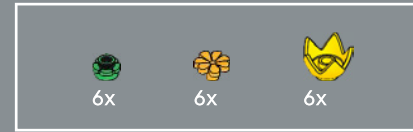
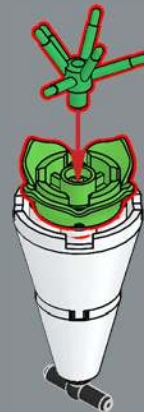

344

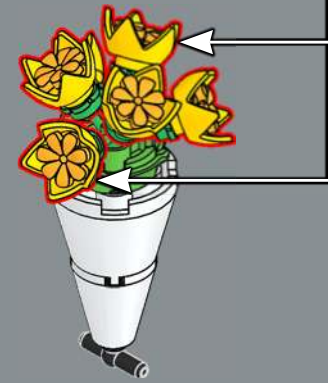
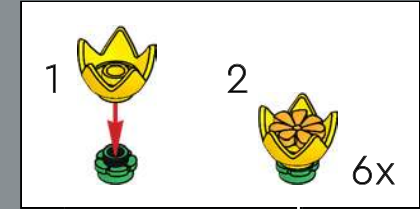

345

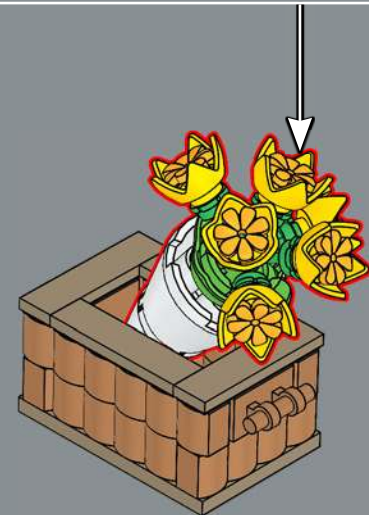

Thanks to popular culture, the Vespa has been elevated from a simple means of transportation to an Italian style icon appreciated worldwide.

Grazie alla cultura popolare, la Vespa è stata elevata da semplice mezzo di trasporto a icona di stile italiano apprezzata in tutto il mondo.

346

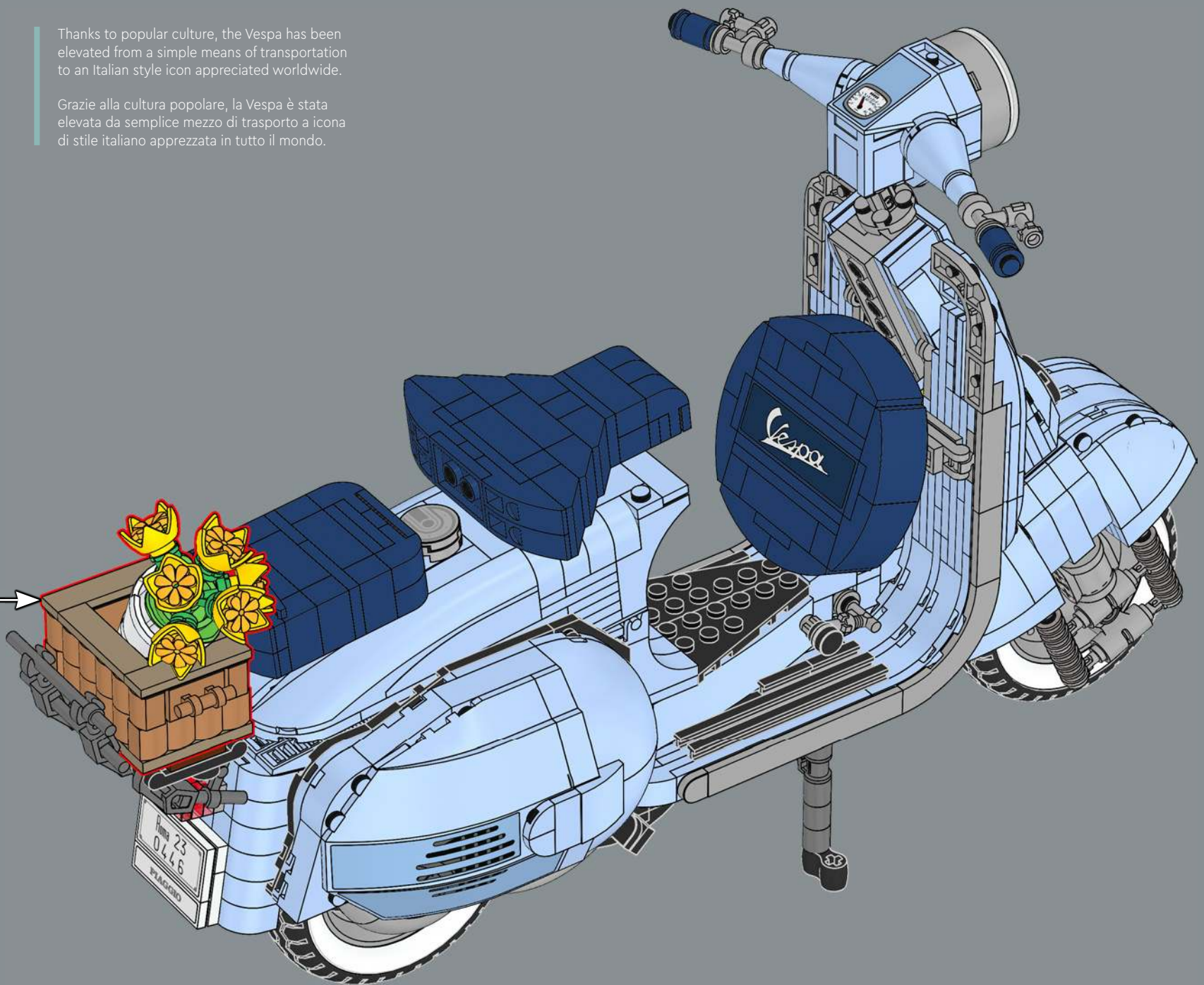

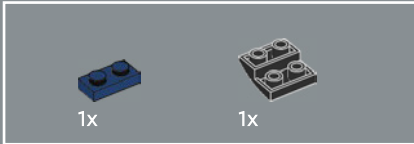

347

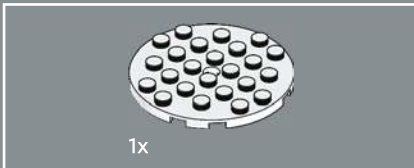
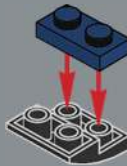

348

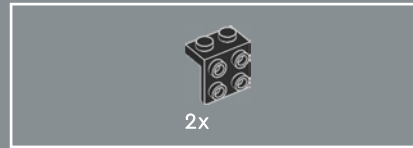
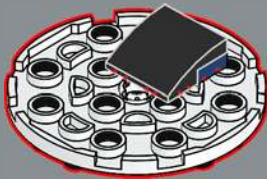

349

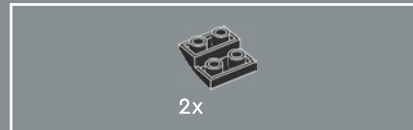
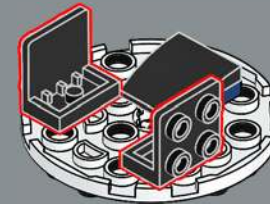

350

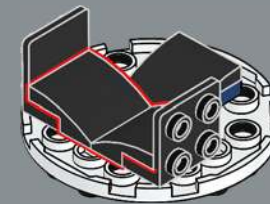

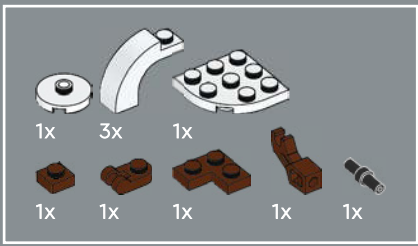

351

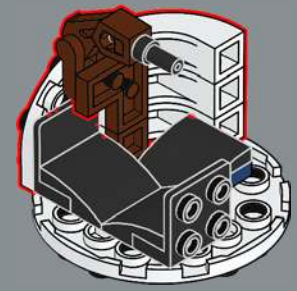
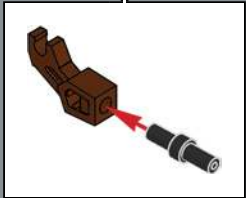
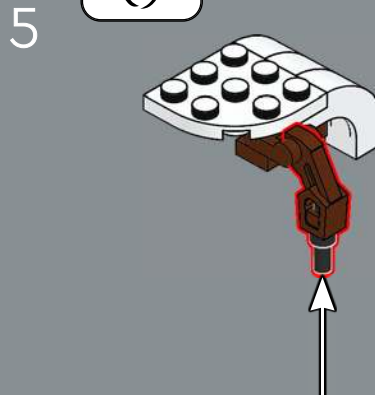
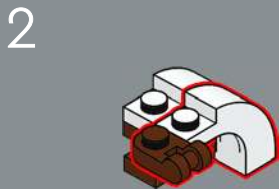
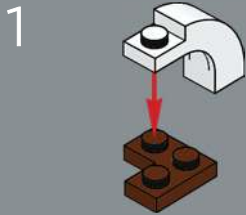

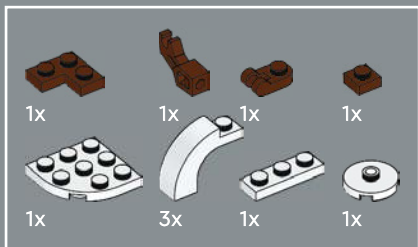

352

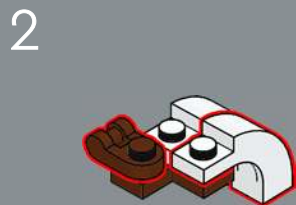
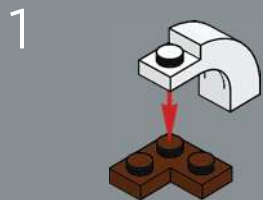

3



4



5

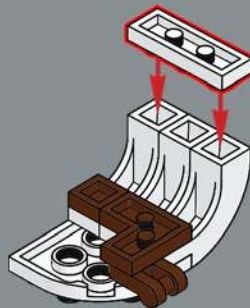

6

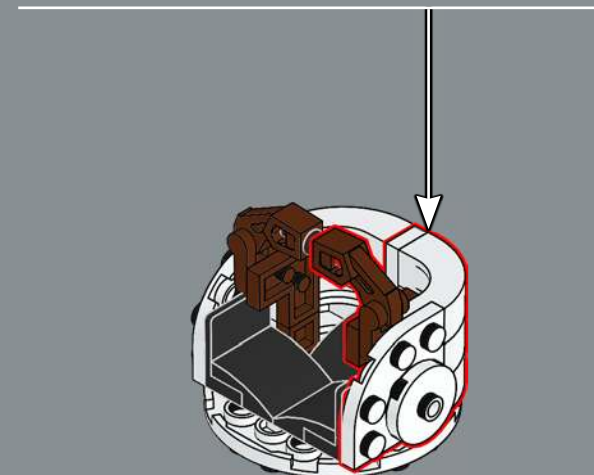
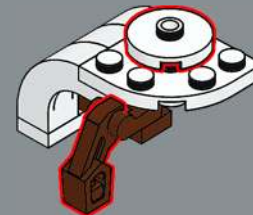



353

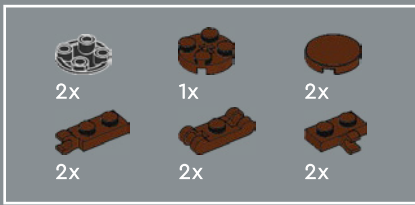

354

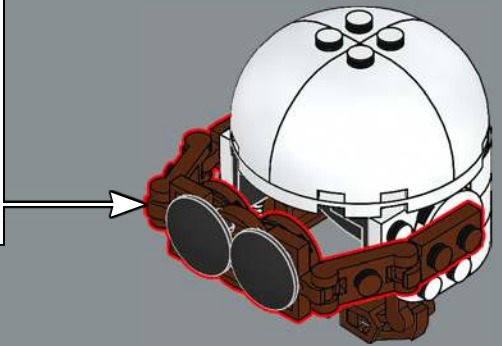
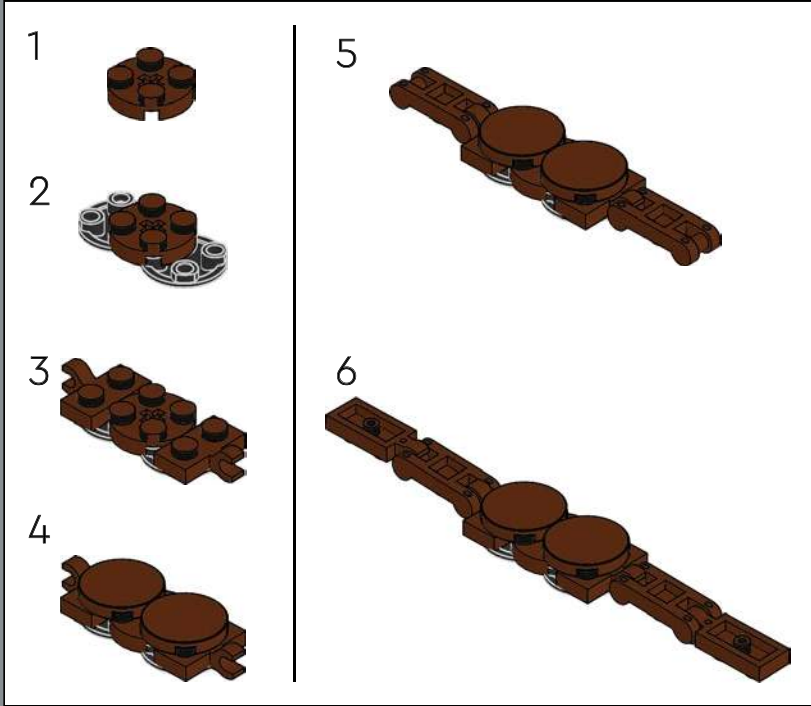
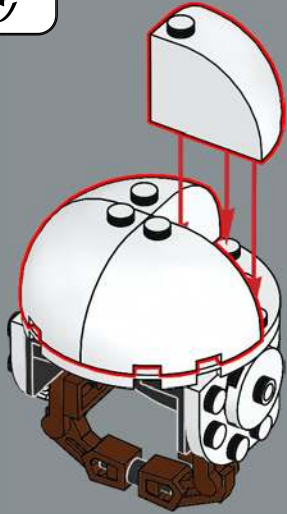

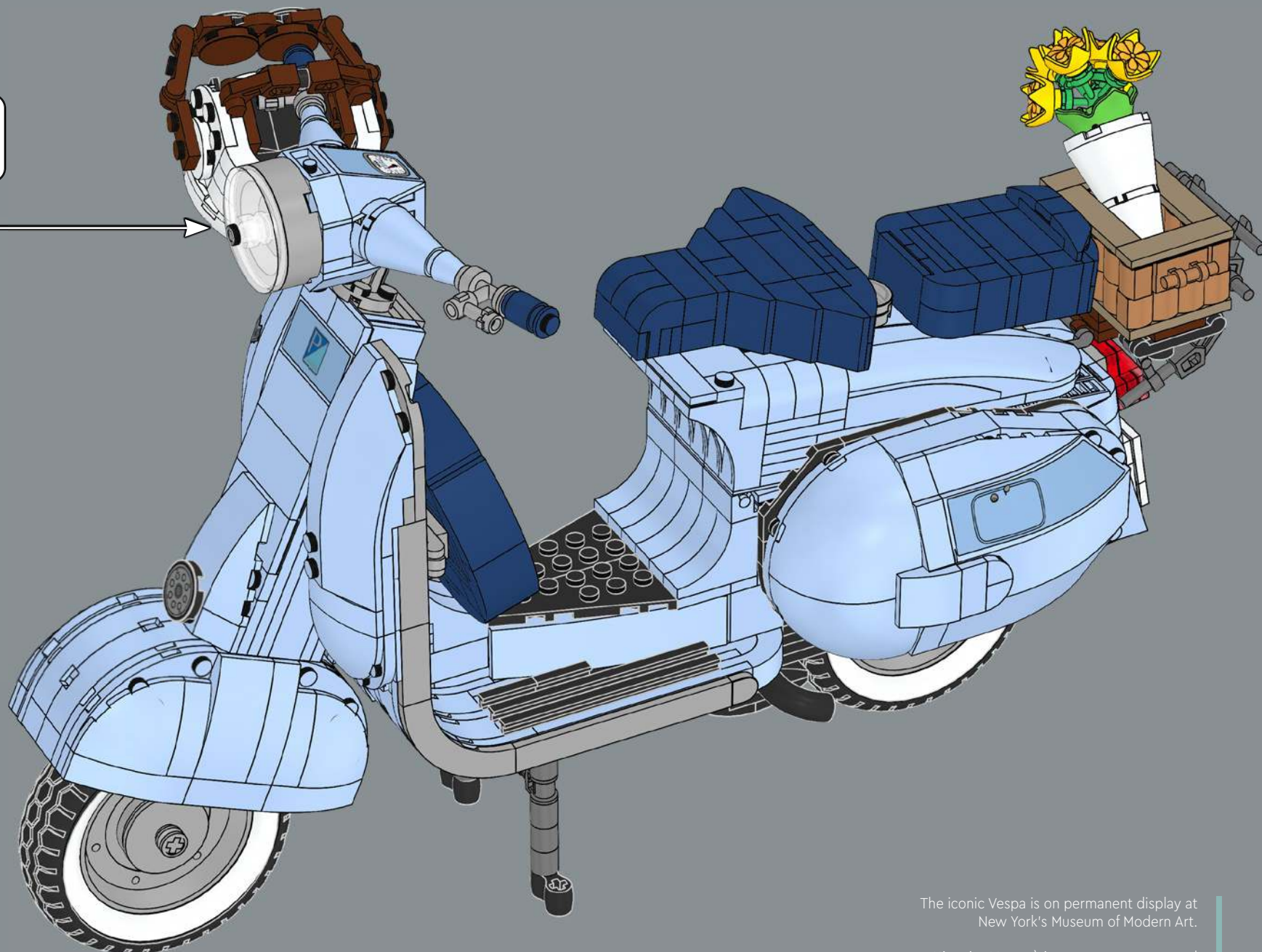

The iconic Vespa is on permanent display at
New York's Museum of Modern Art.

L'iconica Vespa è in mostra permanente al
Museum of Modern Art di New York.

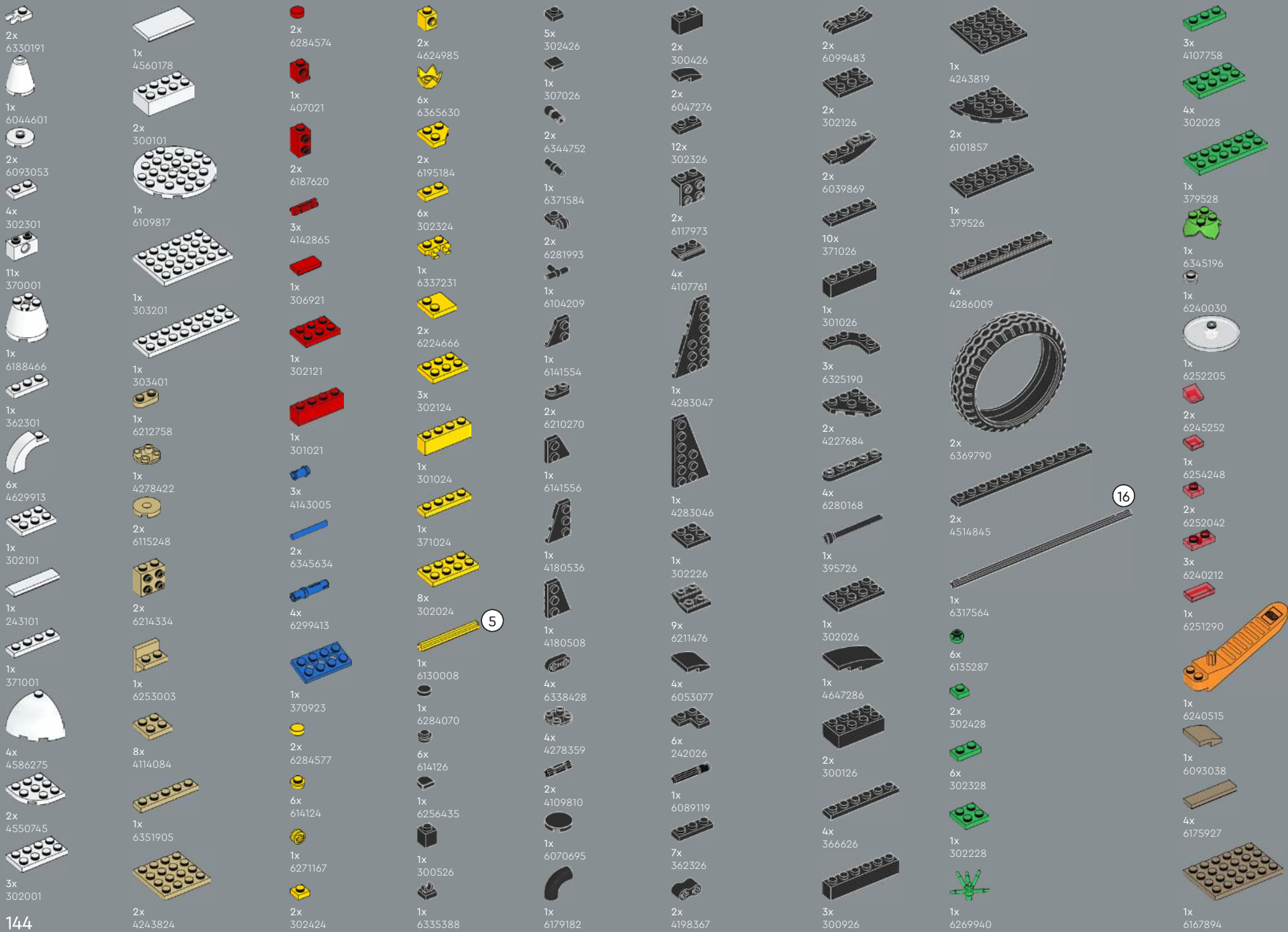

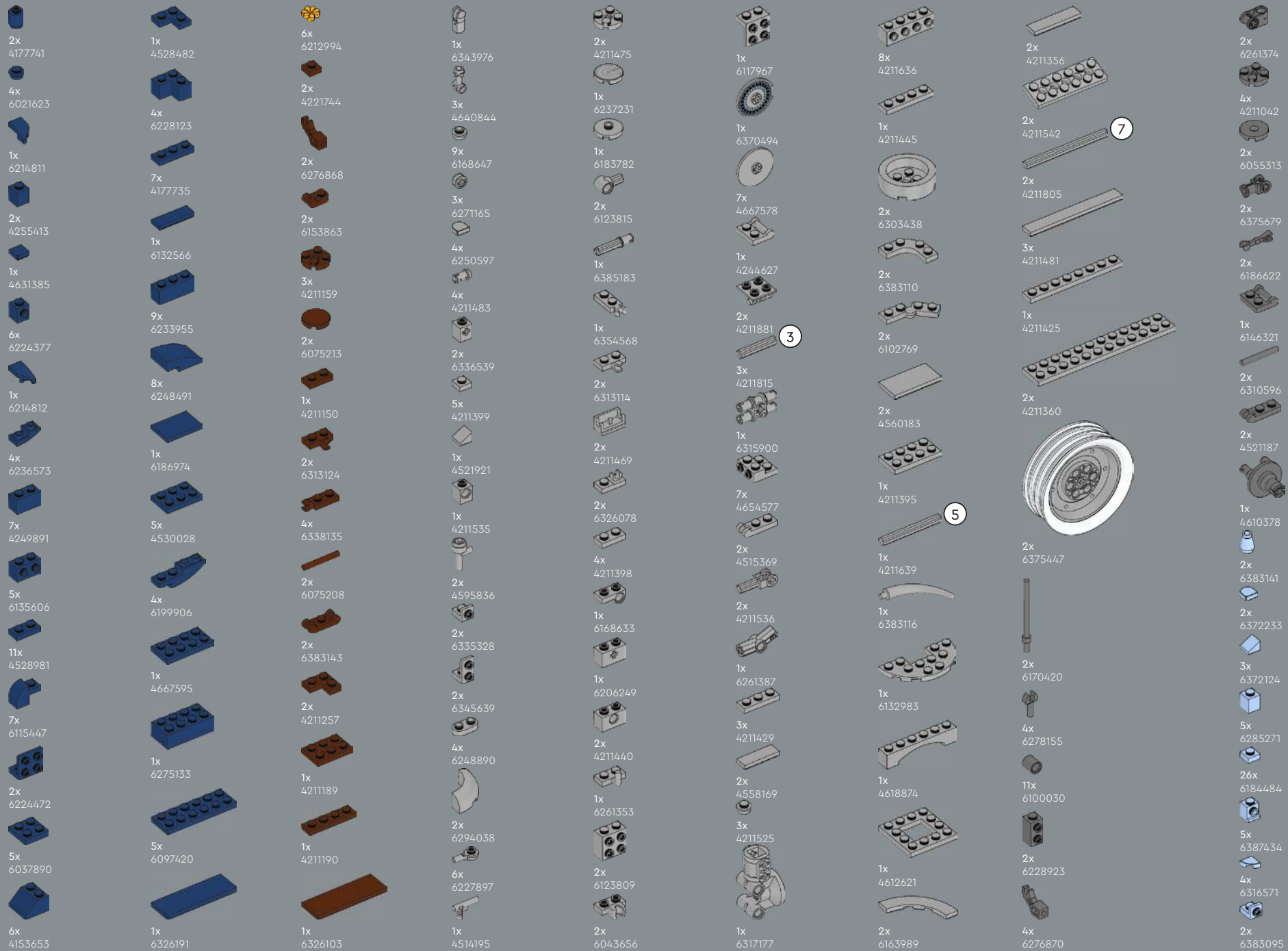

2x
6383096

1x
6383107

1x
6383109

2x
6383093

2x
6383097

2x
6383134

2x
6383139

3x
6361990

8x
6335524

22x
6372136

2x
6372146

2x
6136397

38x
6362254

3x
6383077

10x
6383082

25x
6097861

2x
6100322

4x
6057389

2x
6372232

6x
6372222

5x
6372227

2x
6162894

2x
6383104

3x
6385302

1x
6383137

2x
6136396

1x
6383073

2x
6383103

3x
6372342

2x
6372259

6x
6383113

2x
6383106

7x
6372225

14x
6372138

6x
6383112

4x
6182777

2x
6366708

6x
6387467

4x
6385731

6x
6383076

12x
6361991

9x
6058766

18x
6361988

1x
6383136

8x
6287903

4x
6383131

6x
6383105

6x
6372257

2x
6372262

2x
6132418

1x
6383133

2x
6383132

2x
6383078

5

1x
6383135

1x
6383099

4x
6271655

12x
6361985

2x
6383083

1x
6372339

8x
6383094

4x
6383102

11x
6132422

1x
6372336

10x
6383092

16x
6372125

1x
6383111

2x
6387468

2x
6383079

1x
6383115

1x
6383084

2x
6383108

1x
6383086

2x
4651231

2x
6347304

2x
6295465

6x
4651232

14x
6051507



 [LEGO.com/service](https://www.LEGO.com/service)



YOU COULD WIN



YOU COULD WIN

Your feedback will help shape the future development of this product series.

Visit:

DU KÖNNTEST GEWINNEN

Dein Feedback trägt zur Weiterentwicklung dieser Produktreihe bei.

Geh auf:

VOUS POURRIEZ GAGNER

Vos commentaires nous aideront à concevoir les futurs produits de cette gamme.

Visitez :

POTRESTI VINCERE TU

La tua opinione ci aiuterà a migliorare la creazione futura di questa linea di prodotti.

Visita:

PUEDES GANAR

Tu opinión contribuirá al futuro de esta serie de productos.

Visita:

轻松获奖

您的反馈将有助于我们在今后改进本产品系列。

请访问:

LEGO.com/productfeedback

You also have the chance to win a LEGO® set.

Terms and conditions apply.*

Außerdem hast du die Chance, ein LEGO® Set zu gewinnen.

Es gelten die Teilnahmebedingungen.*

Vous pourriez également gagner un ensemble LEGO®.

Des conditions s'appliquent.*

Hai anche la possibilità di vincere un set LEGO®.

Termini e condizioni sono applicabili.*

También tienes la oportunidad de ganar un set LEGO®.

Aplican términos y condiciones.*

您还有机会赢取乐高®套装。

条款和条件适用。*

*LEGO.com/productfeedback-terms

